

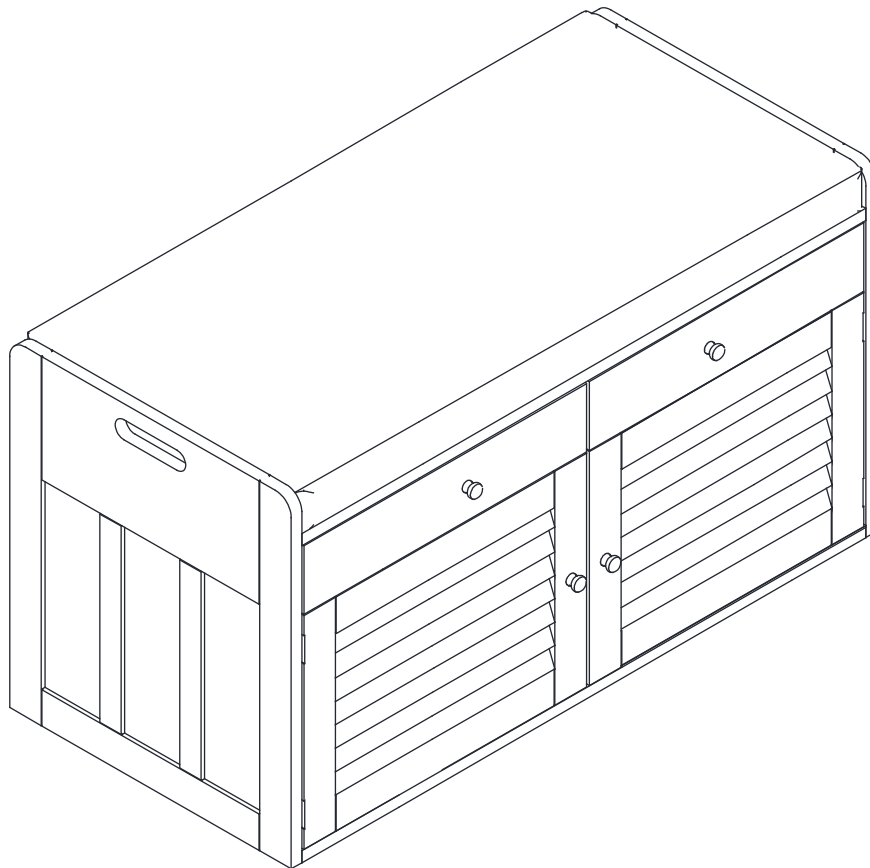

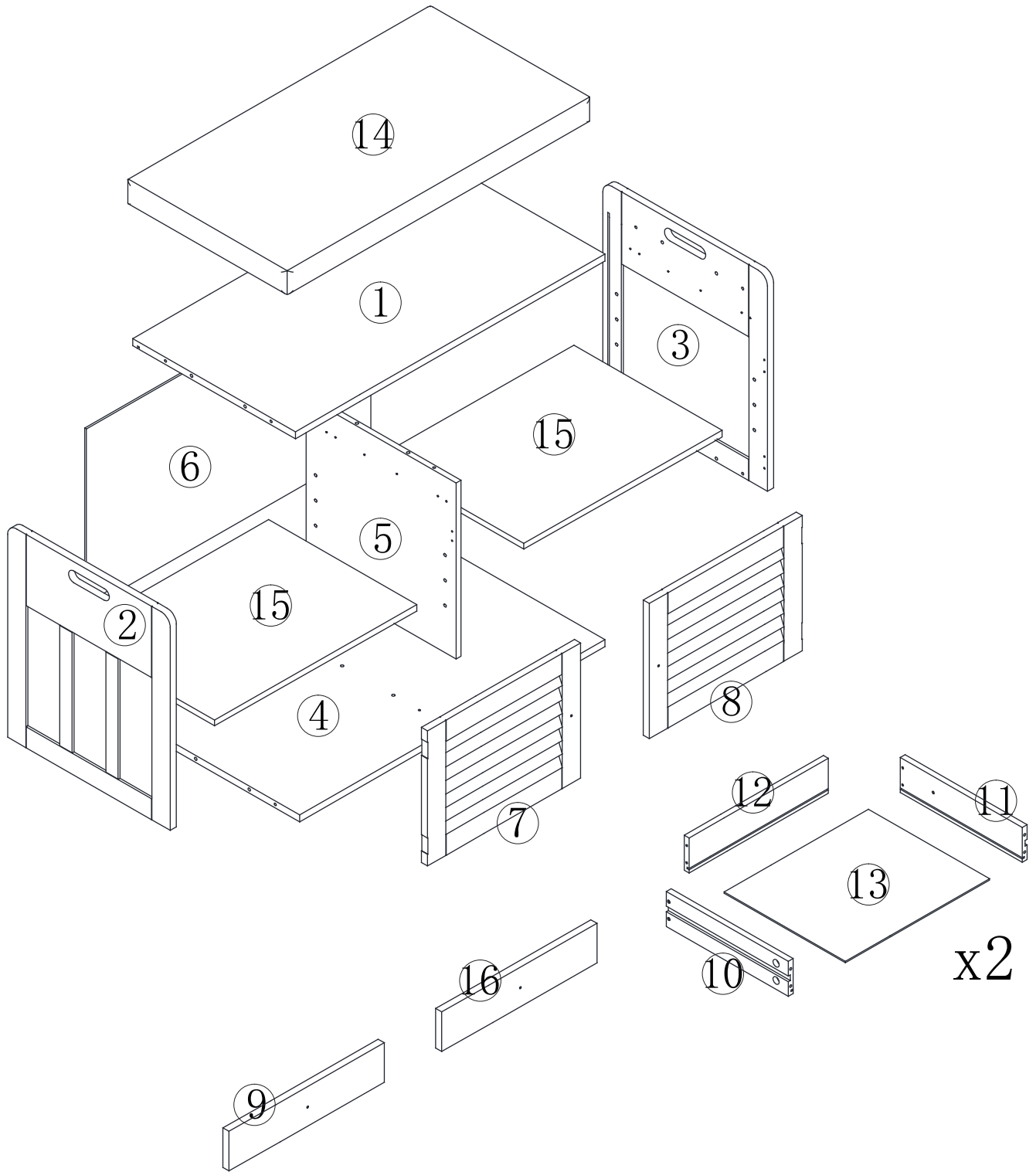



ASSEMBLY INSTRUCTIONS

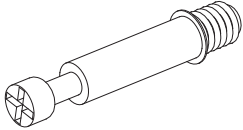
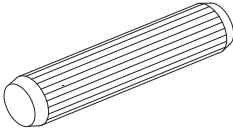
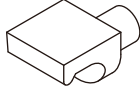
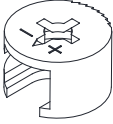
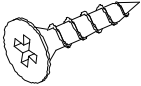

Whether the hardware or parts are lost or damaged, or any problems issue during installation, please contact us in time, we will provide you with the best after-sales service

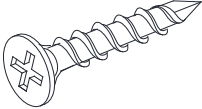
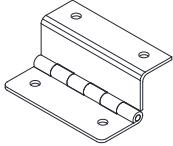
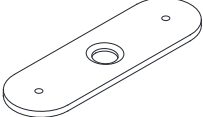

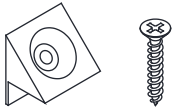
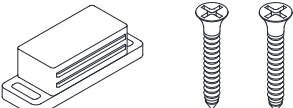
HARDWARE LIST

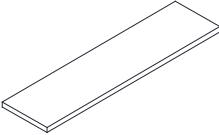
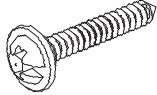
<p>A</p>  <p>$\Phi 6 \times 35 \text{mm}$ 18PCS</p>	<p>B</p>  <p>$\Phi 6 \times 30 \text{mm}$ 12PCS</p>	<p>C</p>  <p>8PCS</p>
<p>D</p>  <p>$\Phi 15 \times 9.5 \text{mm}$ 18PCS</p>	<p>E</p>  <p>$\Phi 3 \times 12 \text{mm}$ 26PCS</p>	<p>F</p>  <p>4PCS</p>
<p>G</p>  <p>$\Phi 4 \times 30 \text{mm}$ 10PCS</p>	<p>H</p>  <p>4PCS</p>	<p>I</p>  <p>2PCS</p>
<p>J</p>  <p>4SETS</p>	<p>K</p>  <p>4SETS</p>	<p>L</p>  <p>2SETS</p>
<p>M</p>  <p>4PCS</p>	<p>N</p>  <p>6PCS</p>	<p>P</p>  <p>$\Phi 2.5 \times 10 \text{mm}$ 2PCS</p>

TOOLS REQUIRED

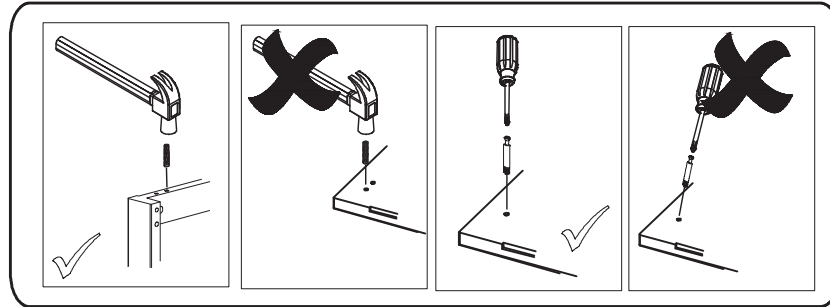
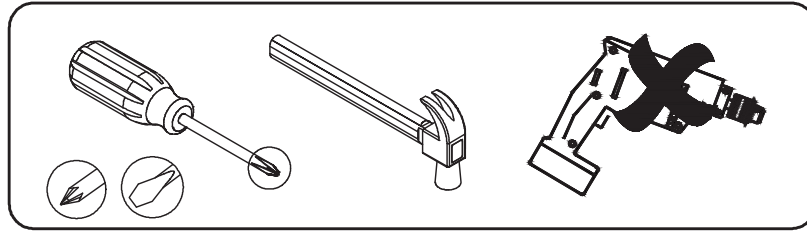

Note: Do not use tools other than those required, as this may damage your item.

IMPORTANT NOTES

Please check that you have all the hardware and screws. If you are missing any hardware or screws, please contact us.

Please be careful not to drag the boards on the floor during the installation process, causing worn.

Don't attempt to repair or modify parts that are broken or defective. Please contact the store immediately.

Do not tighten screws until all screws are in the correct position.

Do not use this product unless all bolts, screws and knobs are securely fastened.

Check that all bolts, screws and knobs are securely tightened at least once every 3 months.

WARNING

If parts are missing, broken, damaged or worn, discontinue use of the product until all repairs have been made using parts authorized by the manufacturer.

Failure to comply with these regulations may result in serious injury.

DANGER

Children must be under parental supervision when using the product.

①

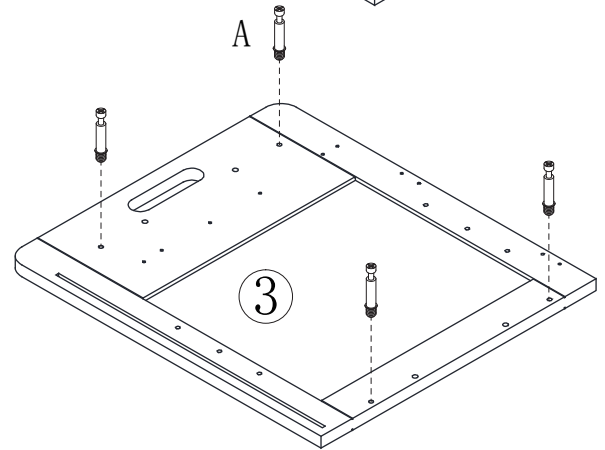
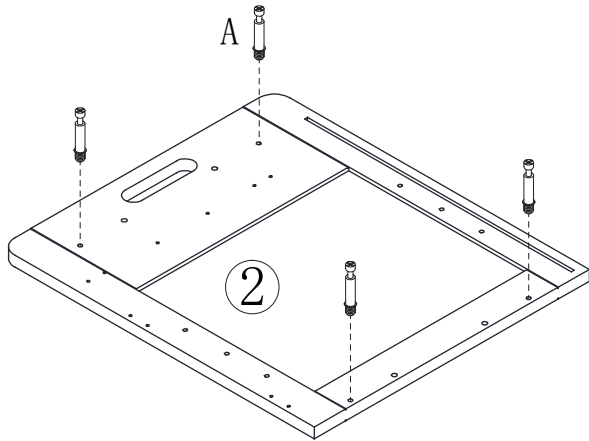
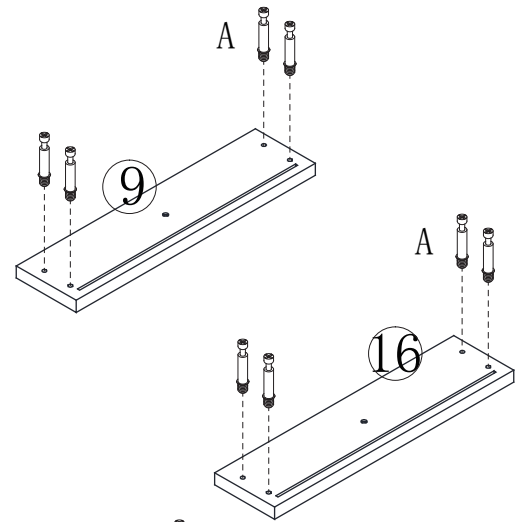
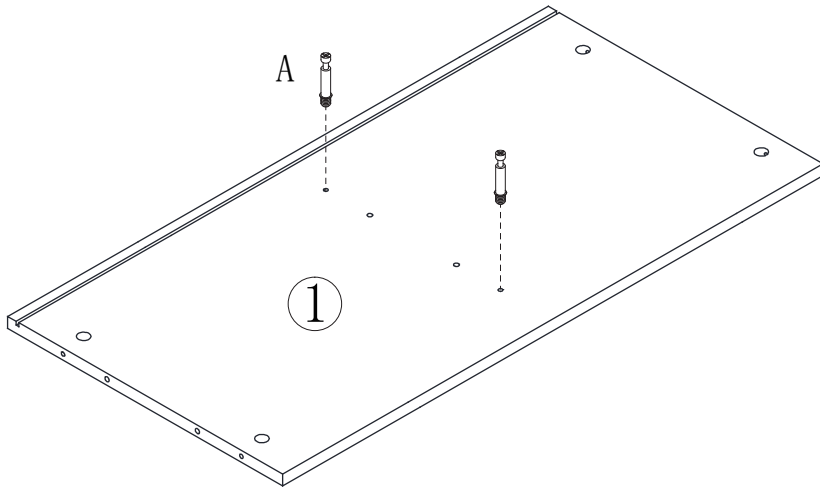



First, find the corresponding board as shown in the picture. Then screw part A into the corresponding hole.

 (A)x18pcs

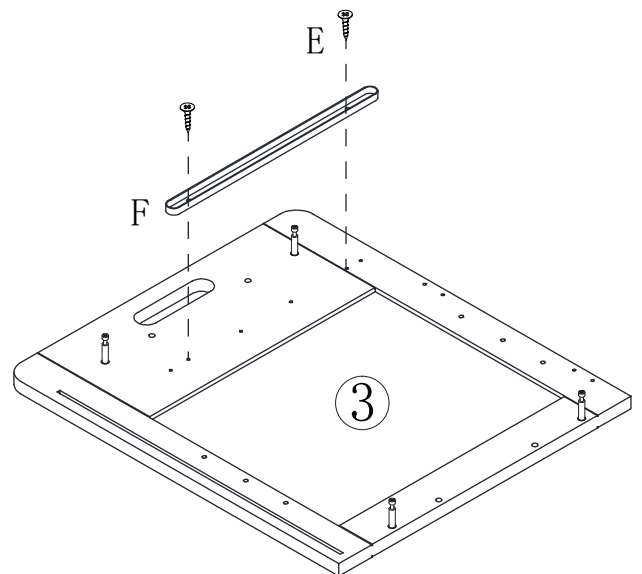
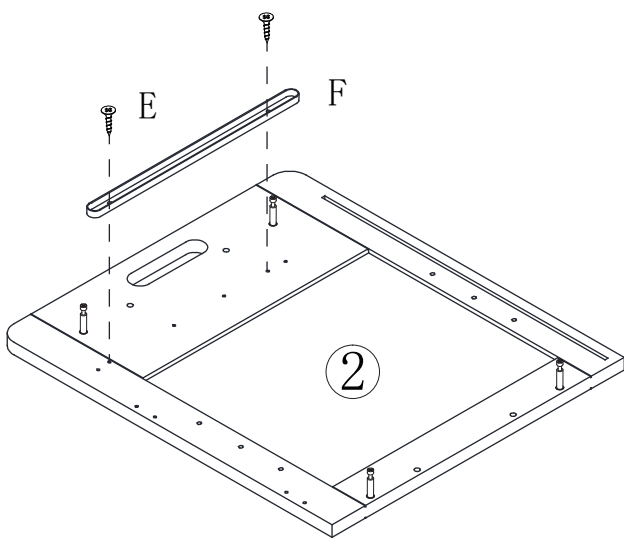
②







 (E)x4pcs
 (F)x2pcs

Please note that 2,3 boards are placed in the same position and direction as the picture.

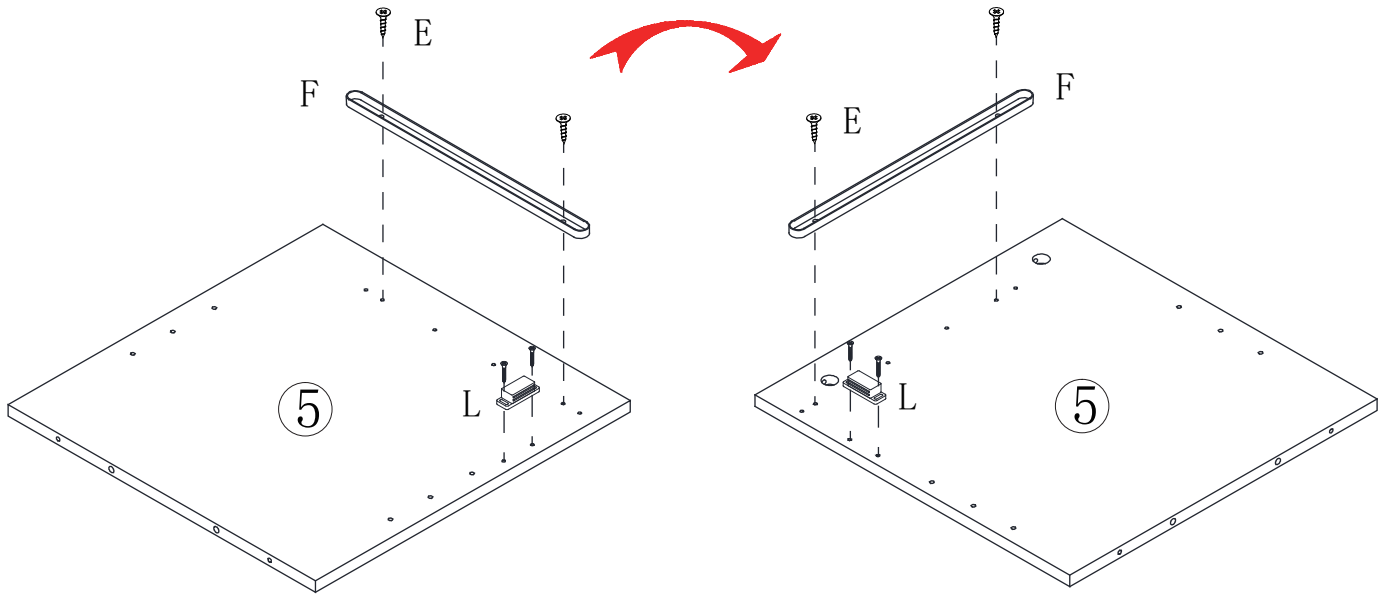
③



Turn over part 5 to install the other side

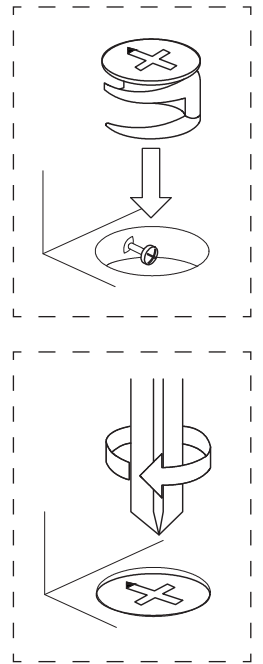
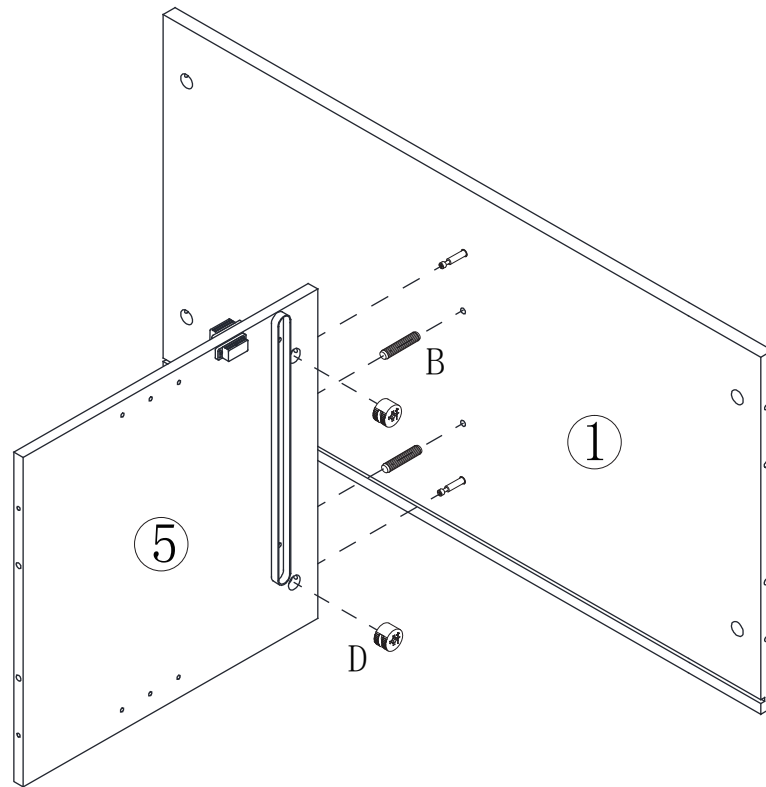
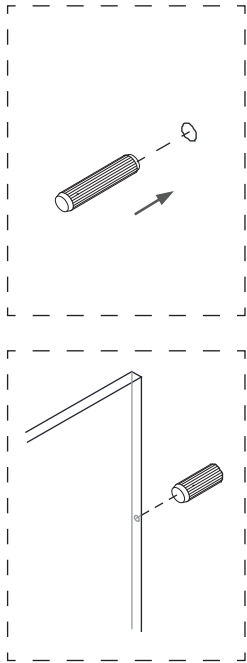

-  (E)x4pcs
-  (F)x2pcs
-  (L)x2sets

④





-  (B)x2pcs
-  (D)x2pcs

Make sure that the D part is fully inserted into the hole and the screw is clamped before locking.

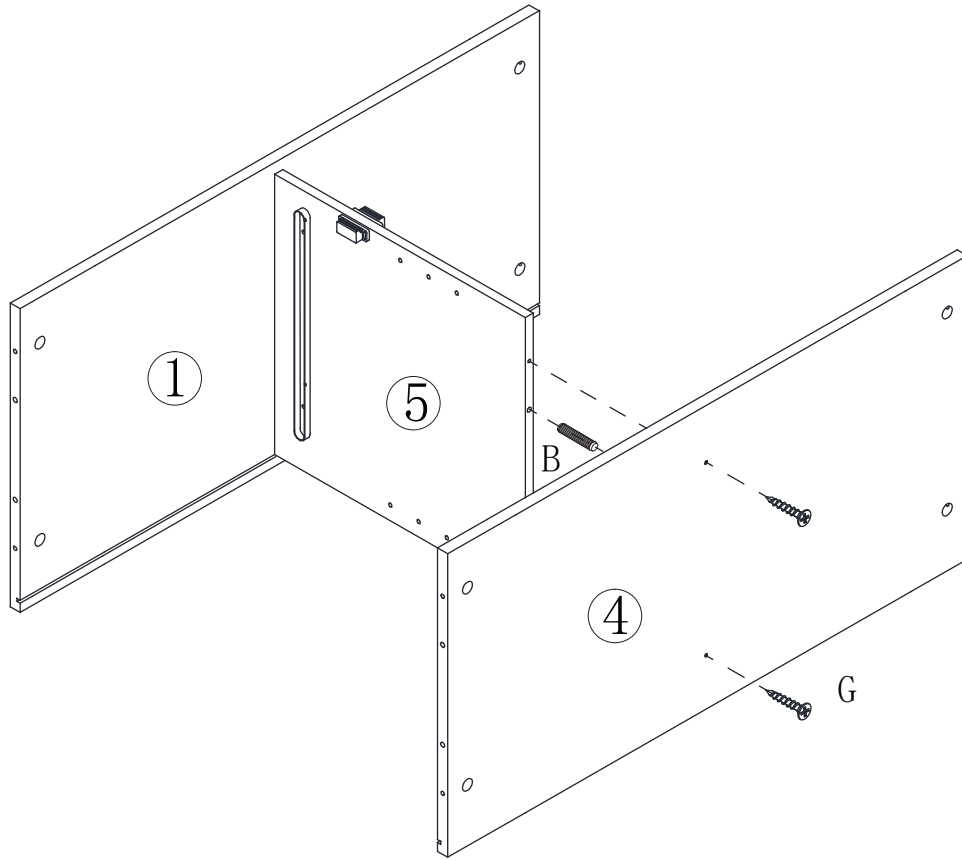
5





	(B)x2pcs
--	----------

	(G)x2pcs
--	----------

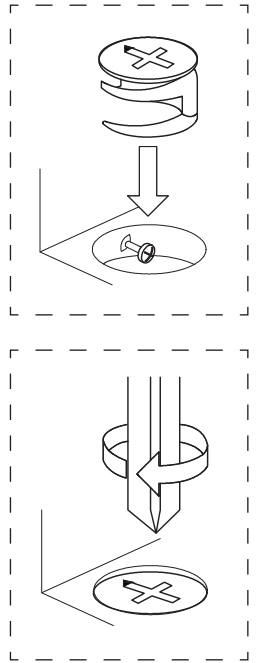
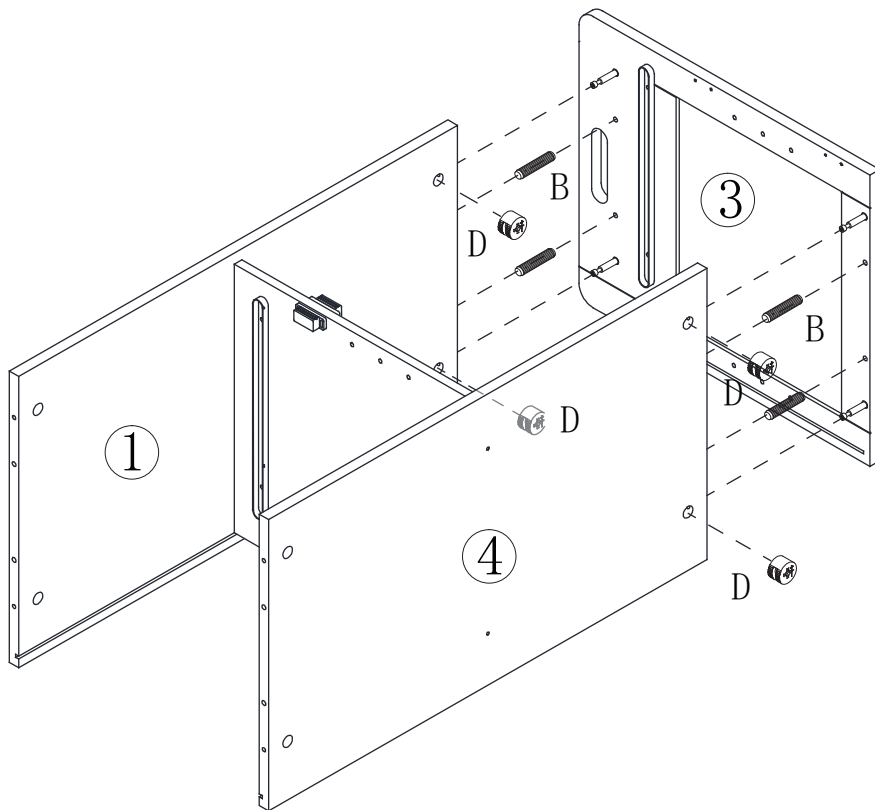
6



	(B)x4pcs
--	----------

	(D)x4pcs
--	----------

After the board is inserted, please perform the locking of parts D as shown in the picture.

7

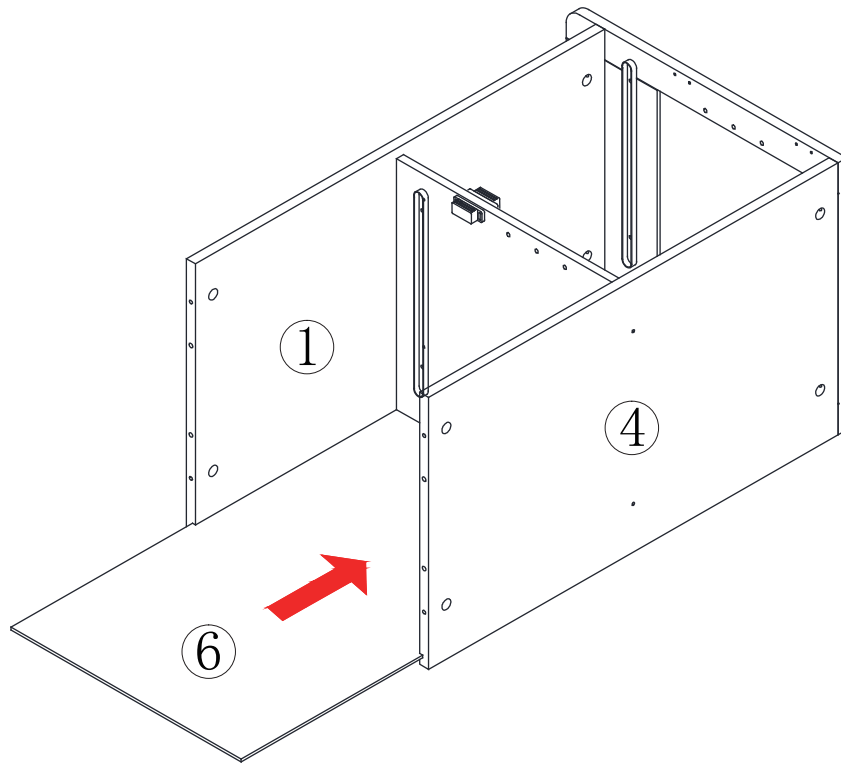

8

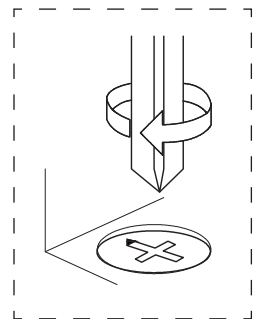
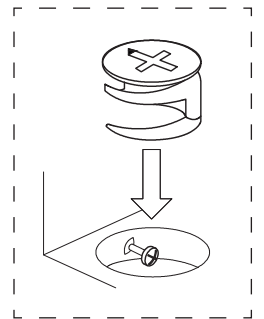
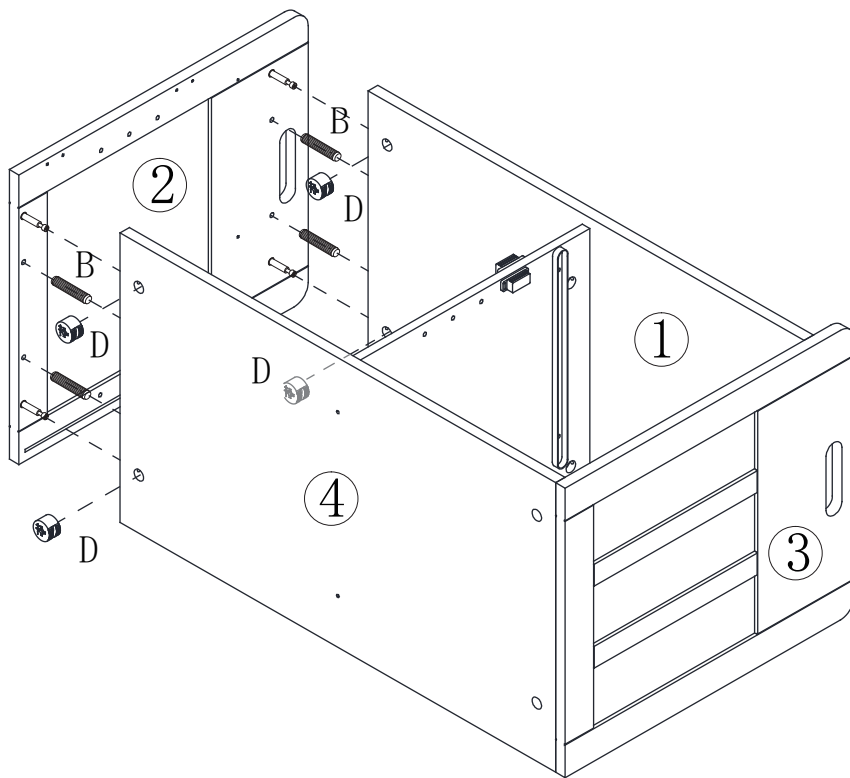



 (B)x4pcs

 (D)x4pcs

After the board is inserted, please perform the locking of parts D as shown in the picture.

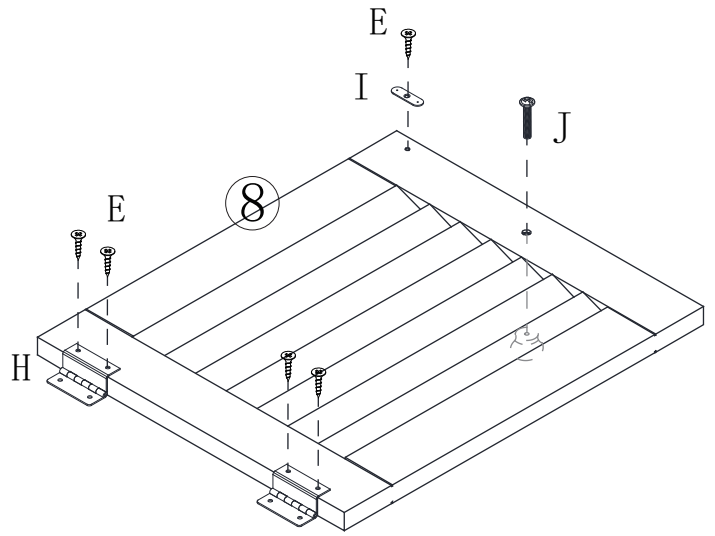
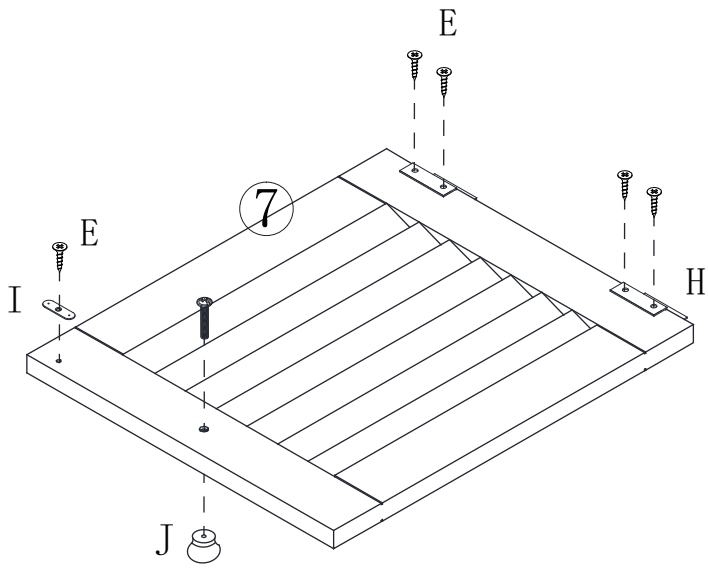
9



 (E)x10pcs

 (H)x4pcs

 (I)x2pcs

 (J)x2sets

10

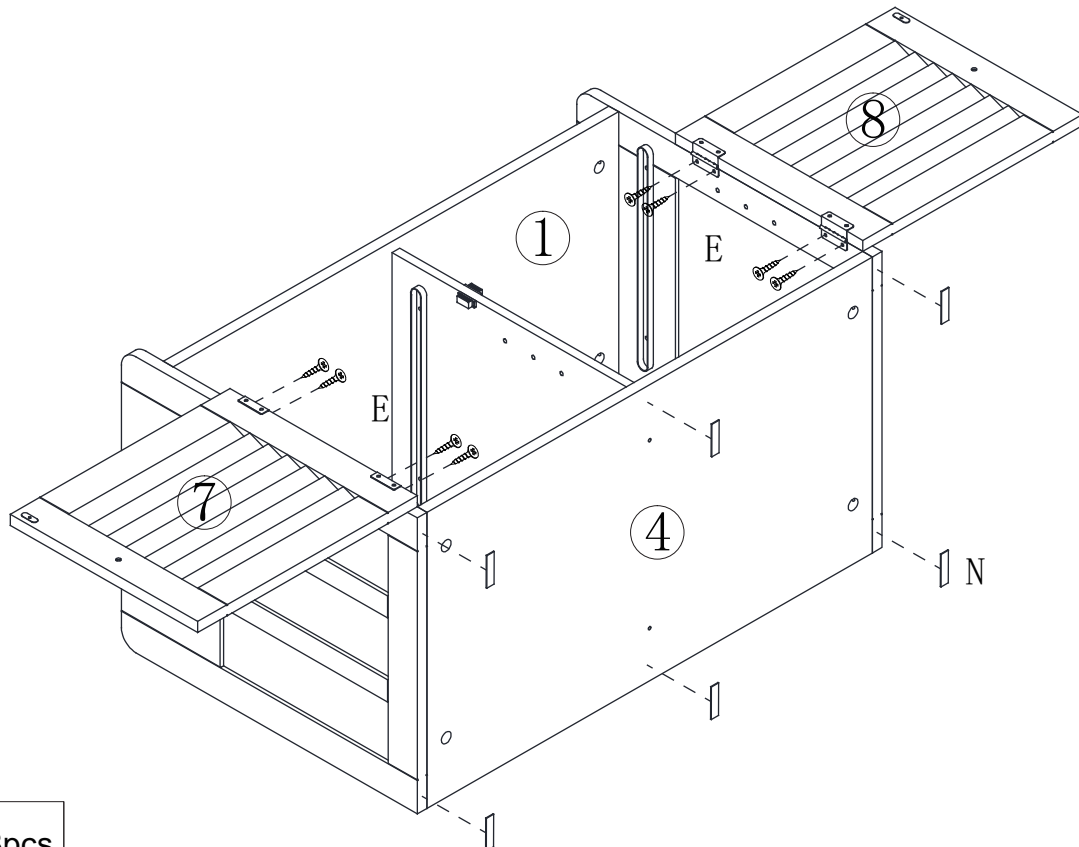



 (E)x8pcs

 (N)x6pcs

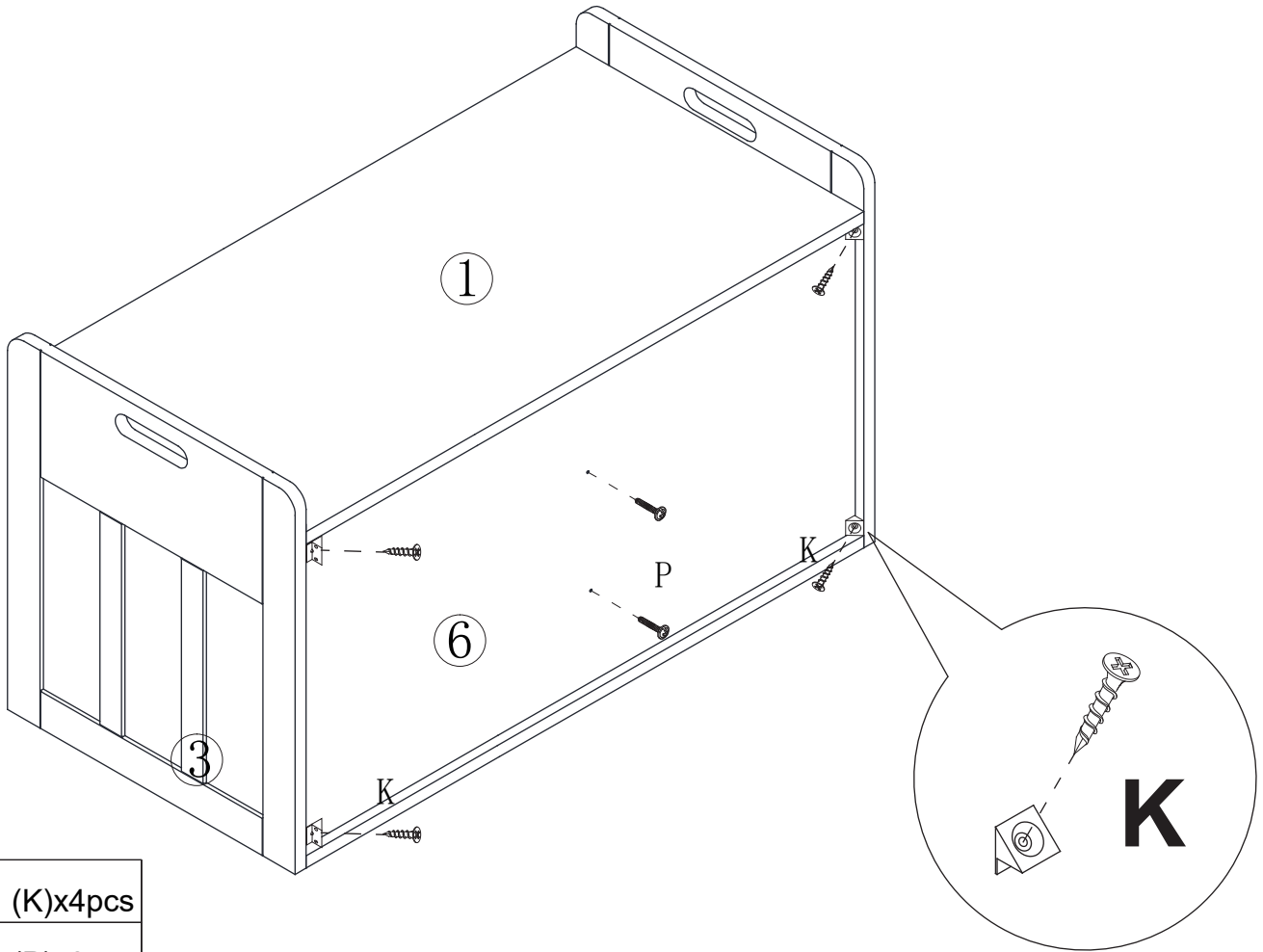
11



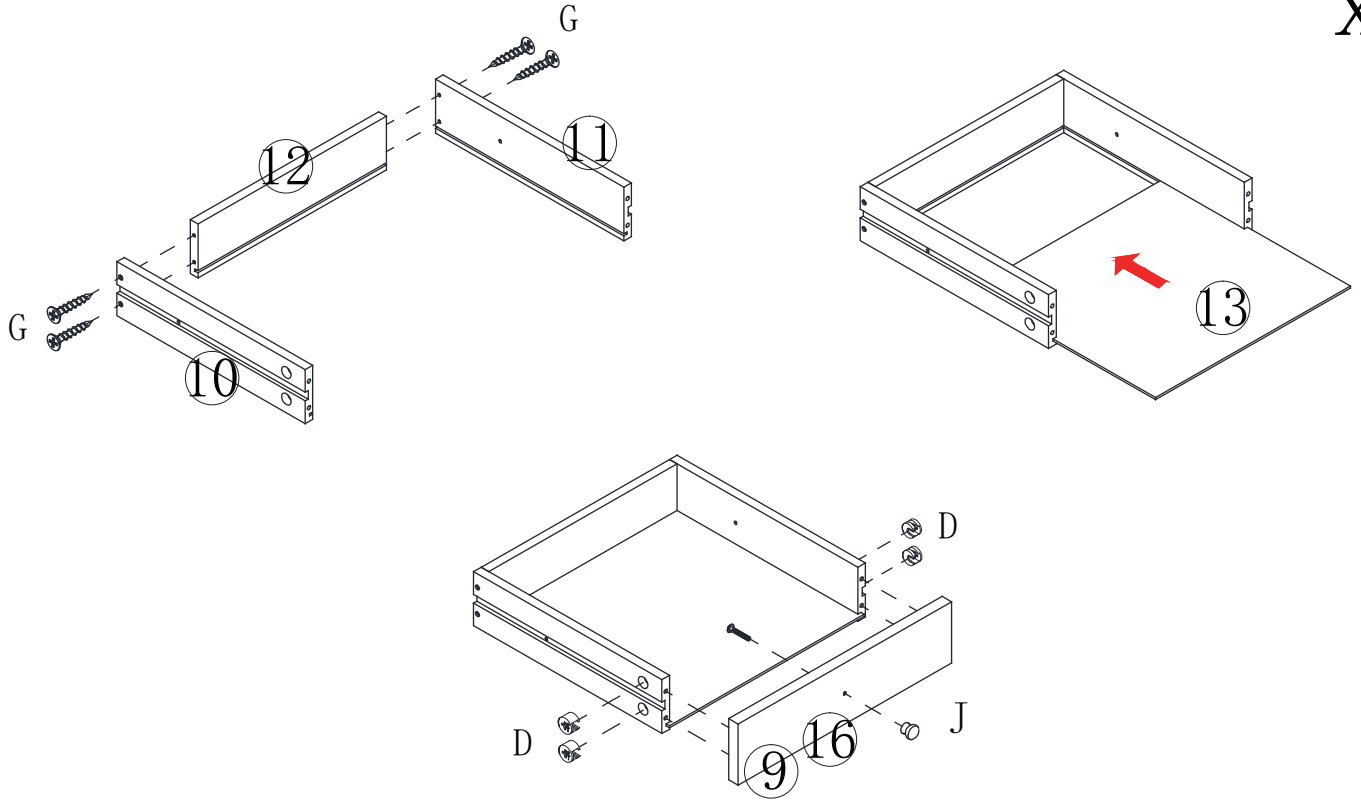

-  (K)x4pcs
-  (P)x2pcs

12



x2

-  (G)x8pcs
-  (D)x8pcs
-  (J)x2sets

Please insert the 9 wooden board holes in alignment before D screw locking.

13

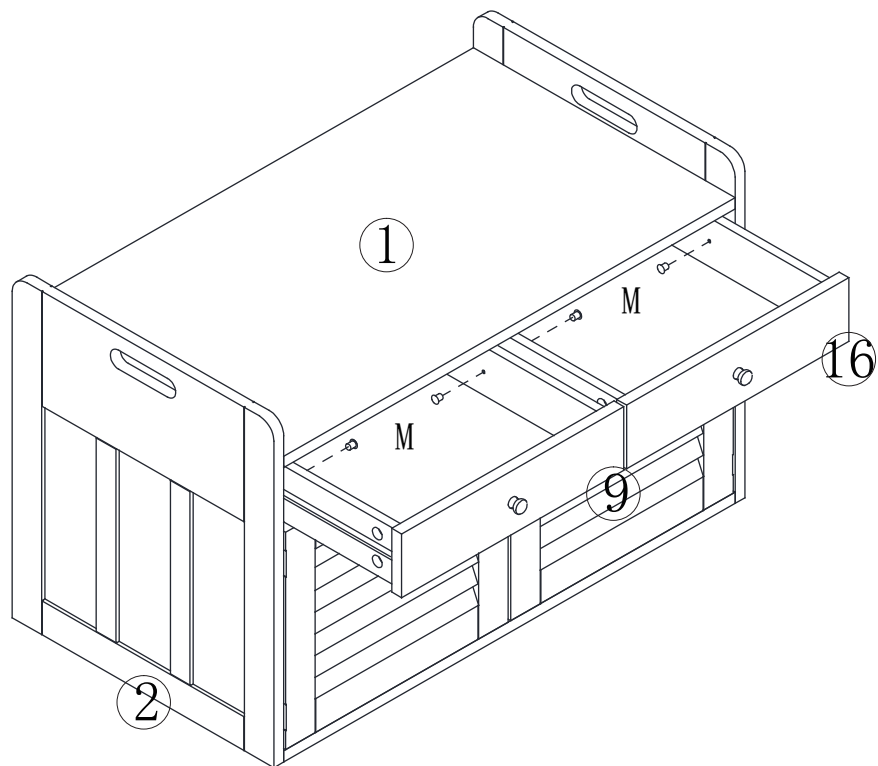

Note: This accessory is designed to prevent the drawer from being pulled completely out and falling. Please install the M Part after the drawer has been loaded into the track.



(M)x4pcs

14

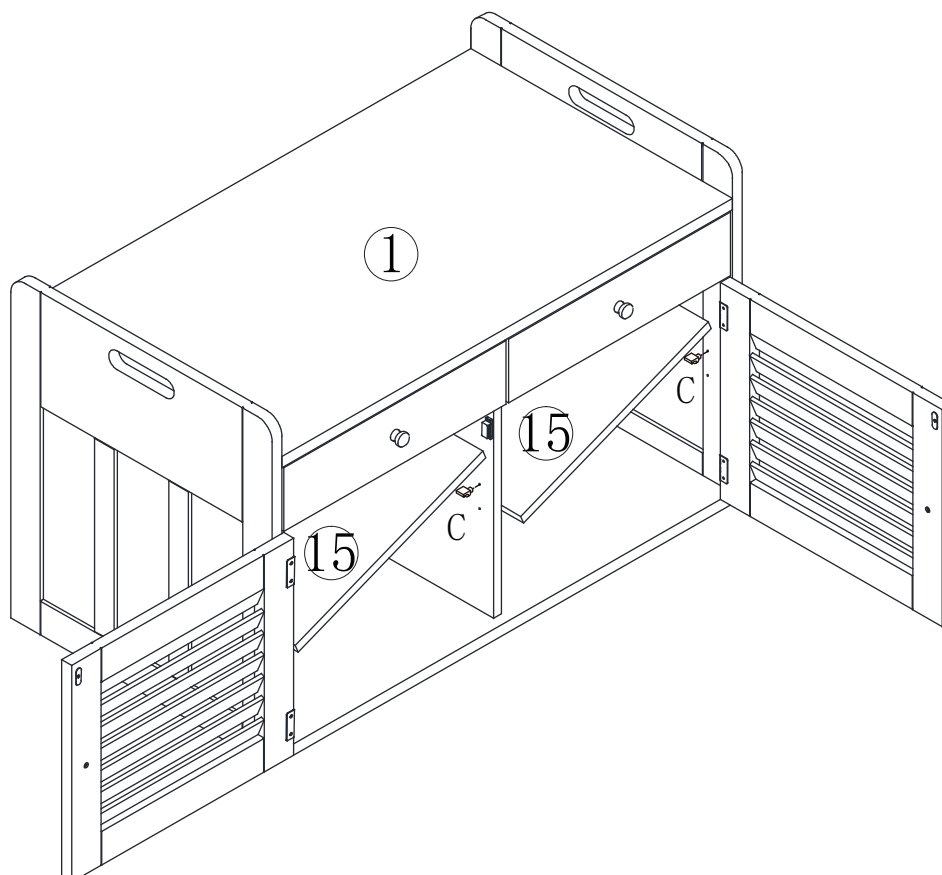

(C)x8pcs

15

