

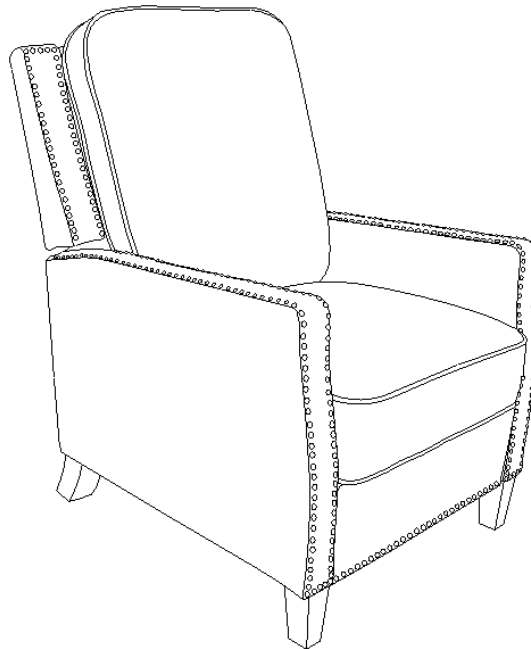





# Assembly Instructions

**Caution: You must read this before you proceed**

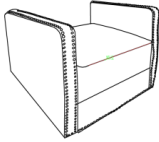
## Push Back Chair

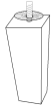

## Parts List

| Label | Picture   | Description  | QTY |
|-------|---|--|-----|
| A     |    | Chair Base   | 1   |
| B     |    | Chair Backrest                                     | 1   |
| C     |   | Left Wing  | 1   |
| D     |  | Right Wing   | 1   |
| E     |  | Front Leg (with Acrylic Gasket)                    | 2   |
| F     |  | Hind Leg (with Silicone Gasket and Acrylic Gasket) | 2   |





## Hardware

| Label | Picture   | Description    | QTY |
|-------|---|----------------|-----|
| ①     |  | Acrylic Gasket | 3   |

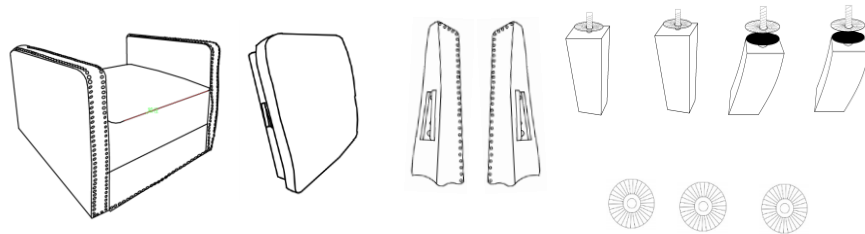
## Assembly Preparation

Before  
Beginning  
Assembly:



-  • Read instructions, cover to cover-
-  • Have 2 adults on hand for assembly-
-  • Do not assemble on flooring or carpet-
-  • Assemble on a clean non-marring surface (packing foam)-
-  • Save all packaging until finished-

## Assembly Steps

### Overview

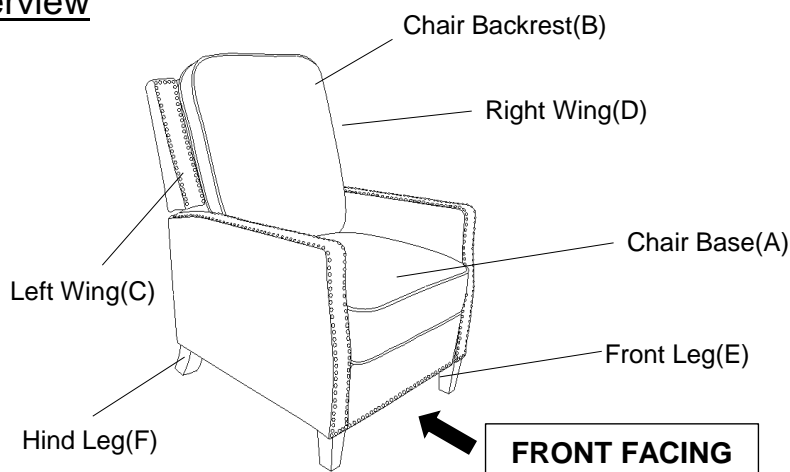

This Push Back Chair has multiple parts and may require about 30 minutes to assemble. To give you an overview of the Push Back Chair parts, the above picture is to help you put the various parts into perspective. Please read through the instructions below to familiarise yourself with the parts and steps before assembly.

**Step 1**

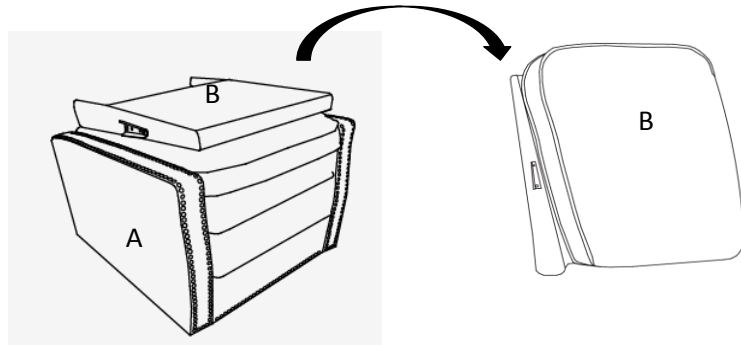

Take out the Chair Backrest(B) from Chair Base(A).  
Place the Chair Base(A) facedown on a clean, non-marring surface.

**Step 2**

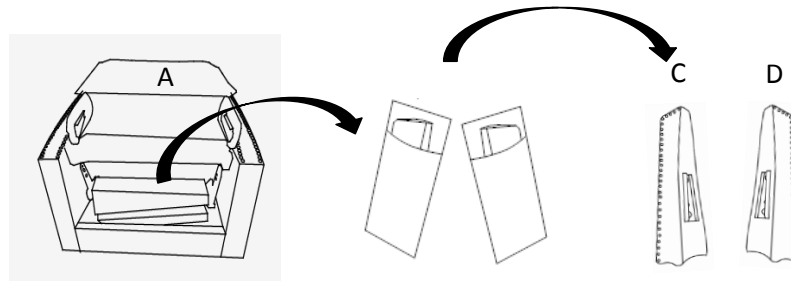

Take out both non-wovens bags from the bottom of Chair Base(A) and open them to take out the Left Wing(C) and Right Wing(D).

**Step 3**

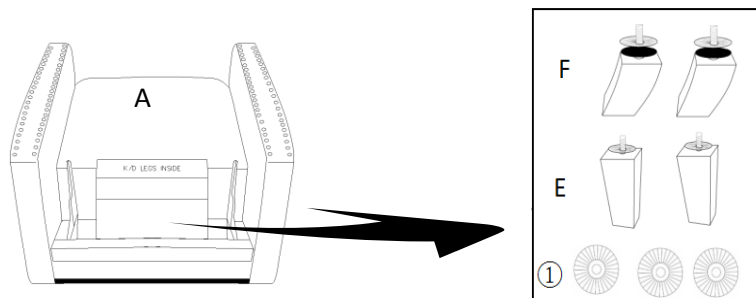

Remove the small carton and take out the Front Legs(E), Hind Legs(F) and Acrylic Gaskets(①).

**Step 4**

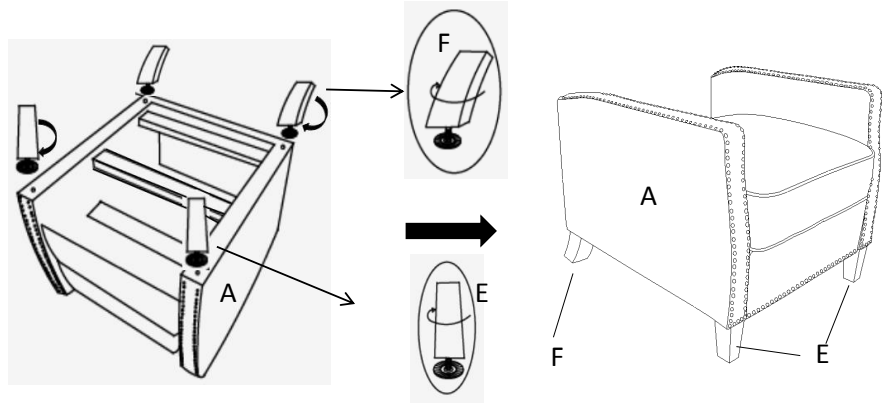

Install the Front Legs(E) and Hind Legs(F) to Chair Base(A) by inserting the threaded stems into the mounting positions at the corners of the Chair Base(A).

Tighten by turning the Legs clockwise.

Take care of the shape of the Legs and ensure they in the correct positions.

**Note: The use of Gaskets are OPTIONAL and are especially useful to help alleviate slight wobbleness. Some Legs may need more than one gasket whilst some Legs may not need any.**

**Step 5**

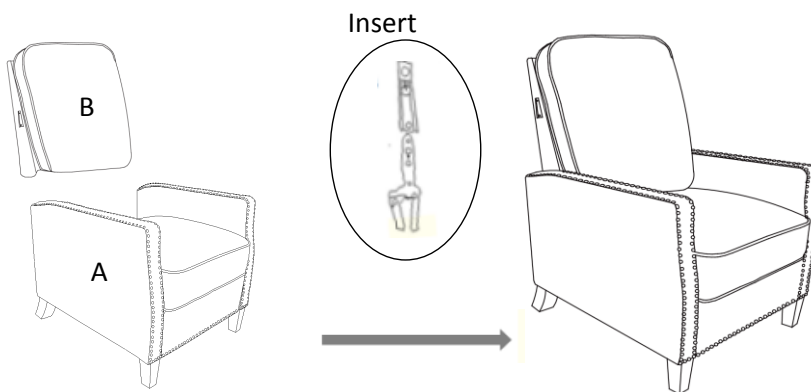

With assistance from your adult partner, hold up the Chair Backrest(B) and stand behind the Chair Base(A).  
 Insert the small metal arms on the sides of the Chair Backrest(B) into the prefabricated slide lock gadget on the Chair Base(A) as shown above.  
 Firmly but gently, push the Chair Backrest(B) downwards until the Chair Backrest(B) is fully slotted and locked into position.

**Step 6**

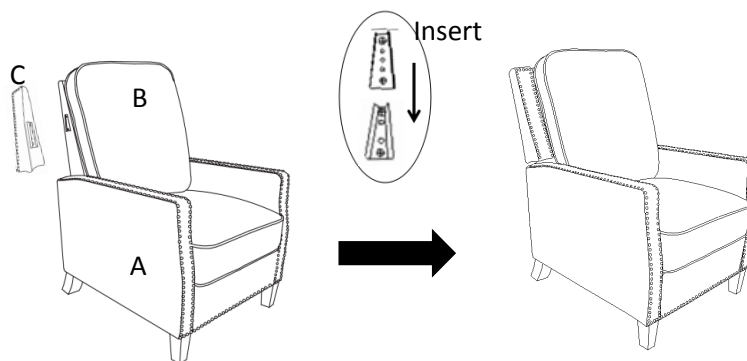

Align the mounting brackets of the Left Wing(C) with those on the left side of Chair Backrest(B).  
 Then slide Left Wing(C) downward by hand to make sure it locks into position as shown in the picture.

**Step 7**

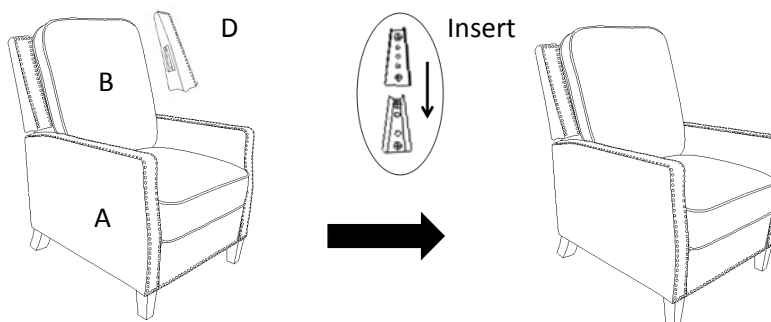

Align the mounting brackets of the Right Wing(D) with those on the left side of Chair Backrest(B).  
 Then slide Right Wing(D) downward by hand to make sure it locks into position as shown in the picture.

**Step 8**

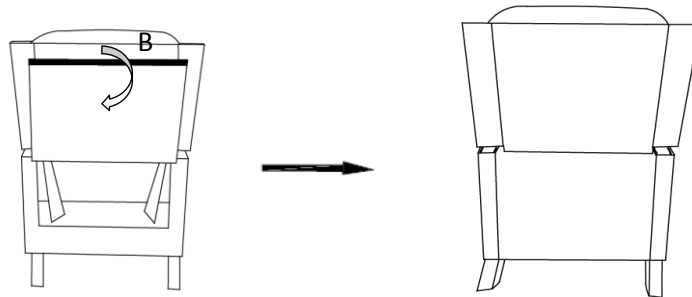

Smooth down the fabric flap on the Chair Backrest(B).  
Run your hands down both sides of the flap, from top to bottom, allowing the velcro tape to adhere to the flap under the seat of the chair.

**Step 9**

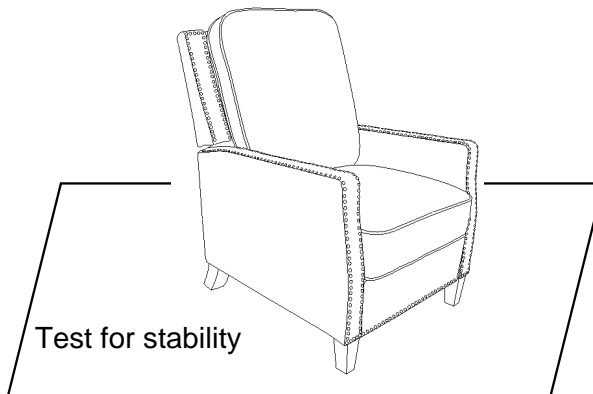

Make sure all parts are connected and securely locked into position.  
Your Push Back Chair is ready for use.  
**This Push Back Chair can only be used on a flat, level surface.**

## Disassembly Instructions

### Step 9

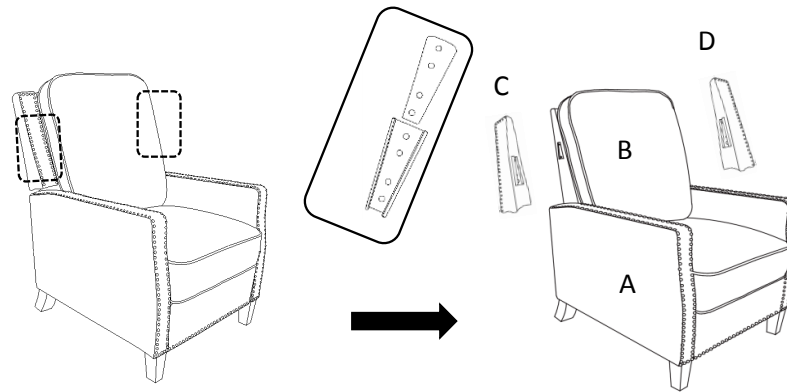

Push up on the Right Wing(D) and Left Wing(C) one by one until they are removed from the Chair Backrest(B).

### Step 10

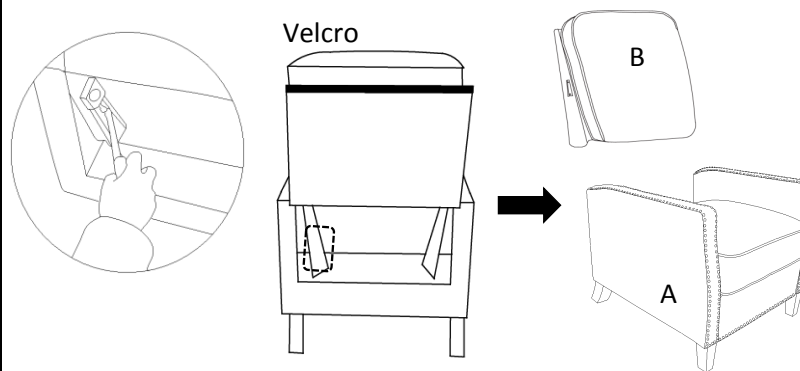

### **To Disassemble Push Back Chair:**

Open the flap on the Backrest(B), use a screwdriver (Don't use your fingers) pressing outward on the metal ear on the preattached Metal Bracket on one side of the Chair Base(A).

With assistance of your adult partner to keep the Chair Base(A) in place, pull the Backrest(B) upward at the same time, repeat the same step for another side.

## **Warning**

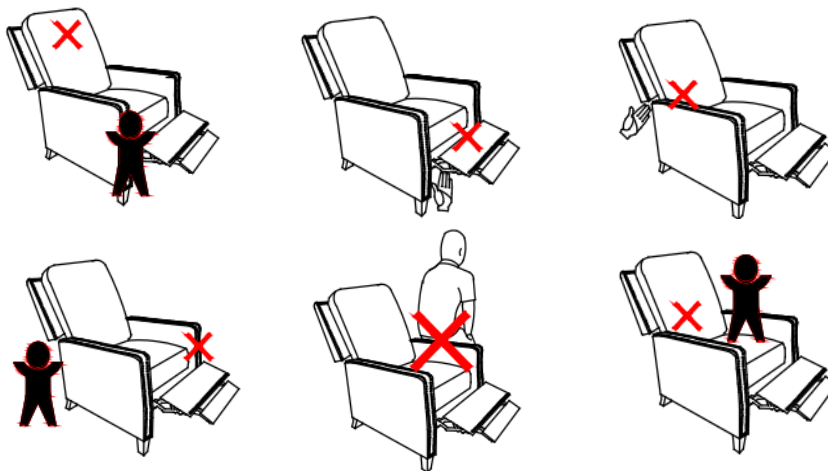

Do not allow children to play on the Push Back Chair.

Always leave the Push Back Chair in an upright and closed position after use.

Keep hands and feet clear of the footrest mechanism and any gaps.

Don't sit on the armrests of Push Back Chair.

## User Instructions

### Push Back Chair

Please read the Instruction Manual below carefully before use.

This is a Push Back Chair. At anytime in a reclined seat position or in the upright position. You may enjoy the rocking motion by using your body weight in a back-front rocking motion.

Supervise children, when they use the Push Back Chair.

#### To get into the Recline position:

Sit into the seat.

Use your body weight and push backwards into the seat into a fully reclined position.



#### To move the Chair back into the Upright Position:

Tilt your body weight slightly forward and upwards.

The seat back will come up to an upright position.







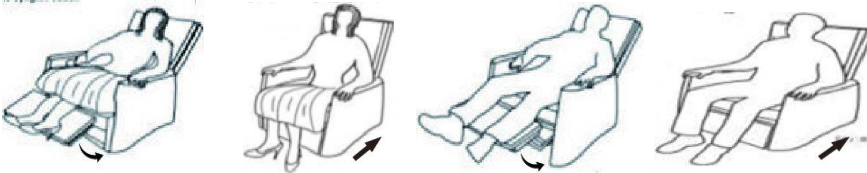













Use your feet to push the Footrest down.

The Chair will automatically lock when it is in the fully upright position.

Where necessary, use your arms help lift/push yourself out of the seat



## Care & Maintenance

-   ● Do not put hot items directly on furniture surface
  -   ● Do not clean furniture with harsh cleansers or polish.
  -   ● Do not place furniture under direct sunlight.
  -   ● Do not place furniture near heating or cooling vents.
  -   ● Do not write on furniture without a padded barrier to protect the surface.
  -   ● Do not place furniture outside . For indoor use only .
  -   ● Not for commercial use. For residential use only .
  -   ● Stains may be removed with mild soap solution and damp cloth.
  -   ● Children should not climb or jump on the furniture.
- 
-   ● Dust and pick-up spills using a clean, non-colored, lint-free cloth .

### Questions & Answers about Proposition 65

#### • What is Proposition 65?

Proposition 65 requires businesses to provide warnings to Californians about significant exposures to chemicals that cause cancer, birth defects or other reproductive harm. These chemicals can be in the products that Californians purchase, in their homes or workplaces, or that are released into the environment. By requiring that this information be provided, Proposition 65 enables Californians to make informed decisions about their exposures to these chemicals.

Proposition 65 also prohibits California businesses from knowingly discharging significant amounts of listed chemicals into sources of drinking water.

Proposition 65 requires California to publish a list of chemicals known to cause cancer, birth defects or other reproductive harm. This list, which must be updated at least once a year, has grown to include approximately 900 chemicals since it was first published in 1987.

#### • What types of chemicals are on the Proposition 65 list?

The list contains a wide range of naturally occurring and synthetic chemicals that include additives or ingredients in pesticides, common household products, food, drugs, dyes, or solvents. Listed chemicals may also be used in manufacturing and construction, or they may be byproducts of chemical processes, such as motor vehicle exhaust.

#### • What does a warning mean?

If a warning is placed on a product label or posted or distributed at a workplace, a business, or in rental housing, the business issuing the warning is aware or believes that it is exposing individuals to one or more listed chemicals.

By law, a warning must be given for listed chemicals unless the exposure is low enough to pose no significant risk of cancer or is significantly below levels observed to cause birth defects or other reproductive harm.

#### • Where can I get more information on Proposition 65?

If you have specific questions on the administration or implementation of Proposition 65, you can contact OEHHA's Proposition 65 program at [P65.Questions@oehha.ca.gov](mailto:P65.Questions@oehha.ca.gov), or by phone at (916) 445-6900.