

# ASSEMBLY INSTRUCTIONS

ASSEMBLY  
REQUIREMENTS:

2-Person  
Assembly

Assembly Time  
Per Chair  
(Approximate)

30 Minutes

Tools Required:  
(Not Provided)

Mallet

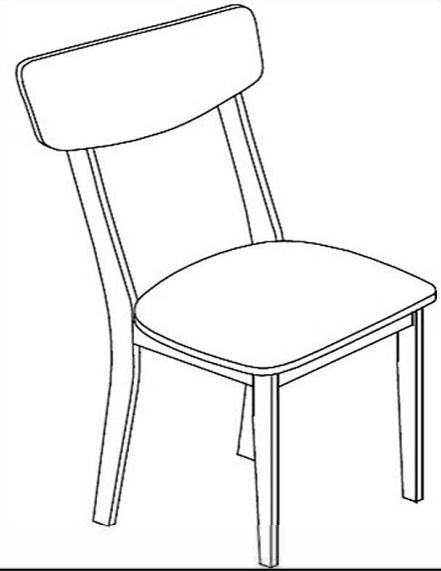

## ASSEMBLY PREPARATION

1. Remove all packaging materials, staples and packing straps from the carton.
2. Refer to Parts List and Hardware List, and ensure parts and hardware are complete before assembly.  
Contact customer service for missing parts.
3. Place all wooden parts on a clean, flat and soft surface ( e.g. carpet or rug) to prevent parts from getting scratched.

## SAFETY PRECAUTION:

1. KEEP ALL HARDWARE PARTS OUT OF REACH OF CHILDREN.
2. DISPOSE PLASTIC PACKAGING MATERIAL IMMEDIATELY TO AVOID ANY RISK OF SUFFOCATION TO CHILDREN AND ANIMALS.

## TIPS FOR ASSEMBLY:

1. Allow ample room for assembly and in close proximity to where product will be placed.
2. Assemble the product on a surface that does not scratch or damage the exterior gloss and finish of the furniture.
3. Check all of the parts and quantities are included before assembly.
4. Identify all of the parts, hardware and quantities required for each step.
5. During assembly, do not over-tighten any fittings as this may cause damage.
6. DO NOT USE POWER TOOLS TO ASSEMBLE THIS PRODUCT.
7. Always place the product on a flat, level surface.
8. Do not sit or stand on the partially assembled product; only use the product for which it is intended.

## CARE AND MAINTENANCE

- Use a slightly damp cloth to clean the product. Do not use bleach or abrasive cleaning material.
- Check all the fittings periodically and re-tighten as necessary. Do not use the product if any of the parts is damaged or broken.
- Never allow any kind of liquid to remain on your furniture. Absorption can cause wood to warp or delaminate.
- Do not place hot items (e.g. hot drinks) directly onto the wood surface.
- Do not drag and/or pull the furniture.









This product is for indoor and household use only - not for commercial use.

# ASSEMBLY INSTRUCTIONS

## PARTS LIST (FOR 4 CHAIRS)

NO	COMPONENT	QTY
P1	BACK REST	4
P2	FRONT RAIL Labeled "A"	4
P3	BACK RAIL Labeled "B"	4
P4	LEG FRAME	8
P5	CHAIR SEAT	4

## HARDWARE LIST (FOR 4 CHAIRS)

NO	DESCRIPTION	QTY	Extra
A	JCBC BOLT M6 x 40mm 	16PCS	1PC
B	SPRING WASHER 	16PCS	1PC
C	CSK SCREW M3.5 x 16mm 	24PCS	1PC
D	'L' BRACKET 	12PCS	1PC
E	ALLEN KEY M4 	1PC	
F	WOOD DOWEL 	32PCS	1PC
G	JCBC BOLT M6 x 25mm 	16PCS	1PC
H	WOODEN BUTTON 	16PCS	1PC
I	LEG STUD 	16PCS	1PC

### STEP 1

Identify the 2 drilled hole and slot for screw on both ends of Front Rail (P2) and Back Rail (P3). Next, Insert Wood Dowel (F) into the 2 drilled hole and attach (P2) and (P3) to Leg Frame (P4) as shown. (Note : the arrow points up on each part). Use Allen Key (E) to drive JCBC Bolt (A) fitted with Spring Washer (B) to fasten (P2) to (P3). Do not tighten (A) completely at this time.

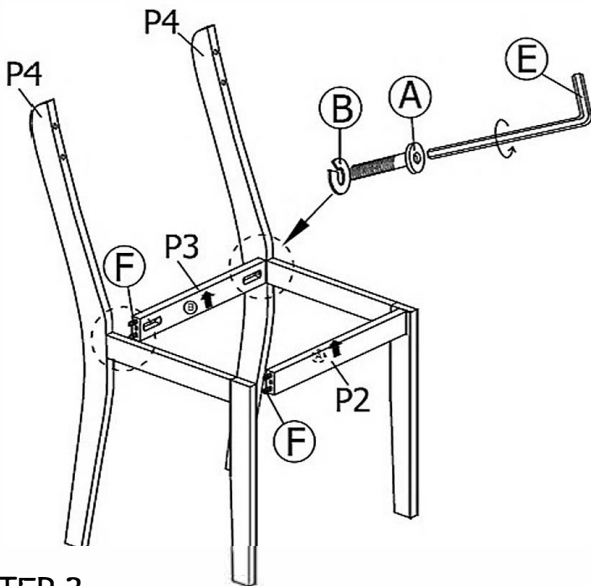

### STEP 2

Use Allen Key to drive Bolt (G) to fasten Back Rest (P1) to (P4). Do not tighten (G) completely until all 4 bolts are in place. Insert Wooden Button (H) to conceal (G). Tighten JCBC Bolt (A) in STEP 1 completely. Do not over-tighten.

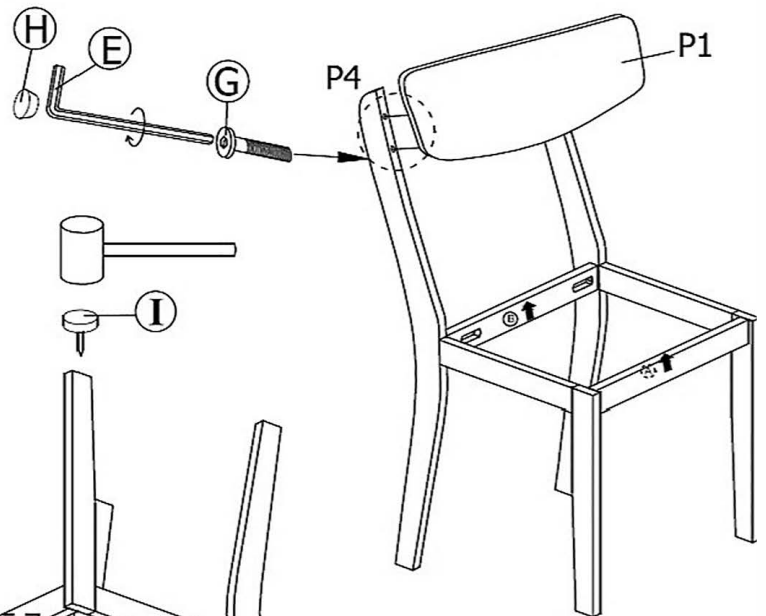

### STEP 3

Place the Chair Seat (P5) bottom-side up on an elevated surface (e.g. table top). Center the seat frame to (P5) with the rear of the seat against the Chair Back. Use 'L' Bracket (D) and Screw (C) to fasten (P5) to the seat frame. Gently nail Leg Stud (I) into each end of the leg. Place the chair right-side up.

The assembly of the chair is complete.

