

ASSEMBLY INSTRUCTION DINING BENCH







IMPORTANT SAFETY CONSTRUCTION

Thank you for purchasing this quality product. Be sure to check all packing material carefully for small parts that may have come loose inside the carton during shipment. Please read all instruction carefully before assembling. For your safety, assembly by two people is recommended.

PARTS INCLUDED:

- (1) Bench Seat (a)
- (4) Bench Legs (b)
- (2) Long Stretchers (c)
- (2) Short Stretchers (d)

HARDWARE ENCLOSED:

- A 8x  Ø8
- B 4x  Ø6.3 x 40mm
- C 12x  Ø8 x 13mm
- D 12x  Ø8 x 16mm
- E 1x 
- F 1x 
- G 4x  Ø4 x 38mm

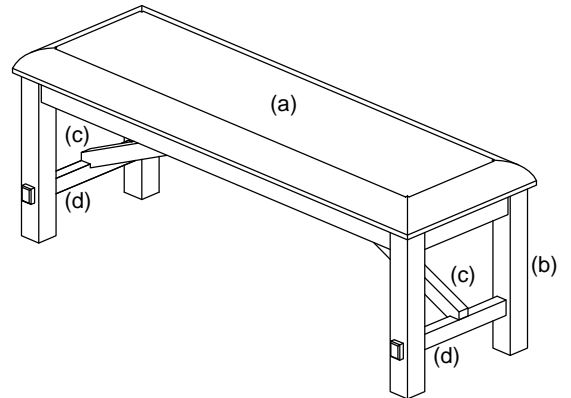

ASSEMBLY INSTRUCTIONS

STEP 1:

- Carefully lay Bench seat upside down on a smooth flat surface to prevent scratches.
- Affix Legs to corner of the Bench seat as show in illustration, insert a Flat Washer (D), Lock Washer (C) and Nut (A) on to the bolts of each Leg. Do not fully tighten.
- Insert 2 Short Stretchers between the legs, fasten with Wood Screw using phillip-head screwdriver (not provided).(See Detail B)

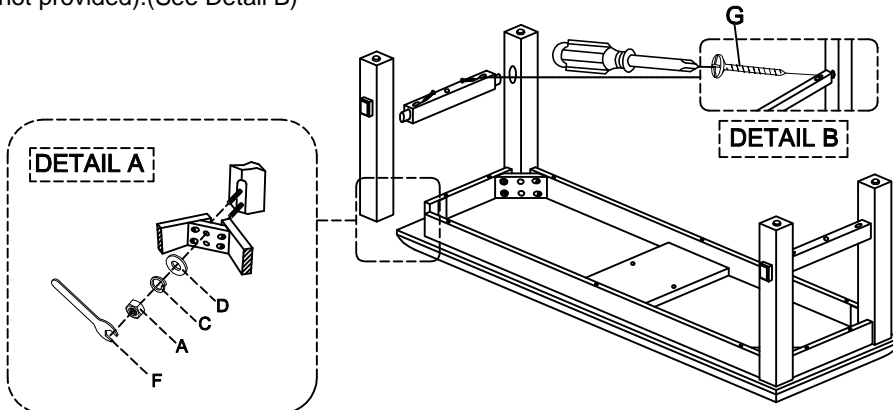

STEP 2:

- Insert 2 Long Stretchers between the Short Stretchers by inserting a Flat Washer (D), Lock Washer (C) with Bolt (B) as show in illustration. (See Detail C & D).
- Tighten screws with provided Allen Key (E) by turning clockwise until secure.
- Once all Legs and Stretchers are in place, fully tighten nuts by using clockwise using proved Key Wrench until secure.

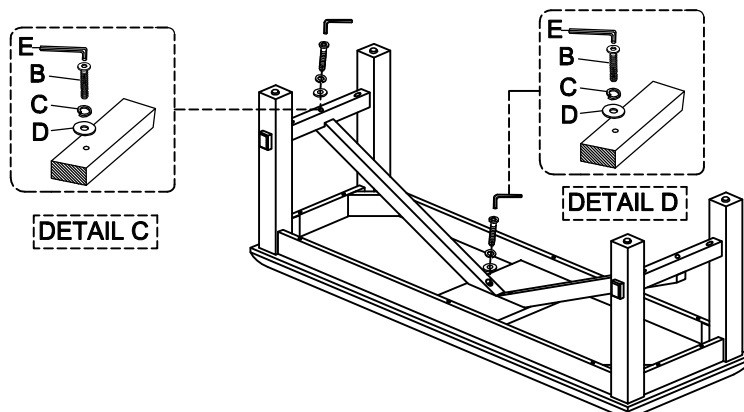

NOTES:

The use of power tools for assembly is not recommended. Power tools can damage hardware or split wood.