

ASSEMBLY INSTRUCTION

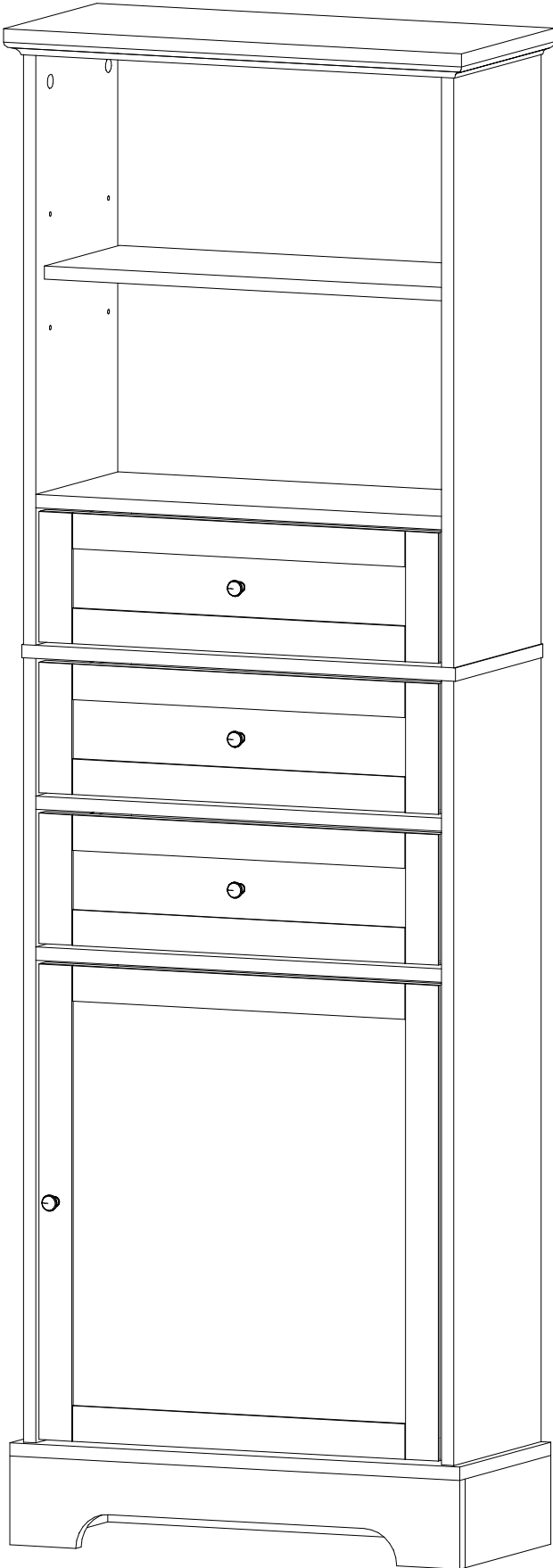

ASSEMBLY INSTRUCTION

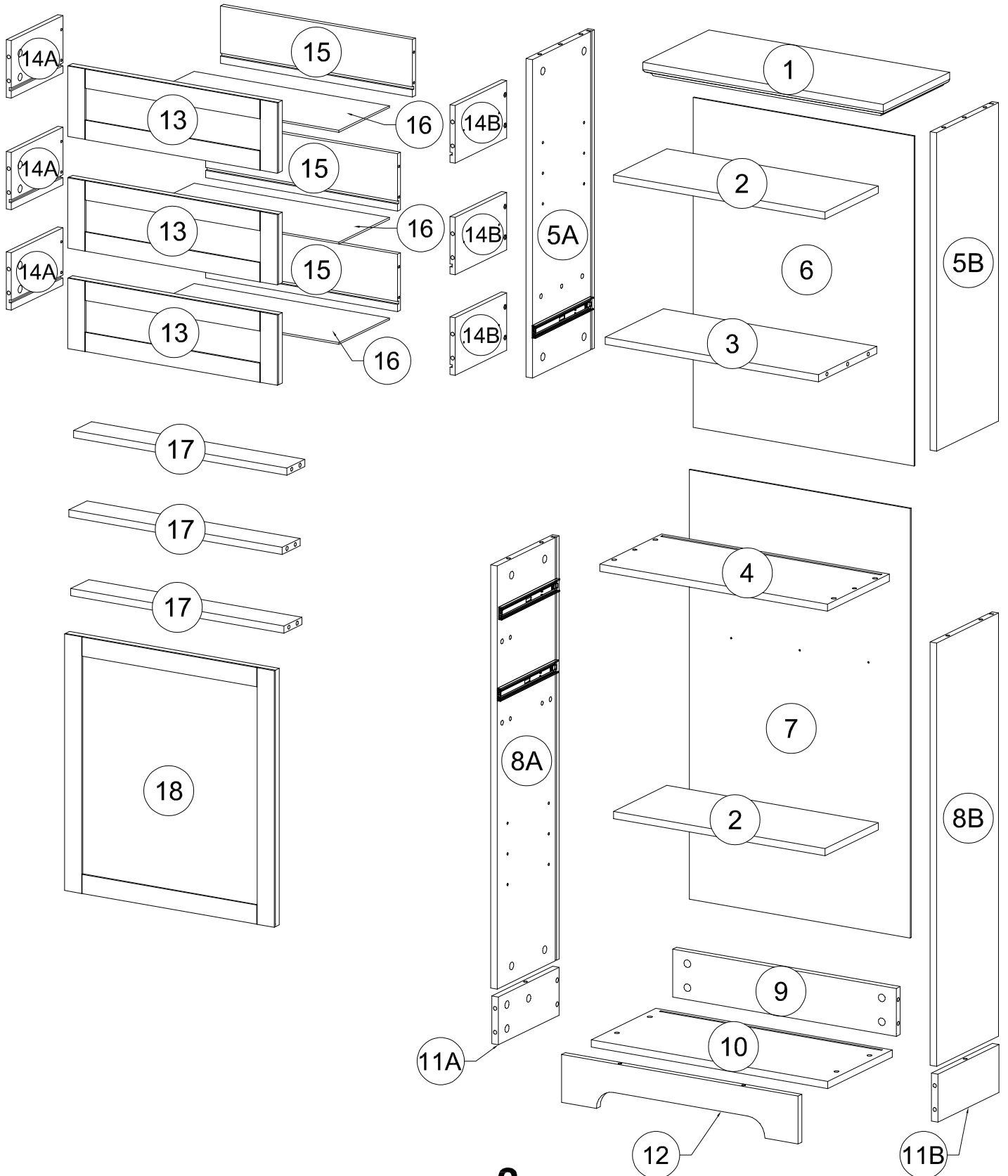

Part List

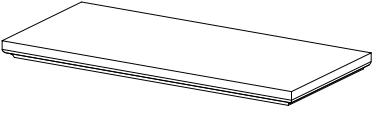
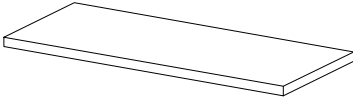
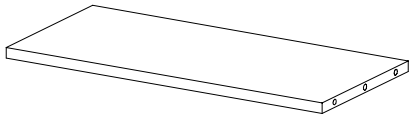
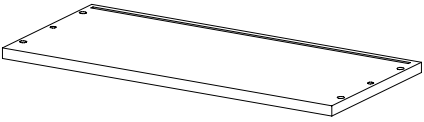
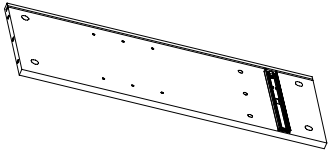
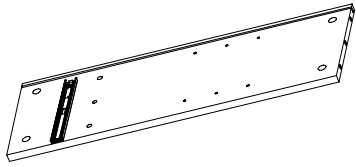
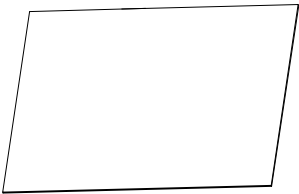
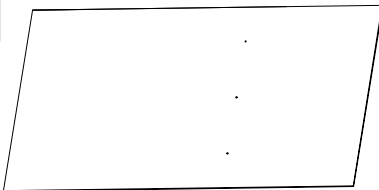
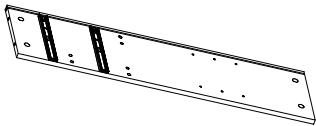
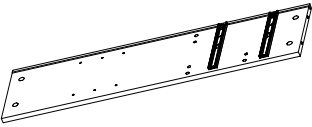
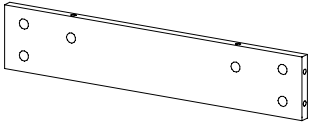
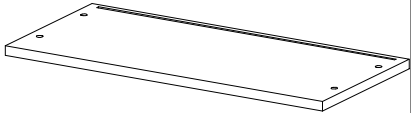
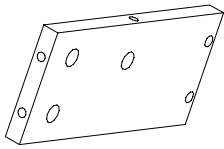
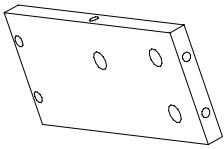
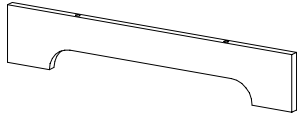
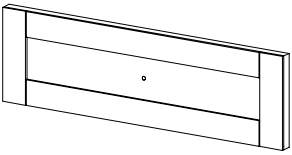
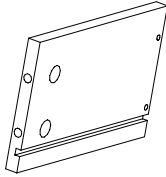
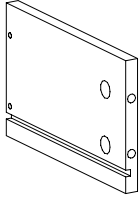
<p>1</p>  <p>The top of the cabinet-1pc</p>	<p>2</p>  <p>MOVING SHELVES-2pcs</p>	<p>3</p>  <p>FIXED SHELF-1pc</p>
<p>4</p>  <p>CABINET DIVIDING PLATE-1pc</p>	<p>5A</p>  <p>HIP EDGE ON CABINET-1pc</p>	<p>5B</p>  <p>HIP EDGE ON CABINET-1pc</p>
<p>6</p>  <p>Cabinet Back-1pc</p>	<p>7</p>  <p>Cabinet Back-1pc</p>	<p>8A</p>  <p>HIP EDGE UNDER THE CABINET-1pc</p>
<p>8B</p>  <p>HIP EDGE UNDER THE CABINET-1pc</p>	<p>9</p>  <p>Short bar - 1pc</p>	<p>10</p>  <p>CABINET BOTTOM-1pc</p>
<p>11A</p>  <p>Short bar - 1pc</p>	<p>11B</p>  <p>Short bar - 1pc</p>	<p>12</p>  <p>Short bar - 1pc</p>
<p>13</p>  <p>DRAWER-FRONT Panels-3pcs</p>	<p>14A</p>  <p>DRAWER-SIDE Panels-3pcs</p>	<p>14B</p>  <p>DRAWER-SIDE Panes-3pcs</p>

Part List

15

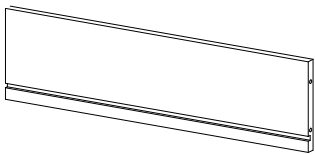

DRAWER-Back Panels-3pcs

16

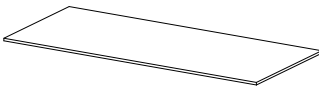

Panel- 3pcs

17

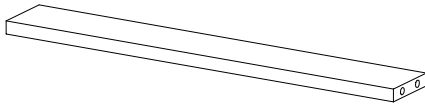





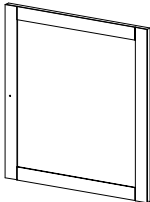

SUPPORT BAR- 3pcs

18

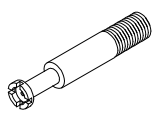
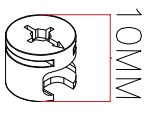
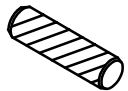
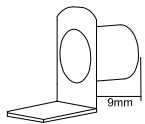
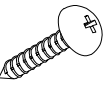
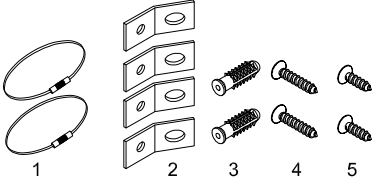
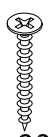
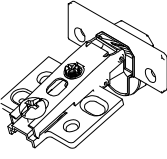

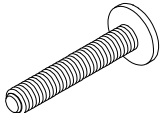
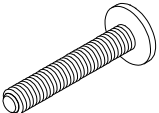
CABINET WINGS-1pc

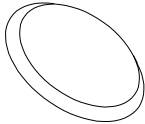

Hardware List

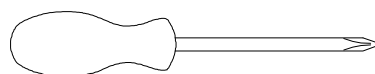
<p>A</p>  <p>Link 1 - 50 pcs</p>	<p>B</p>  <p>Link 2- 12mm - 50 pcs</p>	<p>C</p>  <p>Ø8 x 30 mm Wood dowel 12pcs</p>
<p>D</p>  <p>Support Pin 8pcs</p>	<p>E</p>  <p>M4 x 20 mm Wood Screws 23pcs</p>	<p>F</p>  <p>Wall brackets 1set</p>
<p>G</p>  <p>#4 x 30 mm Wood Screws 12pcs</p>	<p>H</p>  <p>Hinge - 2pcs</p>	<p>R</p>  <p>CABINET DOOR HANDLES - 4pcs</p>
<p>J</p>  <p>M4 x 20mm Hex-Head bolts 3pcs</p>	<p>K</p>  <p>M4 x 25mm Hex-Head bolts 1pc</p>	<p>L</p>  <p>#4 x 15 mm Wood Screws 16pcs</p>
<p>N</p>  <p>Plastic button 50pcs</p>	<p>M</p>  <p>Iron Steel 2pcs</p>	



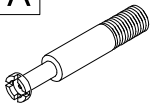

Assembly Tools Required (Not Included)

STEP 1.1: Following below illustration:

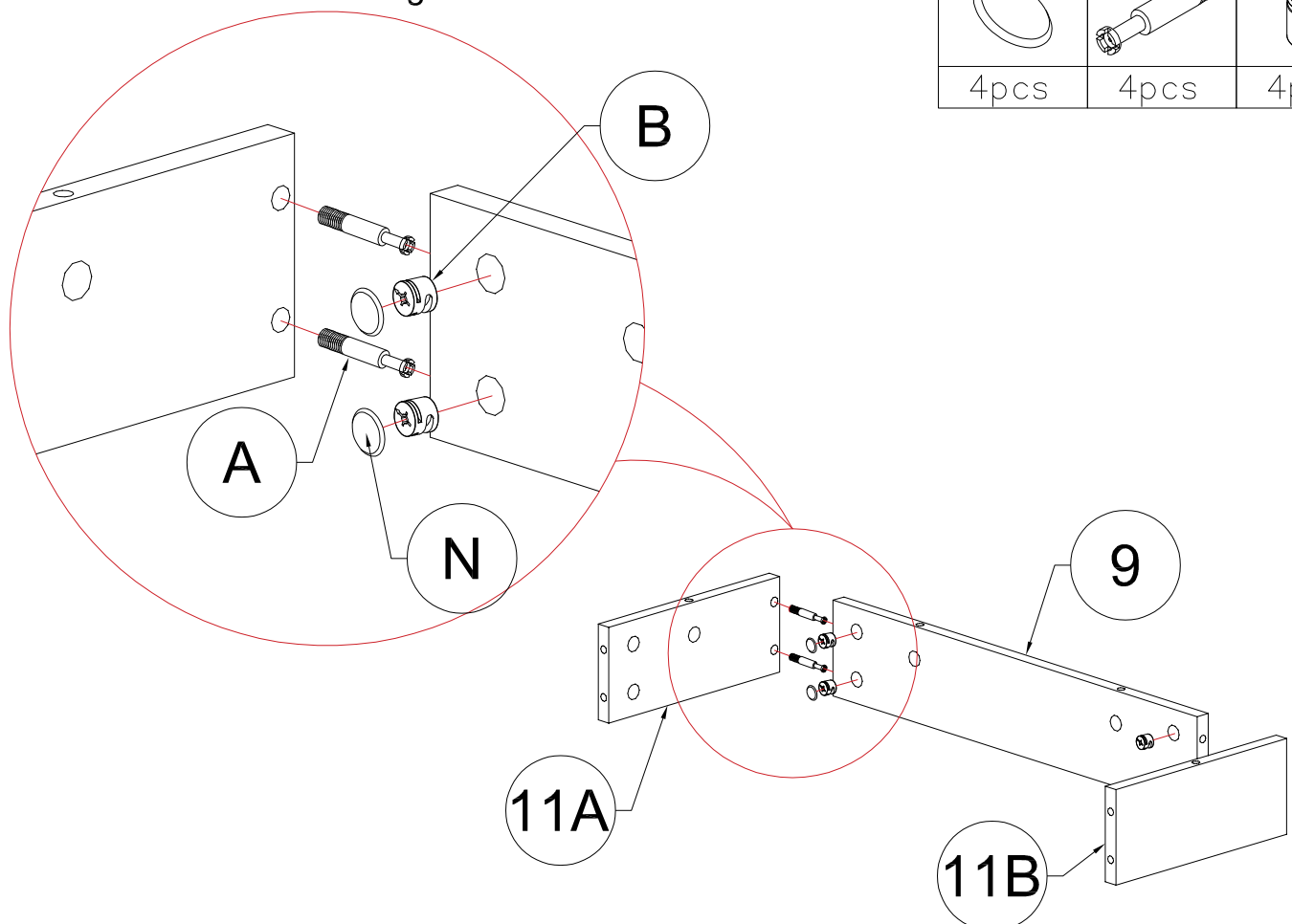
N	A	B
		
4pcs	4pcs	4pcs



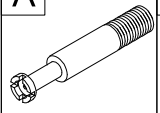

STEP 1.2: Following below illustration:

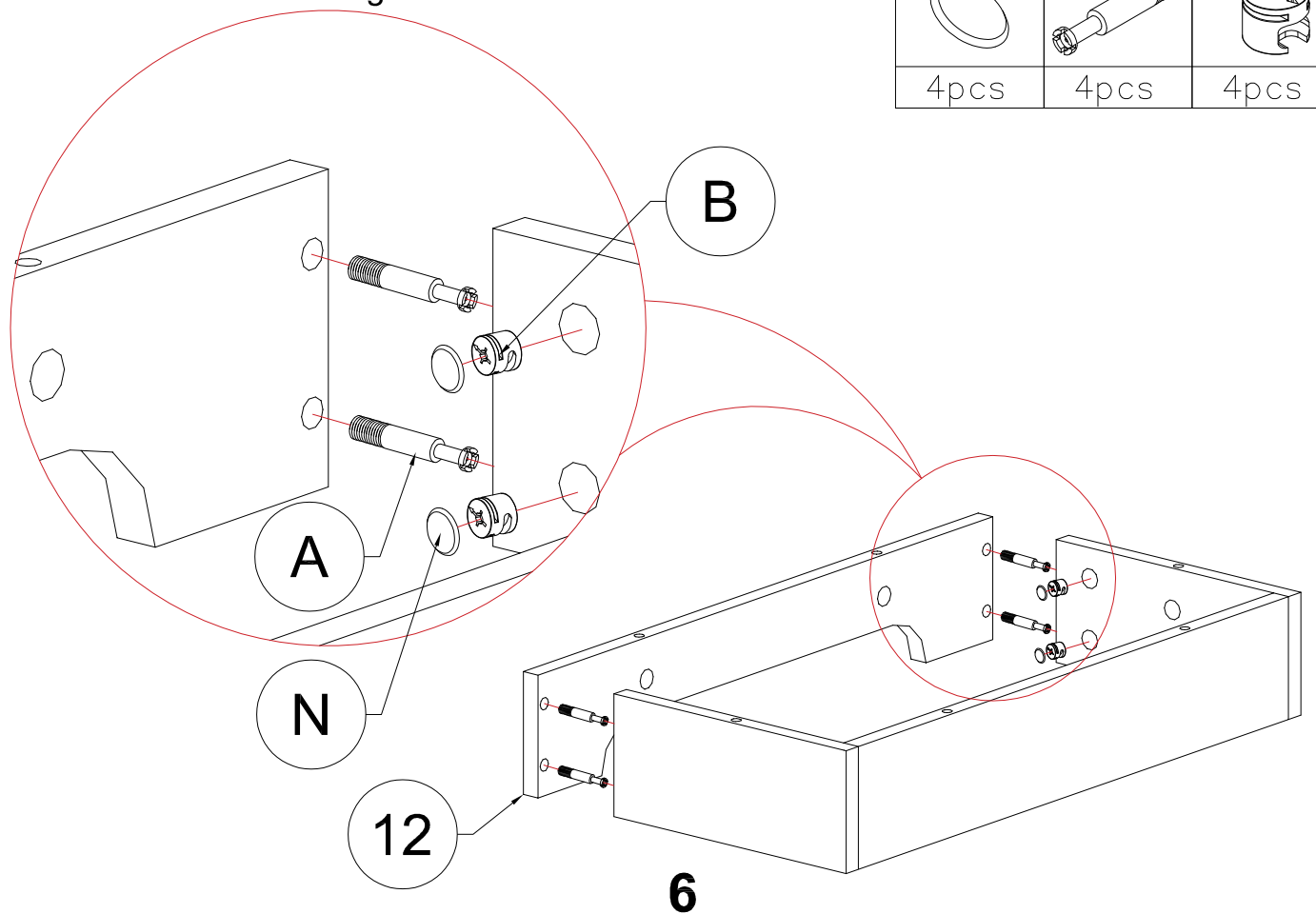
N	A	B
		
4pcs	4pcs	4pcs



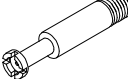

STEP 2: Following below illustration:

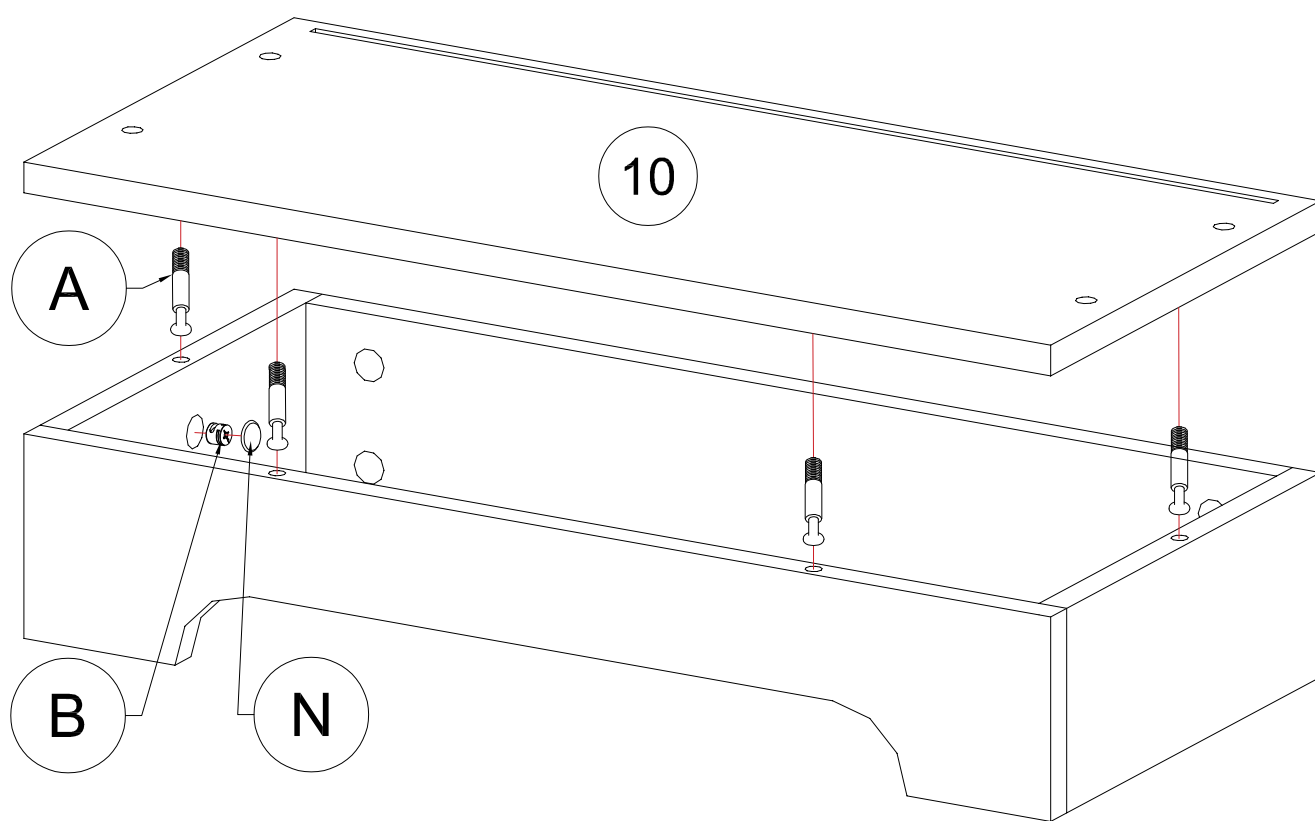
N	A	B
		
4pcs	4pcs	4pcs





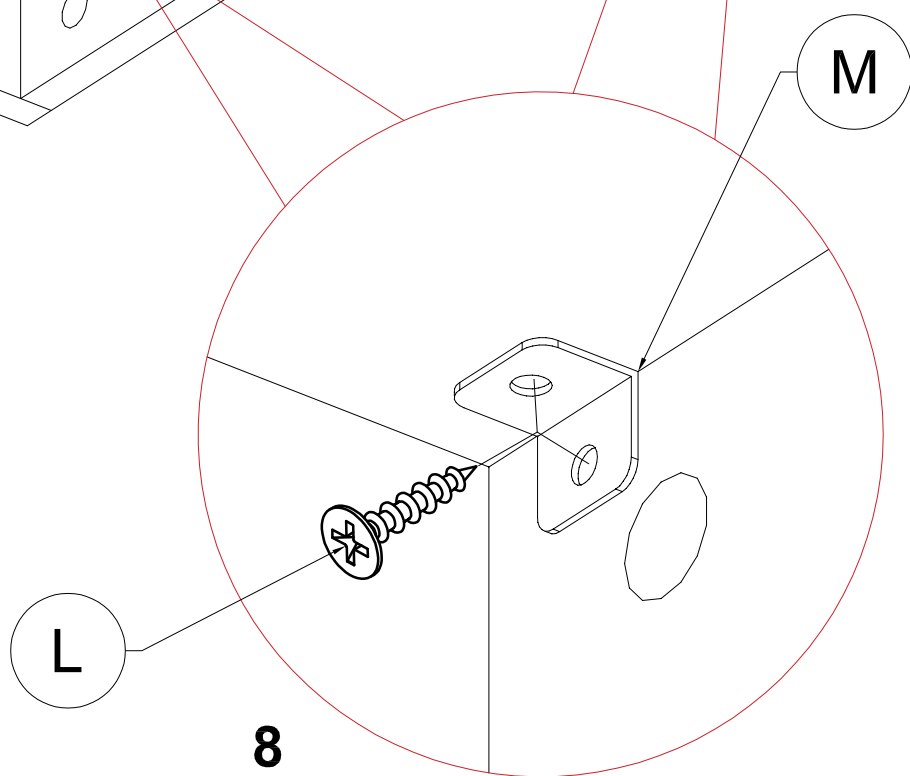
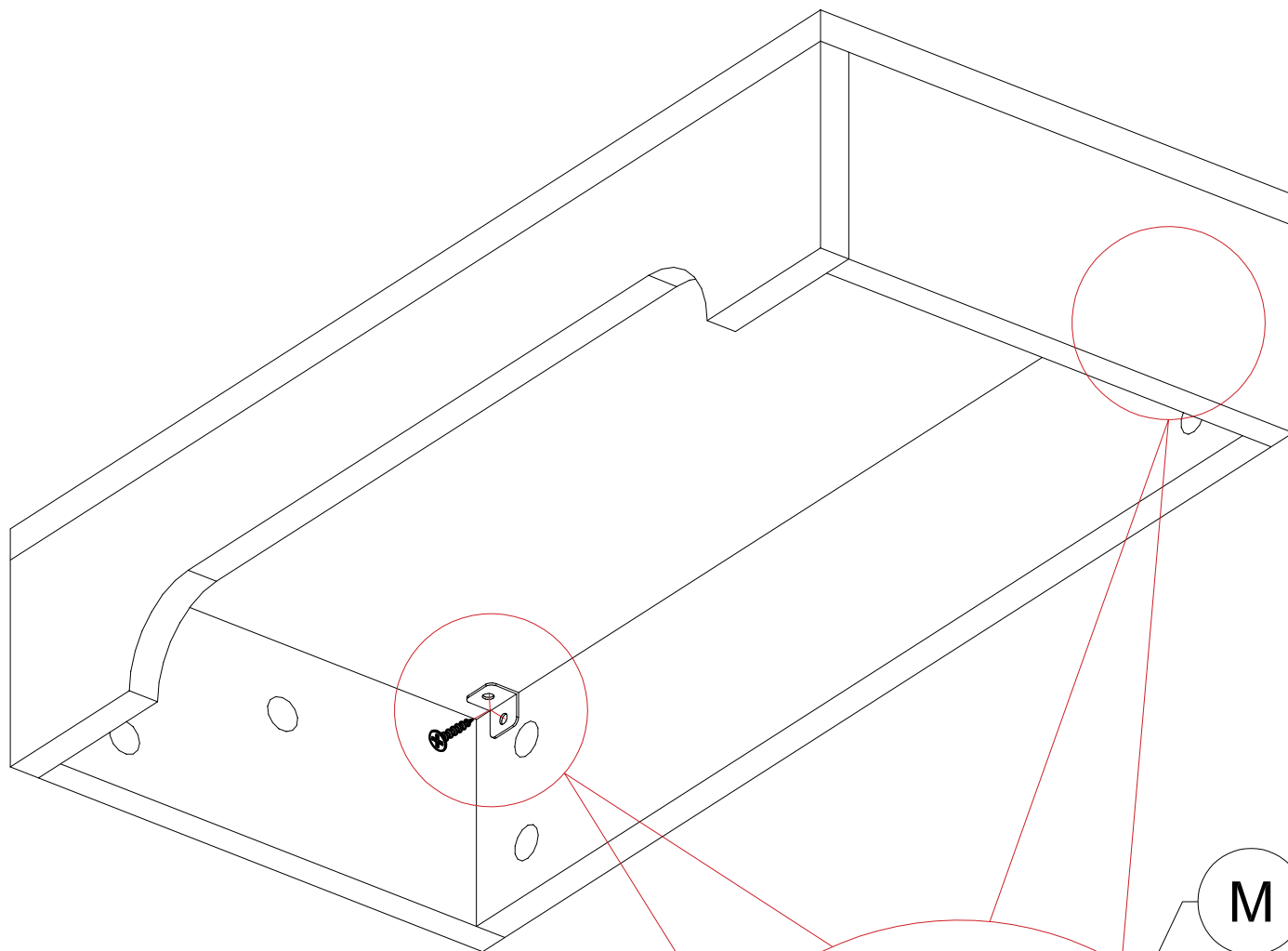

STEP 3: Following below illustration:

M		L	
	2pcs		4pcs

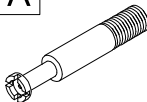

STEP 4: Following below illustration:

N	C	A	B
			
6pcs	6pcs	6pcs	6pcs

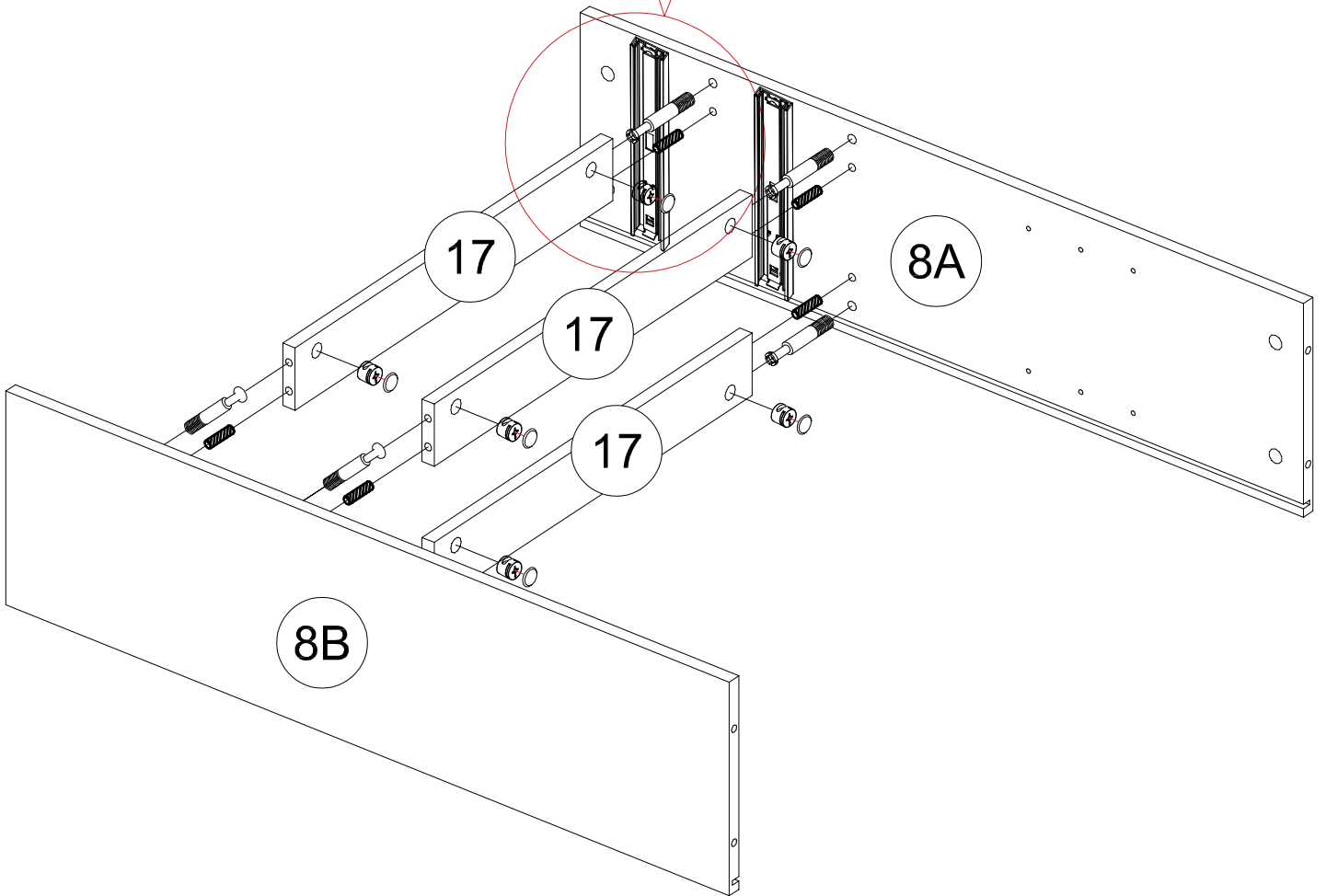
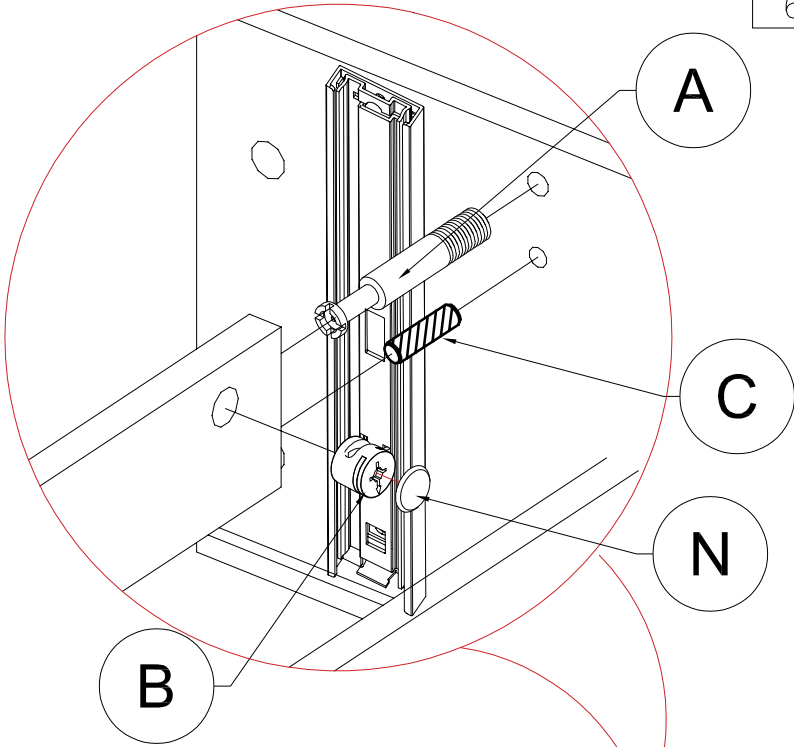

STEP 5: Following below illustration:

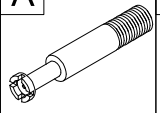
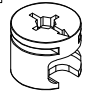

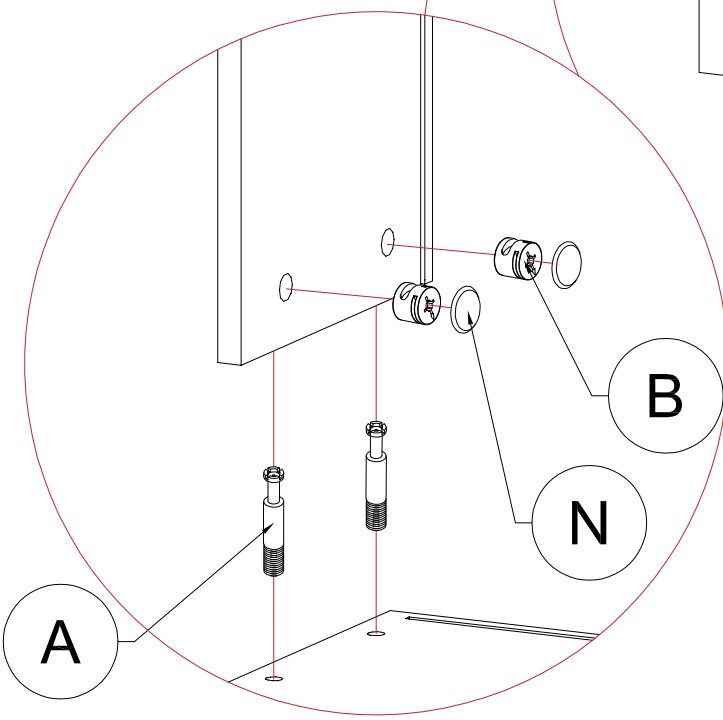
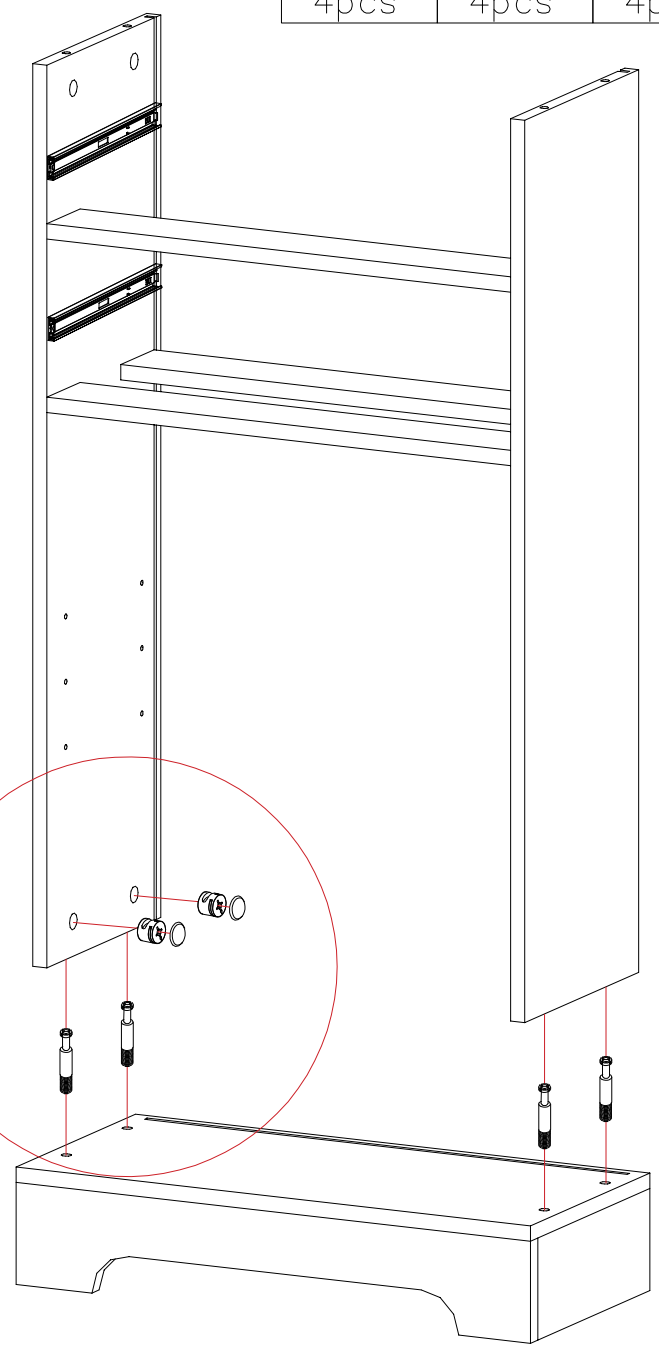
N	A	B
		
4pcs	4pcs	4pcs

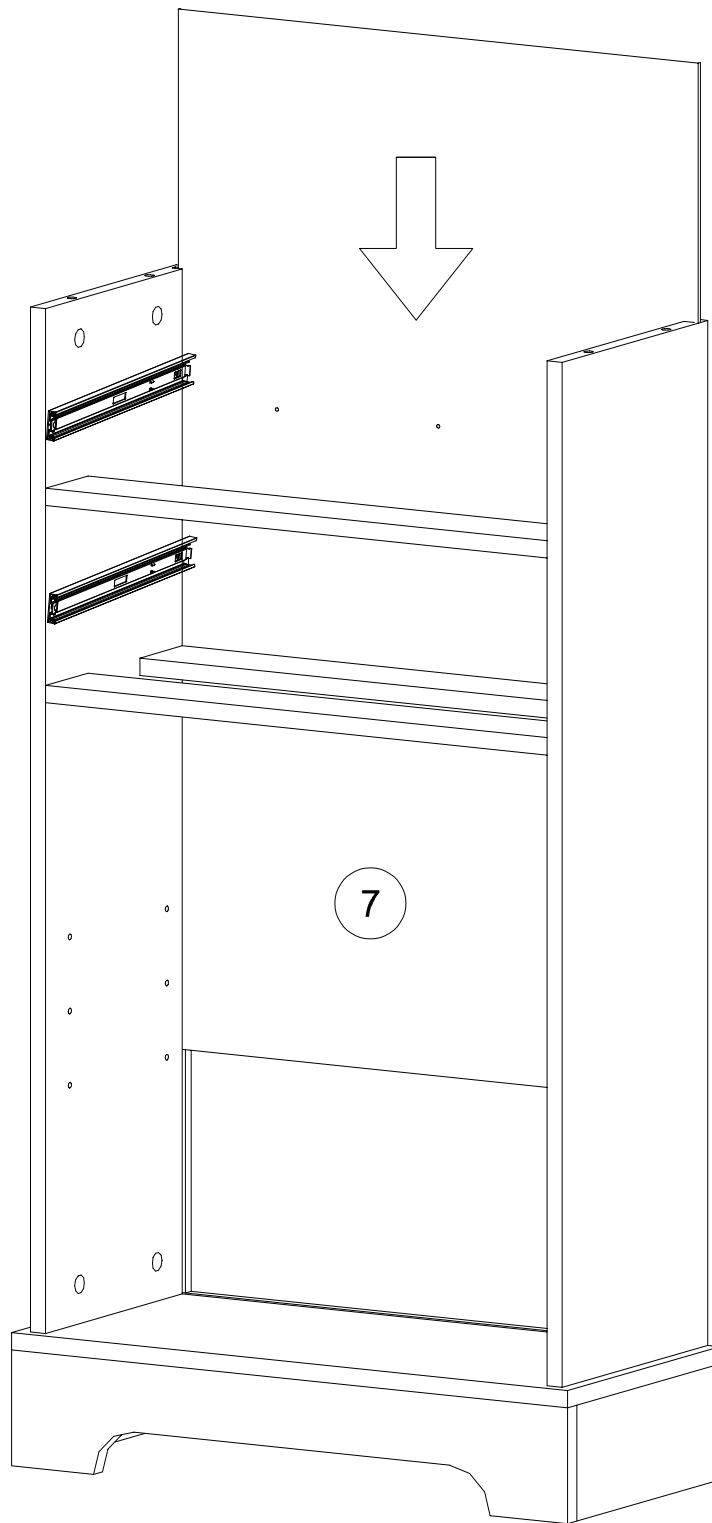

STEP 6: Following below illustration:



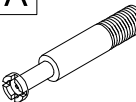

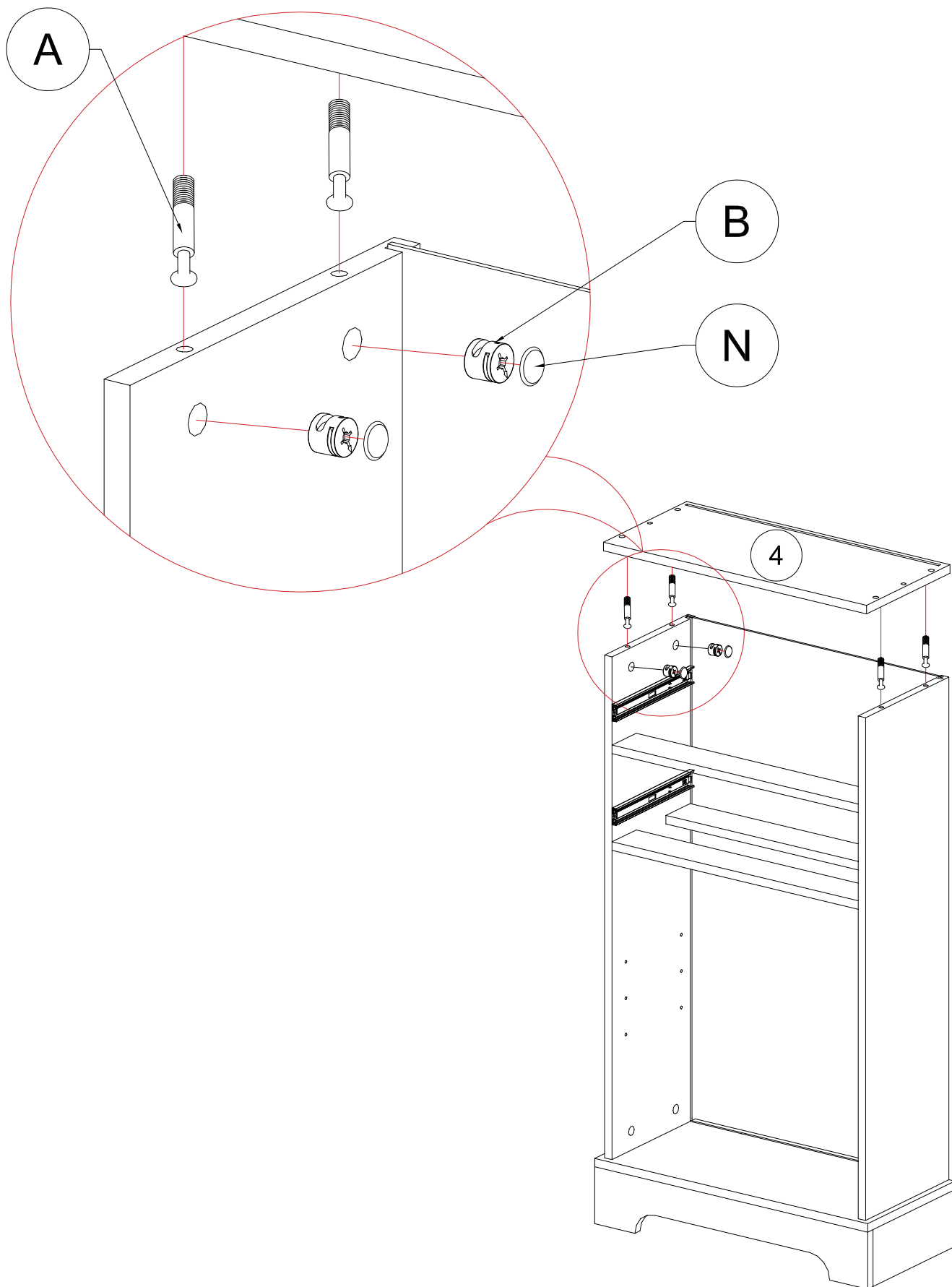

STEP 7: Following below illustration:

N 	A 	B 
4pcs	4pcs	4pcs



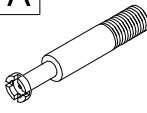

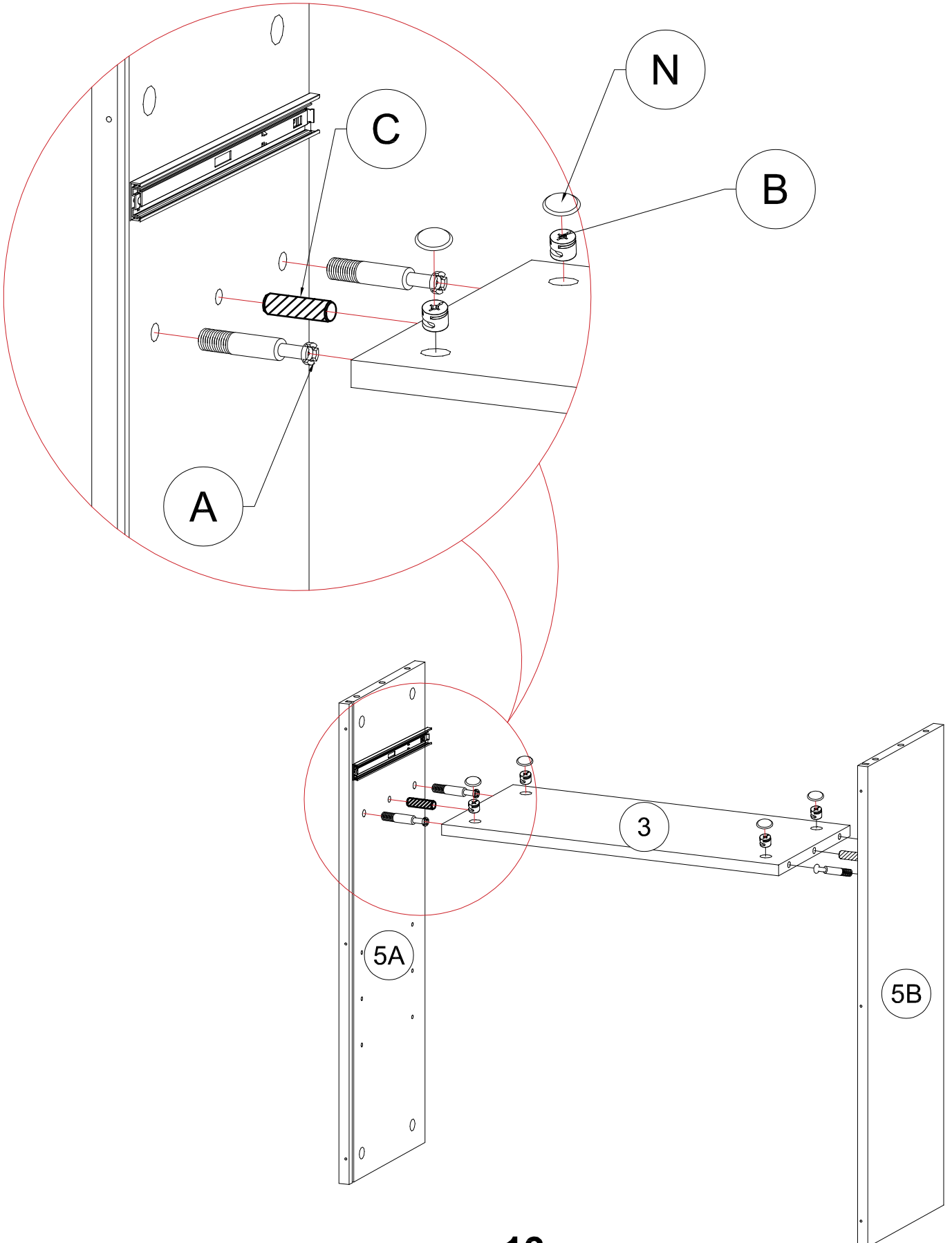

STEP 8: Following below illustration:

N 	C 	A 	B 
4pcs	2pcs	4pcs	4pcs

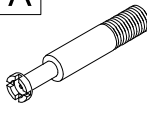

STEP 9: Following below illustration:



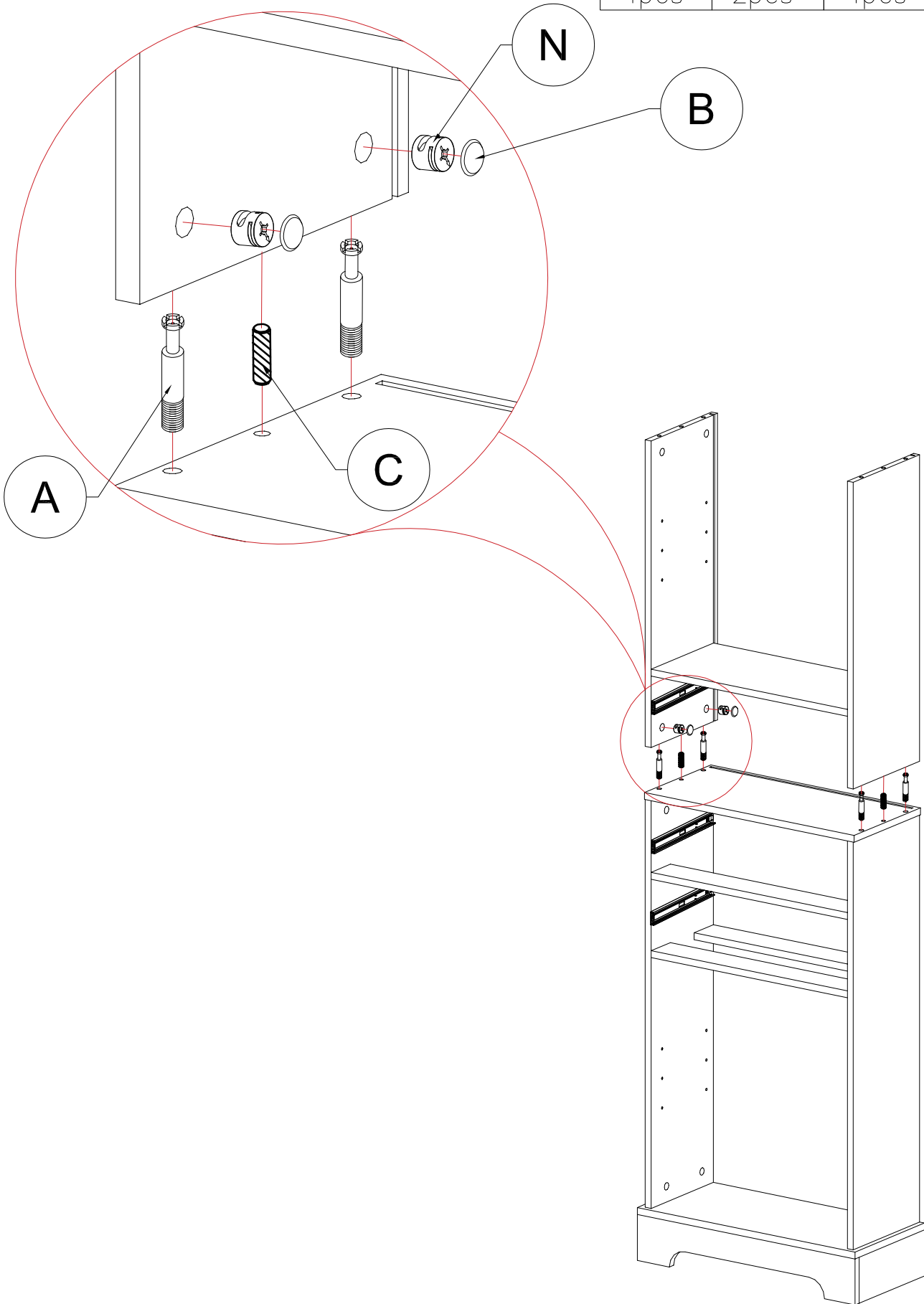

N 	C 	A 	B 
4pcs	2pcs	4pcs	4pcs



STEP 10: Following below illustration:



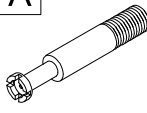

STEP 11: Following below illustration:

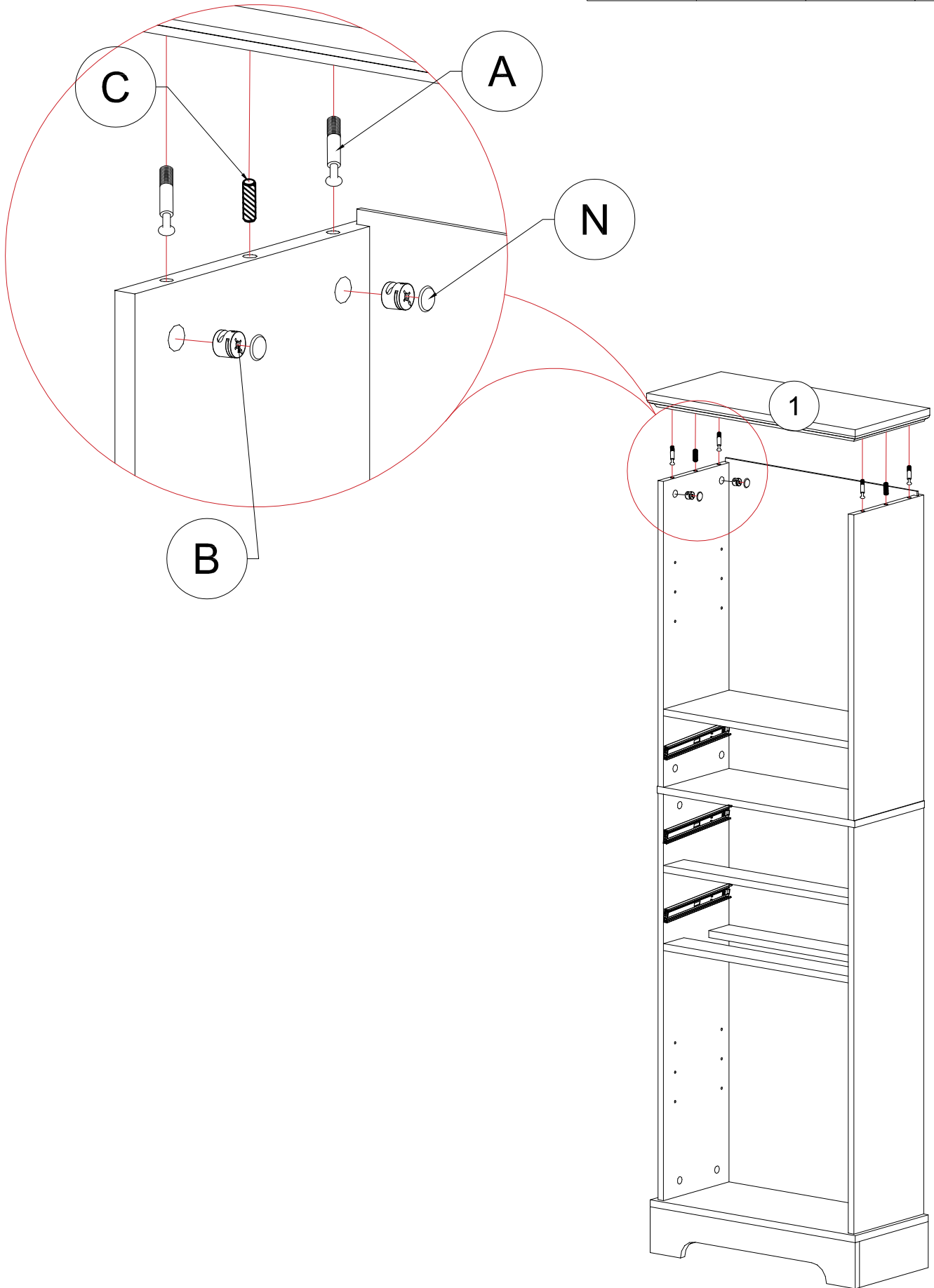
N 	C 	A 	B 
4pcs	2pcs	4pcs	4pcs

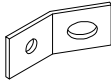

STEP 12: Following below illustration:

F-2	F-5	E
		
2pcs	2pcs	23pcs

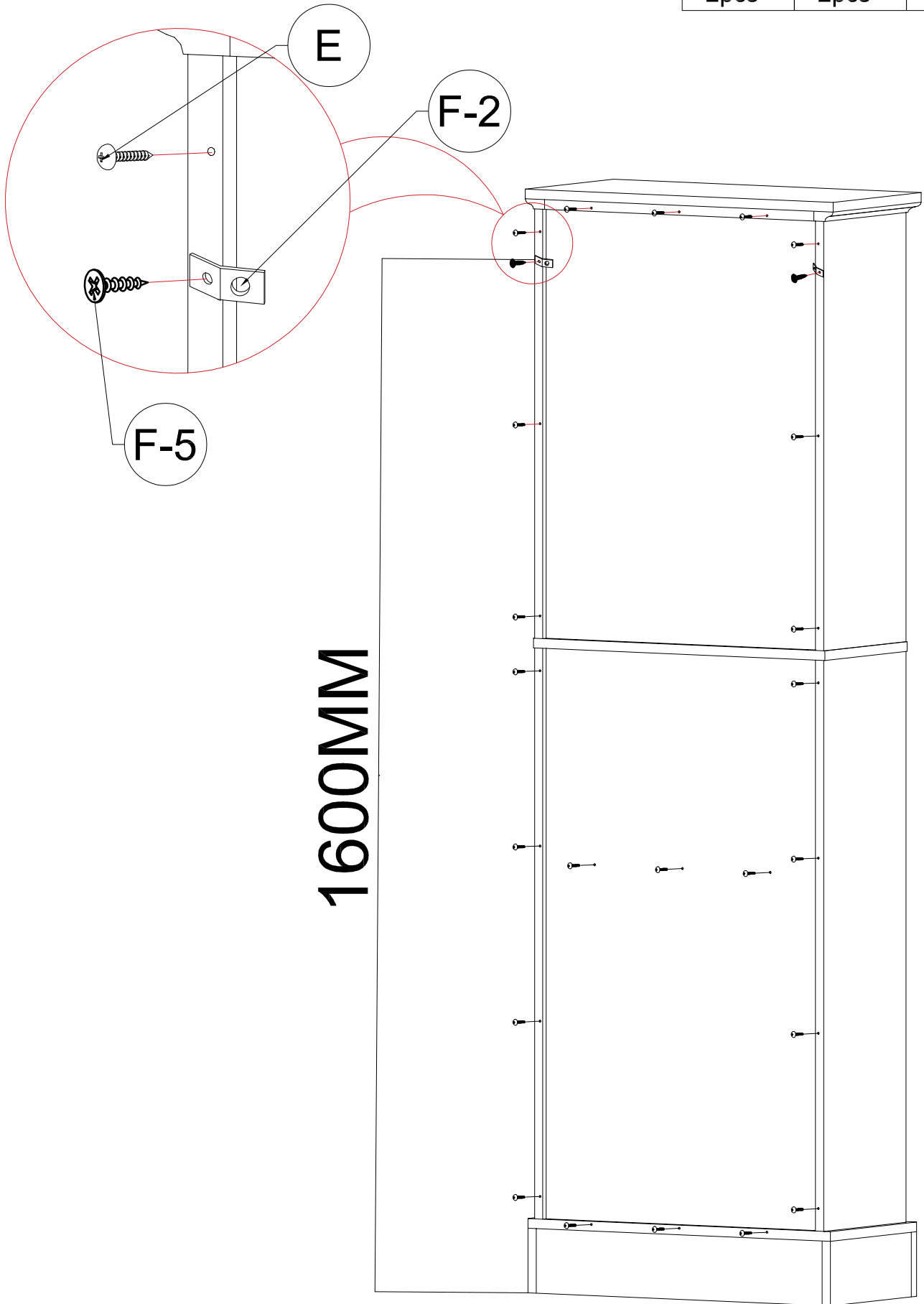

STEP 13: Following below illustration:



D

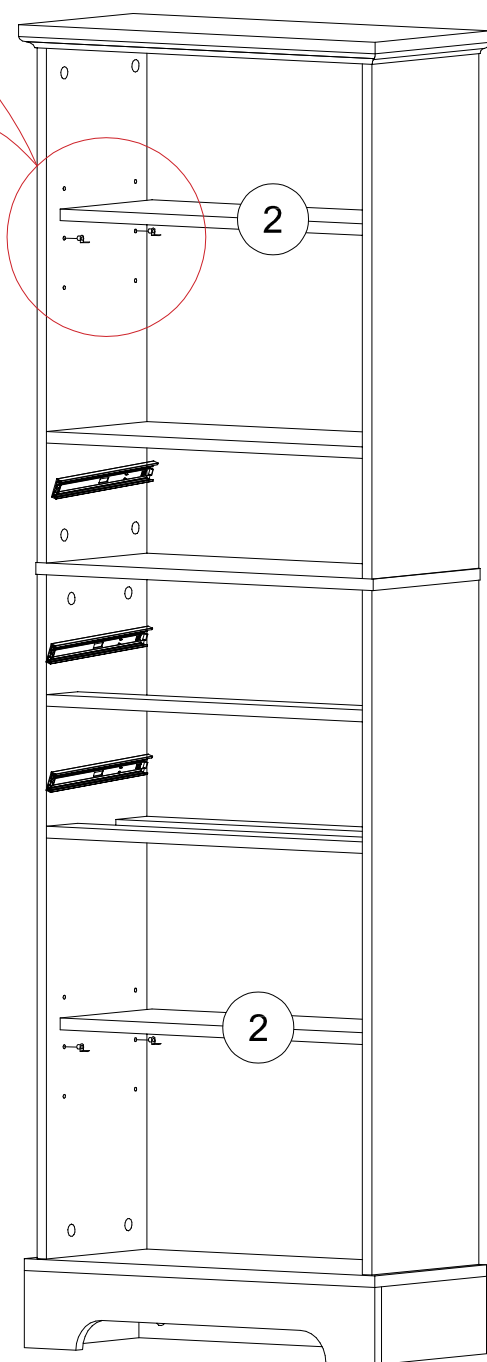
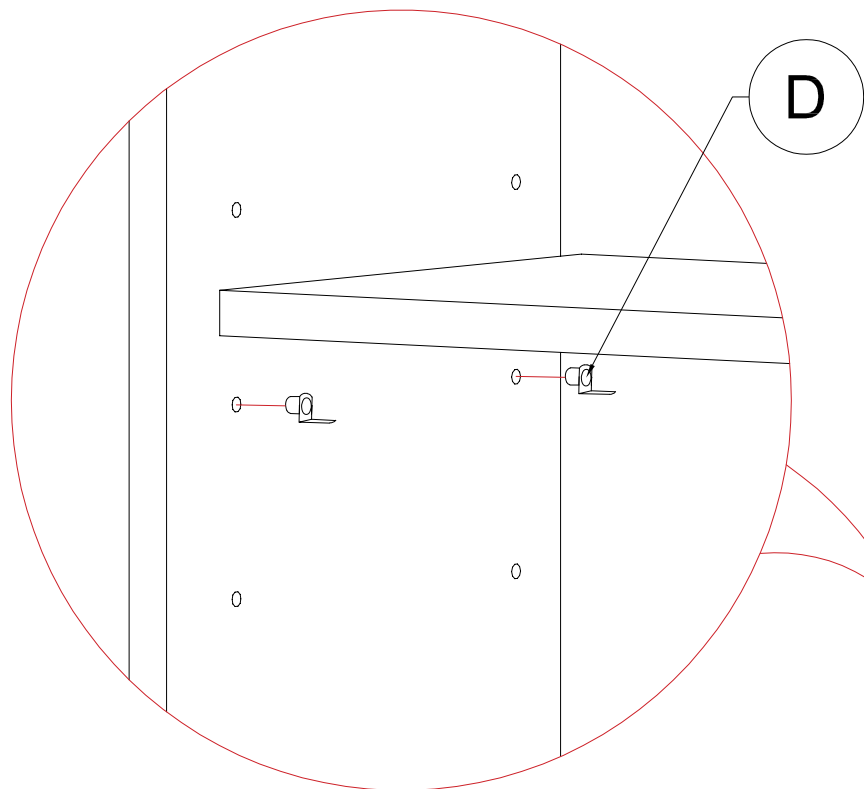

8pcs

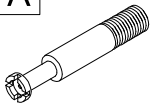

STEP 14.1: Following below illustration:

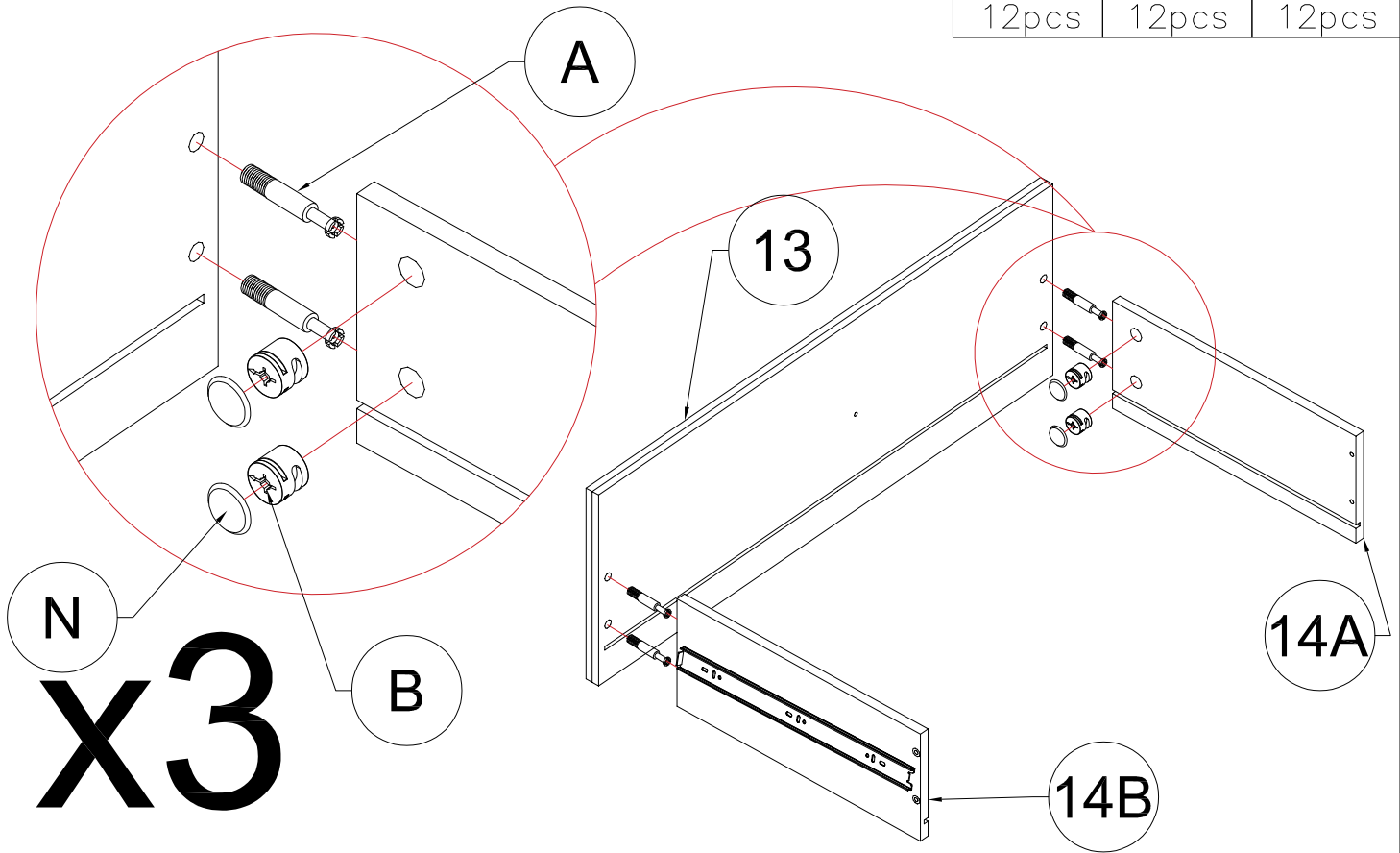

N	A	B
		
12pcs	12pcs	12pcs

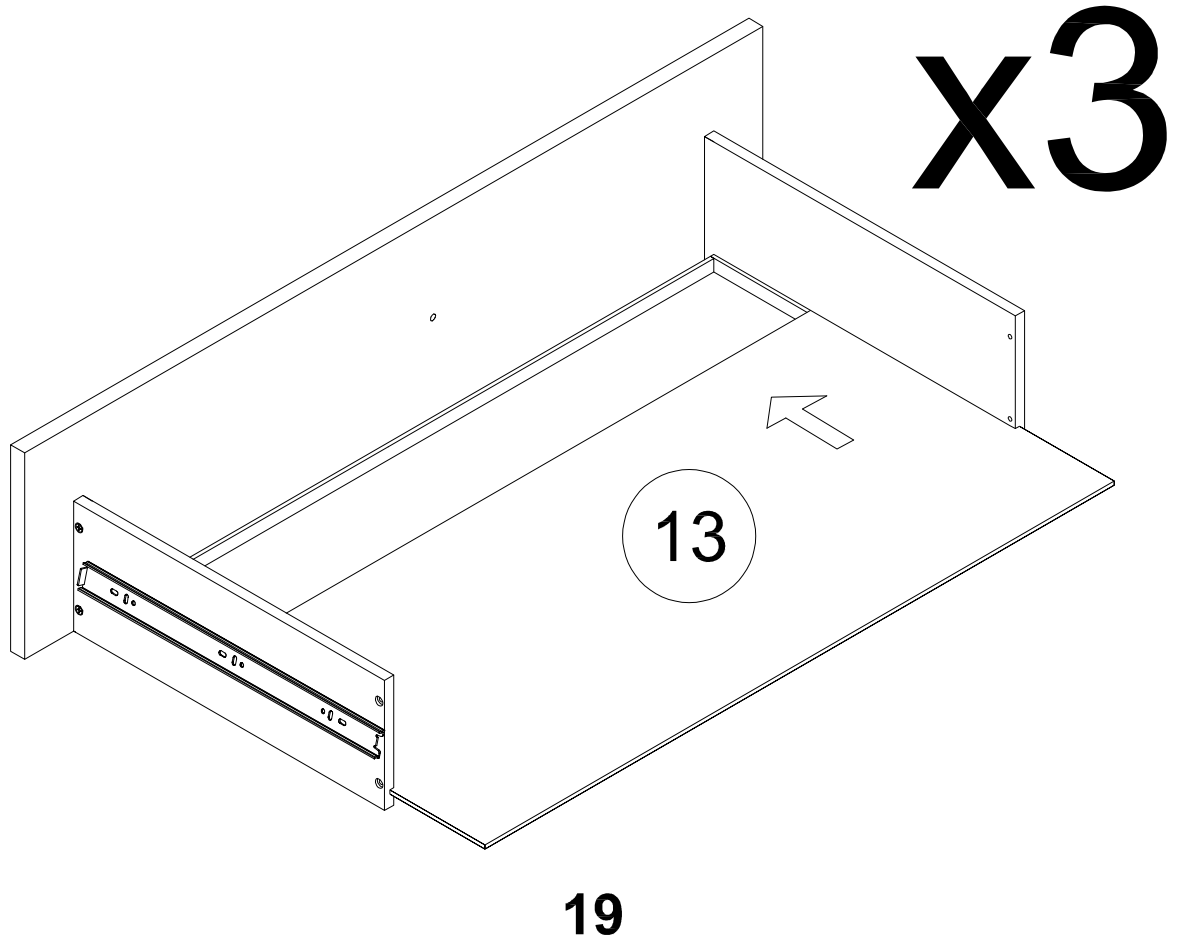

STEP 14.1: Following below illustration:

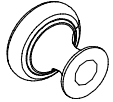
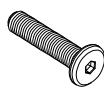

STEP 15: Following below illustration:

R 	J 	G 
3pcs	3pcs	12pcs

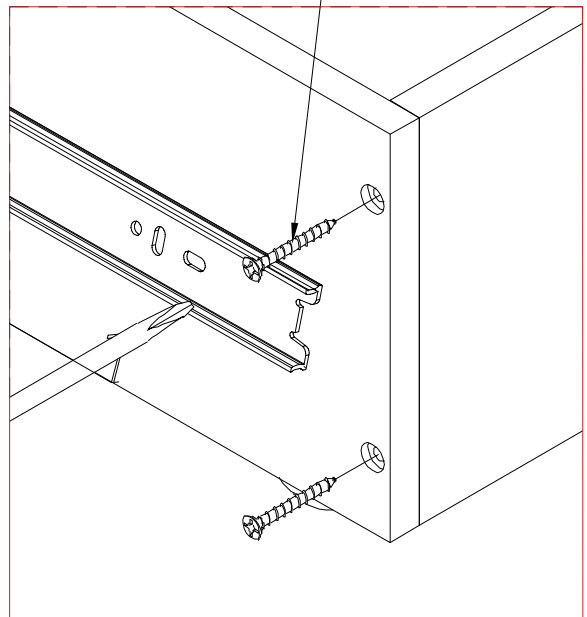
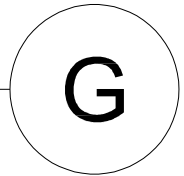
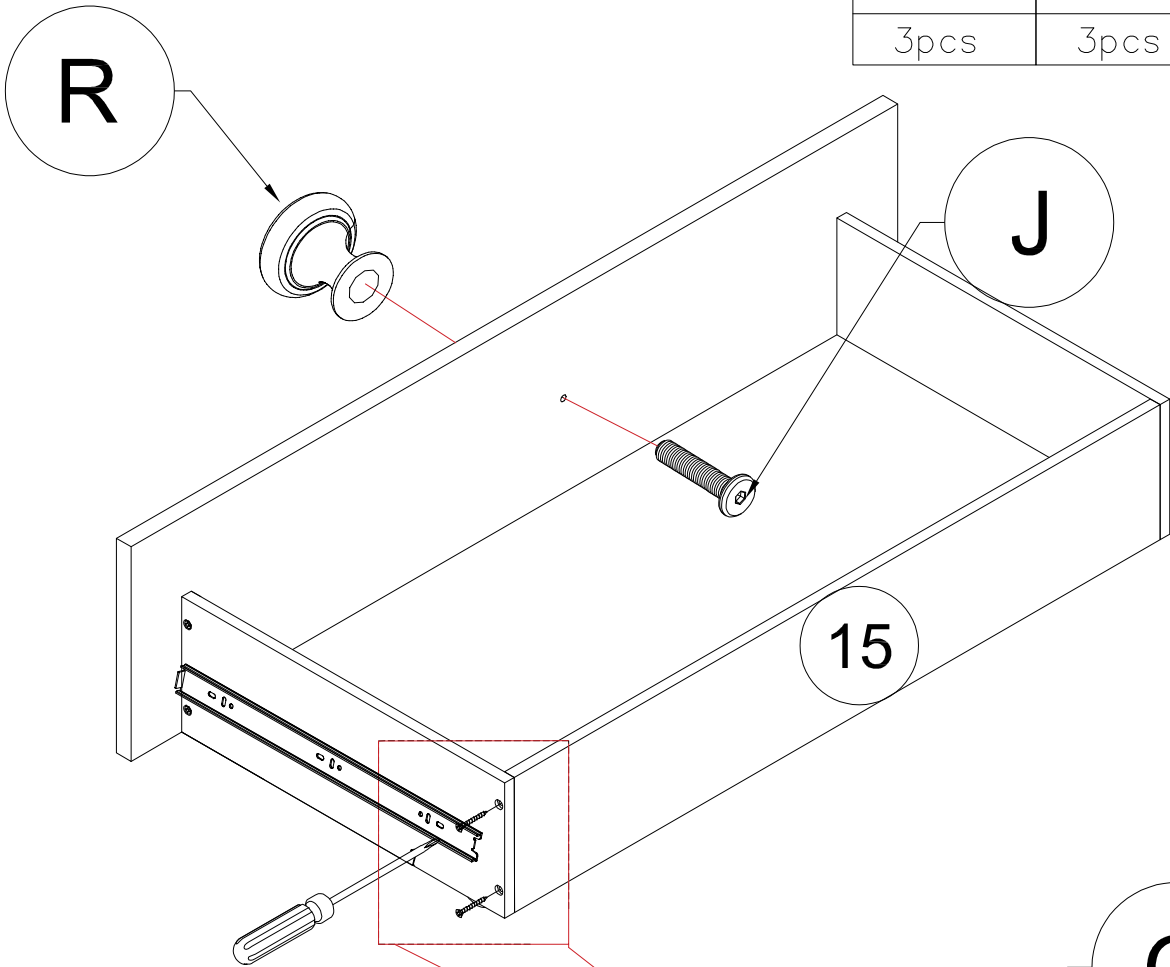

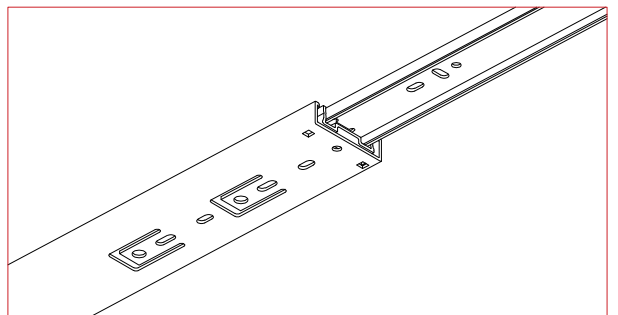
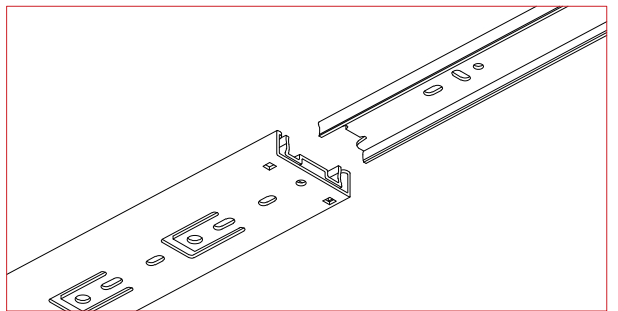
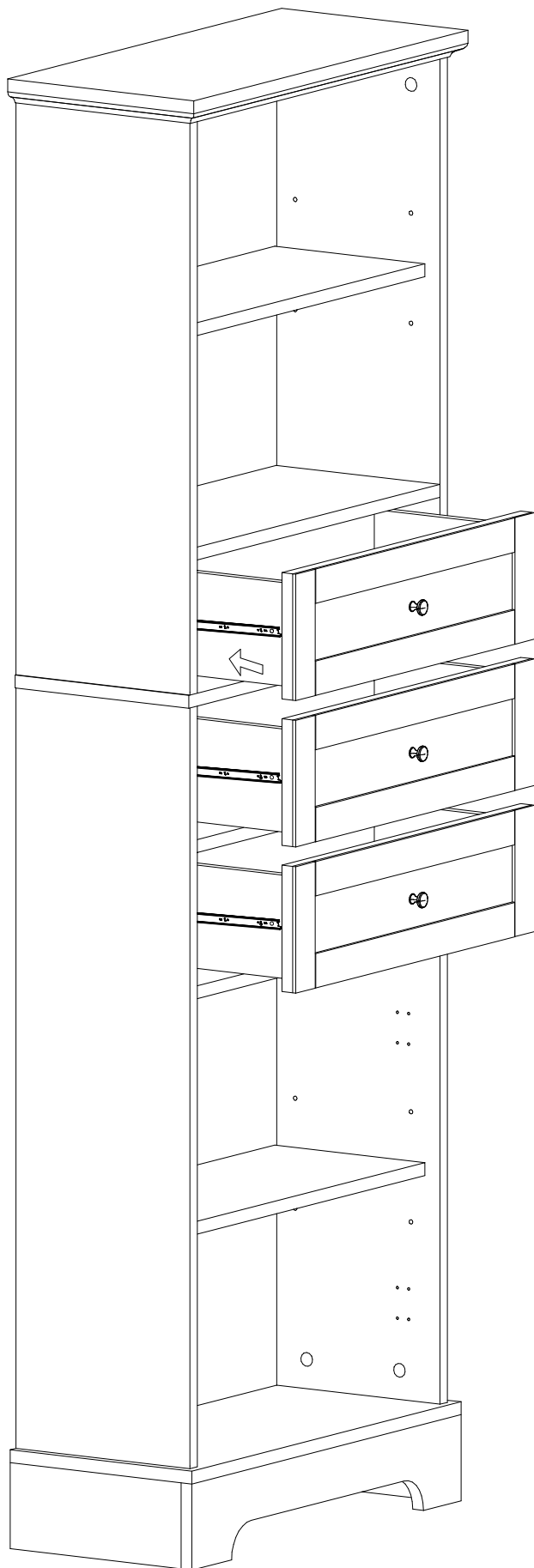

x3

STEP 16: Following below illustration:



STEP 17: Following below illustration:

H 	L 
2pcs	4pcs

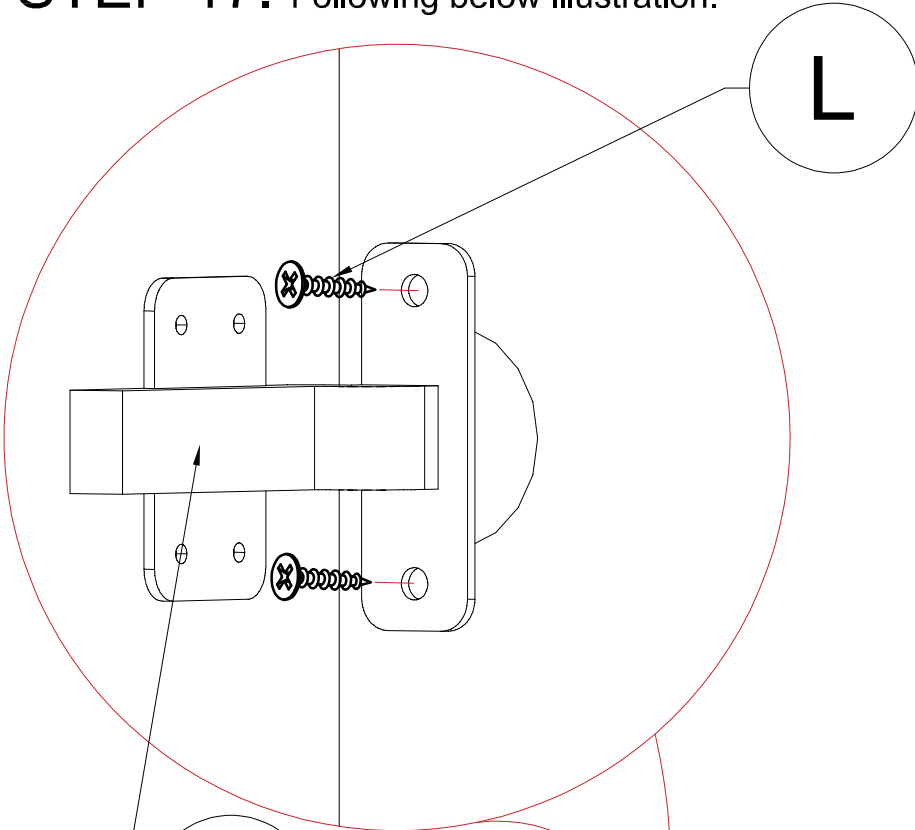

H

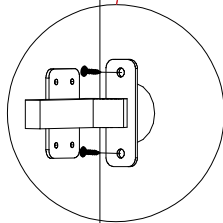

L

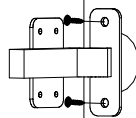

18



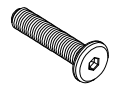

STEP 18: Following below illustration:

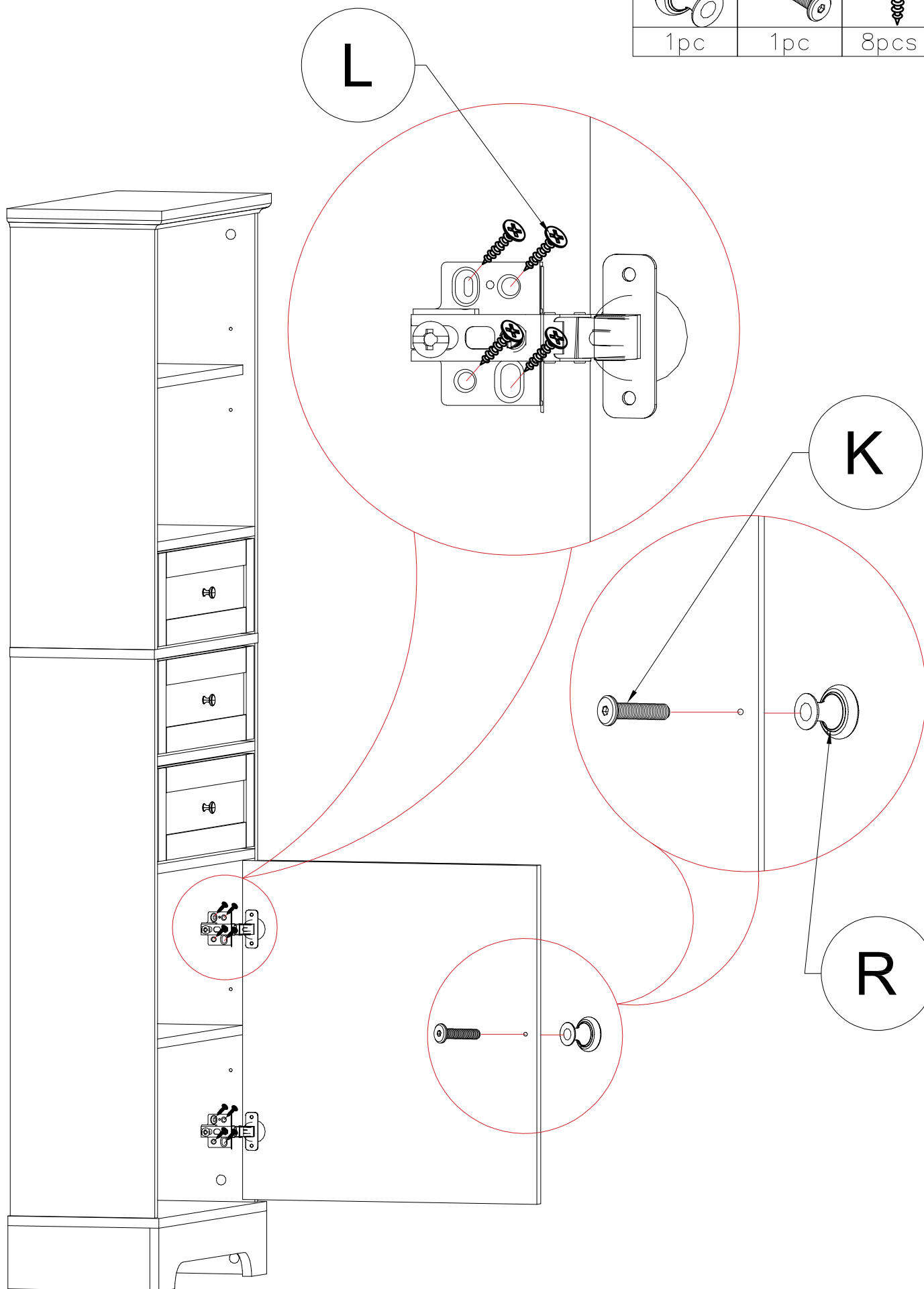
R	K	L
		
1pc	1pc	8pcs

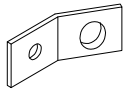

STEP 19: Following below illustration:

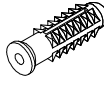
F-2	F-4	F-3
		
2pcs	2pcs	2pcs

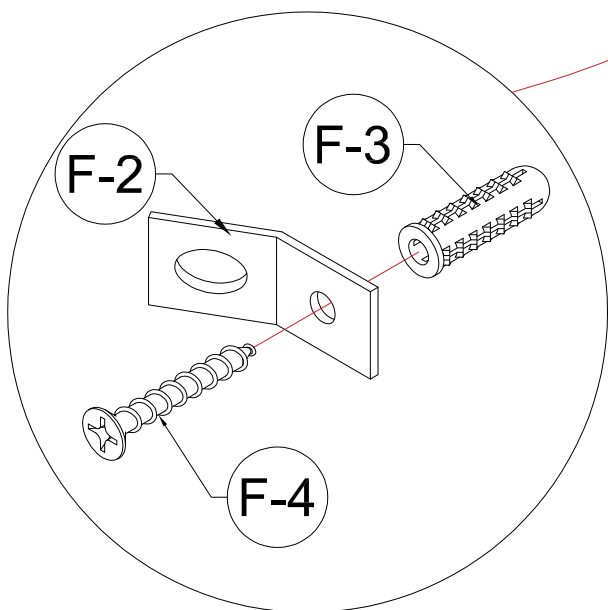
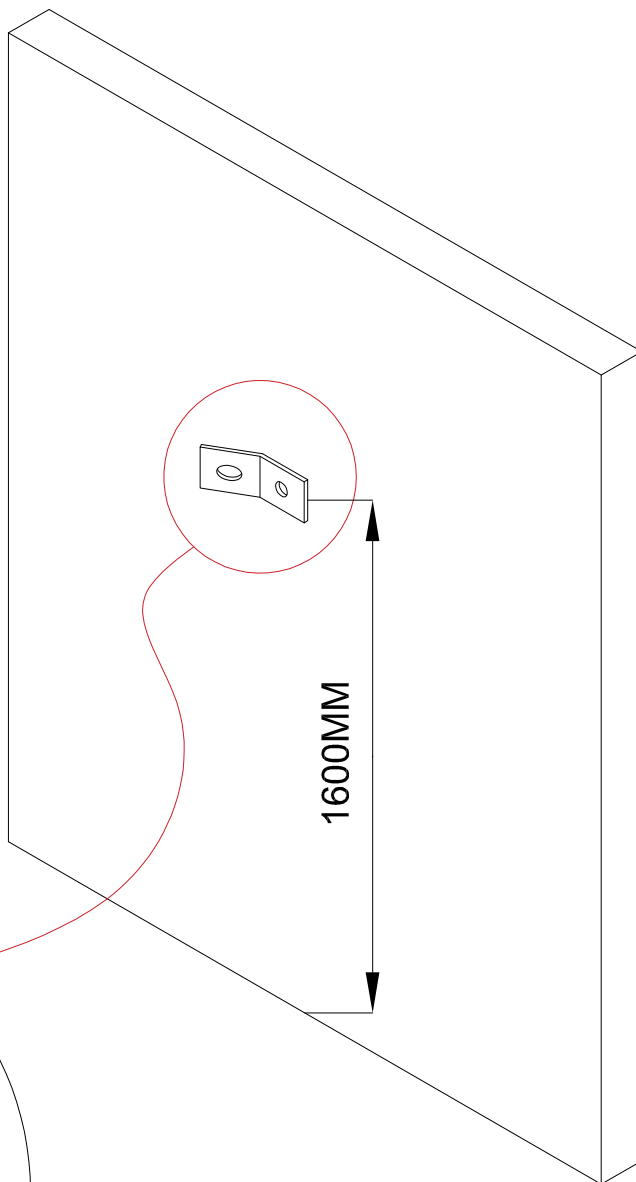

STEP 20: Following below illustration:

F-1



2pcs

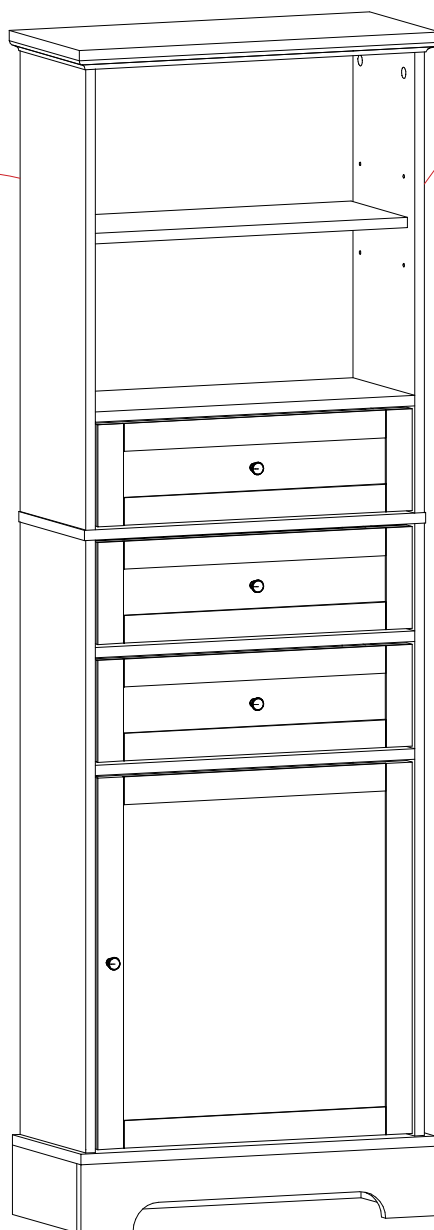
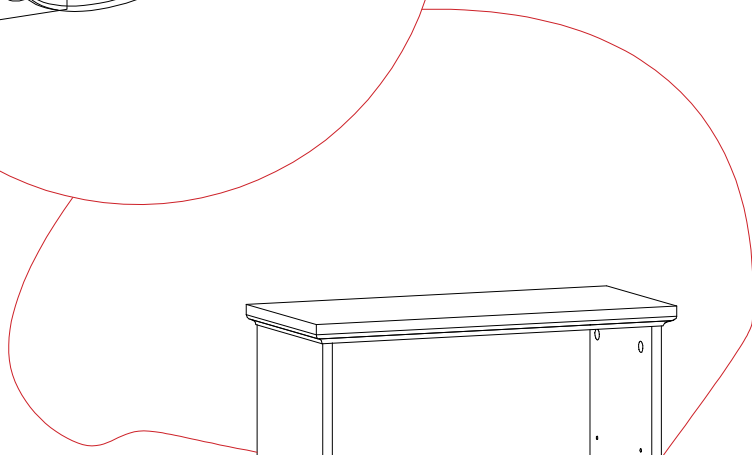
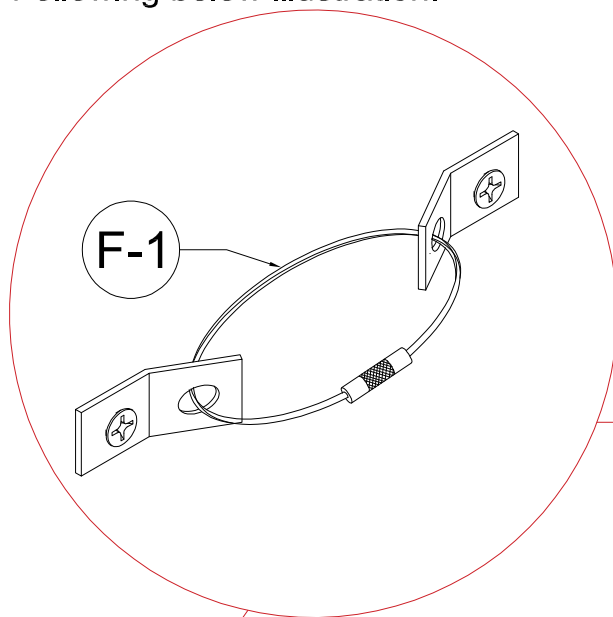

FINISH

