

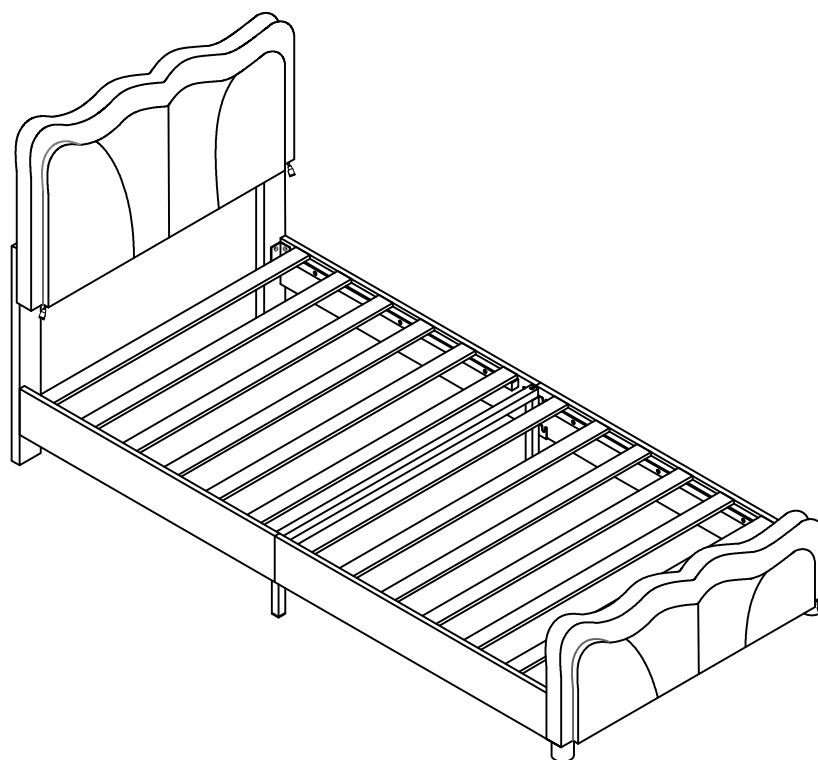

ASSEMBLY INSTRUCTION

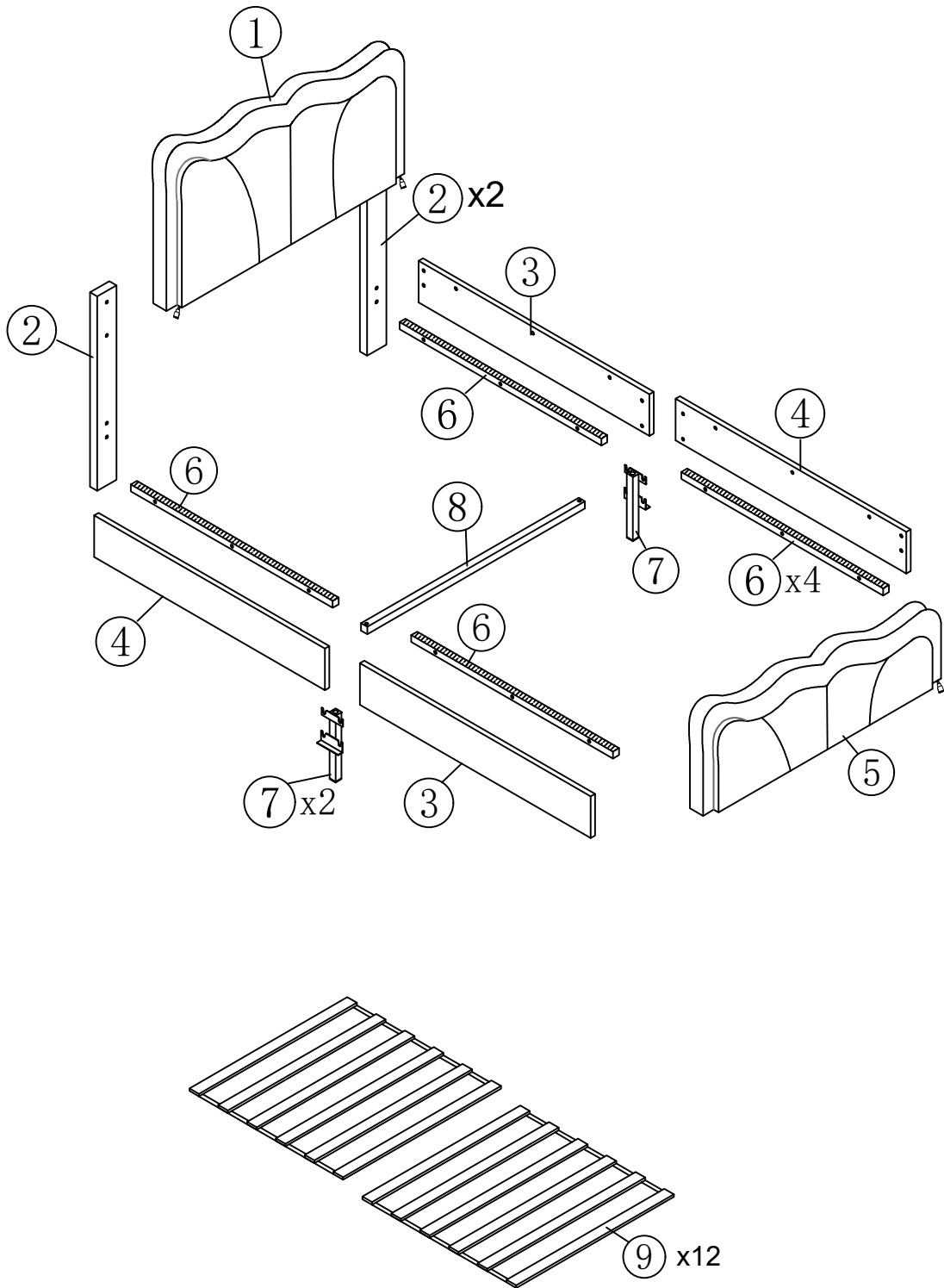





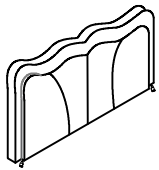
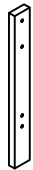
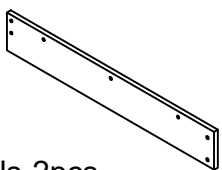
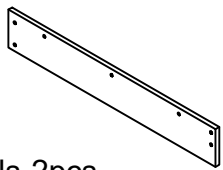
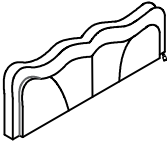
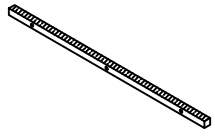

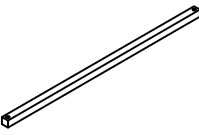
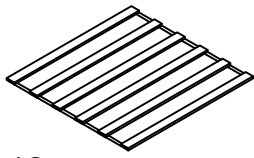



Detail View

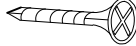

Part List



1  Head board-1pc	2  Head board legs-2pcs	3  Siderails-2pcs
4  Siderails-2pcs	5  Foot board-1pc	6  Side rails support bar-4pcs
7  Side rails support legs-2pcs	8  Cross bar-1pc	9  Slats-12pcs

Hardware List

A  20*70mm	B  Ø8*50mm	C  Ø8*18mm
Allen Key(2pcs)	Bolts(4pcs)	Bolts(24pcs)
D  Ø8*40mm	E  77*33**33*3mm	F  Ø3*16mm
Bolts(14pcs)	"7" Connector(4pcs)	Nails(10pcs)
G  H:40mm	H 	I 
Bed legs(2pcs)	Buckle(5pcs)	Power adapter(1pc)
J 	K 	
LED Connecting line(1pc)	Color controller(1pc)	

Remark: We recommend you assemble your bed in the flat ground.



Step 1

A 	B  M8X50mm 4PCS
--	---

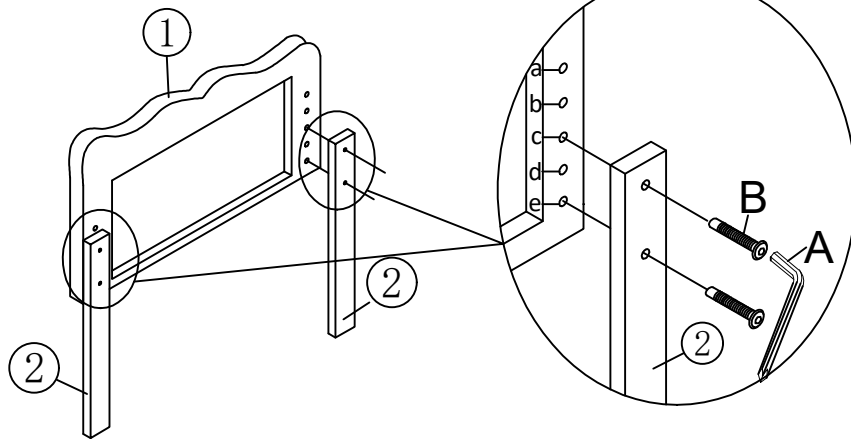
Attention:
You can chose the hole a
and c, or b and d, or c and e.



Step 2 x2

A 	D  M8X40mm 12PCS
--	--

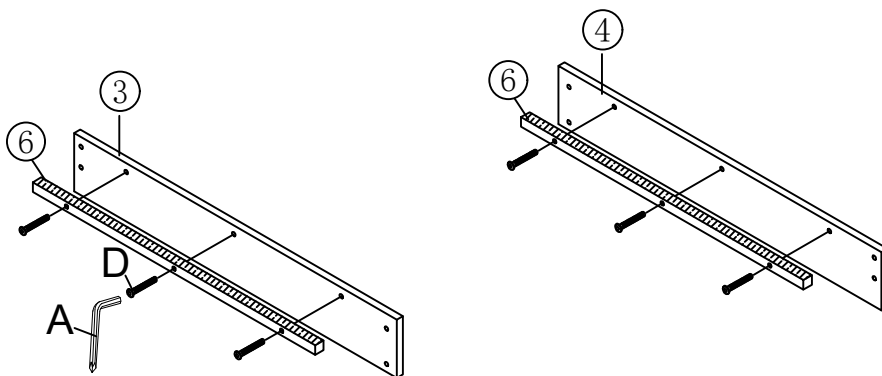

Step 3 x2

A



C



M8X18mm

8PCS

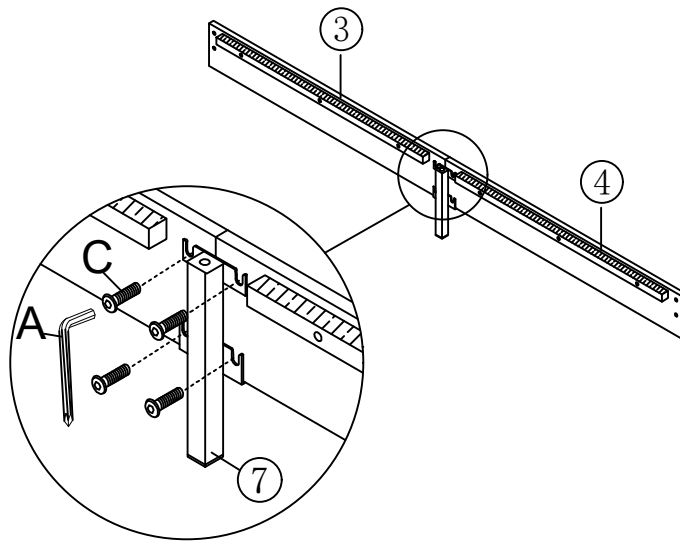

Step 4



G

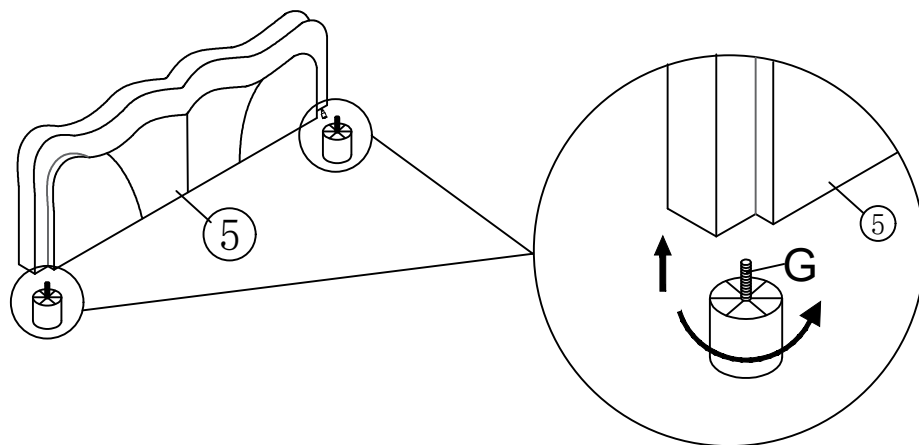

2PCS



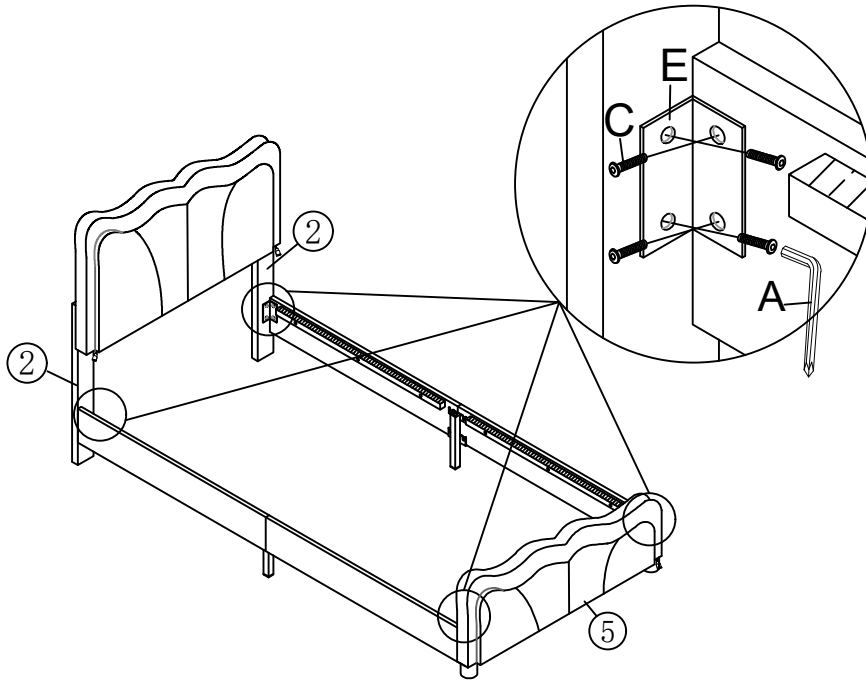

Step 5

A 	C  M8X18mm 16PCS	E  4PCS
---	--	--





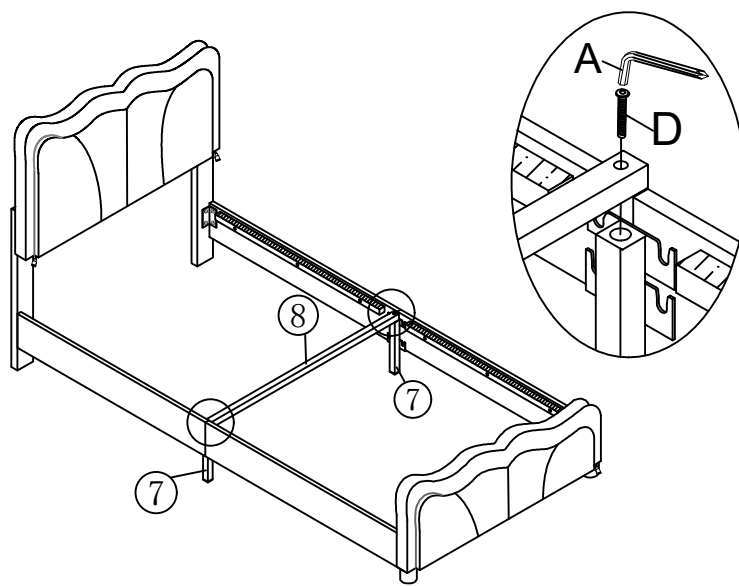

Step 6

A 	D  M8X40mm 2PCS
--	---



Step 7

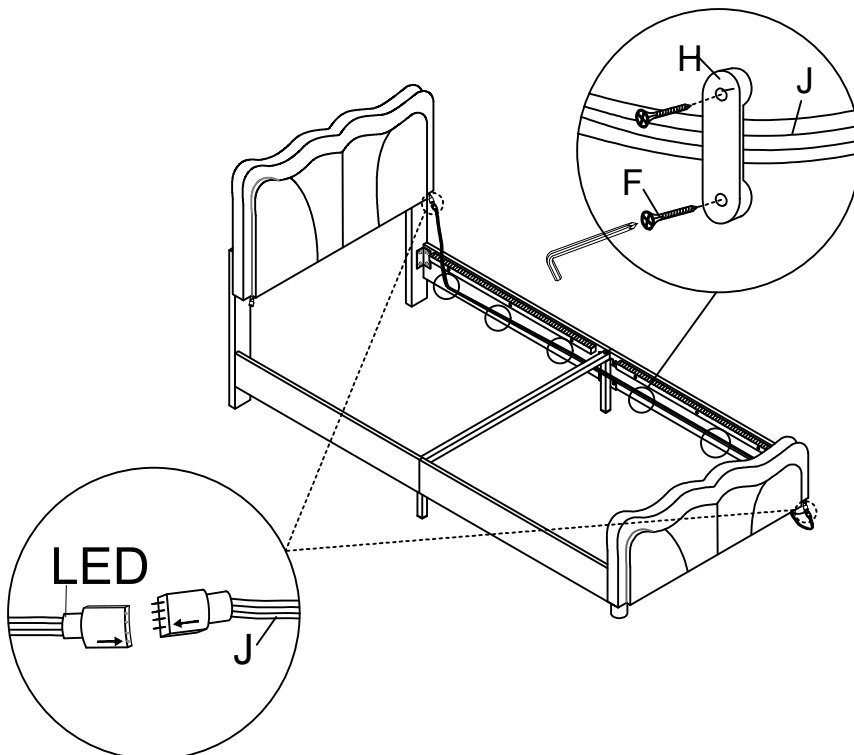

A	F	H	J
	 M3X16mm		
	10PCS	5PCS	1PC

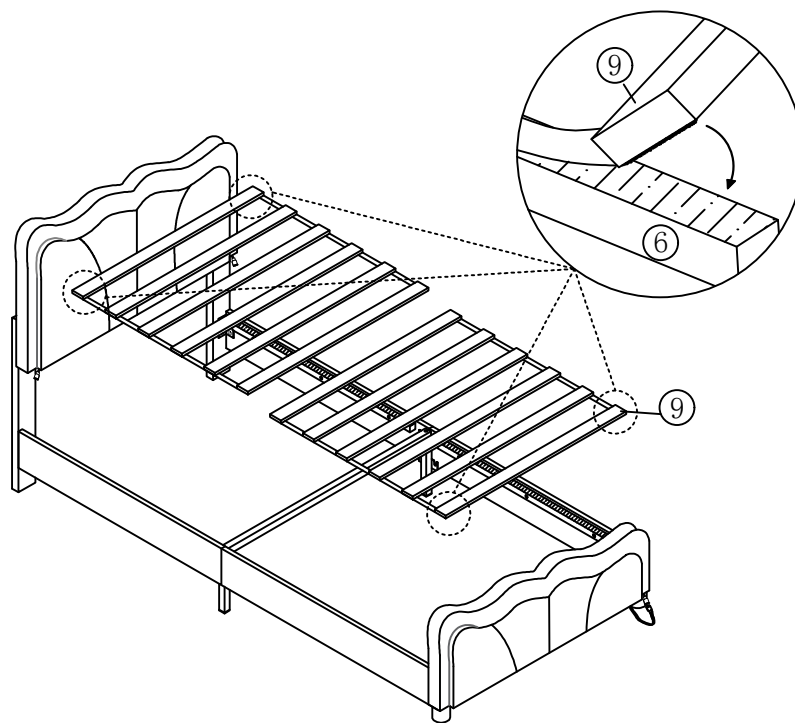

Step 8



Step 9

I	K
	
1PC	1PC

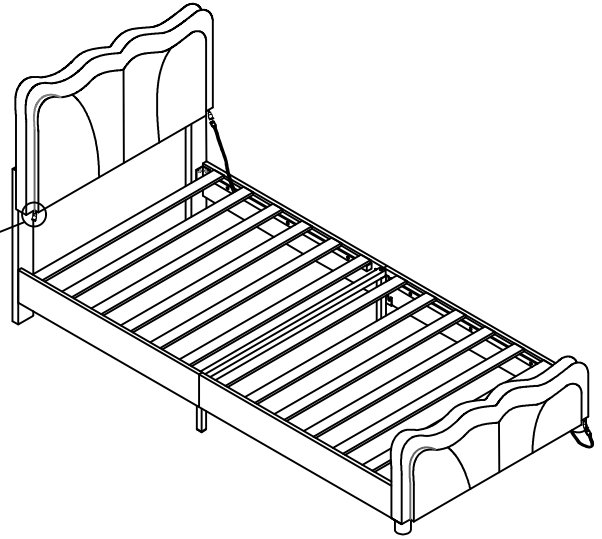
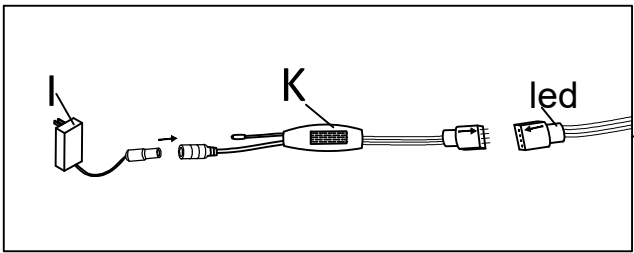

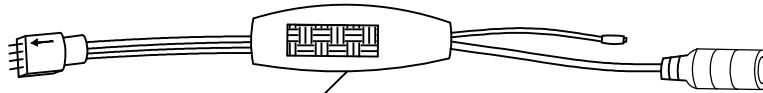

NOTICE:

You can scan the QR code here and download an app that can control the color of the light strip like a remote control. When your phone plays music through the app, the color of the light strip will also change according to the strength of the music.

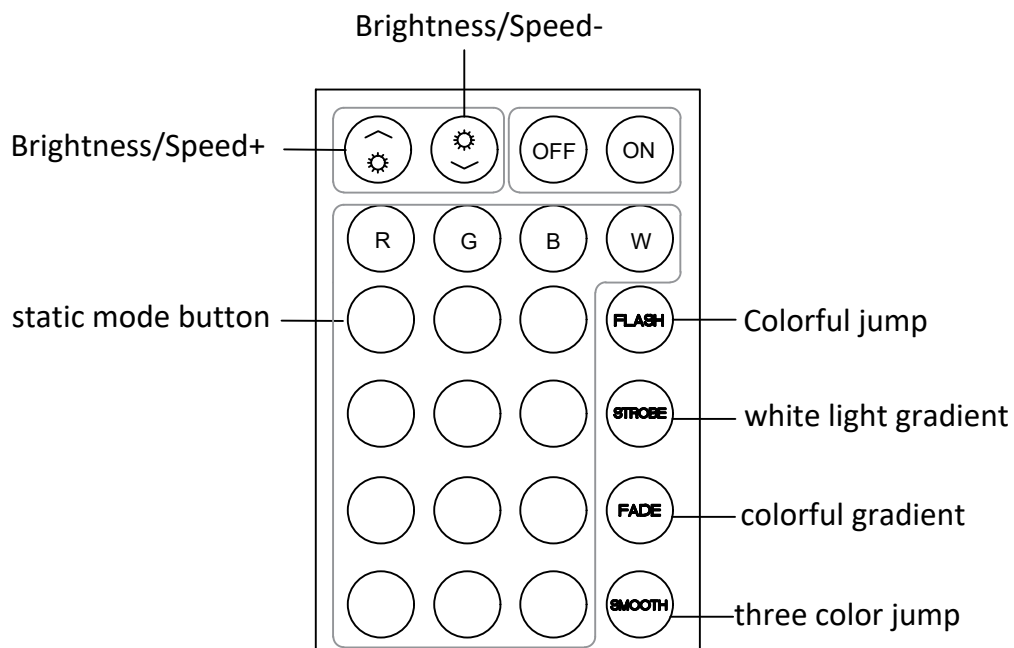

NOTICE:

When you use the remote control board to control the color of the light, Please remove the clear plastic card first, then please be sure to point the remote control at the color controller K.