

INSTRUCTION MANUAL

ONE-PIECE 4.8 L SINGLE FLUSH ROUND TOILET



Dear Customer,

Thank you for purchasing this product. To ensure best possible performance, please **READ, FOLLOW, AND KEEP THESE INSTRUCTIONS.**

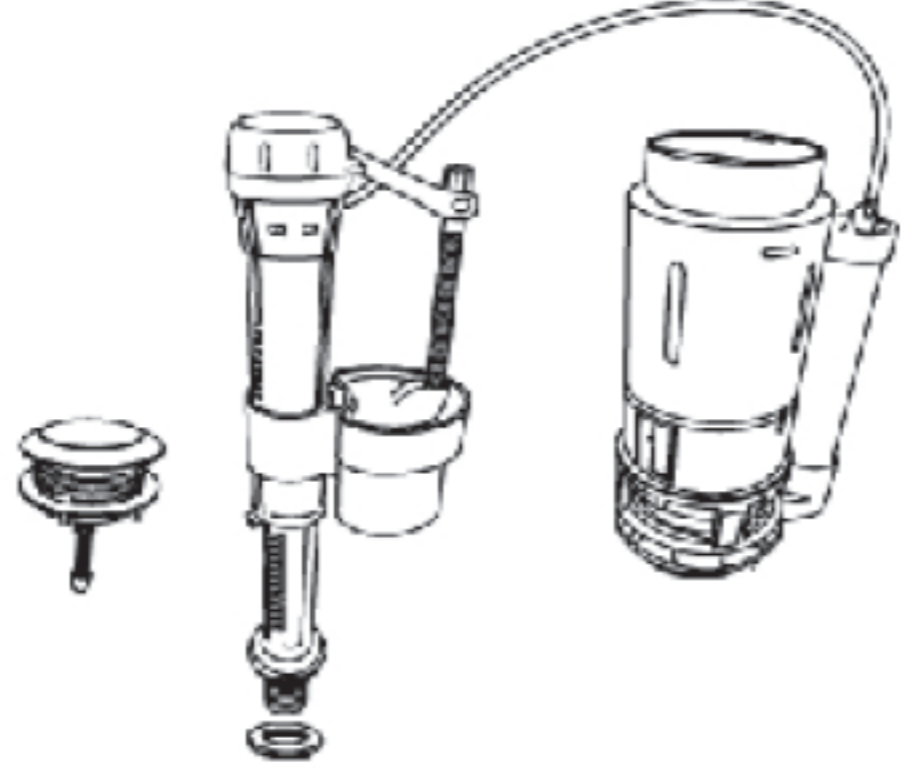

LIST OF PARTS

THE TOILET SHOULD INCLUDE THE FOLLOWING PARTS. PLEASE INSPECT BOX CONTENTS TO ENSURE YOU HAVE RECEIVED ALL PARTS.

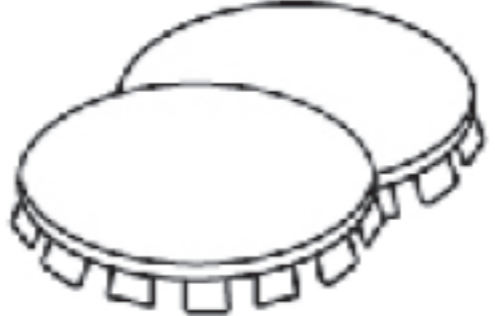
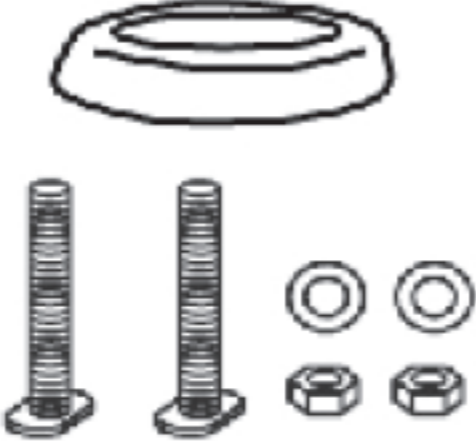
ITEM	DESCRIPTION	ITEM	DESCRIPTION
	1-piece toilet bowl		Tank trim
	Toilet seat		Cover caps
	Wax ring and flange bolts		

TOILET BOWL INSTALLATION PROCEDURE

STEP 1
Install bolts.

STEP 2
Attach wax ring.

STEP 3
Place bowl in position.

STEP 4
Install washers & nuts.
DO NOT OVERTIGHTEN!

STEP 5
Attach supply line. Supply line not included.
HAND TIGHTEN ONLY.

STEP 6
For maximum volume efficiency, adjust water level using adjustment rod. Attach cable to flush lever arm.

GENERAL INFORMATION

Flapper is secured by a rubber band. Cut it off to release flapper before flushing toilet. Adjust the water level (very important). For proper flushing of the bowl, the water must fill to the waterline mark indicated on the inside surface of the tank. The float rod and float ball control the water level. If the water level is below the waterline mark, turn the float rod adjusting screw counterclockwise. If the water is above the waterline mark, turn the screw clockwise. At least 20 PSI water pressure is necessary for proper functioning. If it is less than 20 PSI, the water may not be able to fill up to the waterline mark. However, the water pressure should not be more than 80 PSI.

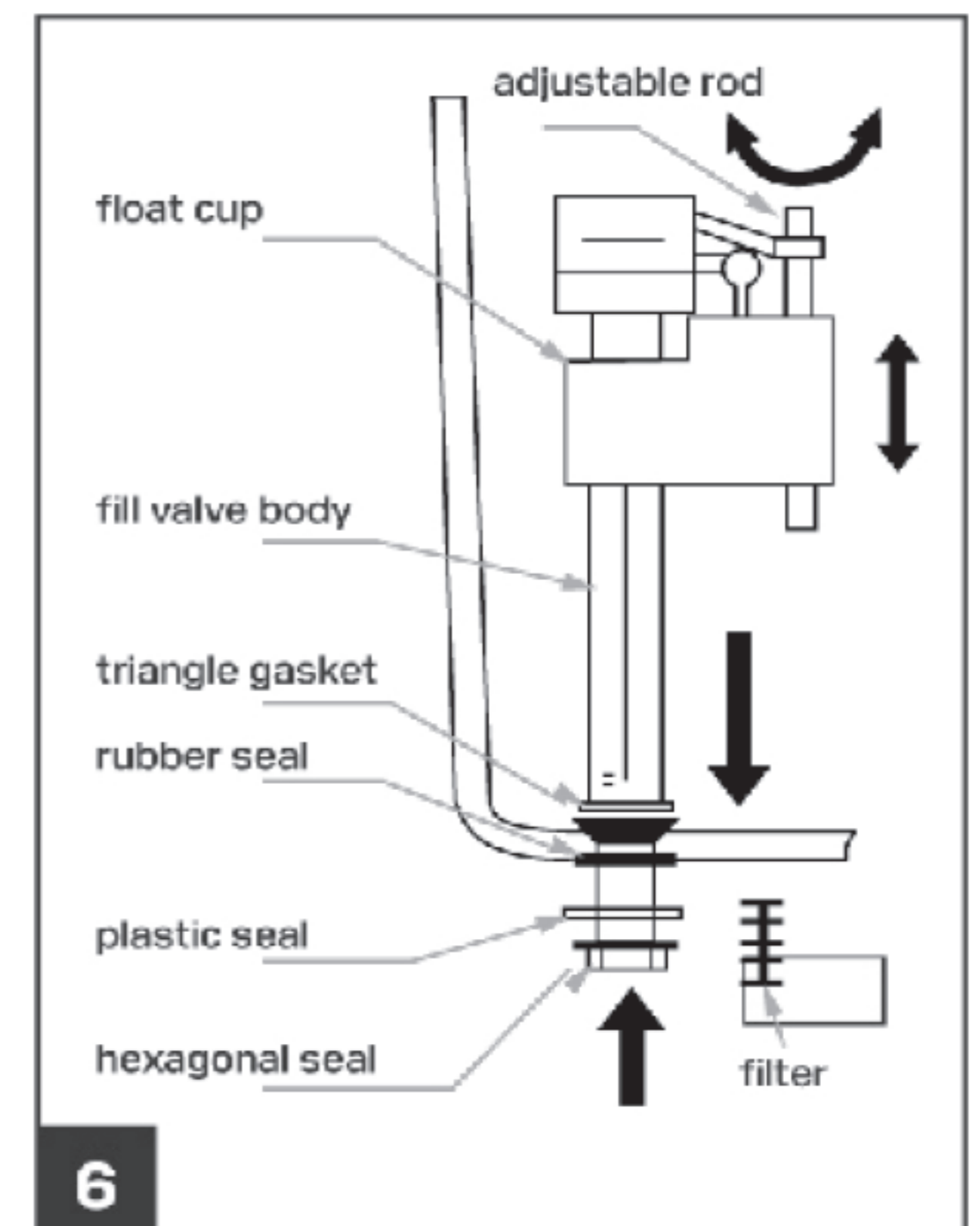
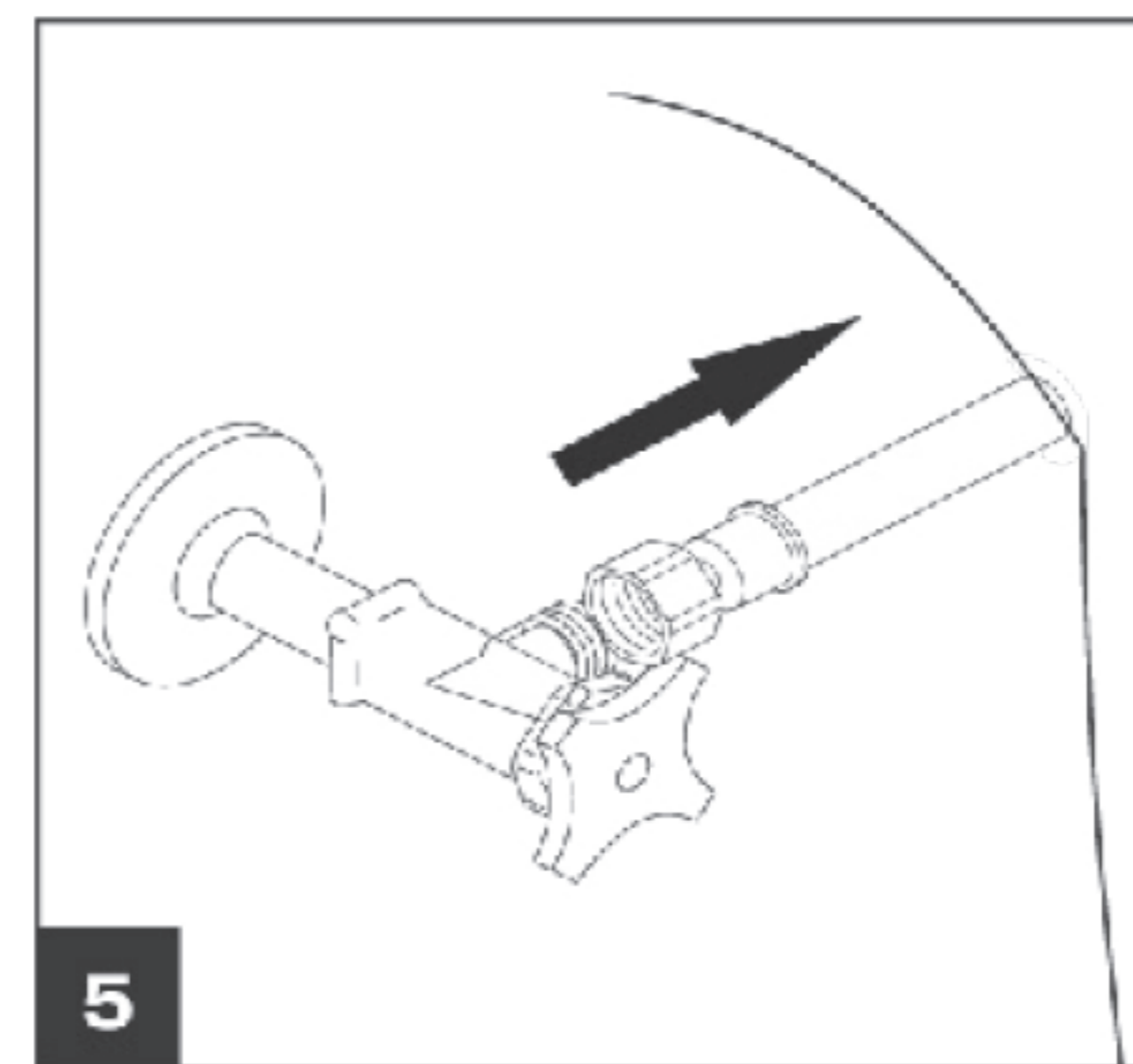
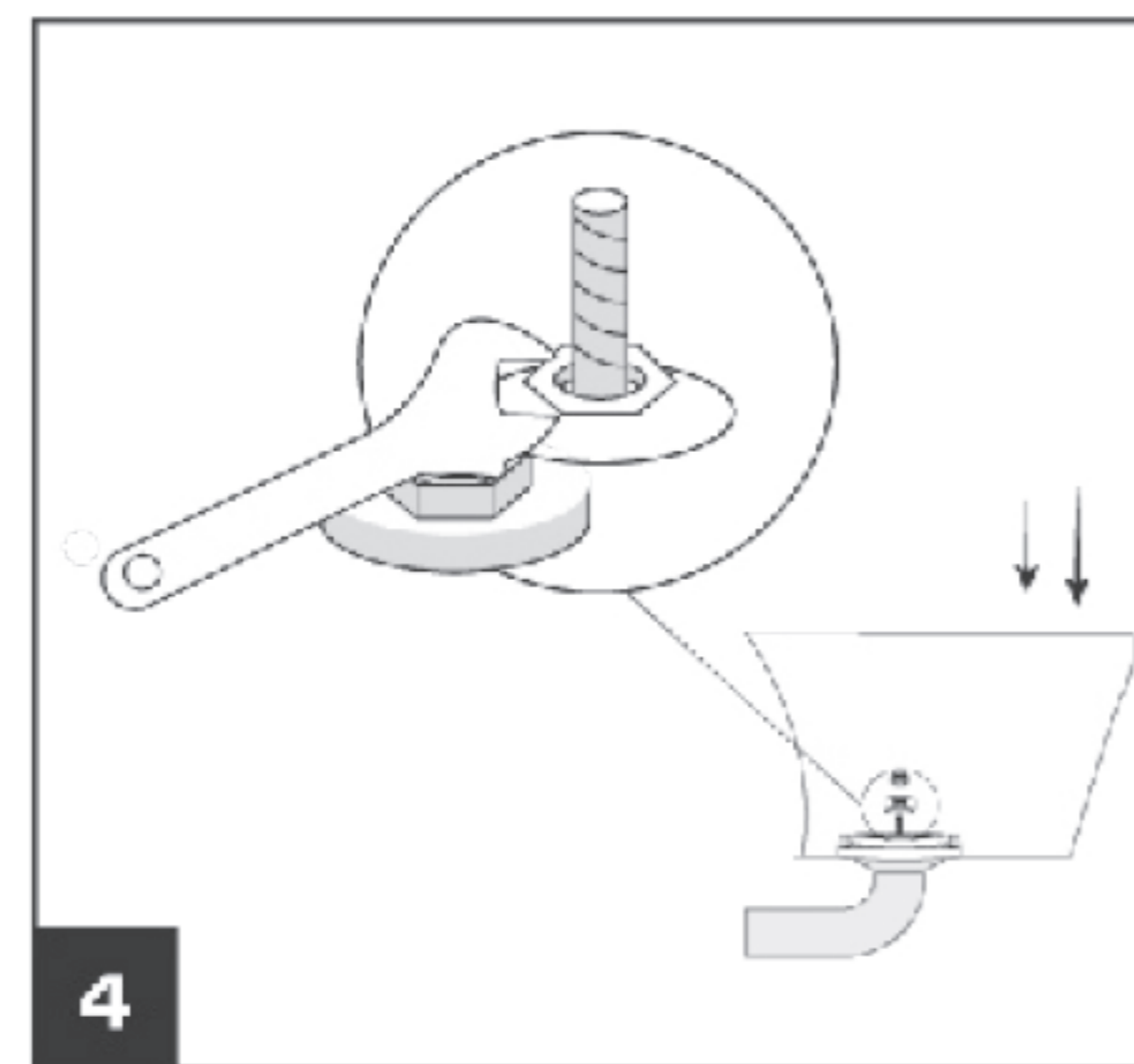
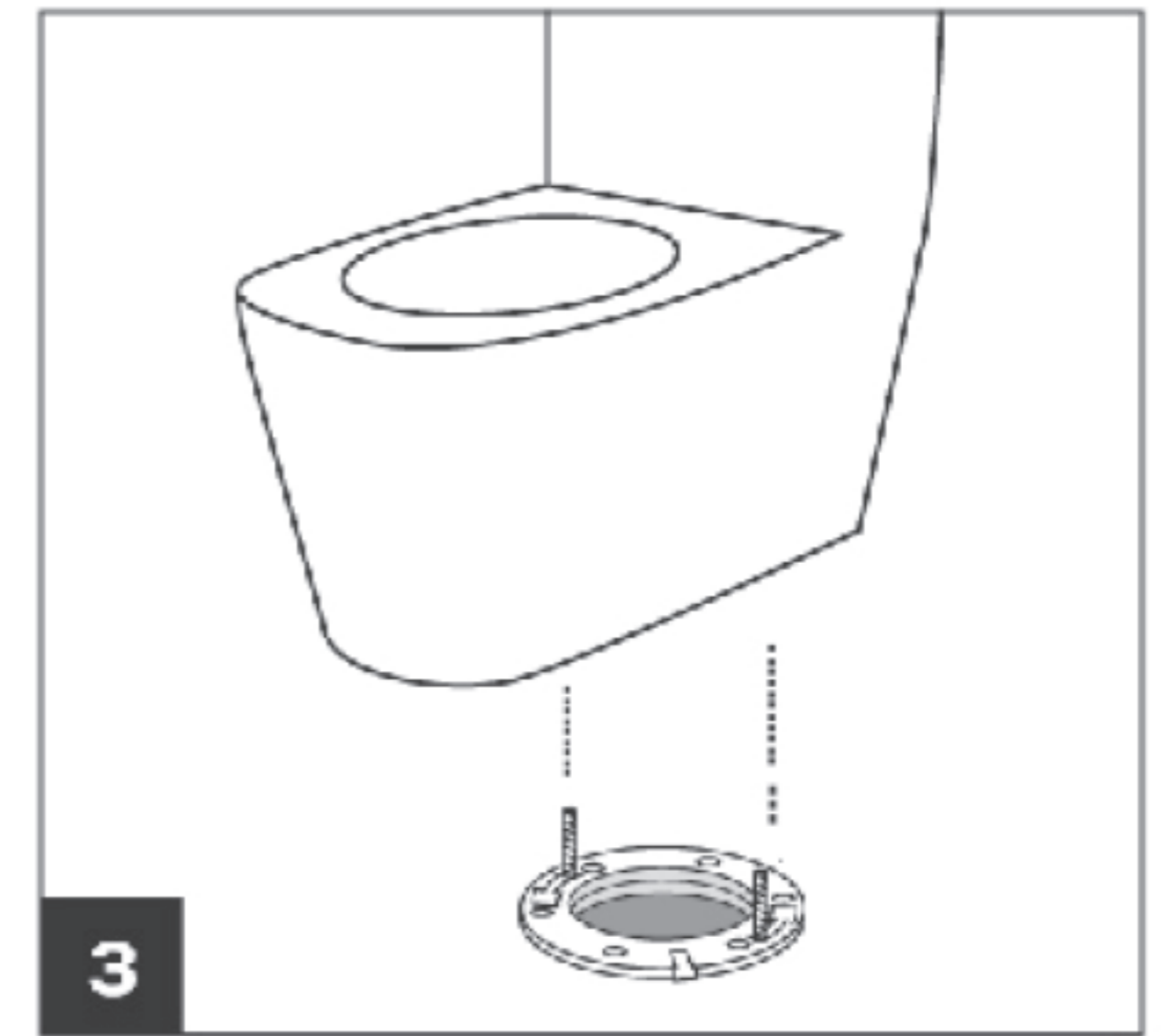
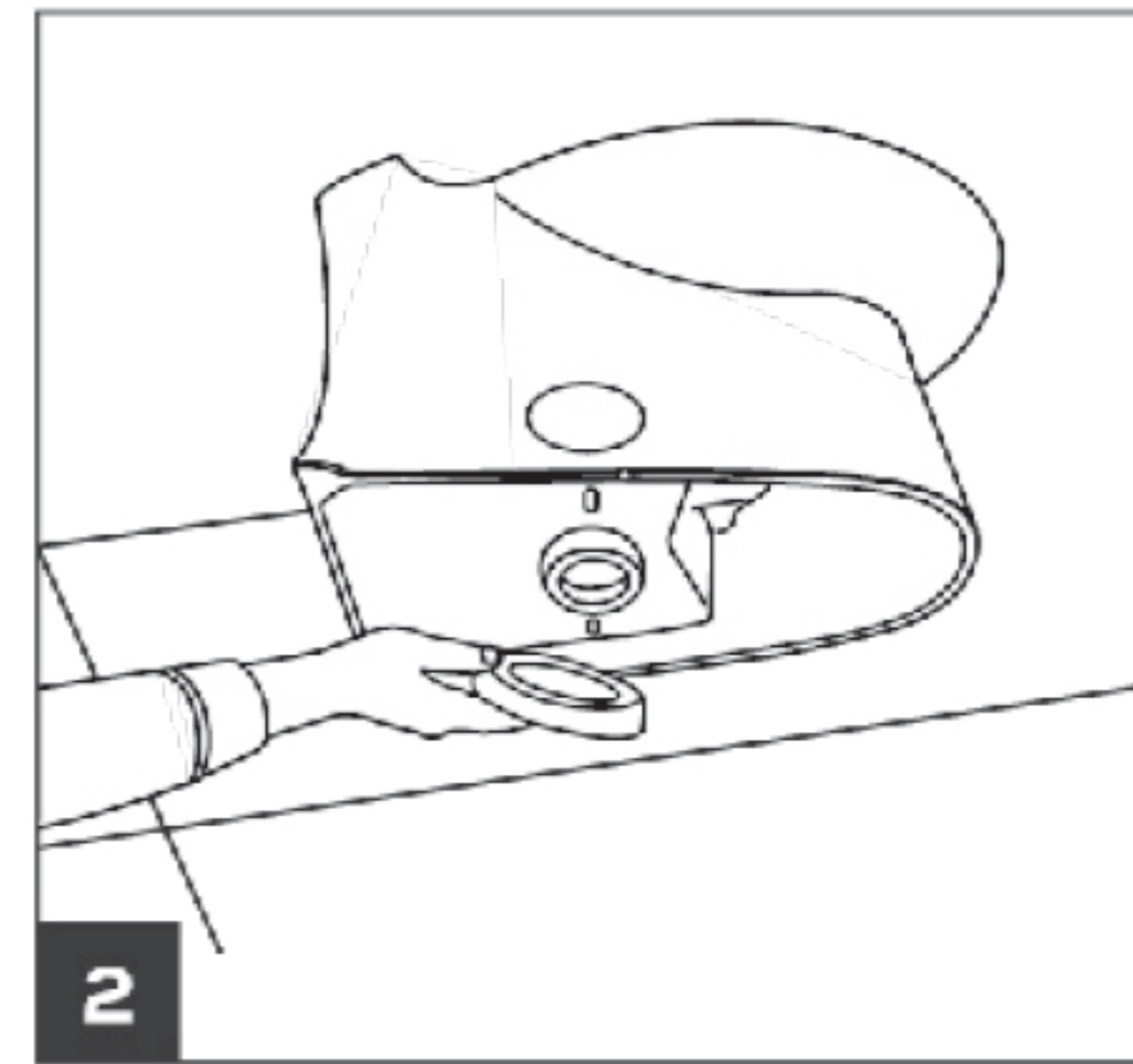
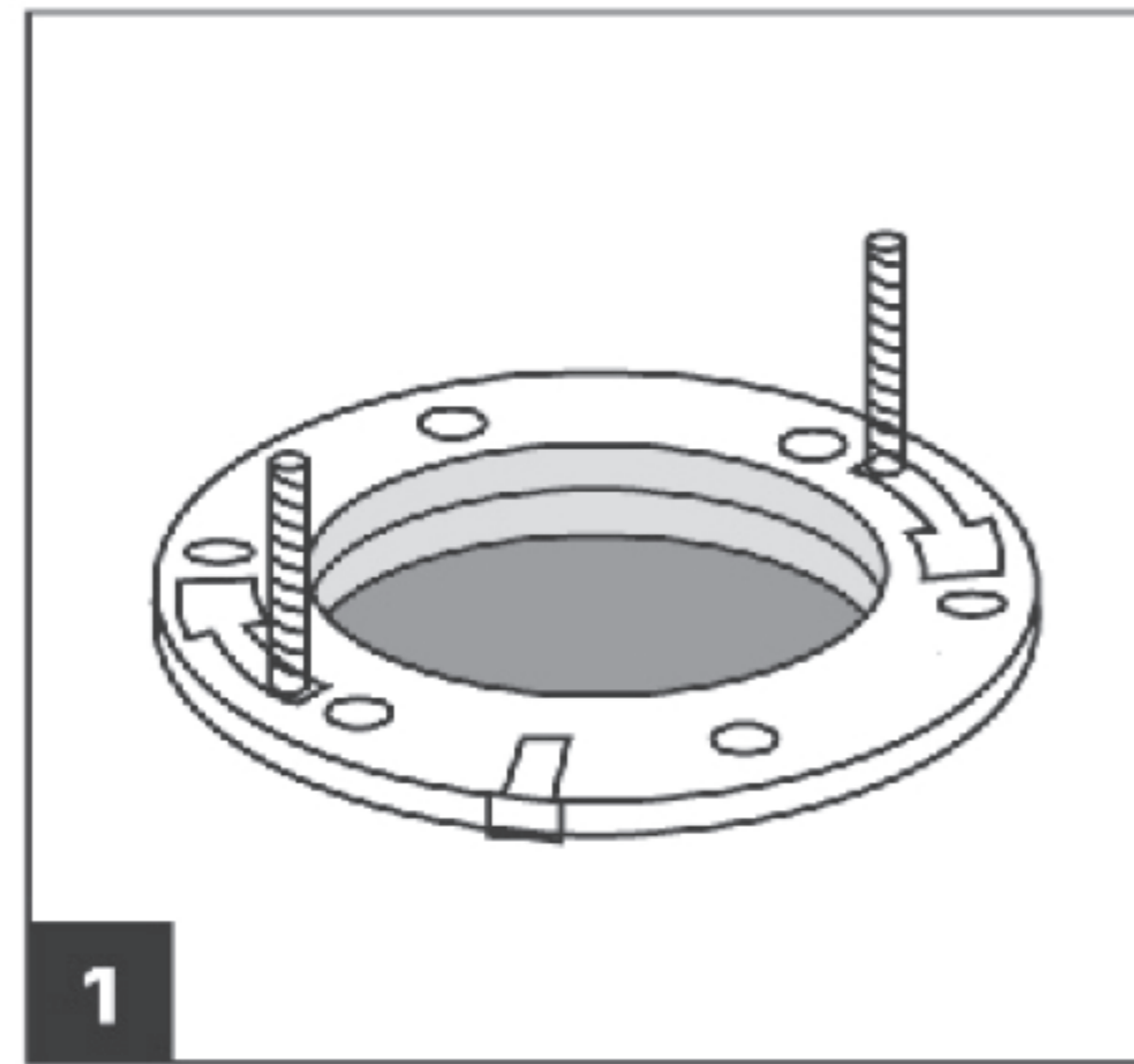

INSTRUCTION MANUAL

ONE-PIECE 4.8 L SINGLE FLUSH ROUND TOILET



TOILET SEAT INSTALLATION PROCEDURE

STEP 1

Flip out the seat cover hinge panel.

STEP 2

Place the panel onto the toilet as shown in photo.

STEP 3

Insert the screw, ensuring the holes are aligned.

STEP 4

Loosely tighten screw.

STEP 5

Adjust seat cover to the right position, then screw tightly.

STEP 6

Done.

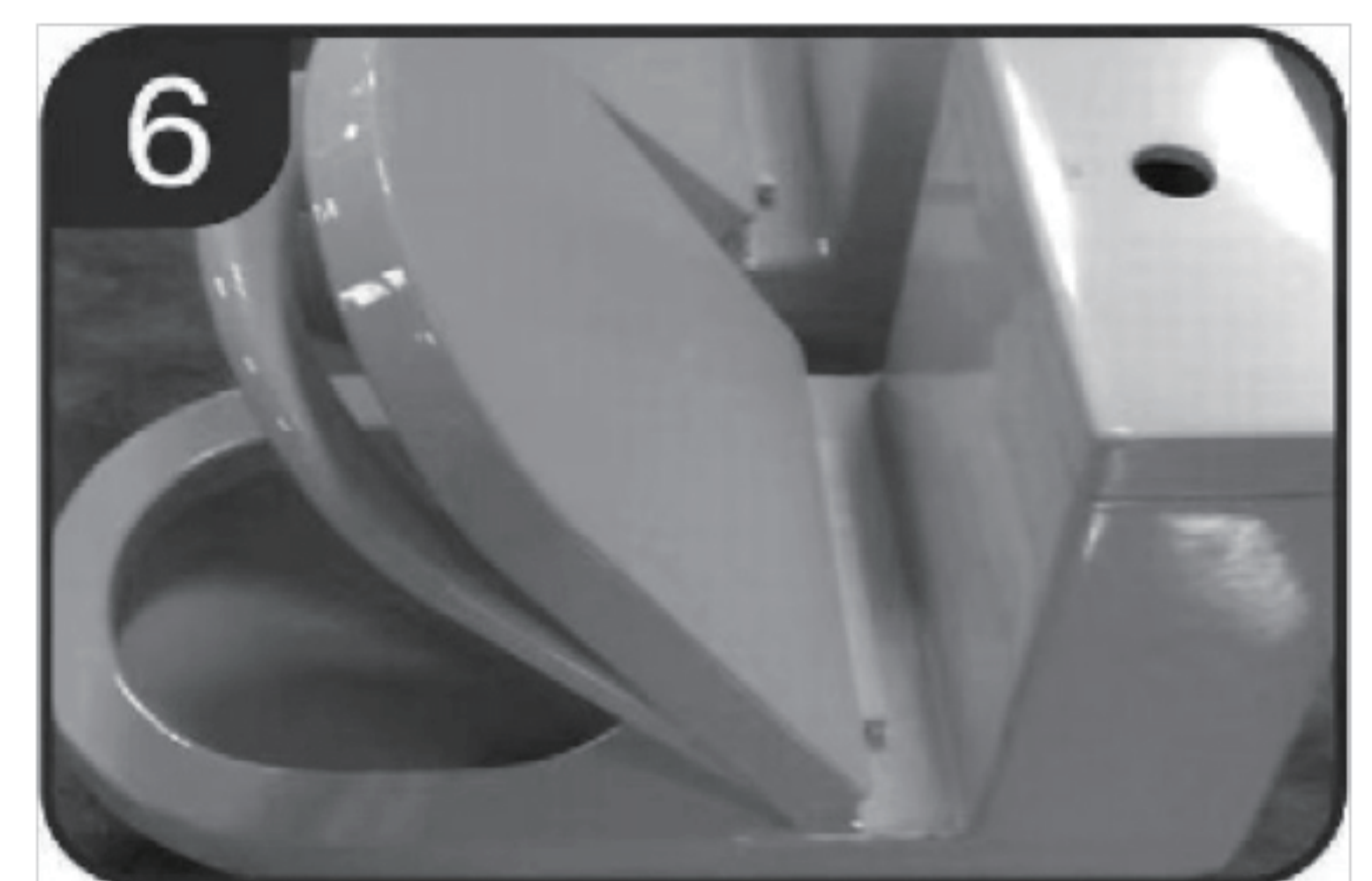
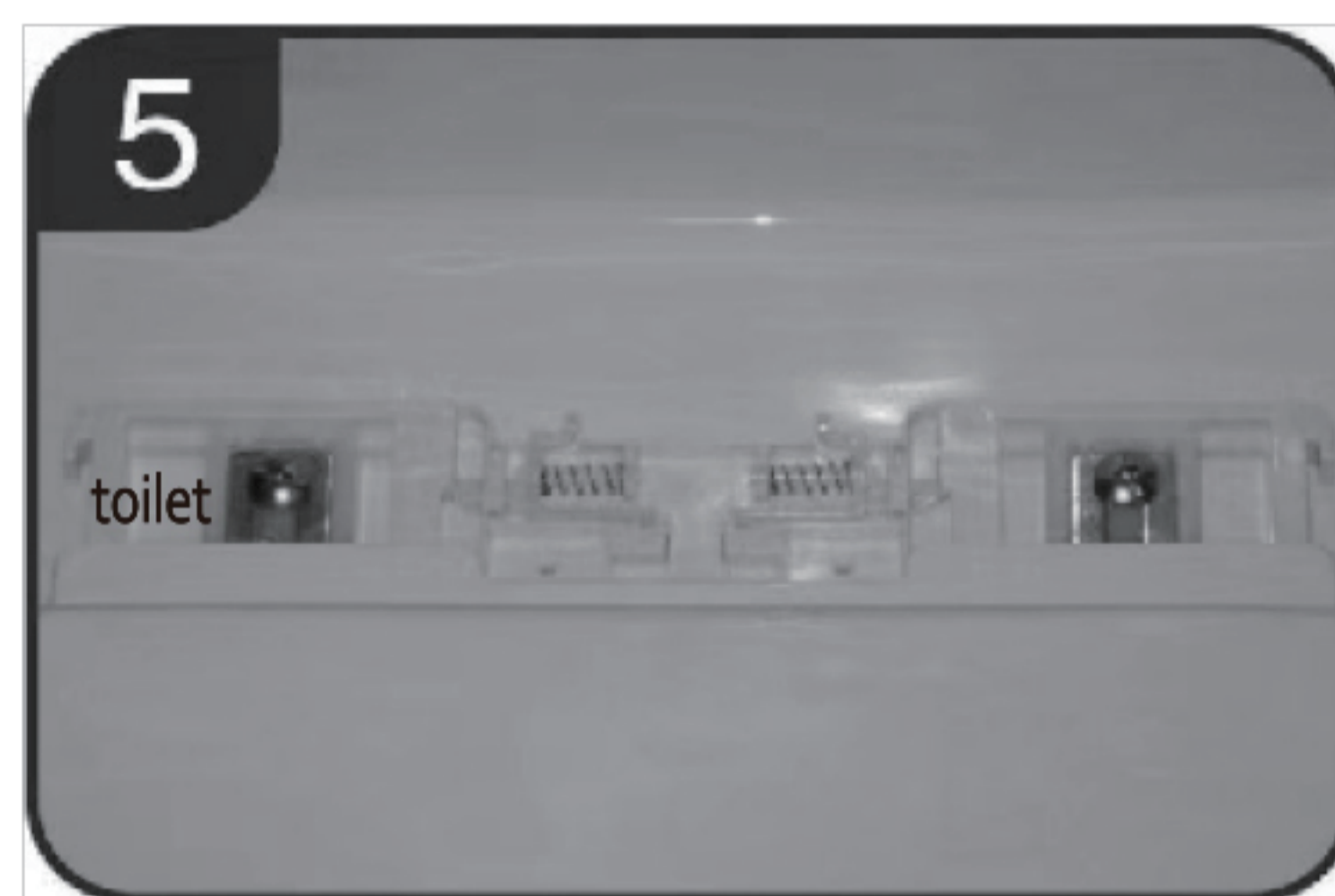
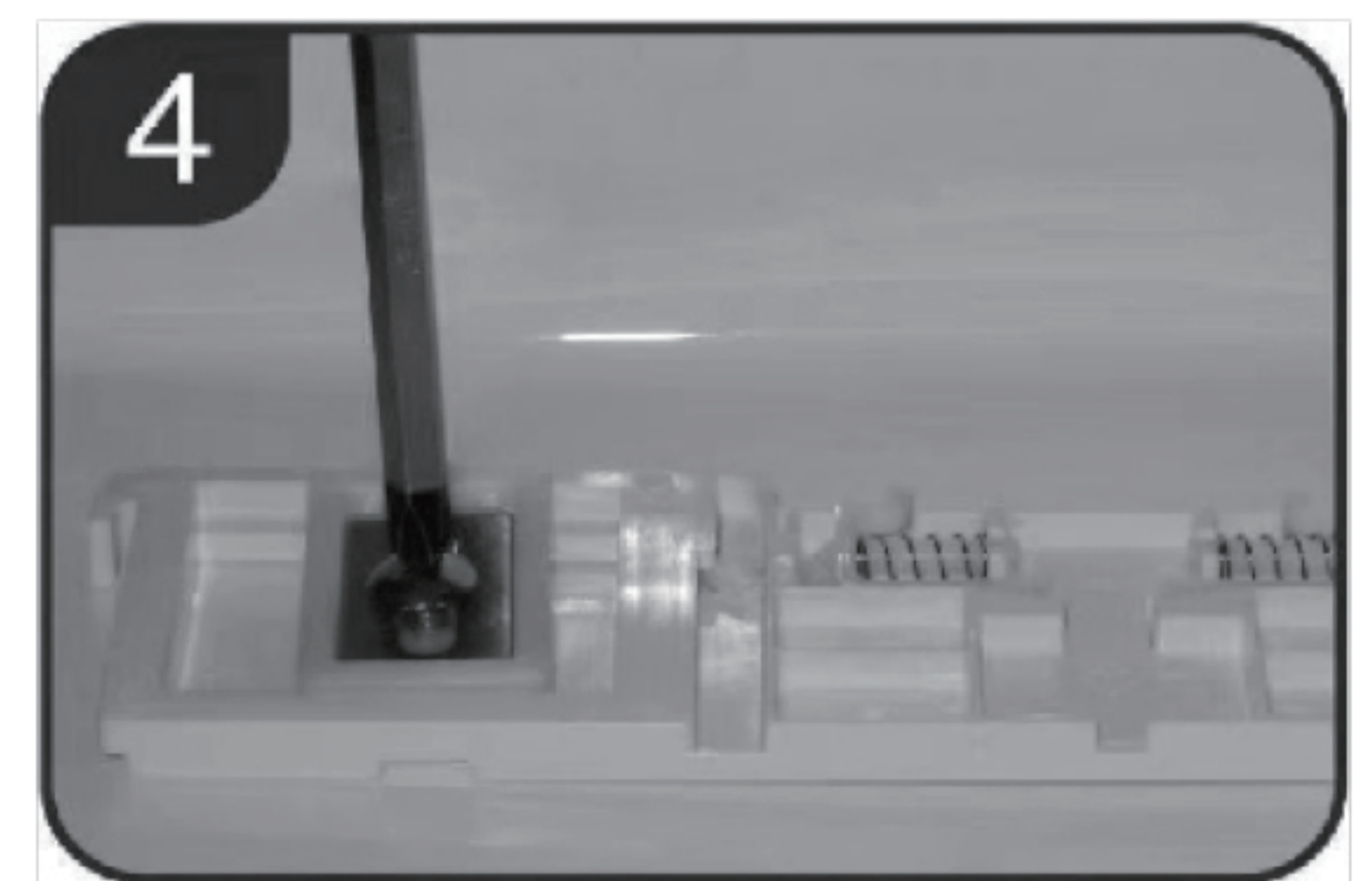

TROUBLESHOOTING

PROBLEM	REASON	SOLUTION
Fill valve can't fill	1. Fill switch is closed.	1. Turn on fill switch.
	2. Drain guard is stuck.	2. Clean drain guard.
	3. Float cup is crushed by tank wall.	3. Adjust direction of fill valve.
Leakage	1. Fit incorrectly.	1. Fit again according to the correct installation procedure.
	2. Flush valve seat does not fit flush valve body.	2. Fit again.
	3. Flush valve body is getting stuck.	3. Unhook and wash flush valve body.
	4. Incorrect operation.	4. Refill tube should be higher than water level.
Can't flush or flushes only a little	Steel wire is twisted or pulled too much.	Adjust flush valve body.
Half flush water level is too high or too low	Water level adjusted incorrectly.	Adjust water level.

CAUTION

We do not recommend the use of chemical commercial tank/bowl cleaners that are placed in the tank and remain there for extended periods of time.

These products may damage the ballcock and flapper valves and shorten the operating life of these parts.

The flapper and ballcock valves can be retightened if the water is leaking.

WARRANTY

Thank you for purchasing this toilet. These products have been made to demanding, high-quality standards and are 12 months guaranteed for domestic use against manufacturing faults. This warranty does not affect your statutory rights.

The toilet is guaranteed if used for normal trade purposes and is valid for the original buyer only. Any warranty is deemed invalid if the toilet has been improperly used or subject to neglect. The product is recommended for residential and non-commercial use. No warranty applies to commercial use. is not responsible for any costs related to labour, injuries or any other loss incurred during the product installation, repair or replacement, including any indirect or consequential damages. Due to continuous product improvement, we reserve the right to change the product specifications without prior notice.

A Message of Sincerity from Our Customer Service Team

Thank you for choosing CANEST products and services. We truly cherish every customer, and your satisfaction is our greatest aspiration.

If you encounter any issues during use or have any questions about our products and services, please don't hesitate to reach out to us at any time. We are committed to providing you with professional and efficient assistance to ensure you have a pleasant experience.

Contact Information

- Customer Support Email: service@canesthome.com
- Customer Service Hotline: 1-702-824-3195

Our Commitments

1. Prompt Response: We will reply to and address your inquiries within 24 hours.
2. Dedicated Assistance: No matter the size of the issue, we will listen carefully and work to find a satisfactory solution.
3. Continuous Improvement: We value every piece of feedback and strive to continuously improve our products and services to provide you with a better experience.

Once again, thank you for your trust and support! If you are satisfied with our products and services, we'd greatly appreciate it if you could share your experience with others. Your encouragement is our greatest motivation!

Wishing you a wonderful day!

Sincerely,
CANEST Customer Support Team