

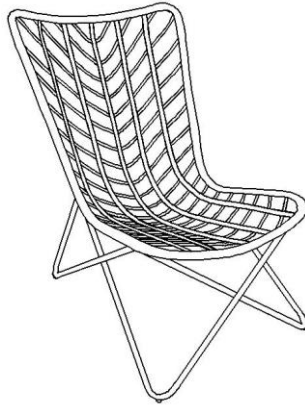



# Assembly Instructions

Caution: You must read this before you proceed.



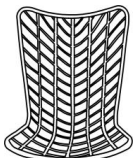

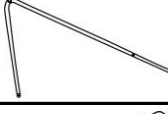
## Chair



## Parts List

Label	Picture	Description	QTY
A		Seat	1
B		Left Front Leg	1
C		Right Front Leg	1
D		Left Back Leg	1
E		Right Back Leg	1

## Hardware

Label	Picture	Description	QTY
①		Allen Wrench	1
②		Bolt (M6x25MM)	5
③		Bolt (M6x13MM)	9
④		Washer (M6*14*1MM )	14

# Assembly Preparation

## Before Beginning Assembly:

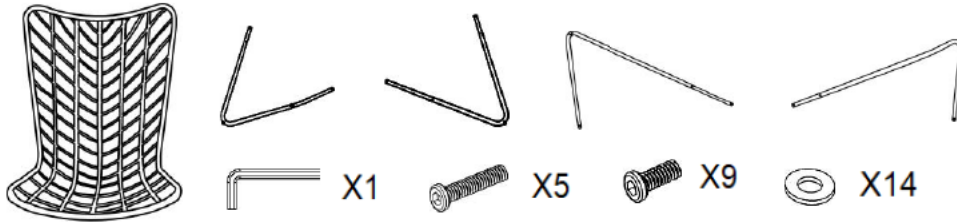

- Read instructions, cover to cover-
- Have 2 adults on hand for assembly-
- Do not assemble on flooring or carpet-
- Assemble on a clean non-marring surface (packing foam)-
- Save all packaging until finished-

# Assembly Steps

## Overview

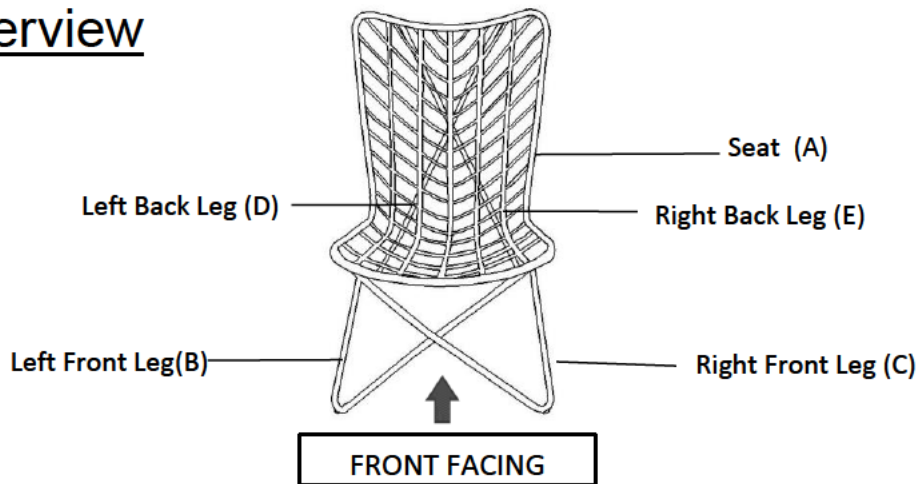

This Chair has multiple parts and may require up to some 30 minutes to assemble. To give you an overview of the Chair parts, the above picture is to help you put the various parts into perspective. Please read through the instructions below to familiarise yourself with the parts and steps before assembly.

## Step 1

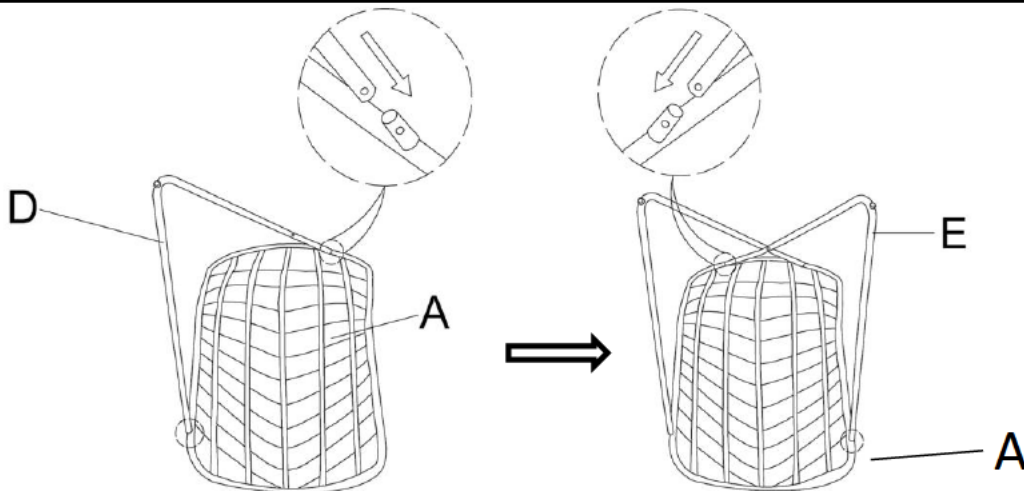

Open the carton and place all the parts onto a clean, non-marring surface. Please insert the Left Back Leg (D) into the Seat (A), then insert the Right Back Leg (E) into the Seat (A) as shown in the picture.

## Step 2

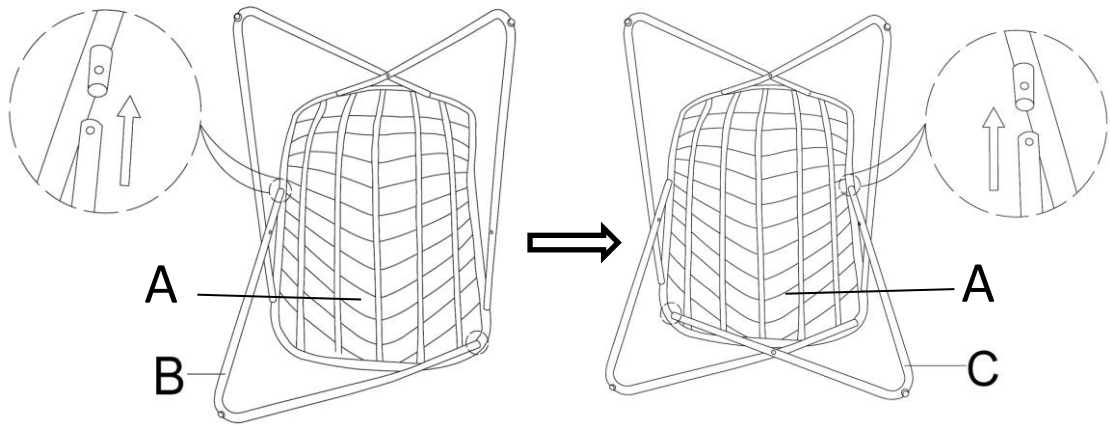

In the same way, insert the Left Front Leg (B) into the Seat (A), then insert the Right Front Leg (C) into the Seat (A) as shown in the picture.

## Step 3

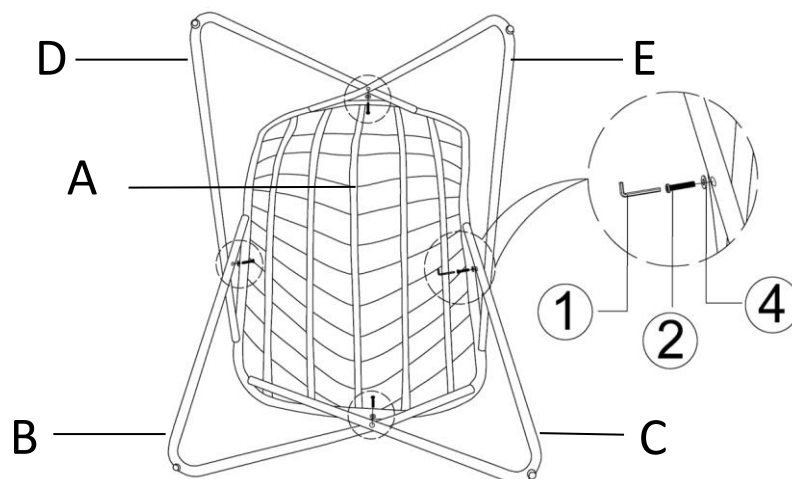

Attach the Left Front Leg (B) and the Right Front Leg (C) together, and the Left Back Leg (D) and the Right Back Leg (E) together using Bolts (②) and Washers (④) with the Allen Wrench (①);

Then attach the Left Front Leg (B) and the Left Back Leg (D) together, and attach the Right Front Leg (C) and the Right Back Leg (E) together using Bolts (②) and Washers (④) with the Allen Wrench (①) as shown in the picture.

**Do not fully tighten the bolts at this time.**

## Step 4

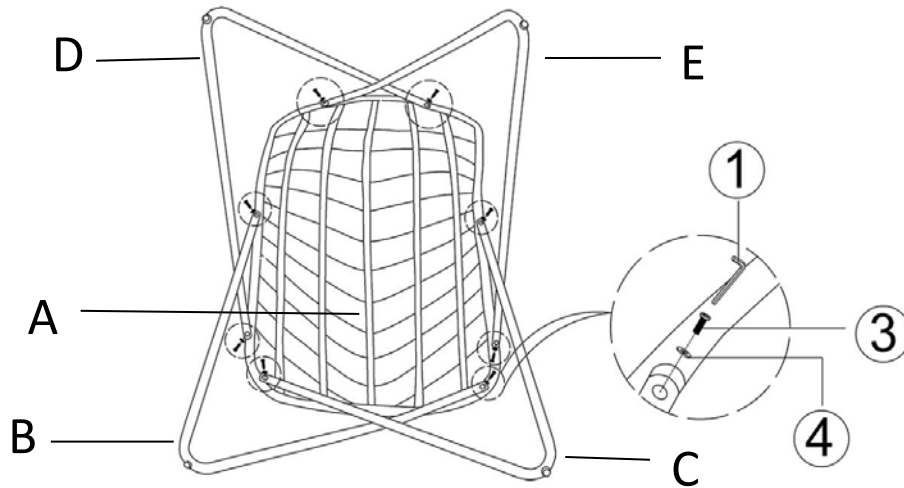

Attach the Left Back Leg (D), the Right Back Leg (E), the Left Front Leg (B), the Right Front Leg (C) to the Seat (A) respectively, using Bolts (3) and Washers (4) with the Allen Wrench (1) as shown in the picture.

**Do not fully tighten the bolts at this time.**

## Step 5

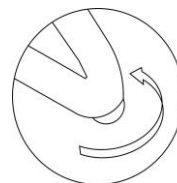
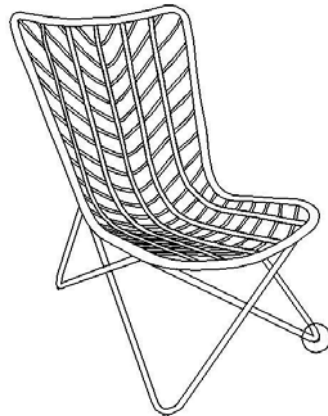

Adjust Pre-installed  
Levellers height for  
balance











Tighten all Bolts in a sequential manner. Place the Chair on a **LEVEL SURFACE** to check for wobbles.

If it wobbles, adjust the Legs' Pre-installed Levellers until the Chair is level with the ground.

**Your Chair is ready for use.**

**This Chair can only be used on a flat, level surface.**

## Care & Maintenance

- ⊘  ● Prolonged exposure to rain may cause rusting which can stain floors.
- ⊘  ● Do not put hot items directly on furniture surface.
- ⊘  ● Do not clean furniture with harsh cleansers or polish.
- ✓  ● To obtain the longest lifespan of your outdoor products, minimizing exposure to direct sunlight is recommended.
- ⊘  ● Children should not climb or jump on the furniture.
- ⊘  ● Do not write on furniture without a padded barrier to protect the surface.
- ✓  ● To obtain the longest lifespan of your outdoor products, avoid extended and lengthy exposure to rain, snow, and direct sunshine. Whenever possible cover the product and /or place under patio or awnings.
- ⊘  ● Not for commercial use. For residential use only.
- ⊘  ● Stains may be removed with mild soap solution and damp cloth.
- ✓  ● Keep away from sources of ignition.
- ✓  ● Dust and pick-up spills using a clean, non-colored, lint-free cloth.