











CARE AND MAINTENANCE

Wipe clean with a soft, dry cloth. The seat board can be cleaned with a mild cleaner. Test the cleaning method on a hidden area before using them over the entire area.

NOTICE

- * Please make sure that you have all parts indicated before you begin assembly of this item.
- * This item should be assembled on a soft surface to prevent scratching the finished product during assembly.
- * This item may require periodic tightening.
- * Do not tighten bolts until completely assembled.

Part List and Hardware List

PIECE	DESCRIPTION	PICTURE	QUANTITY
A	Side Frame (Left)		1 X
B	Side Frame (Right)		1 X
C	Upper Stretcher		2 X
D	Bottom Stretcher		3 X
E	Seat Cushion		1 X
F	Pillow		1 X
H1	Allen Bolt	 1/4"x5/8"	20 X
H2	Allen Bolt	 5/16"x2"	4X
H3	Allen Key	 M4	1 X
H4	Allen Key	 M5	1 X

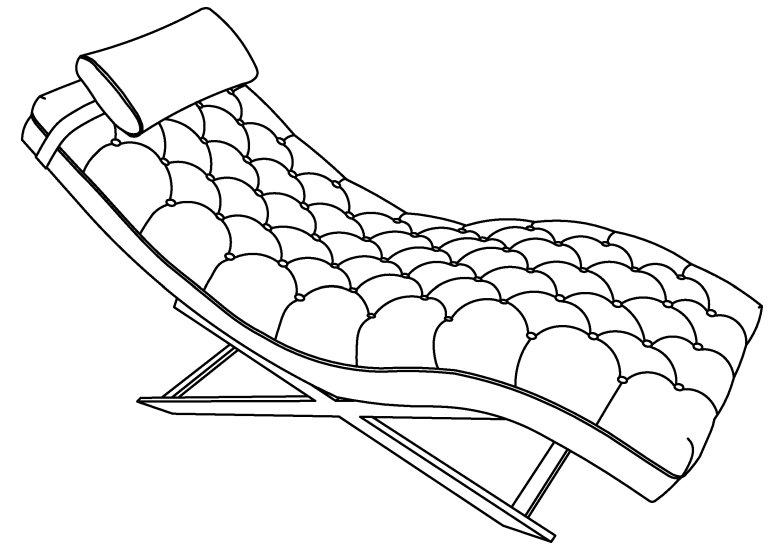

PREPARATION

Before beginning assembly of product, make sure all parts are present. Compare parts with package contents list and hardware contents list. If any part is missing or damaged, do not attempt to assemble the product.

Estimated Assembly Time:30 minutes.

Tools Required for Assembly (included):Allen Key.

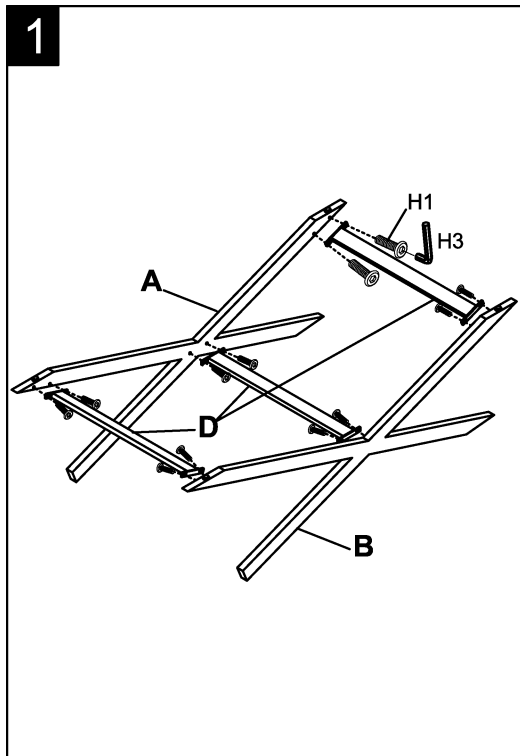

Step 1

Attach 3*Bottom Stretchers (D) to both Side Frames (A & B). Insert 12*Allen Bolts (H1) as pictured with Allen key (H3). Please make sure to half tighten.

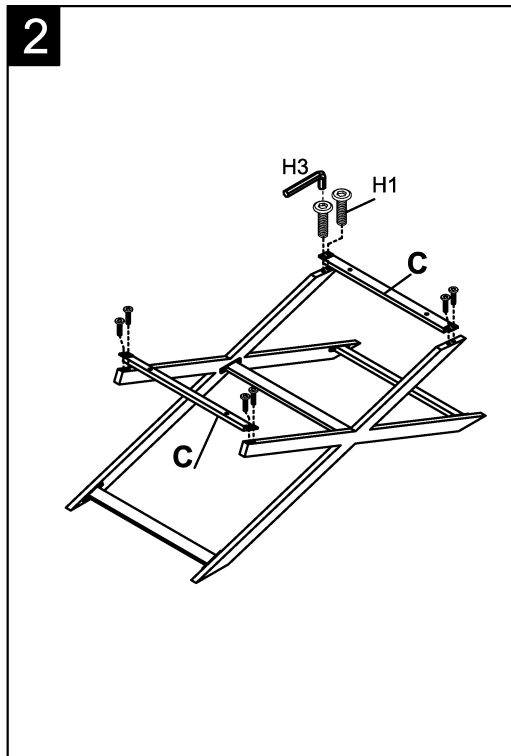

Step 2

Attach 2*Upper Stretchers (C) to both Sides (A & B). Insert 8*Allen bolts (H1) with Allen key (H3). Fully tighten these bolts only.

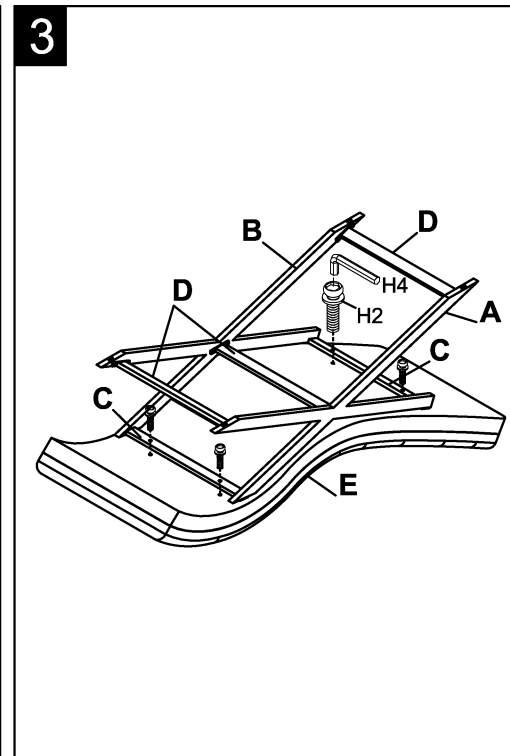

Step 3

Flip the assembled metal based around. Then assemble it to the back side of the Seat Cushion (E). Use Allen key (H4) to lock through holes on both Upper Stretchers (C) with 4*Allen Bolts (H2).

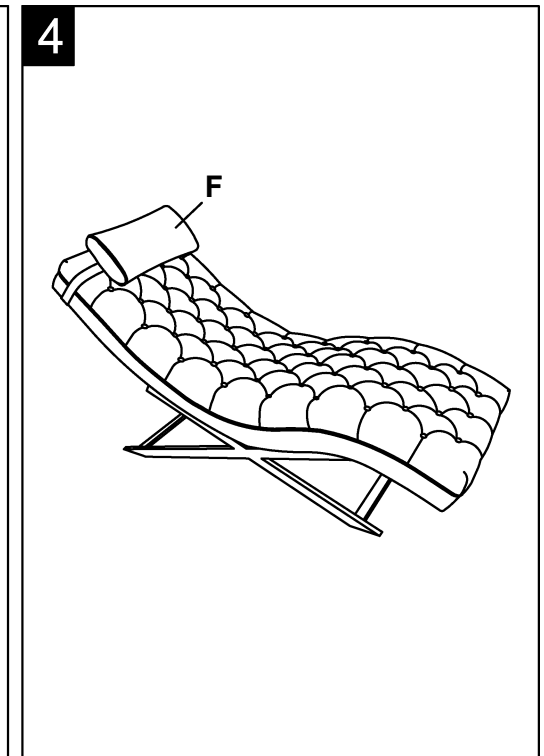

Step 4

Flip the seat upright and then fully tighten all bolts. Place Pillow (F) on the top front of the Seat Cushion (E). Fasten pillow with Velcro strap underneath the cushion seat as pictured.