

Assembly Instructions

Storage Bench

Important safety instructions:

- Thanks for your purchasing this product, please read carefully instruction before assembly.

- For your safety and ease, assembly by two or more adults is recommended.

Keep instructions for future use.



Pre-assembly:

- Do not discard any content until assembly is complete to avoid accident tally discarding parts or hardware.

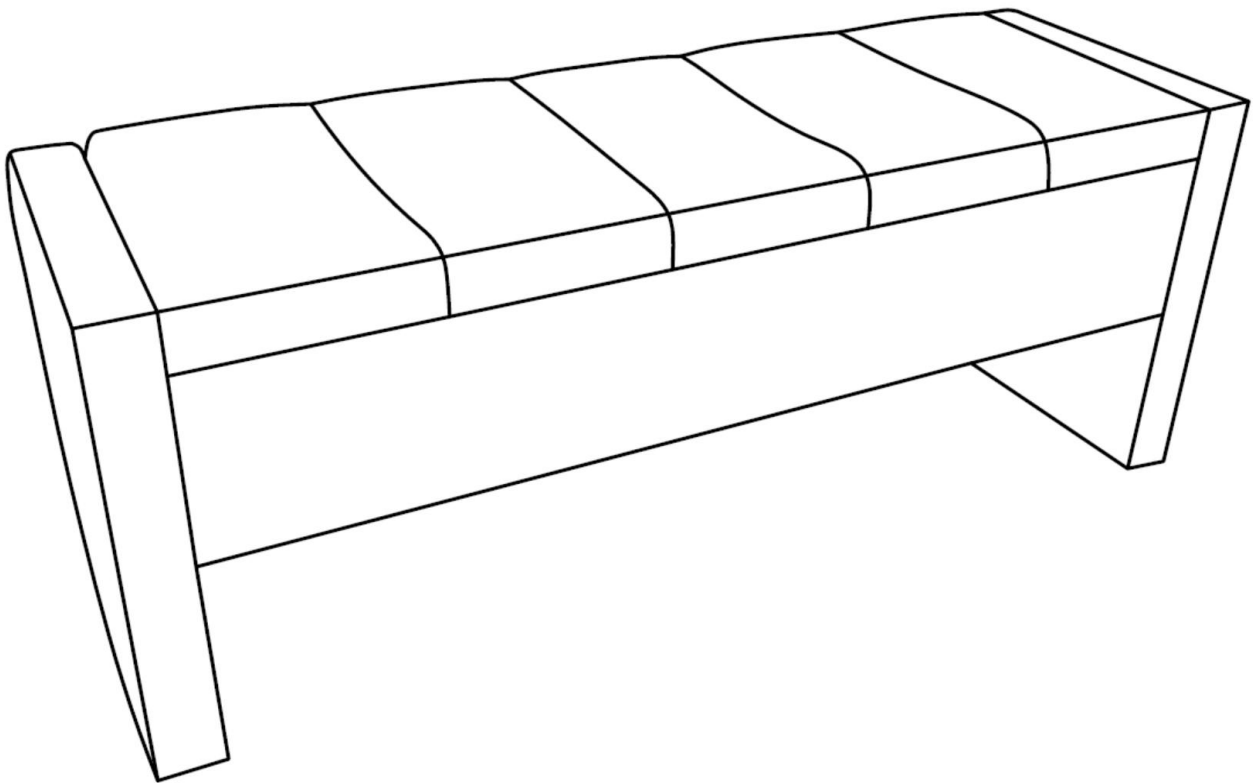
- Take out all parts and hardware from box and place them on a clean, soft and smooth surface.

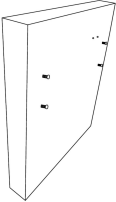
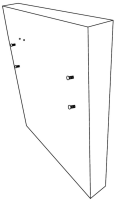
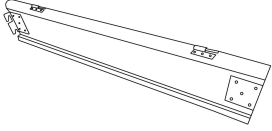
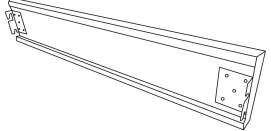
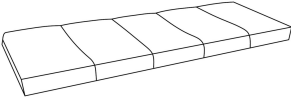
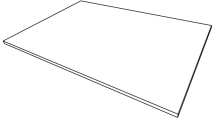
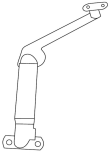
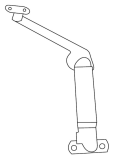

Parts List

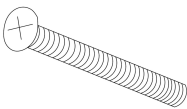
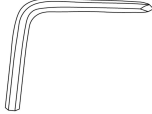
Ax1 	Bx1 	Cx1 	Dx1 
LEFT ARM	RIGHT ARM	BACK PANEL	FRONT PANEL
Ex1 	Fx2 	Gx1 	Hx1 
BENCH TOP	BASEPLATE	LEFT HINGE (Labeled 'LEFT')	RIGHT HINGE (Labeled 'RIGHT')
Ix8 	Jx8 	Kx1 	
Bolts M8*30mm(Already assembled on arms)	Bolts M4*30mm	ALLEN WRENCH	

OVERVIEW:

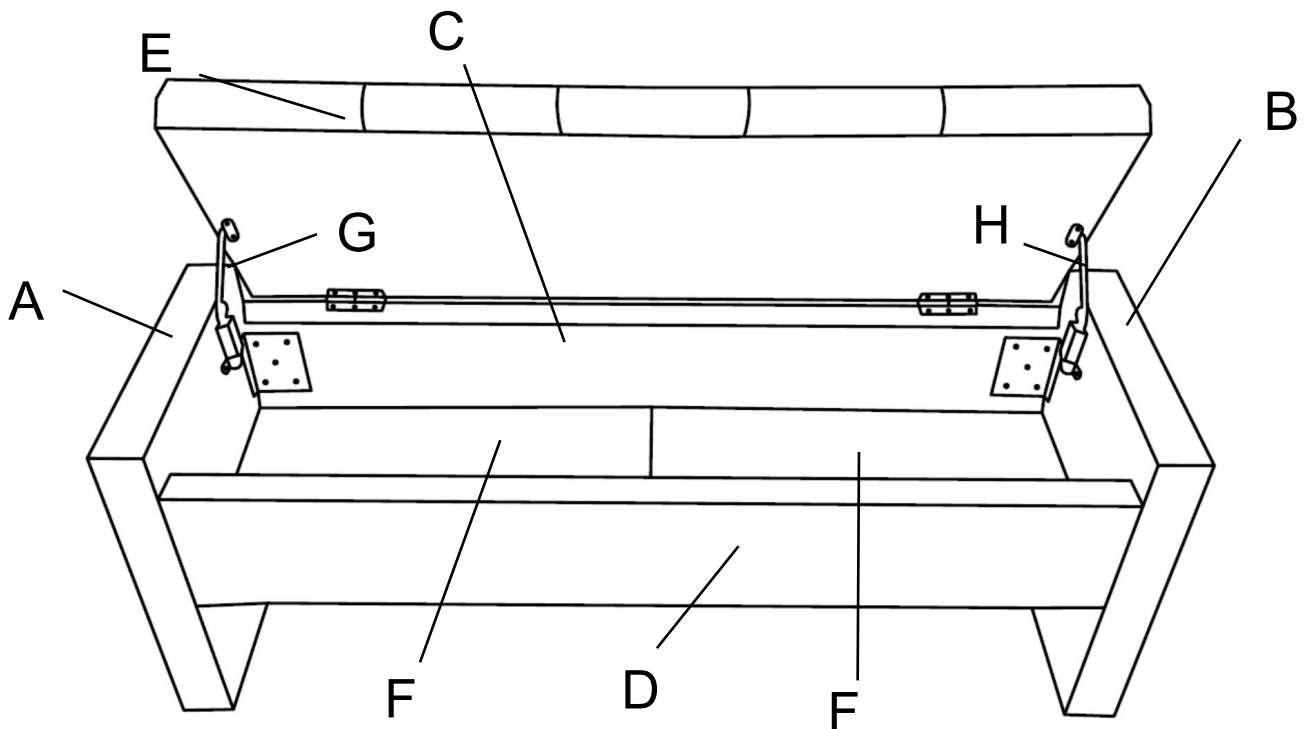

Assembly Steps:

Step 1: Rotate counterclockwise the **Bolt(I)** assembled on **Left Arm(A)** and **Right Arm(B)** of about 15mm out with **Allen Wrench(K)** if necessary.

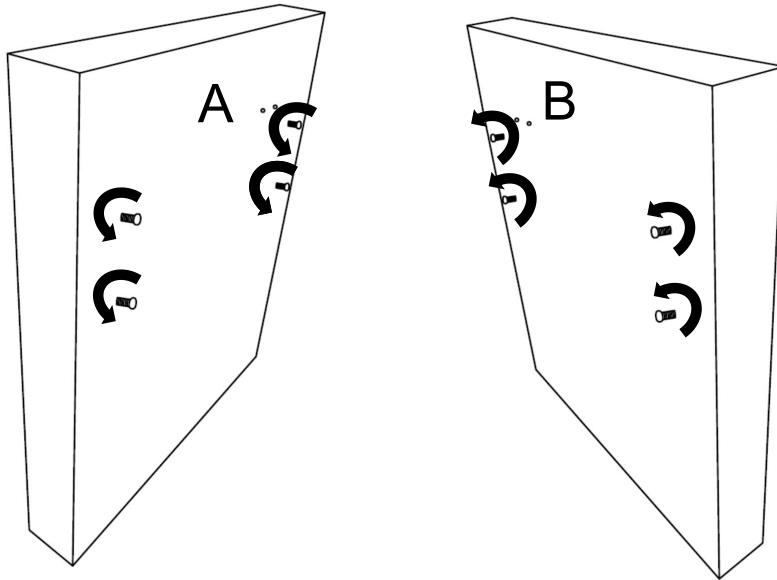

Step 2: Connect the **Back Panel(C)/Front Panel(D)** and **Left Arm(A)/Right Arm(B)** together and then secured with **Allen wrench(K)**

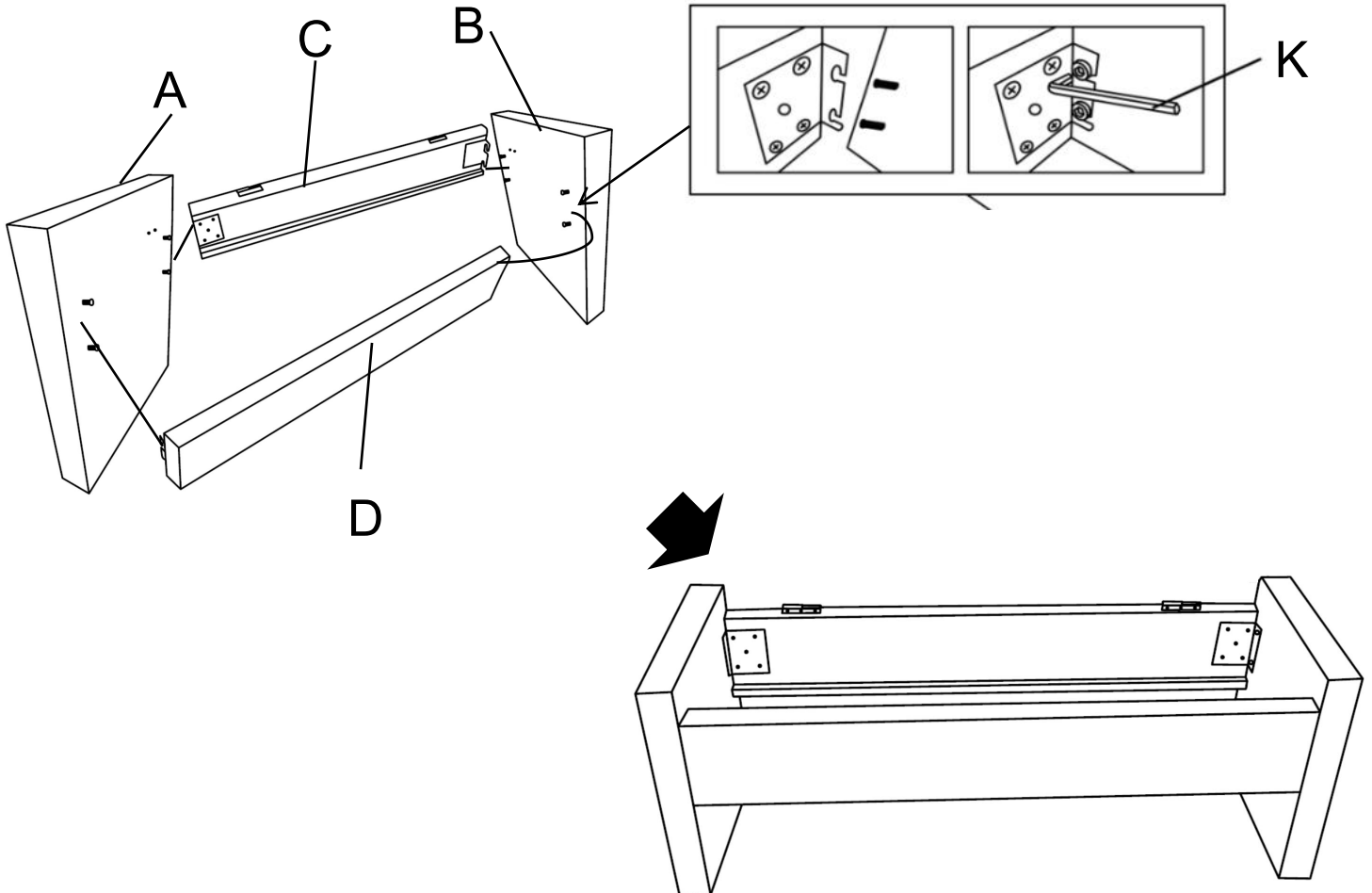

Step 3: Connect the **Bench Top(E)** with the **Back Panel(C)**

Notice: You need insert these two hinges together in same time to connect this two parts properly.

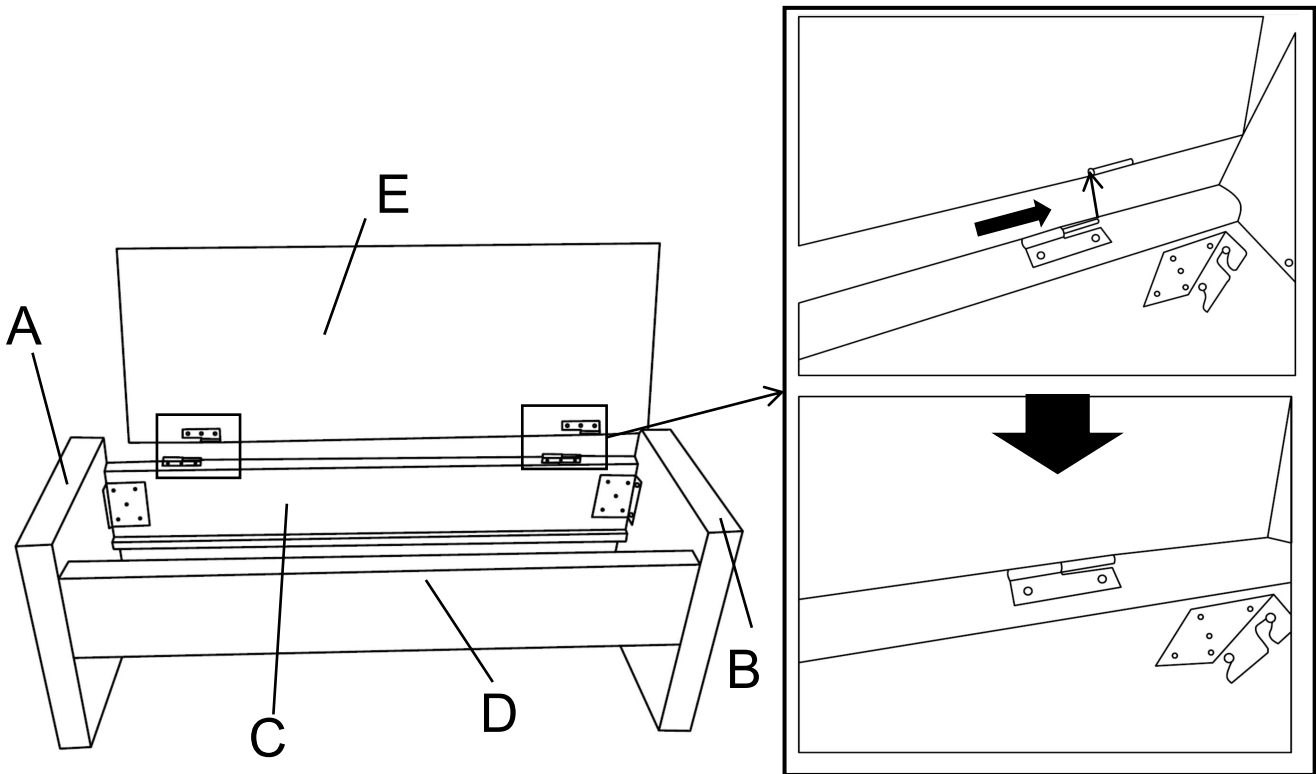

Step 4: Connect the **Left Hinge(G)** to the **Left Arm(A)** and **Bench Top(C)** and the **Right Hinge(H)** to the **Right Arm(B)** and **Bench Top(C)** with **Bolt(J)** and **Allen Wrench(K)**.

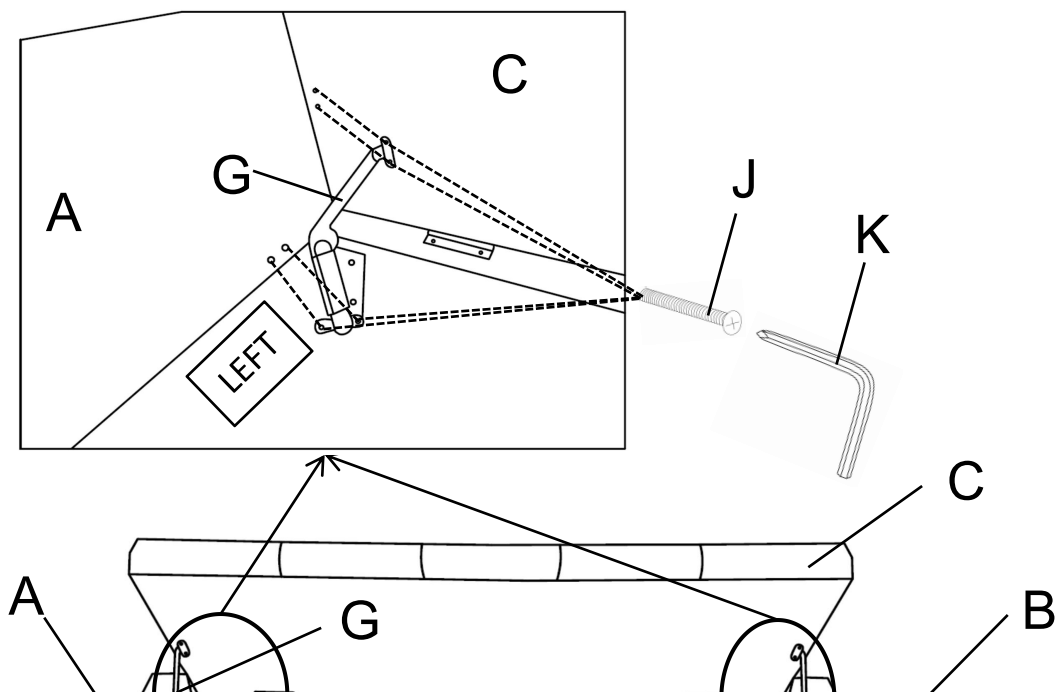

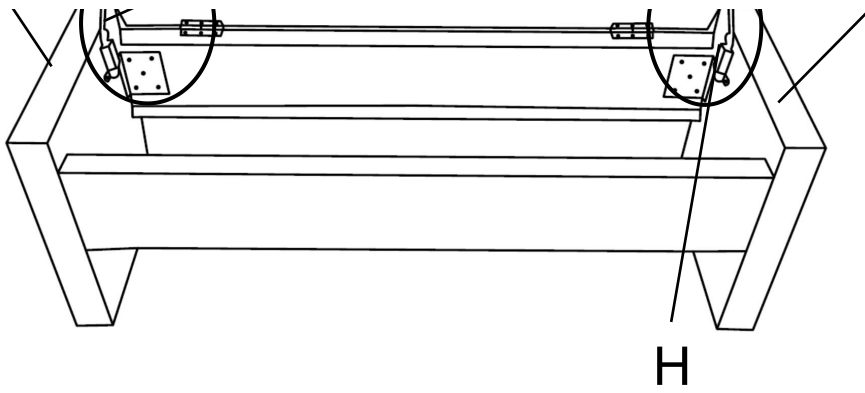

Step 5: First put one piece of **Baseplate(F)** into the Bench and move it to the left then put another into the Bench and move it to the Right

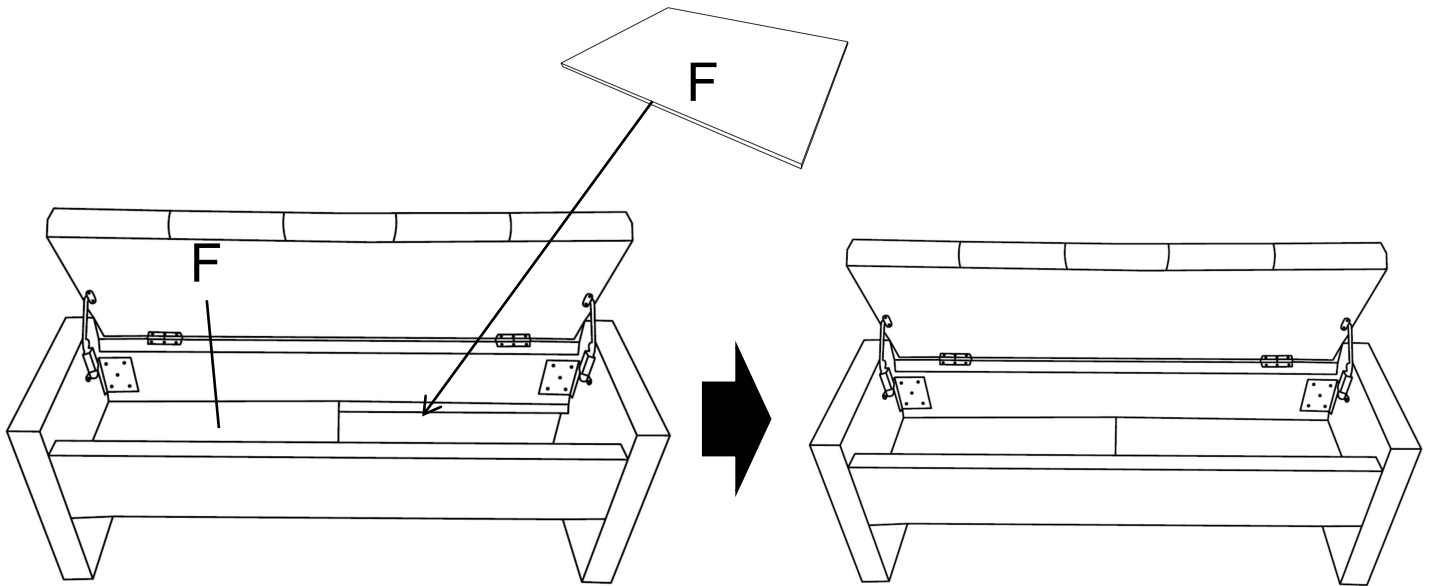

Step 6: Your Storage Bench has been assembled complete, **Enjoy It!**

