

# DC003 Assembly Instructions

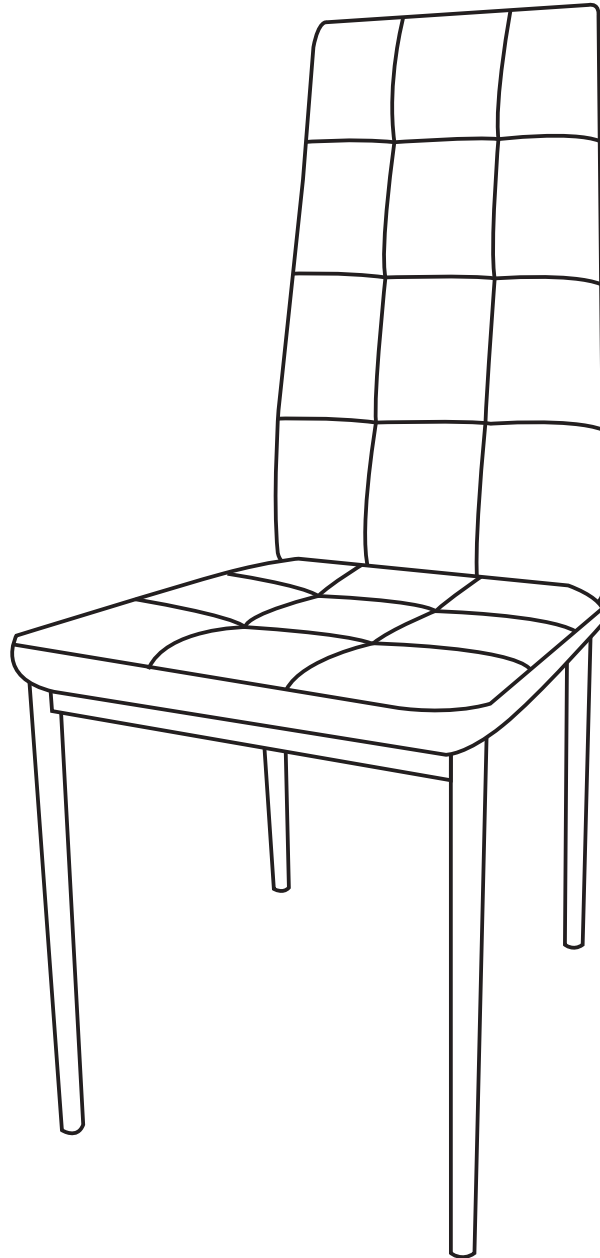

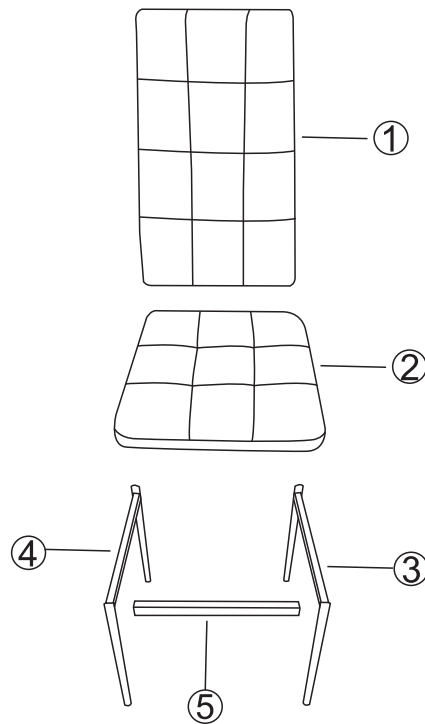





## Parts List



P.1

## Accessory List

Ax2  6*40	Bx10  6*14	Cx1  M5	Dx4  4*45	Ex4  6*14	Fx4 
----------------------------------------------------------------------------------------------------	-----------------------------------------------------------------------------------------------------	--------------------------------------------------------------------------------------------------	----------------------------------------------------------------------------------------------------	----------------------------------------------------------------------------------------------------	----------------------------------------------------------------------------------------------

P.2

## STEP I The degree of screw tightening is initially controlled at 50%.

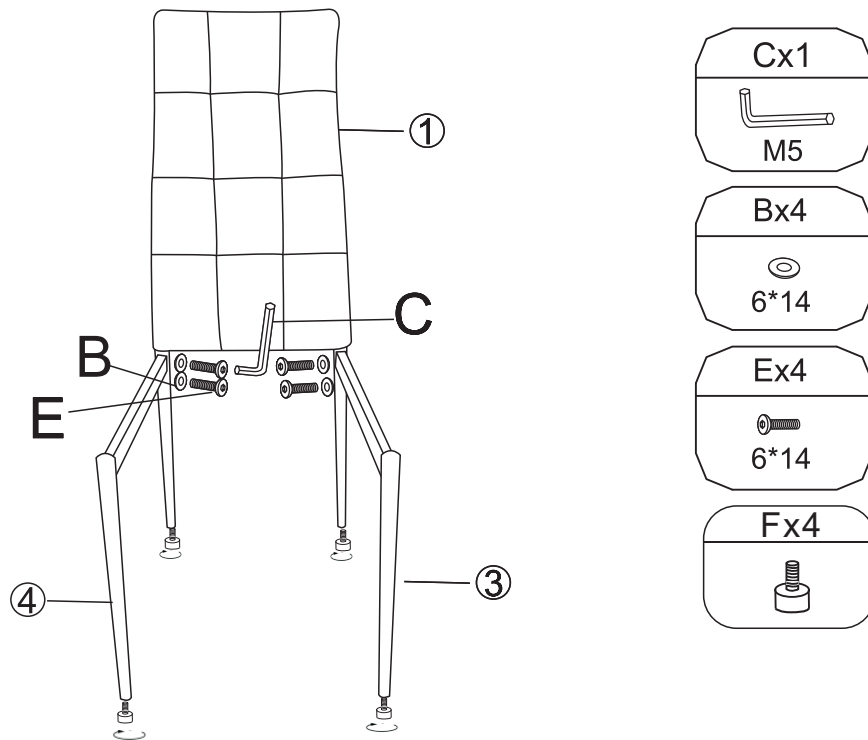

P.3

### CHAIR AS A STEP LADDER :

- USE THIS PRODUCT ONLY FOR SEATING ONE PERSON AT A TIME.
- DO NOT USE THIS CHAIR UNLESS ALL BOLTS, SCREWS AND KNOBS ARE FIRMLY SECURED.
- CHECK ALL PARTS TO BE COMPLETE TIGHTED BEFORE USING, AND RECHECK EVERY 4 MONTHS AFTER AT LEAST.
- IF PARTS ARE MISSING, BROKEN, DAMAGED OR WORN, STOP USING THIS PRODUCT UNTIL REPAIRS ARE MADE USING FACTORY AUTHORIZED PARTS.
- FAILURE TO FOLLOW THESE WARNINGS COULD RESULT IN SERIOUS INJURY.

**STEP 2** The degree of screw tightening is initially controlled at 50%.

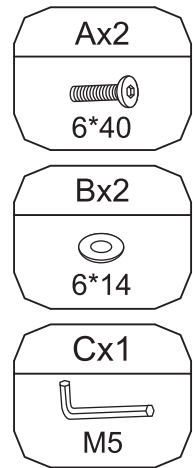
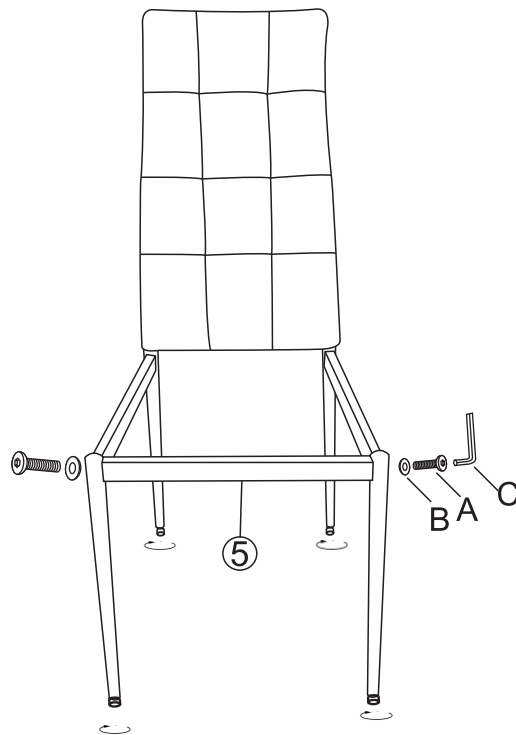

P. 4

**STEP 3** The degree of screw tightening is initially controlled at 50%.

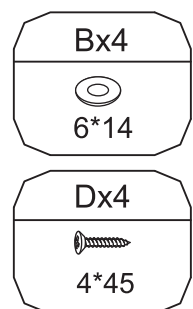
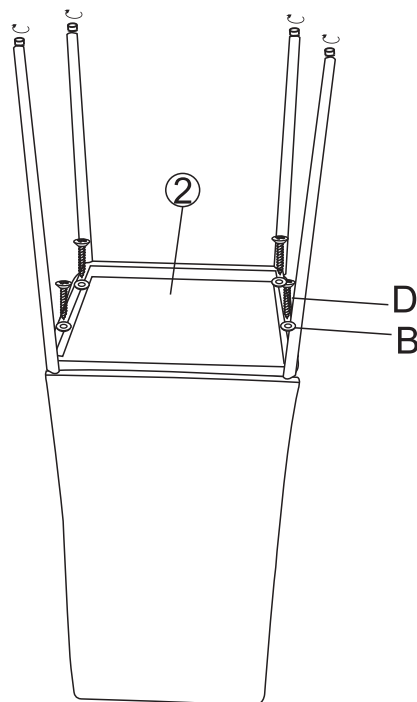

P. 5

**STEP 4** Tighten all screws to their final positions to complete the assembly.

