

INSTALLATION

Product Manual

Version: 200068-00-24A-XN

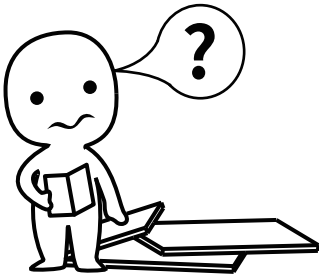

IMPORTANT INFORMATION!

please read the entire manual before starting to assemble and/or using this product. follow the manual thoroughly and keep it for further reference.

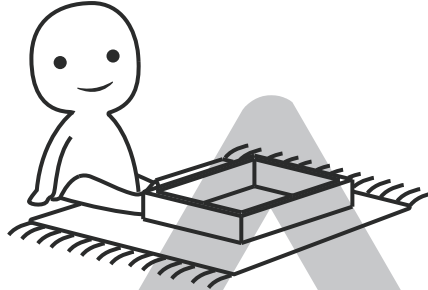
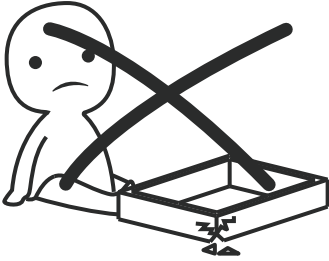

AVOID SCRATCHES!

In order to avoid scratching this furniture should be assembled on a soft layer- could be a rug.

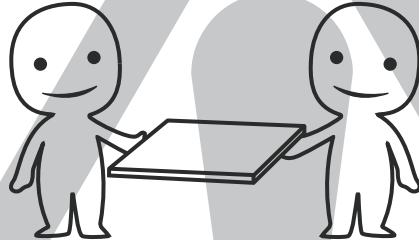

IMPROVE EFFICIENCY !

Try to find a partner to install with you, which can speed up the installation efficiency and shorten the time.

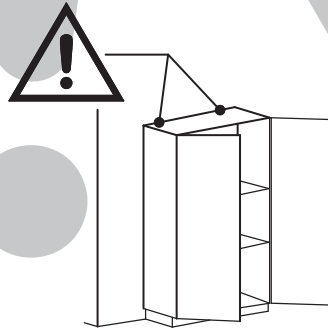
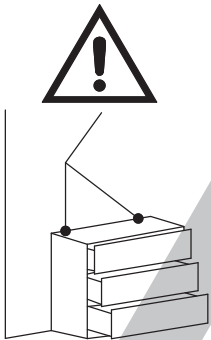

ANTI-TOPPLE WARNING !

Overtured furniture can cause serious or fatal crush injuries. To prevent tipping over, be sure to use the wall attachment, if not included with this product. Please purchase the wall attachment that fit your wall. If unsure, seek professional advice. Please read and follow each step of the instructions carefully.

IMPORTANT !

It is important that any product which is assembled using any kind of screw is re-tightened 2 weeks after assembly, and once every 3 months - in order to assure stability through-out the lifespan of the product.

For regular maintenance and cleaning of the product, for the frame, please use a rag dipped in neutral detergent to fully wipe it, and then dry it with a clean rag. For glass materials, wipe with a rag dampened with water glass cleaner, and then dry with a dry rag.

Do not use an electric screwdriver, and do not use too much force when installing, because the board is easy to break.

! WARNING



Children have died from furniture tipover. To reduce the risk of furniture tipover:

- . ALWAYS install tipover restraint provided.
- . NEVER put a TV on this product.
- . NEVER allow children to stand, climb or hang on drawers, doors, or shelves.
- . NEVER open more than one drawer at a time.
- . Place heaviest items in the lowest drawers.



! WARNING

Fall Hazard Children have suffered serious injuries after falling from changing tables. Falls can happen quickly.

- **STAY** within arm's reach of the child.
- **ALWAYS** secure this unit to the support surface using the screws provided. See instructions.
- Read all instructions before use of the changing top.
- **KEEP THESE INSTRUCTIONS IN A SAFE PLACE FOR FUTURE USE.**
- Inspect the changing top periodically. Do not use the changing top if it is damaged or broken. Contact Delta Children's Products with any questions.
- Tighten all loose screws and bolts before each use.
- The maximum recommended weight of the child is 11kg for the changing unit.
- The maximum recommended age of the child is 12months for the changing unit.
- The changing pad used should be 43.3" x 16.1" with a maximum thickness of 1".
- Be aware of the risk of open fires and other sources of strong heat, such as electric bar fires, gas fires, etc. in the near vicinity of the changing unit.

Do not leave the child unattended



NINGBO JIANGBEI FUFU ELECTRONIC COMMERCE CO LTD

ADRESS:ROOM 702,NO.1,HUAMAO HEADQUARTERS, SOUTHERN BUSINESS DISTRICT,
Yinzhou District, Ningbo City, Zhejiang Province

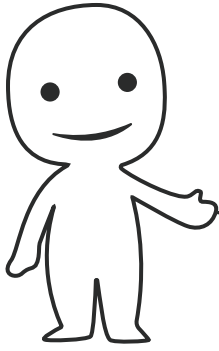

Please prepare the following tools

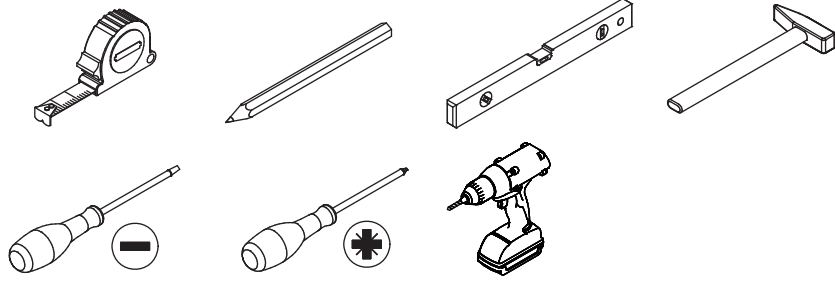

When installing, please carefully confirm whether each screw corresponds to the manual, accessories with similar shapes can be distinguished by size

<p>A x 55</p>  <p>∅ 6 x 35 mm</p>	<p>B x 55</p>  <p>∅ 15 x 9 mm</p>	<p>C x 16</p>  <p>∅ 8 x 30 mm</p>	<p>D x 4</p>  <p>∅ 8 x 50 mm</p>	<p>E x 9</p>  <p>∅ 4 x 35 mm</p>
<p>F x 72</p>  <p>∅ 3 x 12 mm</p>	<p>G x 30</p>  <p>∅ 4 x 30 mm</p>	<p>H x 8</p>  <p>∅ 3 x 14 mm</p>	<p>I x 2</p> 	<p>J x 16</p>  <p>∅ 3 x 16 mm</p>
<p>K x 16</p> 	<p>L x 6</p> 	<p>M x 1</p>  <p>∅ 4 x 14 mm</p>	<p>N x 2</p> 	<p>O x 1</p> 
<p>P x 1</p>  <p>∅ 6 x 30 mm</p>	<p>CR x 6</p>  <p>350mm</p>	<p>CL x 6</p>  <p>350mm</p>	<p>DR x 6</p>  <p>350mm</p>	<p>DL x 6</p>  <p>350mm</p>
<p>Q x 12</p>  <p>∅ 3 x 12 mm</p>				

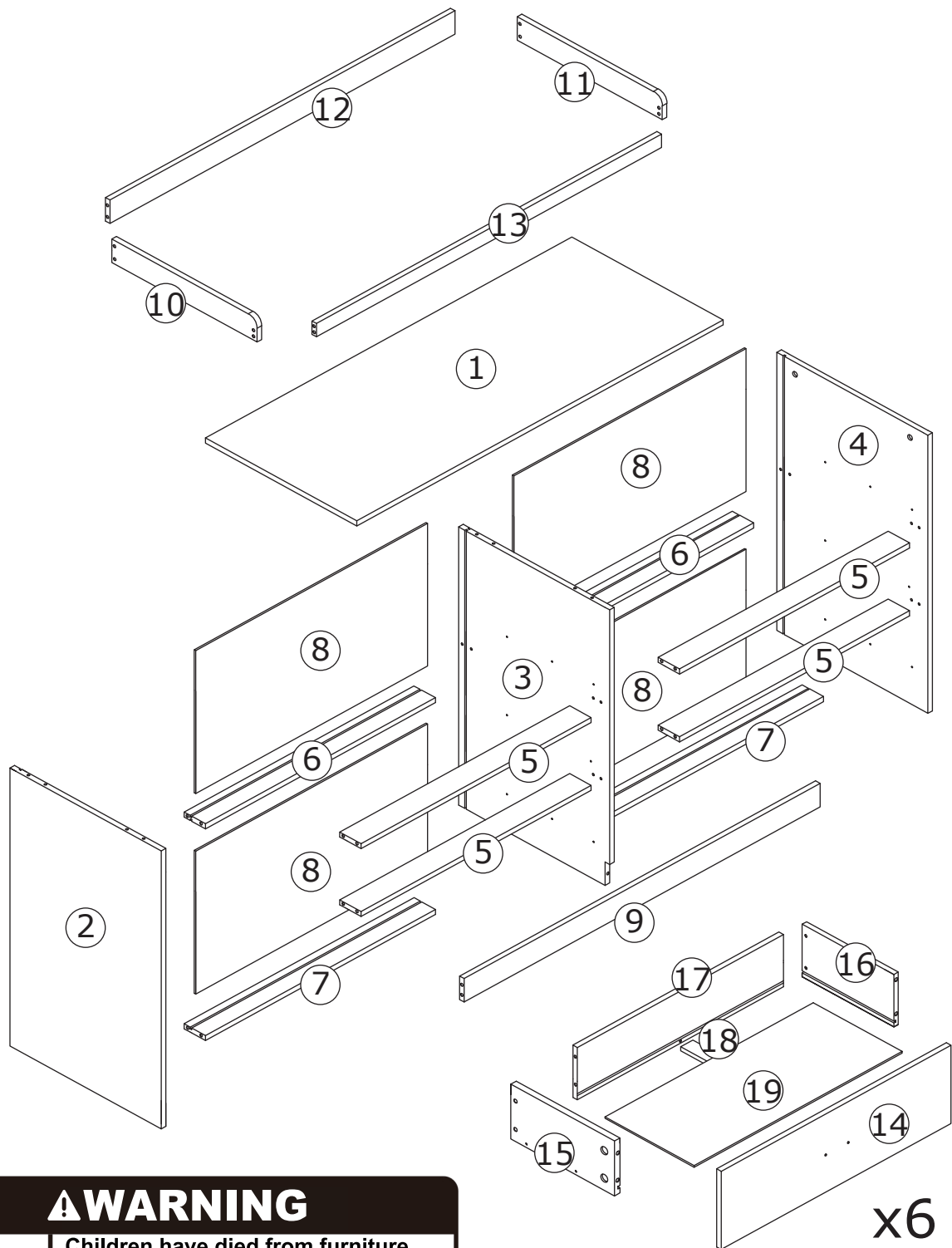

⚠ WARNING



Children have died from furniture tipover. To reduce the risk of furniture tipover:

- ALWAYS install Anti-tip device provided.
- NEVER put a TV on this product.
- NEVER allow children to stand, climb or hang on drawers, doors, or shelves.
- NEVER open more than one drawer at a time.
- Place heaviest items in the lowest drawers.



*This is a permanent label.
Do not remove!*

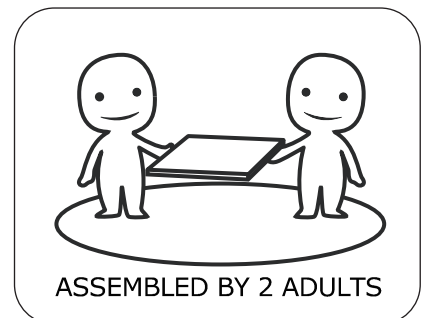

1

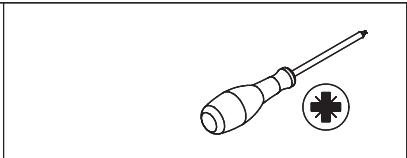
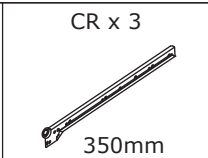
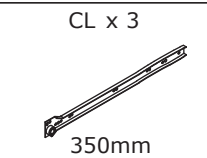
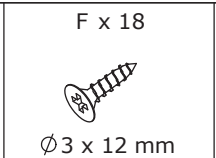
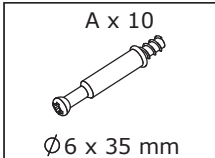

Insert quickfit screw(A) into corresponding holes in plate 2 and 4 with a screwdriver as shown.

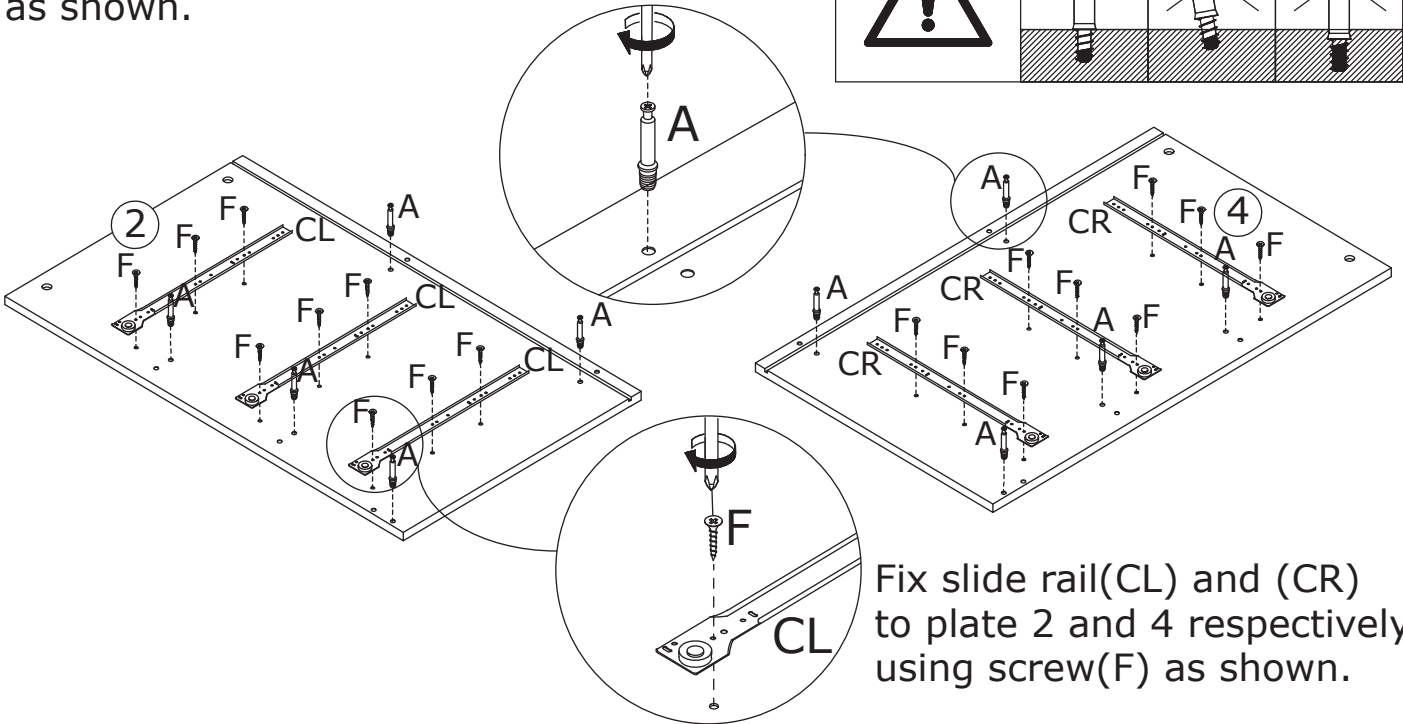
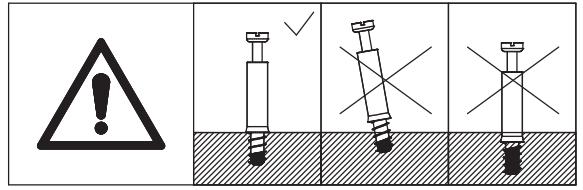

Fix slide rail(CL) and (CR) to plate 2 and 4 respectively using screw(F) as shown.

2

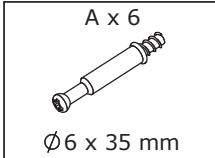

Insert quickfit screw(A) into corresponding holes in plate 1 with a screwdriver as shown.

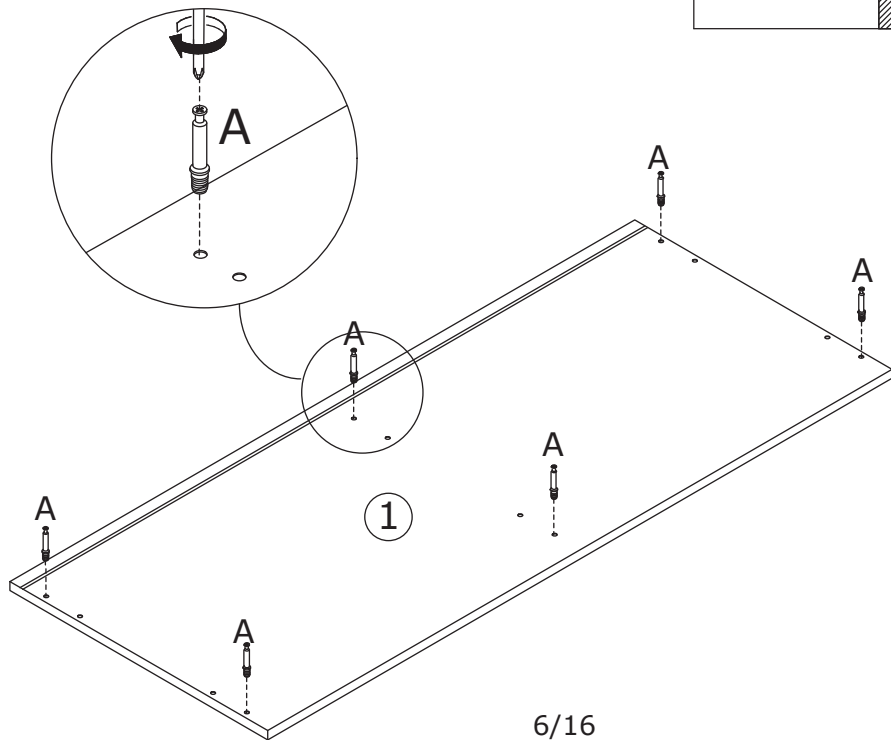
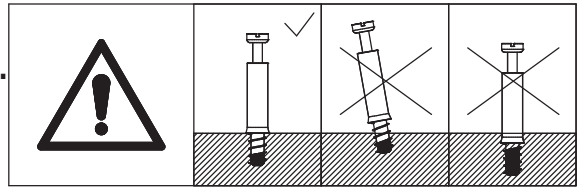

3

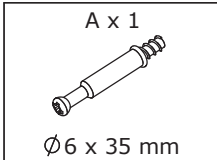

Insert quickfit screw(A) into plate 9 as shown.

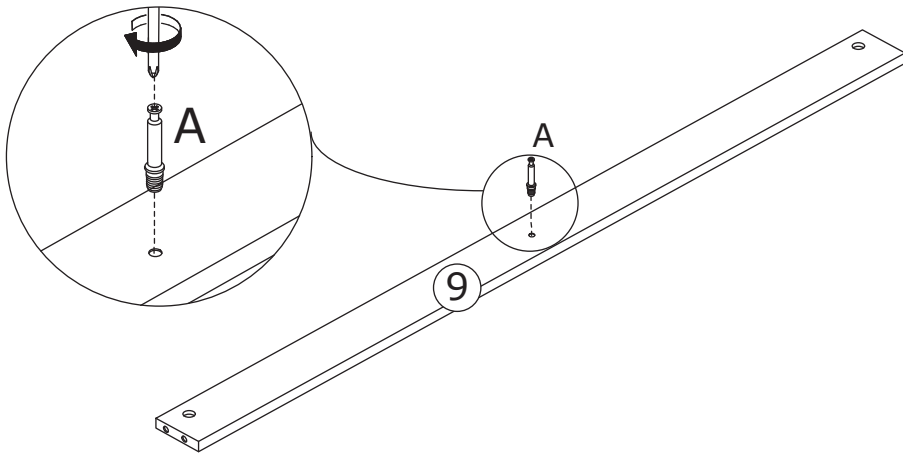
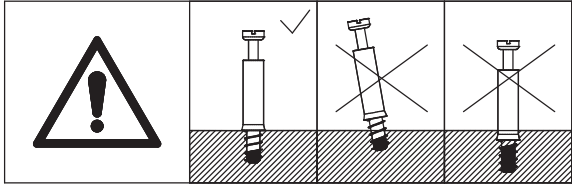

4

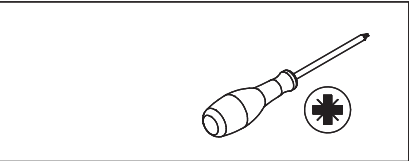
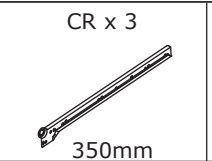
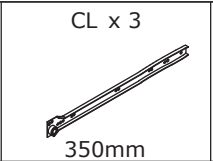
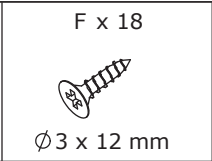
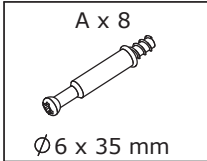

Insert quickfit screw(A) into corresponding holes in plate 3, and fix slide rail(CR) using screw(F) at first.

Flip the plate, Insert quickfit screw(A) into and fix slide rail(CL) using screw(F) as shown.

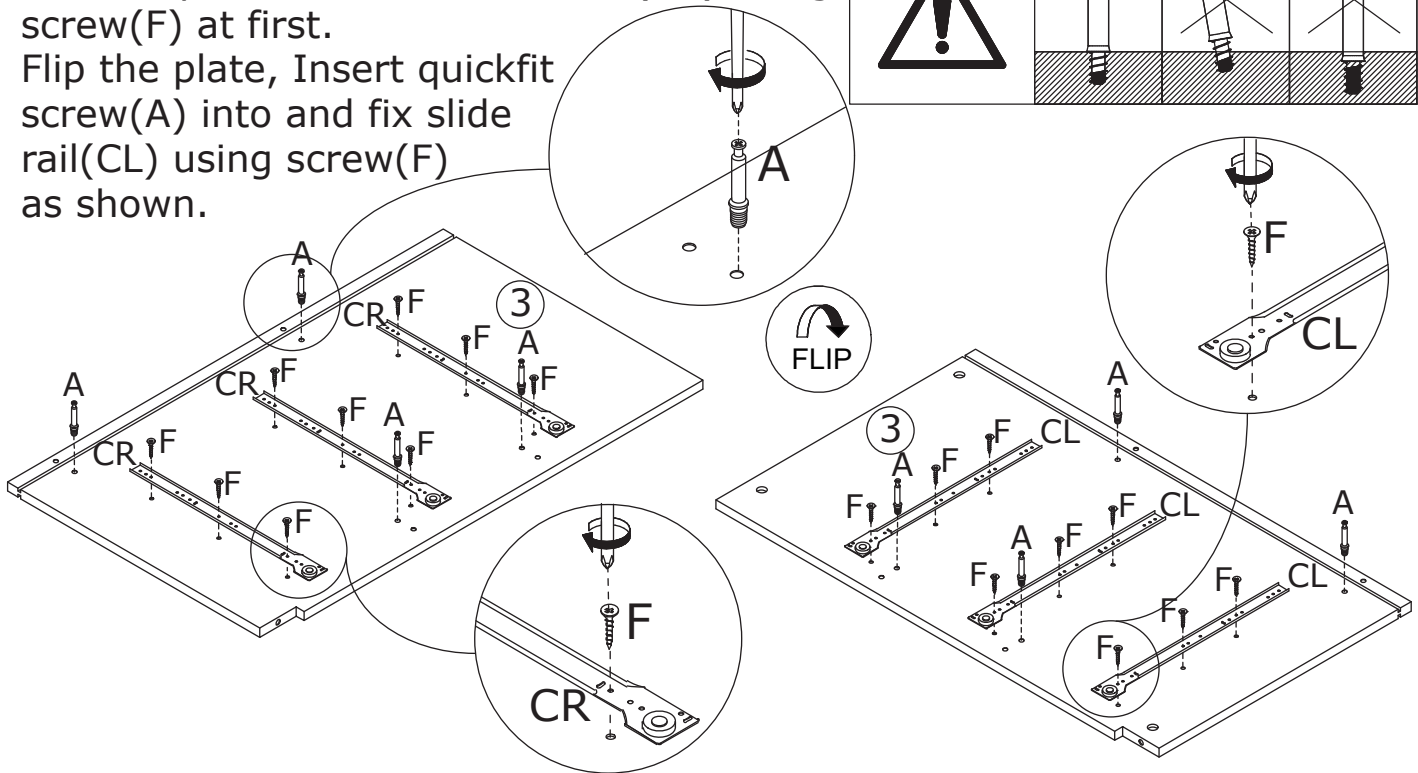
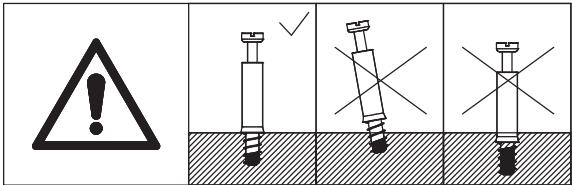

5

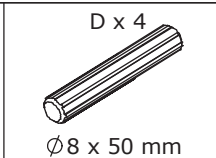
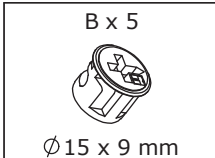

Attach plate 7,6 and 5 to plate 3 with wooden dowel(D), attach plate 9 to plate 3. Put cam lock(B) into holes in plate 5,6,7,3 and turn clockwise to tighten as shown.

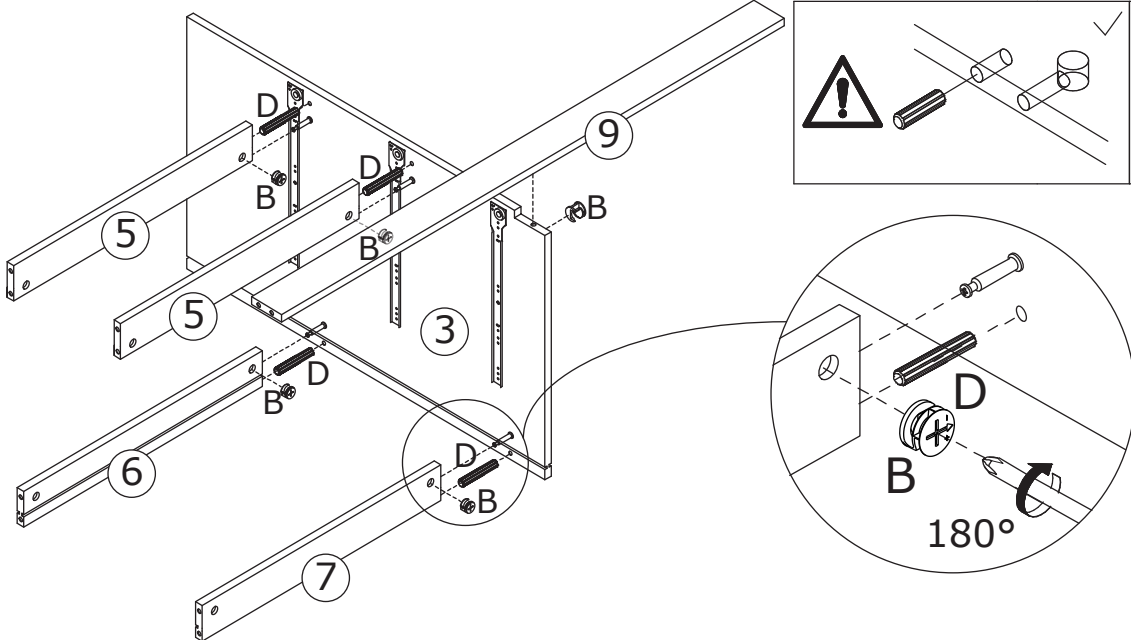
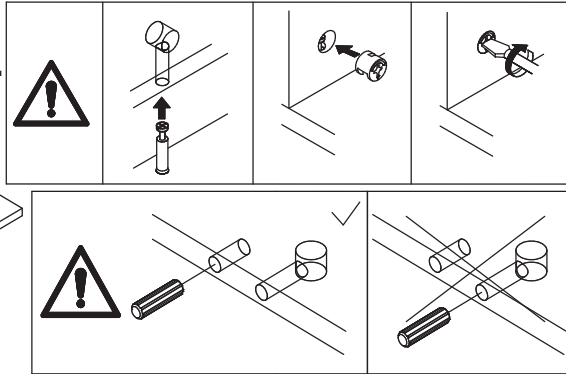

6



Slide plate 8 along grooves as shown.

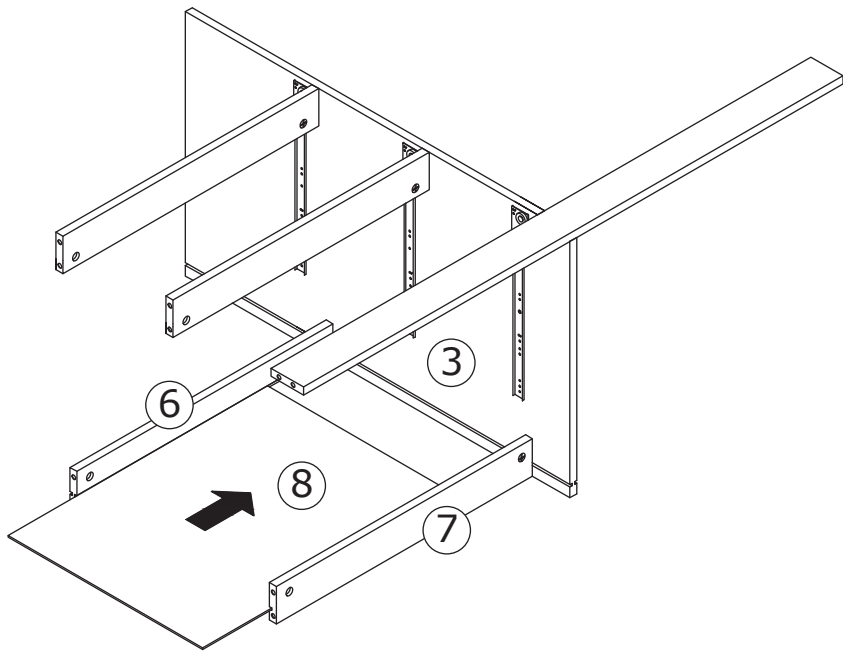

7

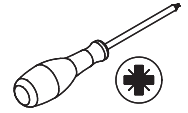
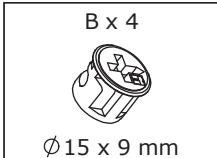

Attach another plate 7,6 and 5 to plate 3 with wooden dowel(D).

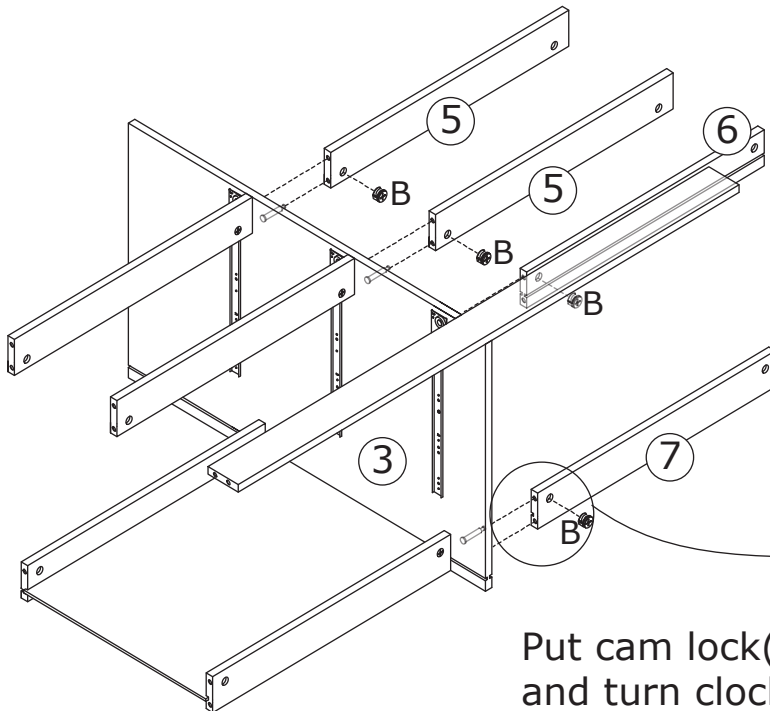
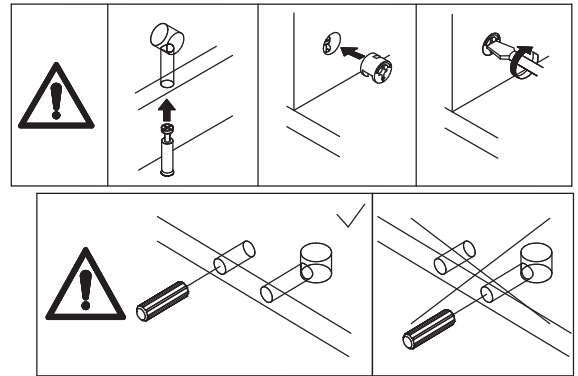

Put cam lock(B) into holes in plate 5,6,7 and turn clockwise to tighten as shown.

8



Slide plate 8 along grooves as shown.

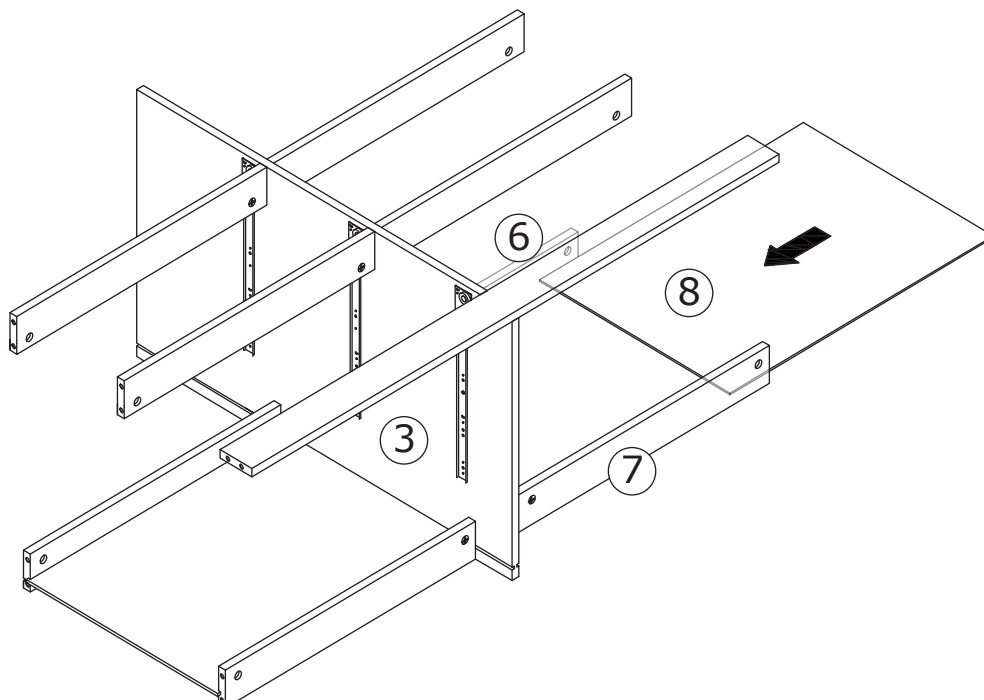

9

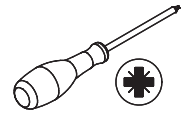
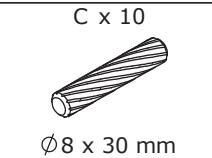
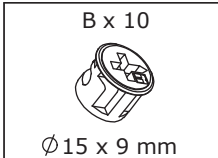

Connect plate 2 and 4 with the component using wooden dowel(C) at first. Put cam lock(B) into holes in plate 5,6,7,9 and turn clockwise to tighten as shown.

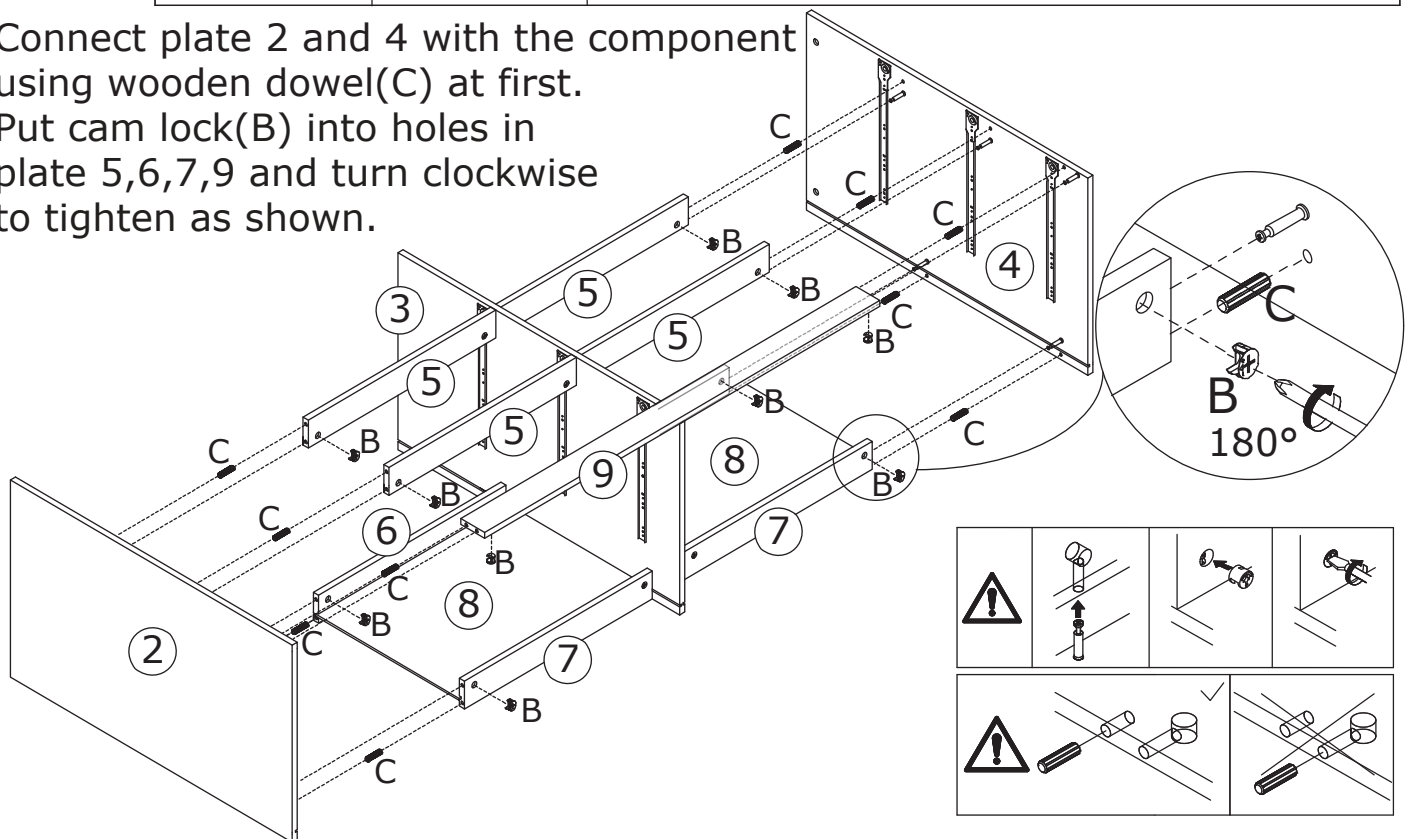

10

Slide two plate 8 along grooves as shown.

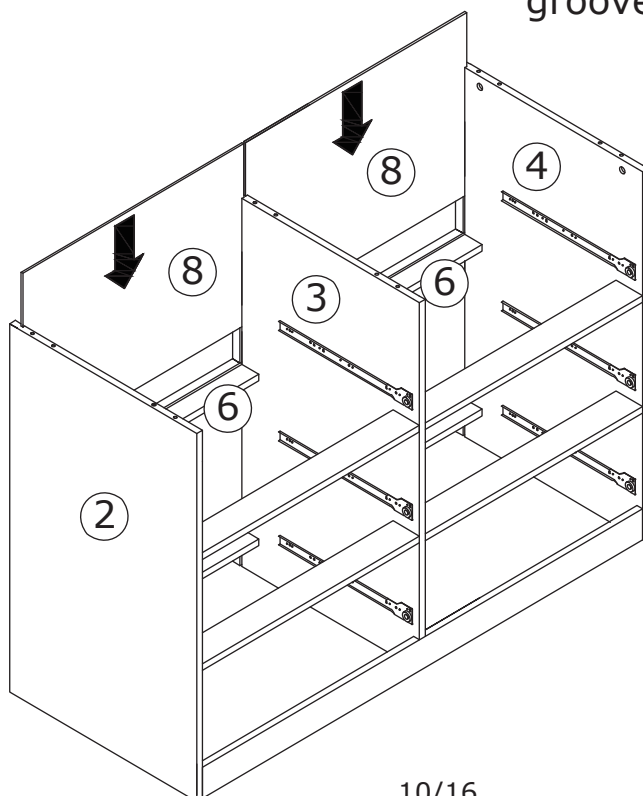

11

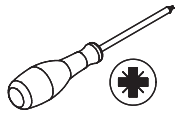
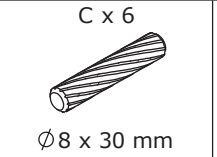
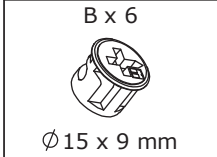

Cover plate 1 to plate 2,3 and 4 with wooden dowel(C), put cam lock(B) into holes in plate 2,3,4 and turn clockwise to tighten as shown.

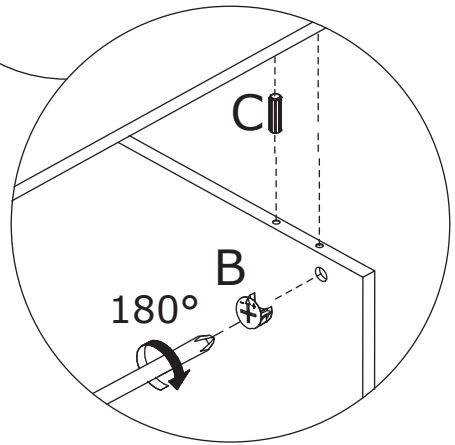
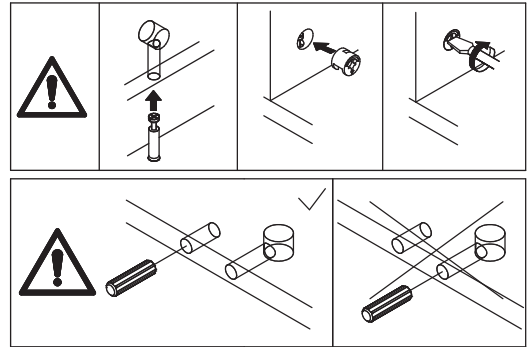
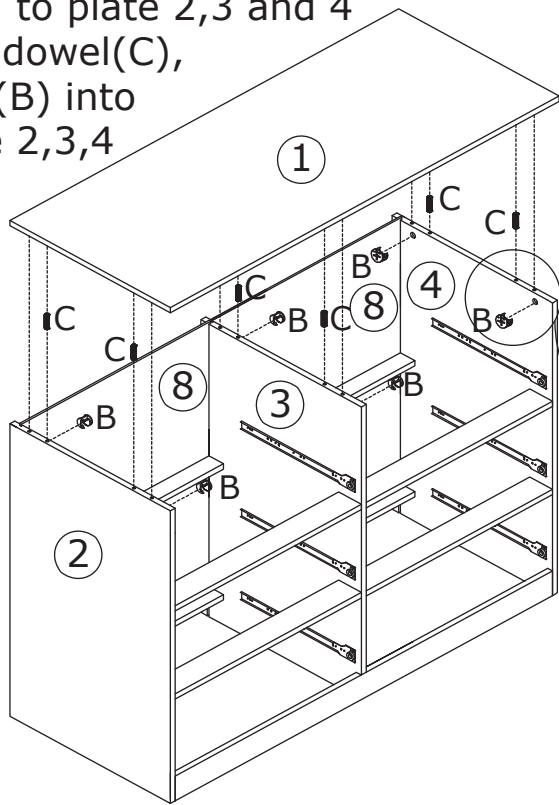

12

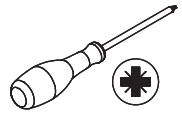
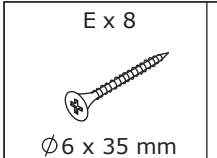

Fix plate 10 and 11 to plate 12 and 13 using screw(E) as shown.

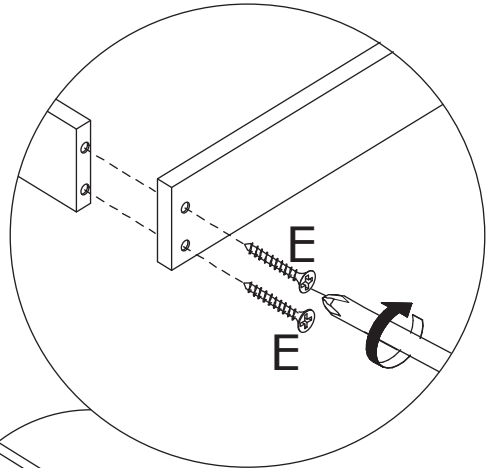
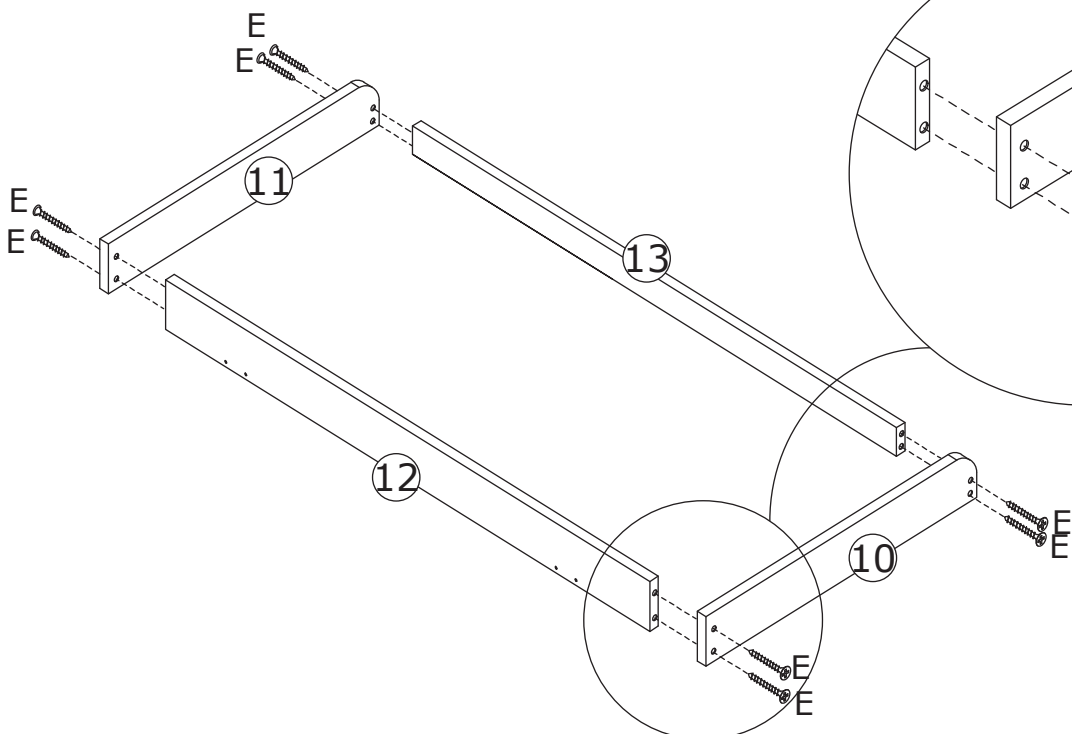

13

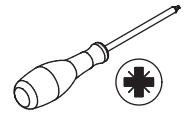
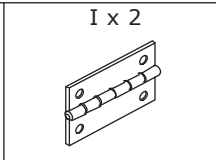
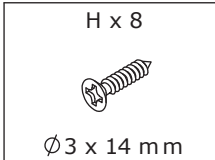

Fix the component to the top using part(I) with screw(H) as shown.

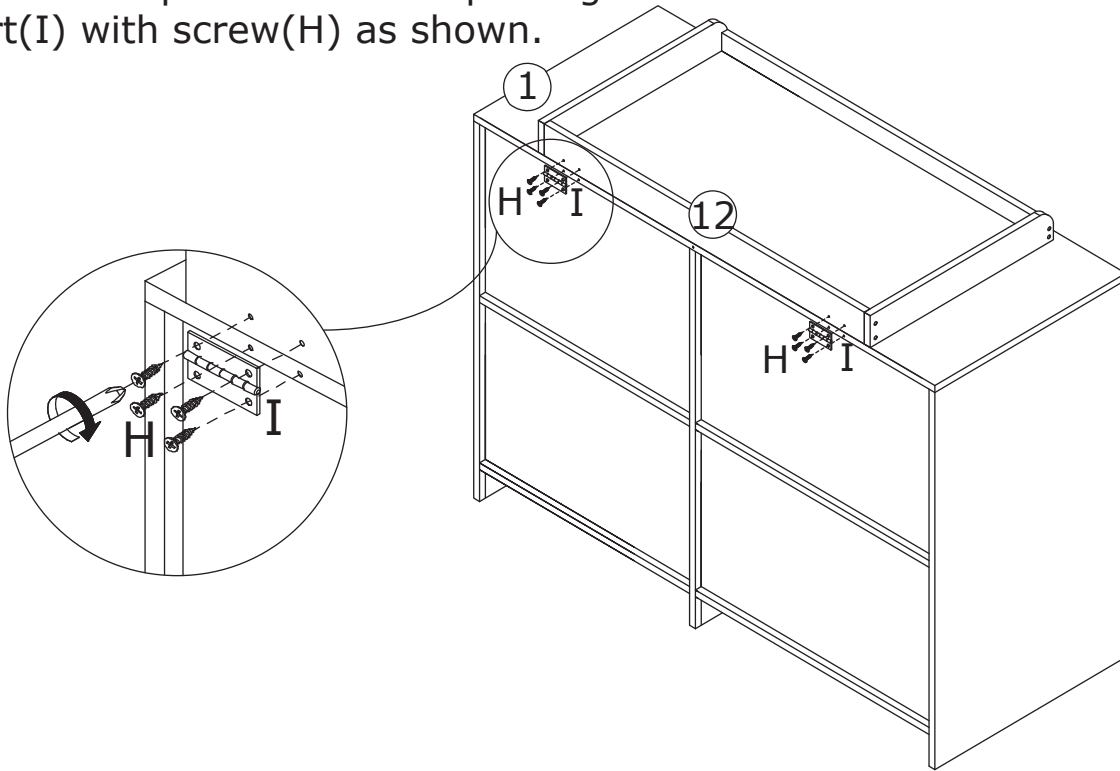

14

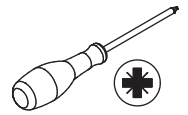
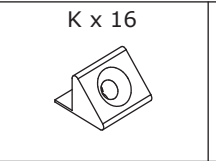
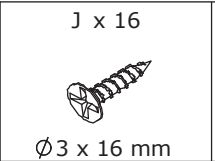

Reinforce back plate 8 using part(K) with screw(J) as shown.

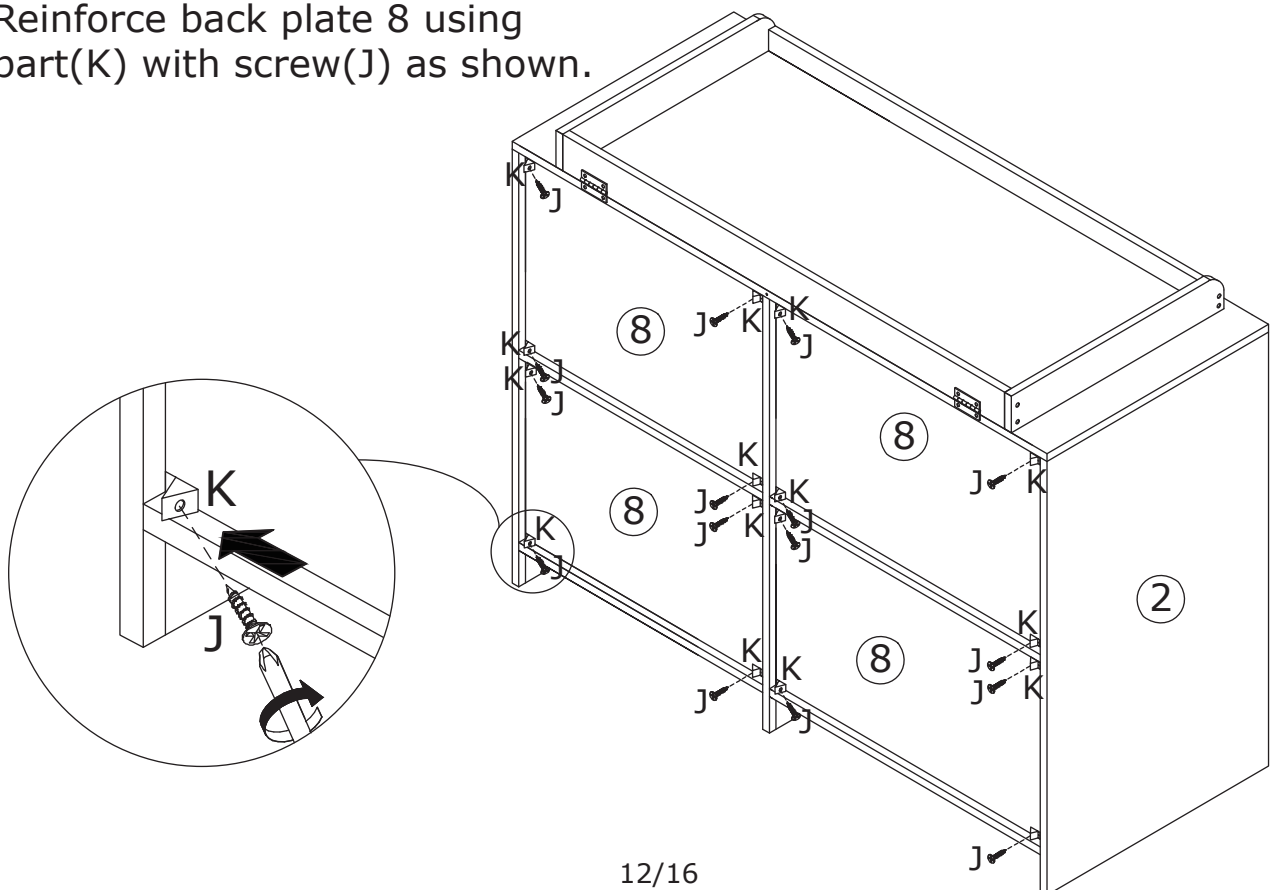

15

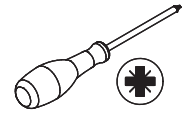
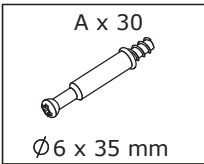

Insert quickfit screw(A) into plate 14 as shown.

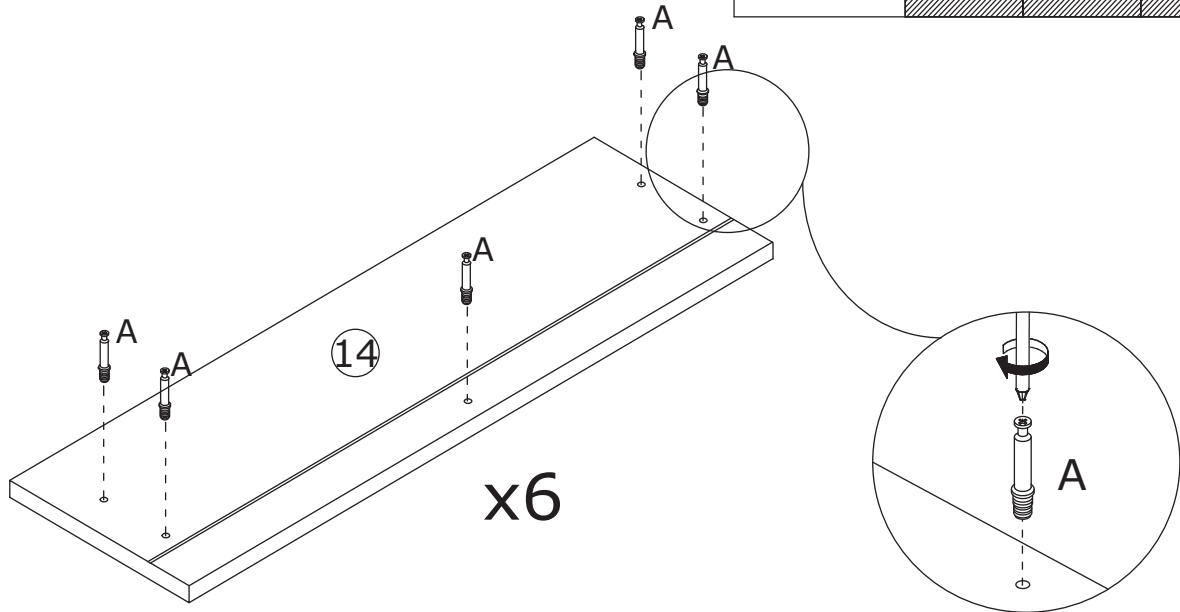
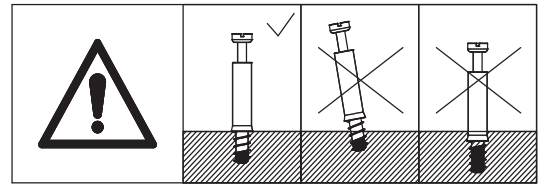

16

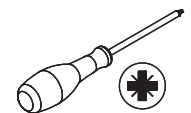
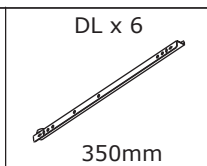
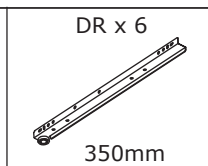
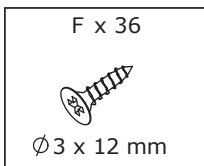

Fix runner(DL) and (DR) to plate 15 and 16 respectively using screw(F) as shown.

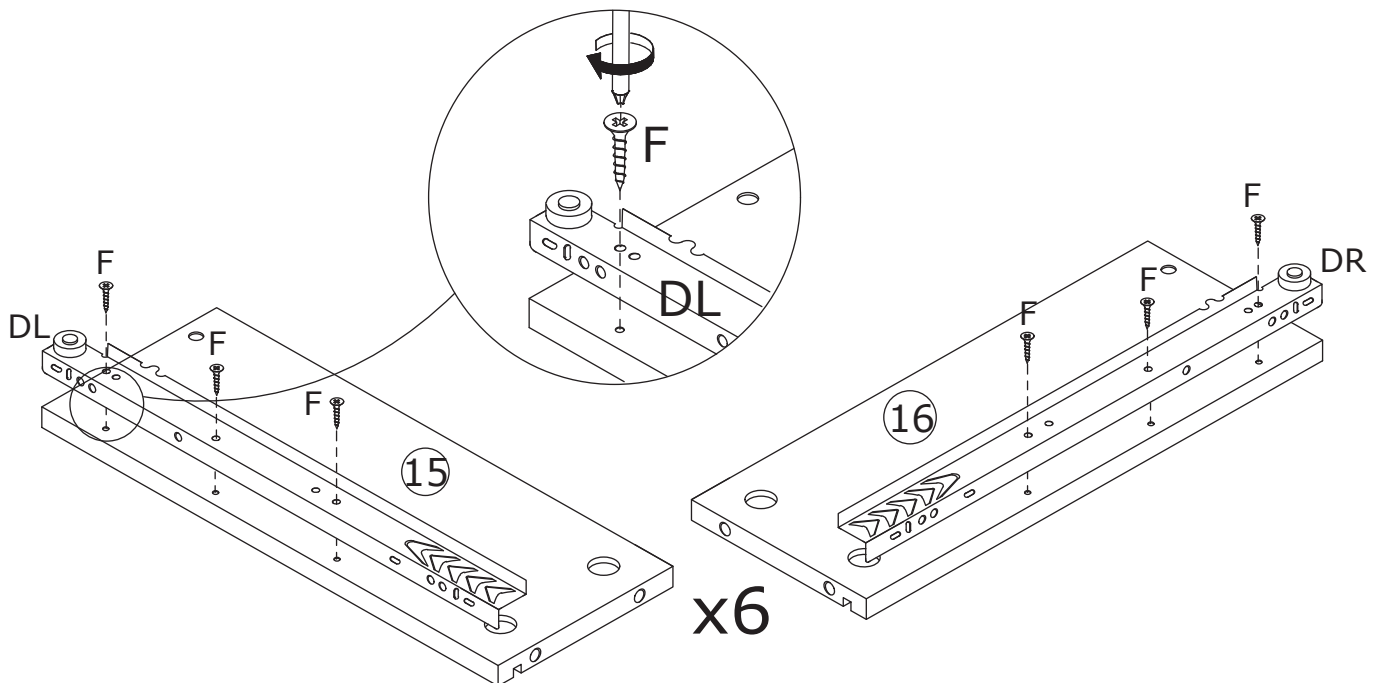

17

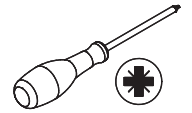
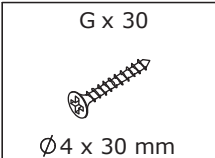

Fix plate 15,18 and 16 to plate 17 using screw(G) as shown.

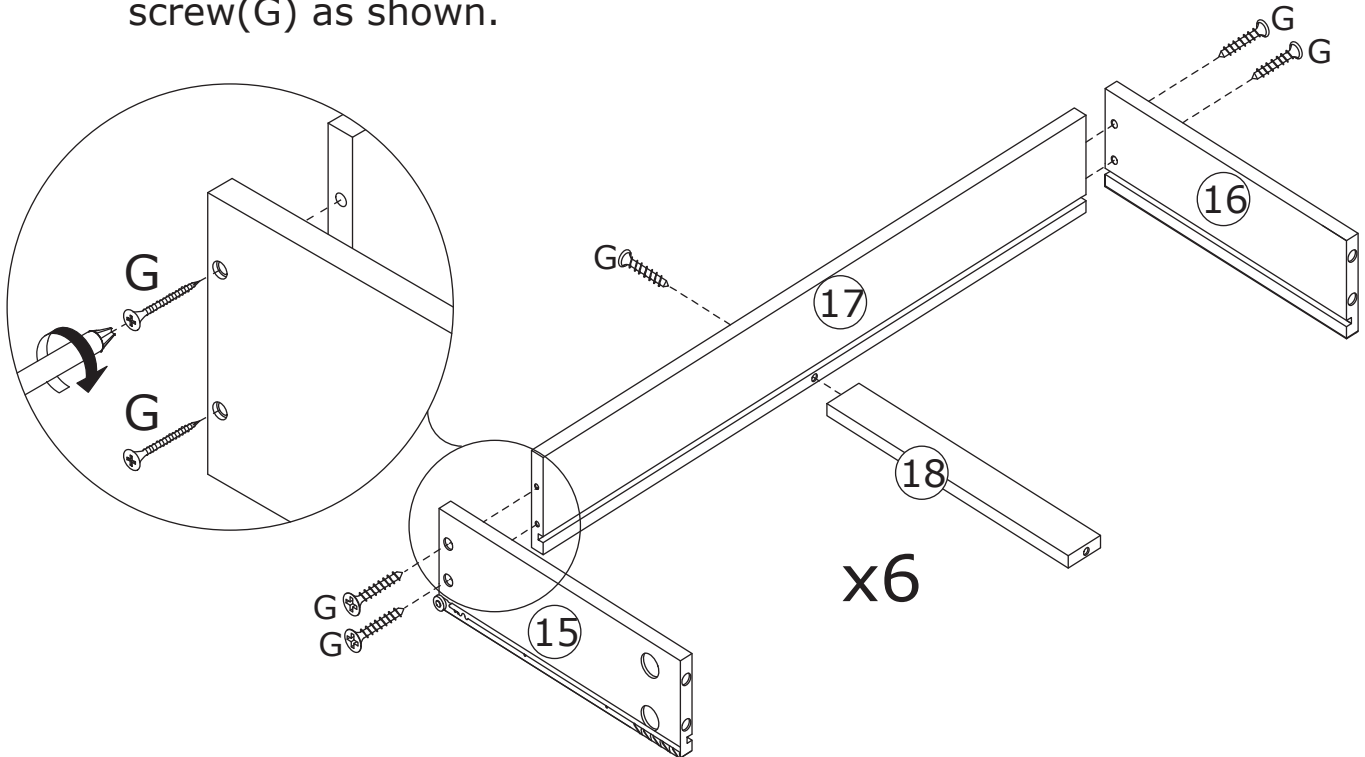

18

Slide plate 19 along grooves as shown.

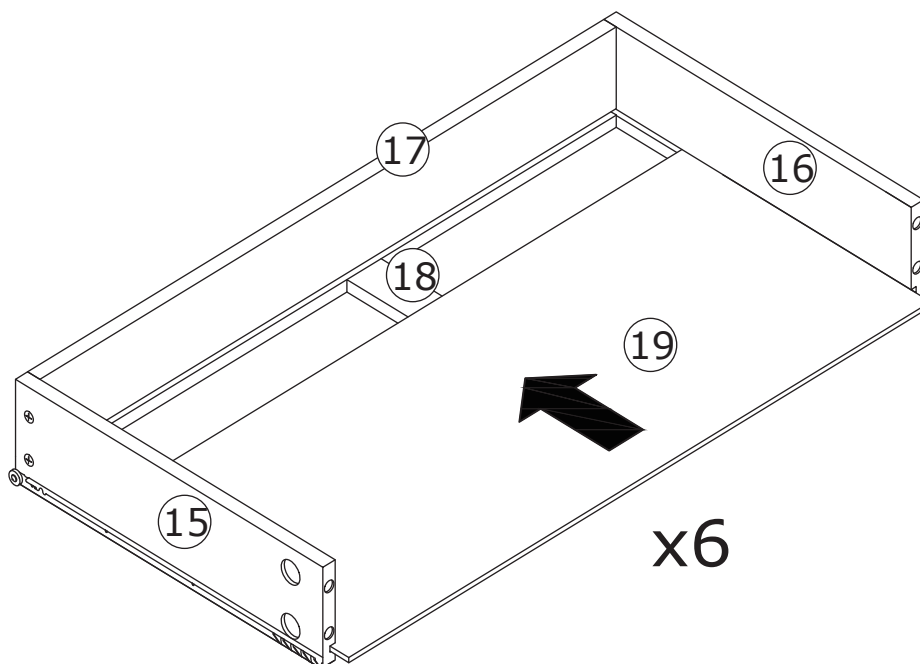

19

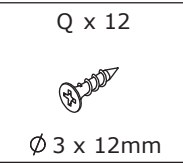
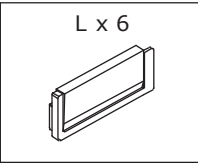
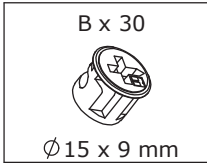

Attach plate 14 to the drawer.
And put cam lock(B) into holes in plate 15,16
and turn clockwise to tighten as shown.
Fix handle(L) to plate 14 using screw(Q)
as shown.

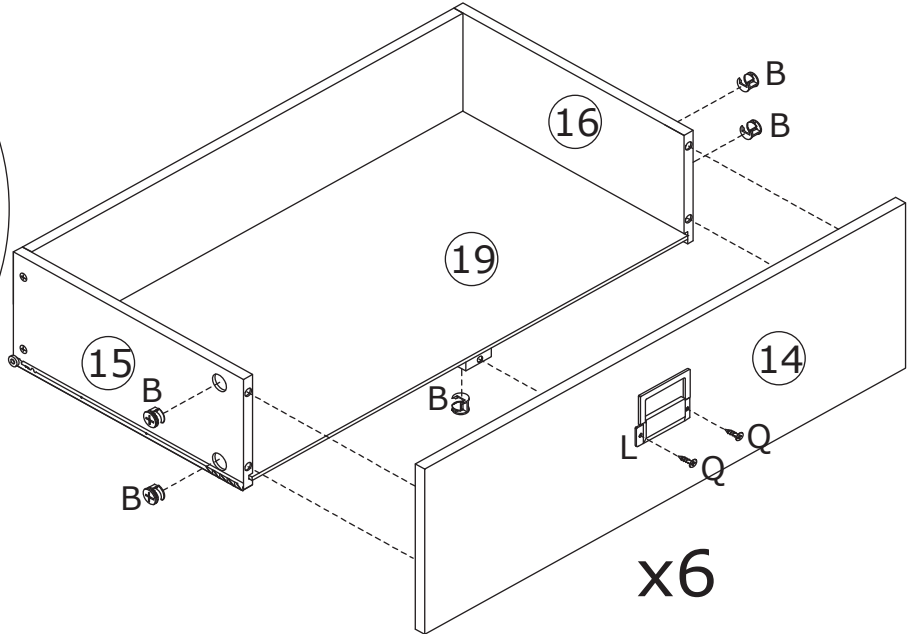
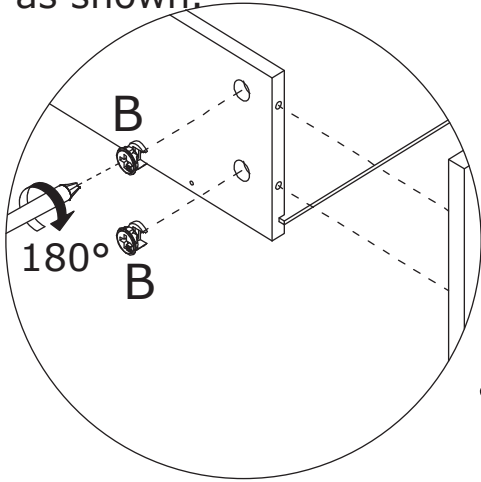
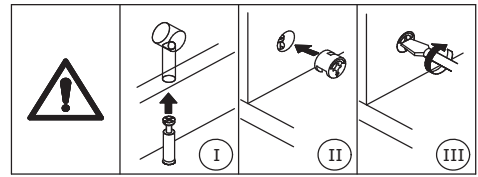





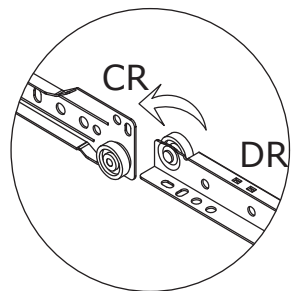
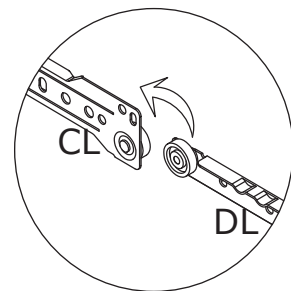
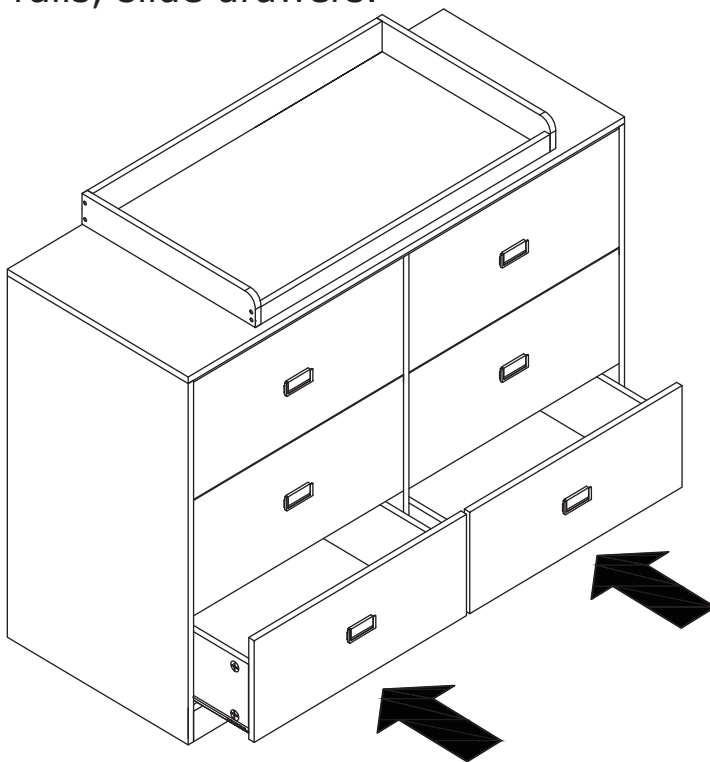

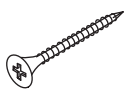

20

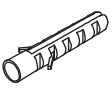
Align rails, slide drawers.

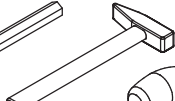
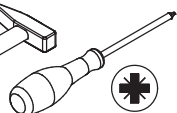

21

E x 1  Ø4 x 35 mm	M x 1  Ø4 x 14 mm	P x 1  Ø6 x 30 mm	N x 2 				
O x 1 							

Install anti-tipping device as shown.

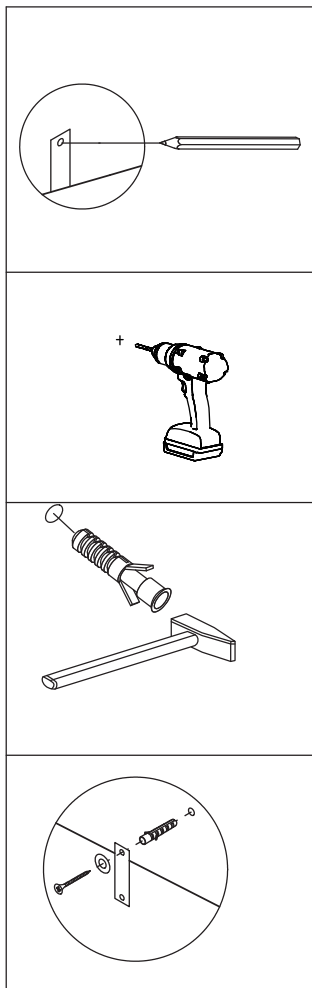
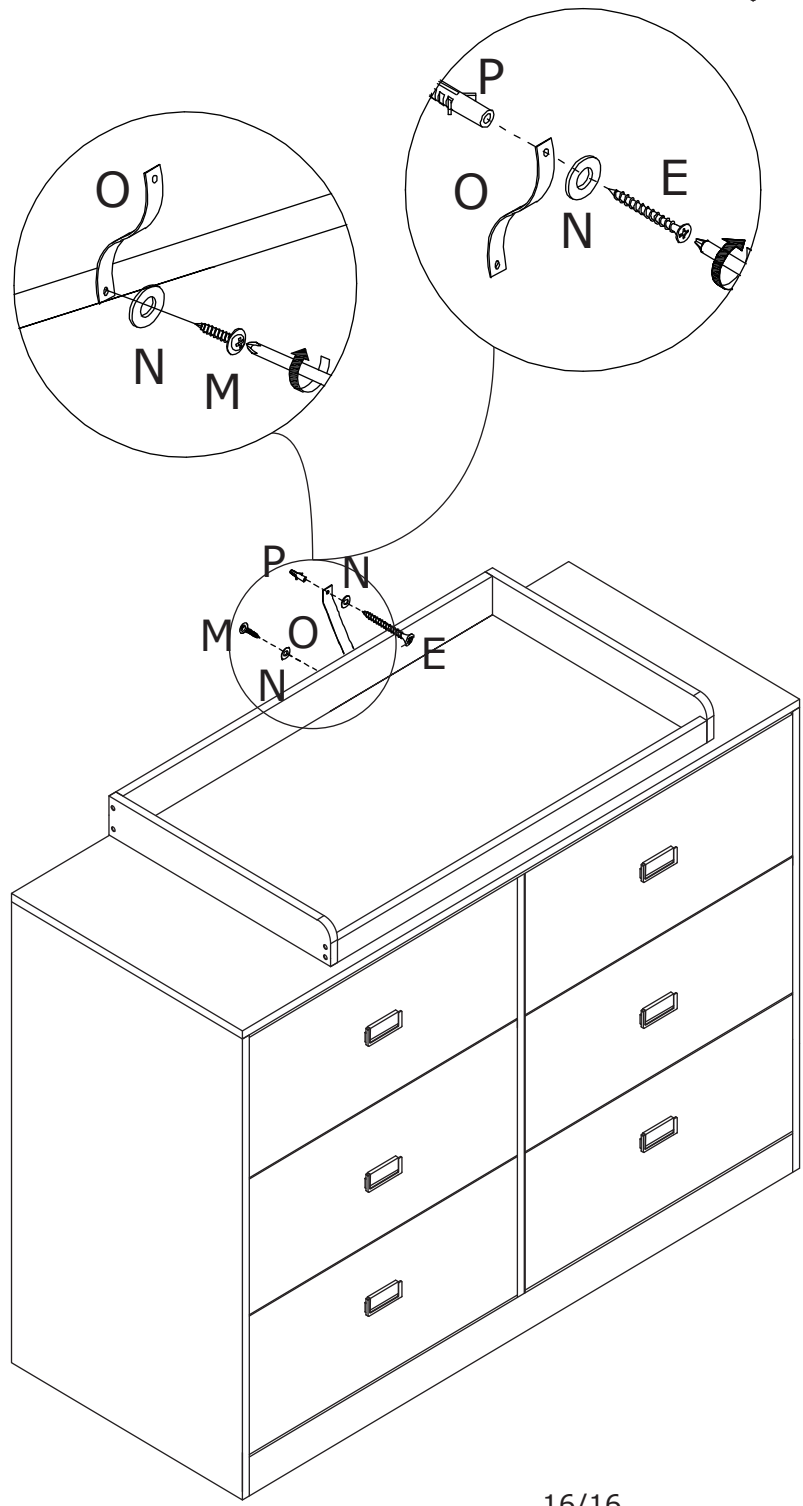
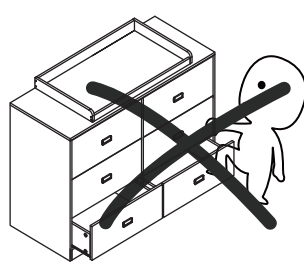
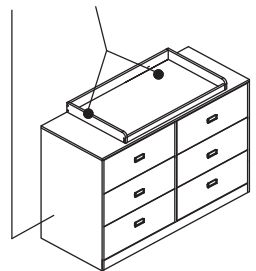

WARRANTY

WARRANTY CLAIMS

- There is a 30-day warranty for broken furniture or any other problems that do not work properly. The warranty will start from the date of purchase which must be verified by proof of purchase.
- Before making a claim, we may be able to answer your query, simply call us. Please leave your purchase order number, along with some details of the problem, if you want a replacement part. We will arrange within 48 hours. If there is out of stock, we will reply with a shipping date.
- The product must be used in accordance with the instructions provided. For health reasons.
- For other reasons, if the furniture needs to be returned, it must be cleaned and dried and operated within 30 days of receipt.

Type of Warranty Claim

- Failure to follow the furniture instructions will invalidate the warranty. Attention please.
- Does not include damage during installation, but includes damage during transportation.

Scope of responsibility

- Shall not bear any responsibility for misuse or user damage and / or loss of parts during the installation of furniture.
- After using, the damage and scratches of the furniture are not covered by the warranty.

The Warranty Relates to All Bought in The Us and Covers The Following Areas

- Sheet parts: 1 month from the date of purchase.
- Electrical parts: 1 month from the date of purchase.

RETURNS

CHANGED YOUR MIND AND NEED TO RETURN YOU ITEM?

PLEASE FOLLOW THE BELOW INSTRUCTIONS:

- If you have purchased and have simply changed your mind, follow the retailer's instructions for returns.

DEFECTIVE ITEMS

- If your item is defective in any way, i.e. it doesn't work but you can't identify why, in the first instance, please call us.

DAMAGED ITEMS

- If you receive an order with obvious shipping damage from the retailer, then we suggest the delivery is refused. If the delivery has been accepted and then shipping damage is found, please follow the specific instructions advised by the retailer. In all circumstances please save all packaging material and paperwork for the order. Please be aware that if you dispose of packaging material or attempt to return the merchandise without contacting the fulfiller, you jeopardise your chances of making a claim, and you may not receive a credit for the return.

AFTER-SALES CONTACT



feedbackstation@163.com



(303)800-6387