

**ASSEMBLY INSTRUCTIONS**  
**for Changing Table**  
**RILEY**  
**Model # 11466**

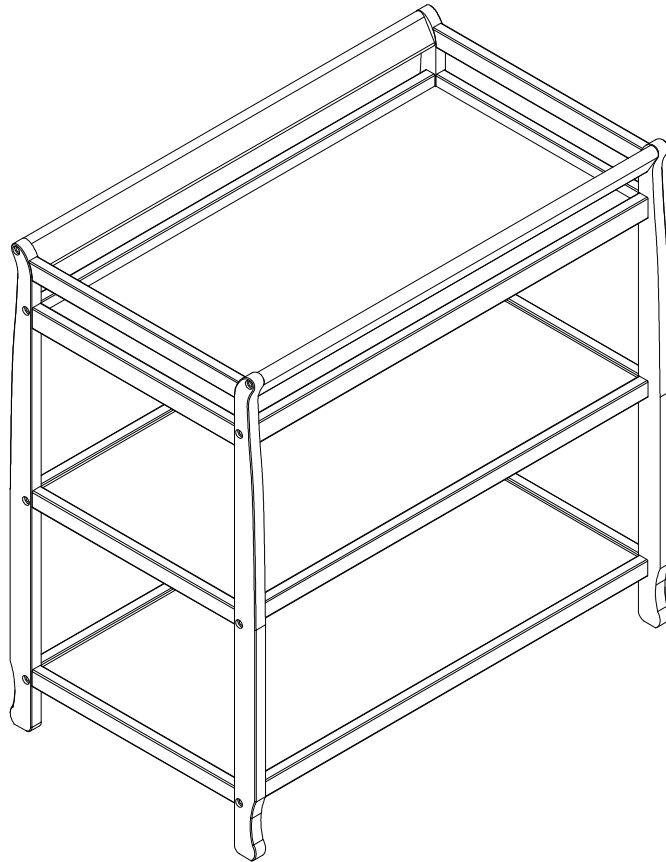

*suitebébé*

**"THE PRODUCT IMAGES SHOWN ARE FOR ILLUSTRATION PURPOSES ONLY AND MAY NOT BE AN EXACT REPRESENTATION OF THE PRODUCT."**

Carefully remove and lay out all parts. Familiarize yourself with all exhibits and diagrams to facilitate the assembly of your Changing table.

**TOOLS REQUIRED :**  
**Allenkey (supplied)**

**PART ENCLOSED IN CARTON**

A .Thick Shelf (Top) (1 pc )

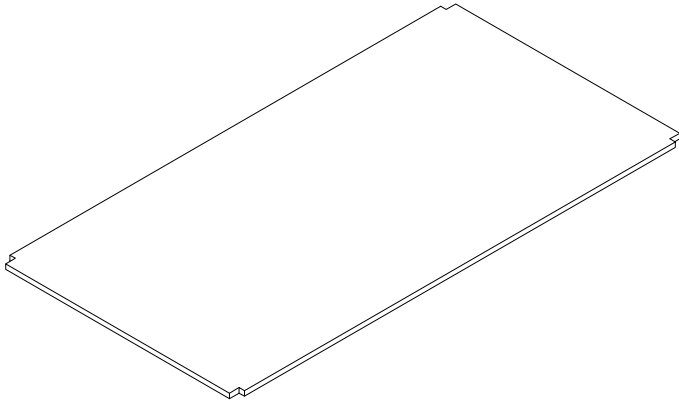

B.Thin Selves (Middle/Bottom) (2 pcs)

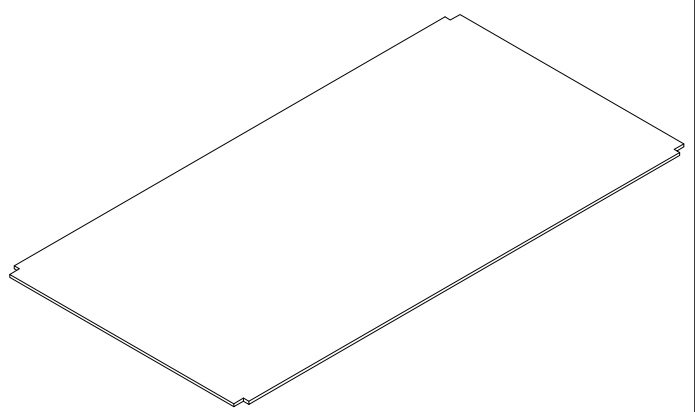

C .Wide grooved rail (Top) (2 pc )

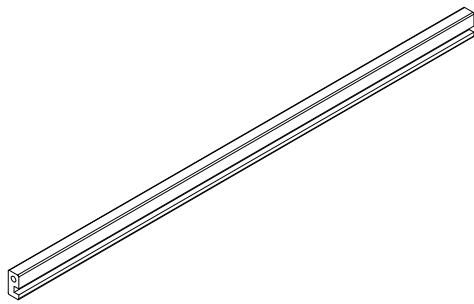

F .Side Board (2 pcs )

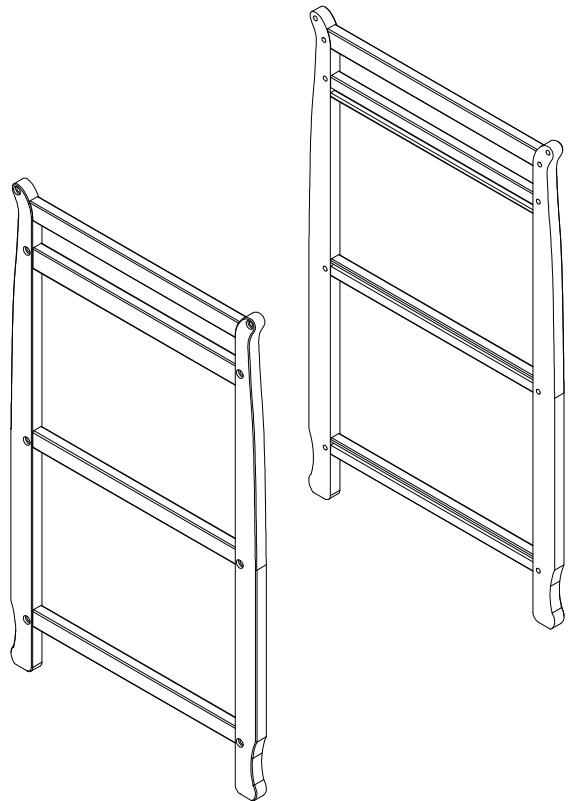

D .Grooved rail (Middle / Bottom) (4 pcs )

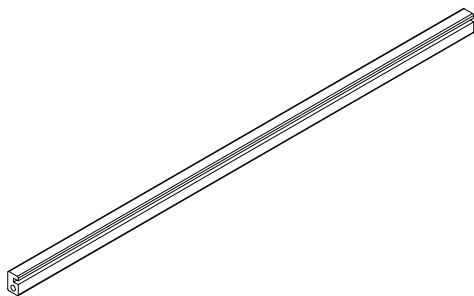

E .Front / Back rail (Top) (2 pcs)

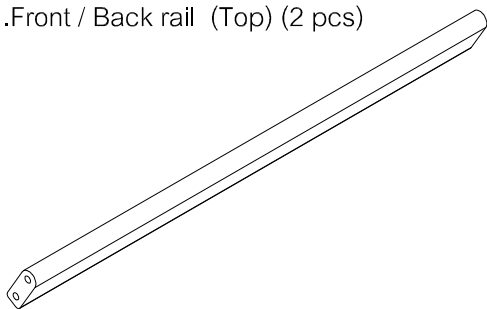

## HARDWARE

H. Allen Bolt 1 3/8" (35 mm) (16 pcs.)

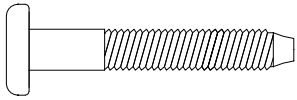

W. Spring Washer (16 pcs.)

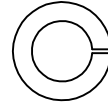

K. Wooden Dowel 1 1/4" [30 mm] (4 pcs)

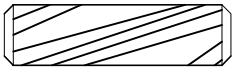

M. Allen Key (1 pc) (length may vary)

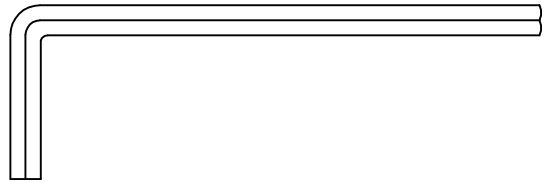

Make sure the bolts are tightly locked against the washers during assembly.  
(Please add an extra 1/2 revolution to all the bolts when using spring washer after tightening)

## STEP 1 " ASSEMBLY OF RAILS "

### THIS STEP REQUIRES :

- C .Wide grooved rail (Top) (2 pcs )
- D .Grooved rail (Middle / Bottom) (4 pcs )
- E .Front/Back rail (Top) (2 pcs )
- F .Side Board (1 pc )

H. Allen Bolt 1 3/8" (35 mm) (8 pcs.)

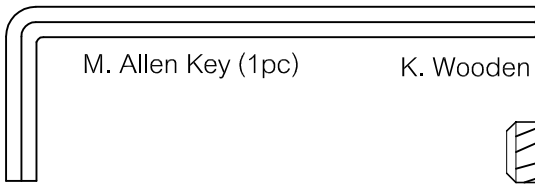
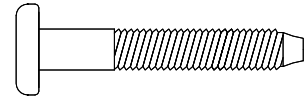

M. Allen Key (1pc)

K. Wooden Dowel 1 1/4" [30 mm] (2 pcs)

W. Spring Washer (8 pcs.)

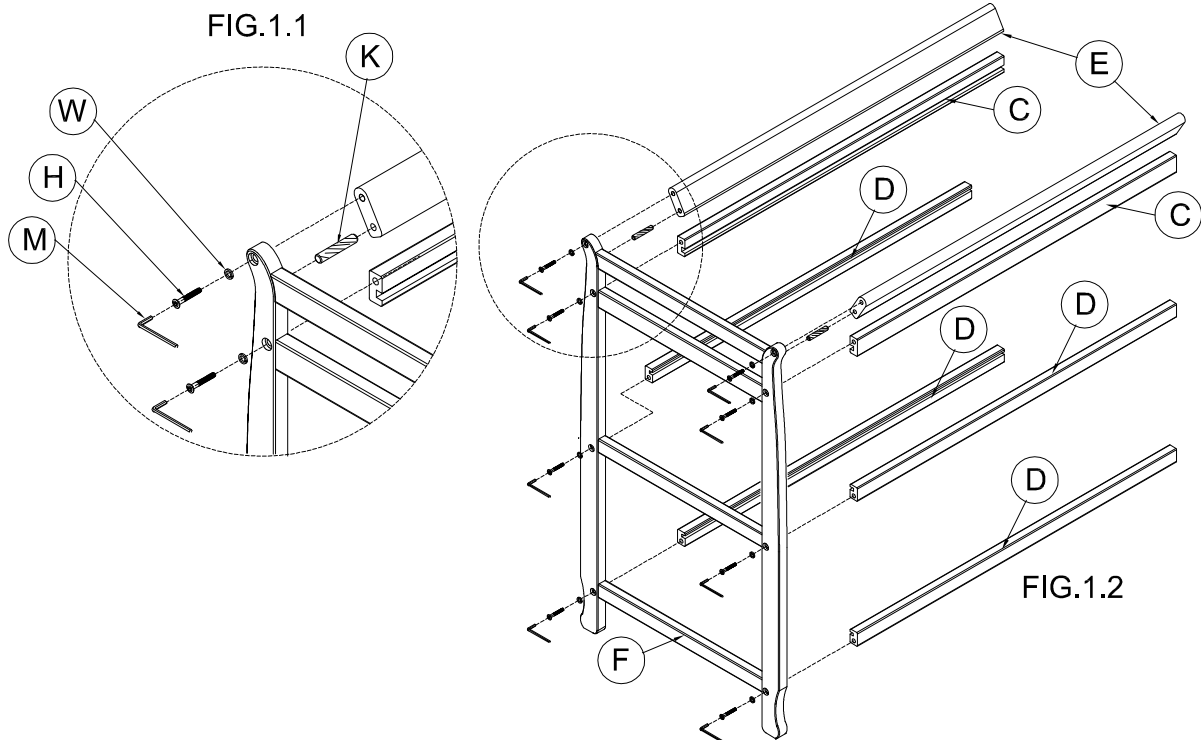
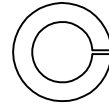

- A. Attach front / back rail (Top) (E) to the top edge of sideboard using allenbolt 1 3/8" (35 mm) (H), spring washer (W) and wooden dowel (K), as shown in figure 1.1.
- B. Attach the two (2) wide grooved rails (Top) (C) to the left and right position on one of the sideboard (F), using allenbolt 1 3/8" (35 mm) and spring washer (W) as shown in figure 1.2.
- C. Attach the four (4) grooved rails (Middle /Bottom)(D) to the left and right position on one of the sideboard (F) using allenbolt 1 3/8" (35 mm) (H) and spring washer (W), as shown in figure 1.2.
- D. Using the Allen Key (M) tighten the Allenbolts (H) as shown in figure 1.2.

## STEP 2 " ASSEMBLY OF SHELVES "

### THIS STEP REQUIRES :

- A.Thick Shelf (Top) (1 pc )
- B.Thin Selves (Middle/Bottom) (2 pcs)

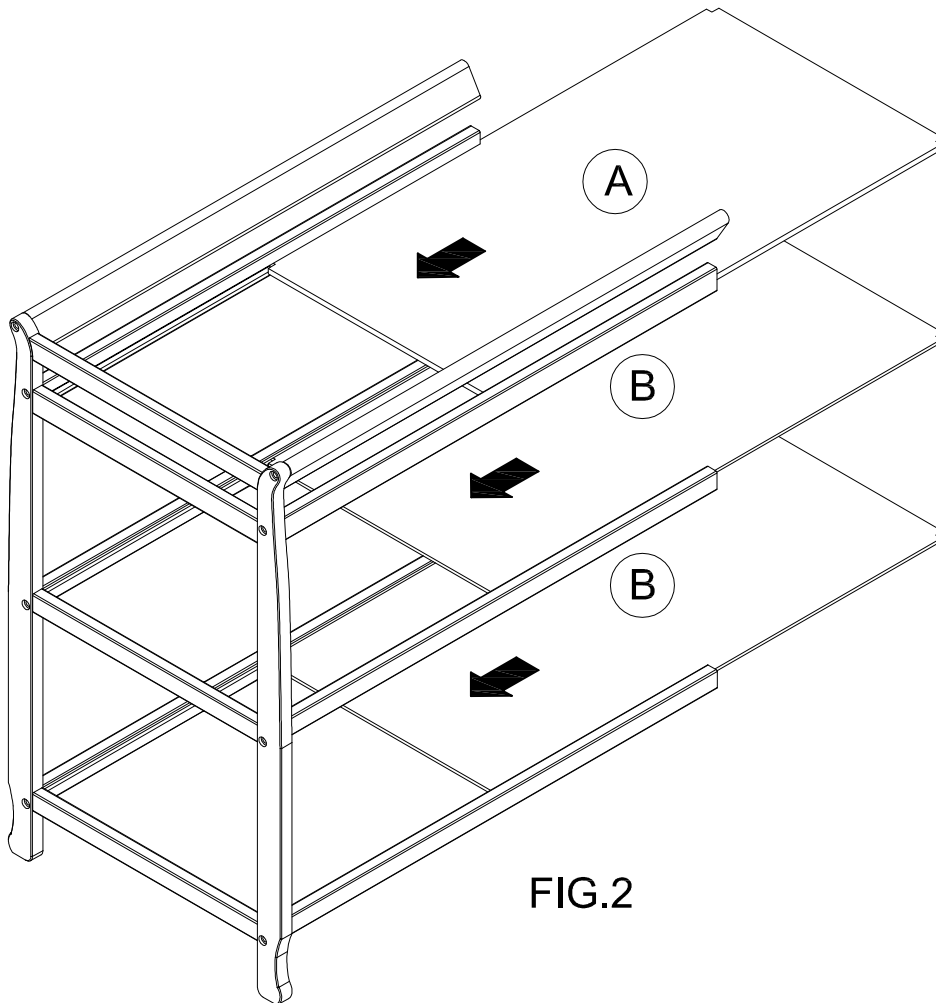

FIG.2

- A.Lay the sideboard on the floor, rails up. Make sure that the thick Shelf (A) is inserted into the Top wide grooved Rails (C). Slide the shelf through the grooves and into the sideboard.
- B. Repeat with the two remaining thin shelves (B), as shown in figure 2.

## STEP 3 " ASSEMBLY OF SIDEBOARD "

### THIS STEP REQUIRES :

F. Side Board (1 pc)

M. Allen Key (1pc)

H. Allen Bolt 1 3/8" (35 mm) (8 pcs.)

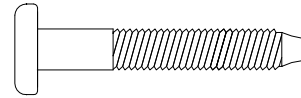

W. Spring Washer (8 pcs.)

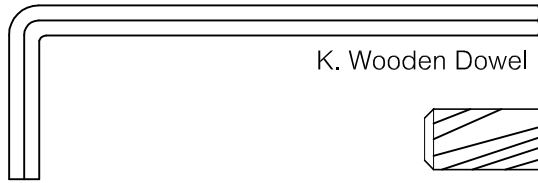
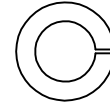

K. Wooden Dowel 1 1/4" [30 mm] (2 pcs)

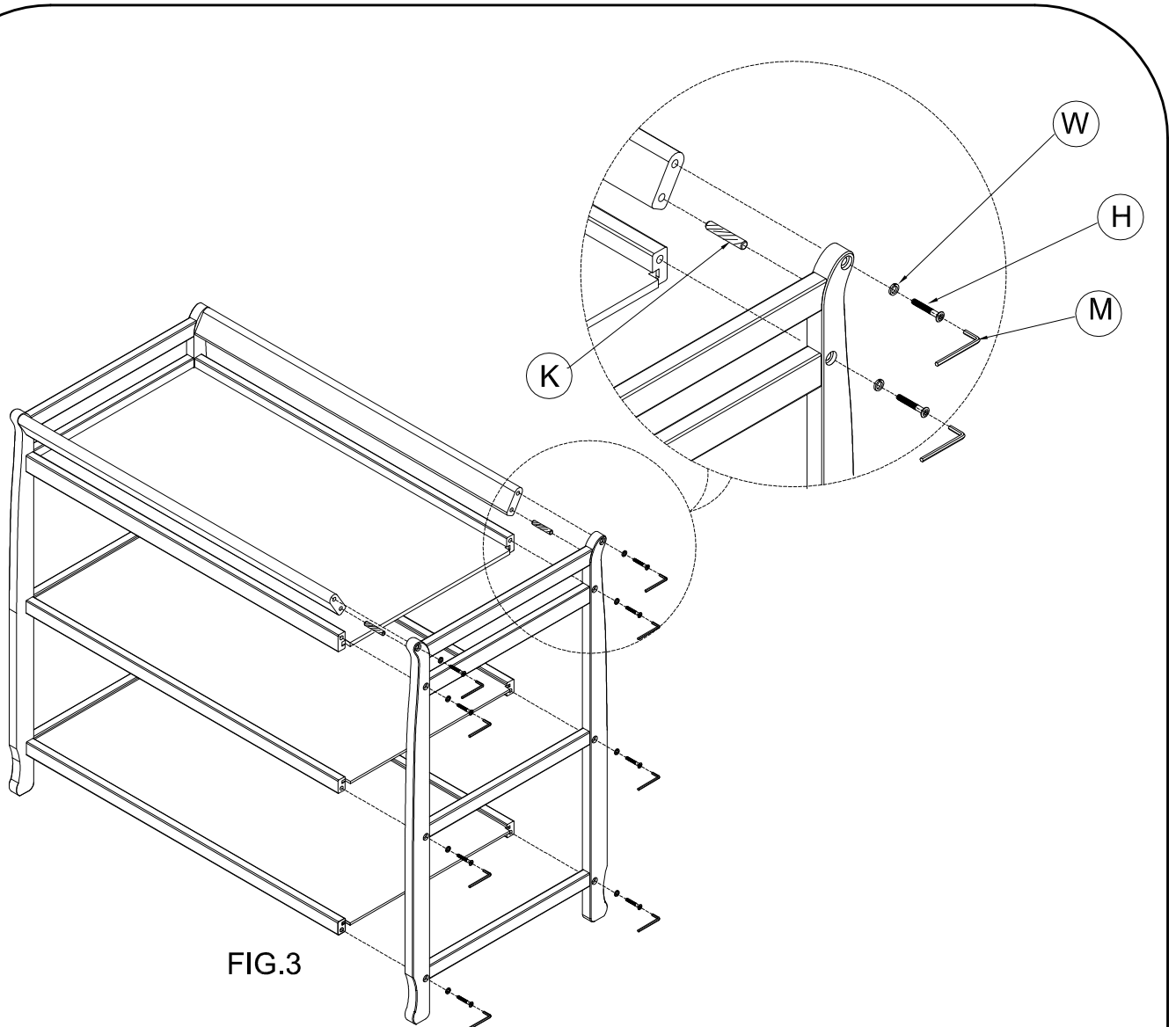
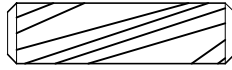



FIG.3

Attach the other sideboard (F) to the rails using allenbolts 1 3/8" (35 mm) (H), spring washer (W) and wooden dowel (K), as shown in figure 3.

Tighten all bolts with the allenkey (M).

 **“CAUTION: ANY PAD USED IN THIS CHANGING TABLE MUST BE AT LEAST 16 INCHES BY 32 INCHES (41 CM X 81 CM) WITH A THICKNESS NOT EXCEEDING 1 INCH (2.54 CM).”**

 **WARNING!** FOR CHANGING TABLE USE

- READ ALL INSTRUCTIONS BEFORE ASSEMBLING CHANGING TABLE.

**KEEP INSTRUCTIONS FOR FUTURE USE.**

- READ ALL INSTRUCTIONS BEFORE USE OF THE CHANGING TABLE.
- FAILURE TO FOLLOW THESE WARNINGS AND THE ASSEMBLY INSTRUCTIONS COULD RESULT IN SERIOUS INJURY OR DEATH.
- **CAUTION** : THE PAD INTENDED FOR USE ON THE CHANGING TABLE SHALL HAVE MINIMUM DIMENSIONS OF 16 INCHES BY 32 INCHES (41 CM X 81 CM) WITH A THICKNESS NOT EXCEEDING 1 INCH (2.54 CM).
- THE MAXIMUM WEIGHT SHALL NOT BE GREATER THAN 30 LB (13.6 KG).
- DO NOT USE CHANGING TABLE IF IT IS DAMAGED OR BROKEN.
- PLEASE CLEAN THE CHANGING TABLE WITH A DRY CLOTH AND USE MILD WOOD POLISH IF REQUIRED.

 **WARNING**

**FALL HAZARD** : CHILDREN HAVE SUFFERED SERIOUS INJURIES AFTER FALLING FROM CHANGING TABLES. FALLS CAN HAPPEN QUICKLY.

- **STAY** IN ARM'S REACH OF YOUR CHILD.
- THE MAXIMUM WEIGHT SHALL NOT BE GREATER THAN 30 LB (13.6 KG).