

ASSEMBLY & INSTRUCTION MANUAL



OFFICE CHAIR

WARNING

Please read the instructions carefully and follow the assembly steps.

To ensure proper assembly, please follow all steps and use all parts provided. Not following this warning may result in serious injury to you or others.

To prevent misalignments, keep the screws loose and do not tighten them until they are all in their correct positions.

Avoid overtightening or forcing the screws, as this could cause them to break, strip, or damage the threads of the holes.

Using the wrong size of screws for a particular part could cause damage to the screw or the part.

Please lubricate all moving parts regularly and tighten all bolts and screws every 6 months, or as needed.

SAFETY INFORMATION

WEIGHT CAPACITY FOR SEATING: 300LBS (≈136KG)



Sit in the center of the chair with your back against the backrest



Do not sit at the front edge of the chair



Do not stand on the chair



Do not use the chair with more than one person



Do not push the chair around when a person is sitting in it



Do not push down on the backrest when a person is reclined



Do not place all your weight on the backrest only

ASSEMBLY PARTS AND TOOL

PLEASE MAKE SURE ALL THE PARTS ARE INCLUDED.

A



Star Base *1

B

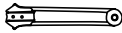

Base Legs *5

C



Casters *5

D



Gas Lift Cover *1

E

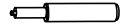

Gas Lift *1

F



Seat Cushion *1

G



Seat Plate *1

H



Back Cushion *1

I



Steel Plate *1

J



Armrests *2

K



M6x12mm Bolts *10

L



M6x20mm Bolts *4

M



M6x25mm Bolts *4

N



M8x20mm Bolts *4

O



M8x40mm Bolts *4

P



Plastic Cap *4

Q



Wrench *1



BEFORE YOU GET STARTED, A FEW POINTERS:



Having a friend to help makes assembly extra-easy.



Please use the included wrench instead of an ELECTRIC HAND DRILL in case of damage to the product.

ASSEMBLY INSTRUCTIONS

STEP 1 Connect Star Base (A) and Base Legs (B) with TEN Bolts (K), using the Wrench (Q).

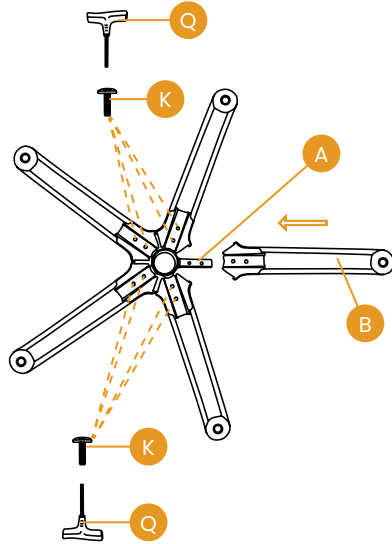

STEP 2 Press the Casters (C) into the holes at the end of each base leg, Then put on the Star Base Cover (D) and insert the Gas Lift (E) into the center hole of the Star Base (A).

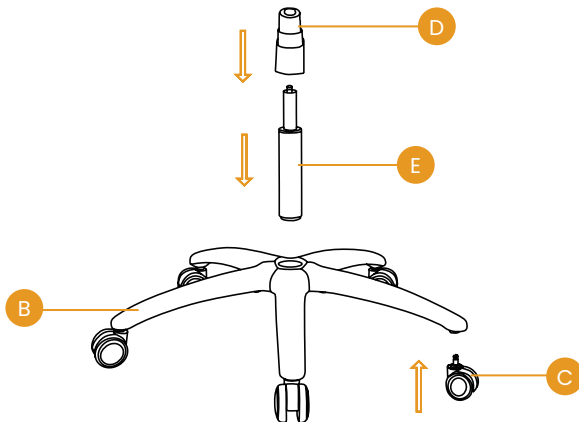

ASSEMBLY INSTRUCTIONS

- STEP 3** Align the Seat Plate (G) over the pre-drilled holes underneath the Seat Cushion (F), make sure that the front of the Seat Plate is facing the front of the Seat Cushion. Attach the Seat Plate (G) to the Seat Cushion (F) using FOUR Bolts (L), tighten all the bolts with the Wrench (Q), being careful not to miss-thread the bolts or damaged the Seat.

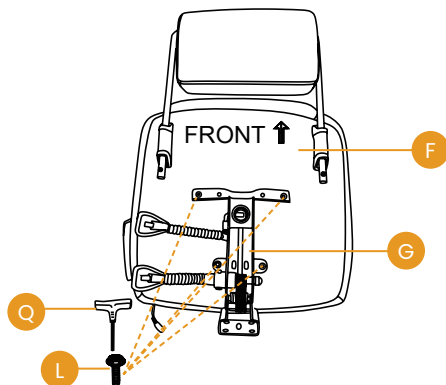

- STEP 4** Turn the Seat Cushion (F) upright and align the center hole of the Seat Plate (G) over the Gas Lift (E), then push the Seat Cushion (F) down onto the Gas Lift (E) firmly until the connection is secure.

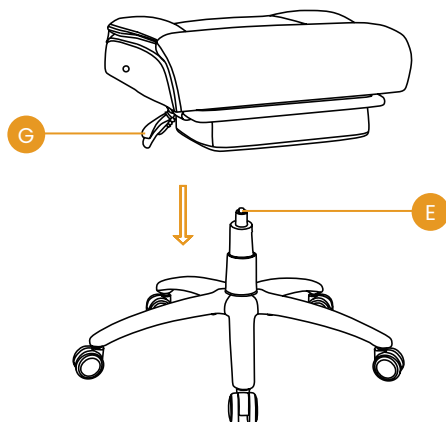

ASSEMBLY INSTRUCTIONS

- STEP 5** Attach the Steel Plate (I) to the Back Cushion (H) with FOUR Bolts (M), using the Wrench (Q).
 Note: The side of the Steel Plate (I) that has the "outside" sign should face the outer side of the chair back.

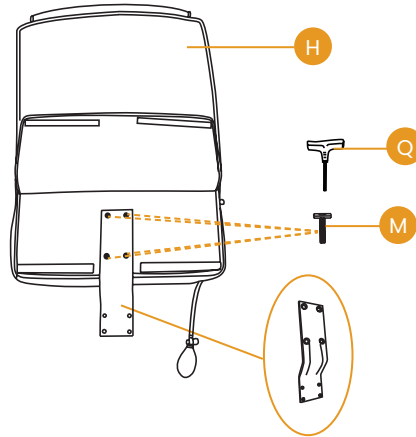

- STEP 6** Insert the Steel Plate (I) into the mechanism to connect Seat Cushion (F) and Back Cushion (H), using Four Bolts (N) and tighten by Wrench (Q) to 50% at first. After Four screws are all aligned, fully tighten the bolts.

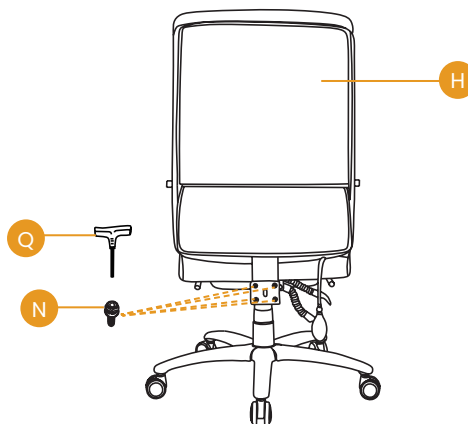

ASSEMBLY INSTRUCTIONS

- STEP 7** Attach the Armrests (J) to the Seat Cushion (F) and Back Cushion (H) with FOUR Bolts (O), using the Wrench (Q).

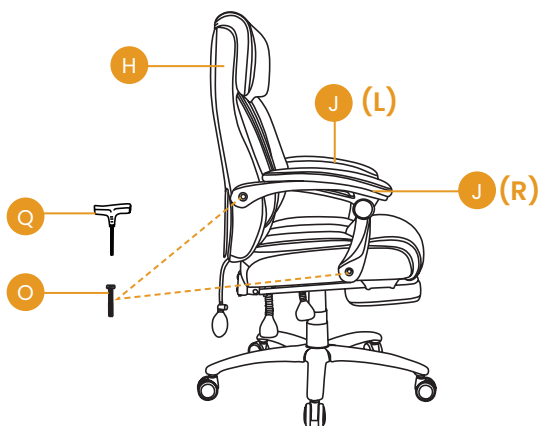

- STEP 8** Use the Plastic Caps (P) to cover the bolt holes on the Armrests.

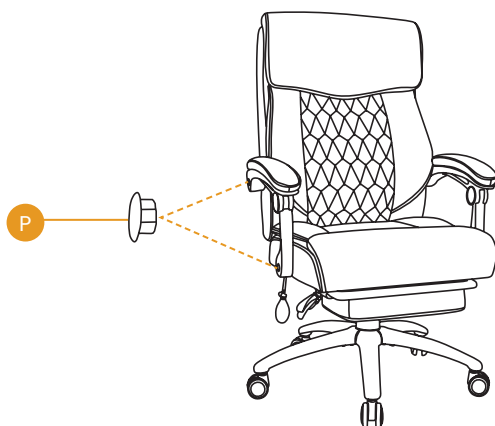

ASSEMBLY INSTRUCTIONS

STEP 9 Now, your chair is successfully installed.



PRODUCT FEATURES

Pneumatic Seat Height Adjustment

Pulling the lever upwards enables height adjustment of the seat, then the seat can be locked at a fixed height by releasing the lever.

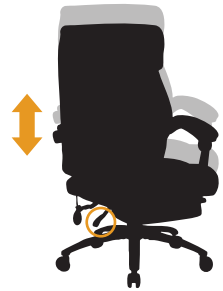

Tilt Angle Adjustment

Simply pull up the lever and recline back to adjust the tilt angle and push down to lock the backrest.



Inflatable Back Cushion

Simply press the airbag to inflate the back cushion and press the deflate button to retract the back cushion.

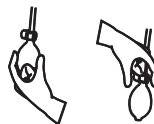

LIMITED WARRANTY

We promise to repair or replace any chair that is found to be defective in material or workmanship within one year from the date of original purchase, as long as you, the original purchaser, still own it. This is your sole and exclusive remedy under this warranty, subject to the provisions outlined below.

EXCLUSIONS

This warranty does not apply to, and no other warranty applies to:

- Normal wear and tear, which is to be expected over the course of ownership.
- Misuse, abuse, or excessive use of the product.
- Modifications or attachments to the product that are not approved.
- Products that were not installed, used, or maintained in accordance with the product instructions and warnings.
- Products used for rental purposes or unauthorized retail activities.

Seating Usage: Normal use for seating is defined as equivalent to a single shift, forty-hour (40) workweek. If the seating product is used in a manner exceeding this, the applicable warranty period will be proportionately reduced.

RETURN POLICY

We offer a 30-day return policy, meaning that all products purchased may be returned to us within that timeframe. You must contact us via email or customer service phone number within 30 days of receiving the product(s), and they must be returned to us without any undue delays.

CONDITIONS:

- Returned products must be in the same condition as received and returned in their original packaging.
- If the product is not faulty (i.e., if you change your mind or are unhappy with the product for another reason), you are responsible for the cost of return shipping. You must ensure the package arrives safely to us, so we recommend using a courier service that offers tracking.

LIMITED WARRANTY

- If the product is faulty when received, please contact us, and we will assist you with the return, covering the shipping costs in this case.
- We reserve the right to offer partial refunds for returned products that are not in unused condition, are damaged, or have missing parts not due to our error.

HOW RETURNS WORK

To request a return, please attach a copy of your invoice as proof of purchase, along with the reason for the return.

We will provide the return address for the product as soon as possible. Once the returned product is received and inspected, we will provide a specific resolution.

If the return is approved, the refund amount will be automatically credited to your original payment method.

MAINTENANCE INSTRUCTIONS



Dust and clean up spills immediately using a clean, non-colored, lint-free cloth.



Use a mild soap solution and a damp cloth to remove stains.



Do not place hot items directly on the furniture surface without using a protective barrier.



For indoor use only. Do not place the furniture outside.



Do not place furniture in direct sunlight.



Do not write on the furniture surface without a padded barrier to protect it.



Do not clean furniture with harsh cleaners or polishes.



Do not place furniture near heating or cooling vents (keep at least 3 feet away).