

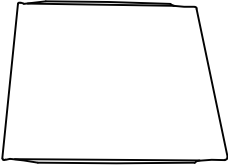







# Assembly Instruction

## PART LIST

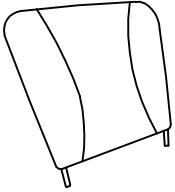
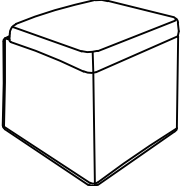
<p>Ax2</p> 	<p>Bx2</p> 	<p>Cx1</p> 	<p>Dx1</p> 	<p>Ex1</p> 	
<p>Fx1</p> 	<p>Gx4</p> 	<p>Hx2</p>  <p>M6*45mm screw</p>	<p>Ix4</p>  <p>M6*20mm screw</p>	<p>Jx14</p>  <p>M6*12mm screw</p>	<p>Kx1</p>  <p>Allen Wrench</p>

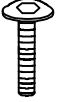
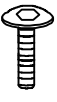
### STEP 1

Note: The holes on the side panels (A\*2) and the rear legs(D) must be on the same side.

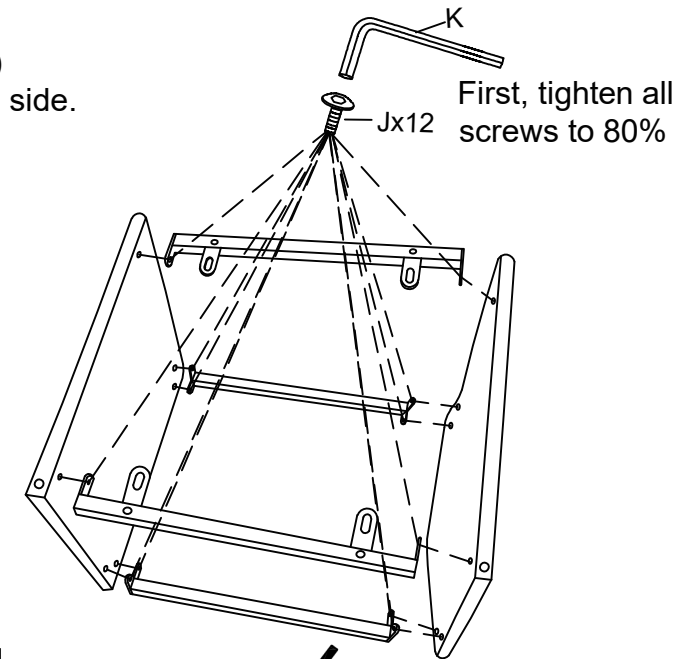
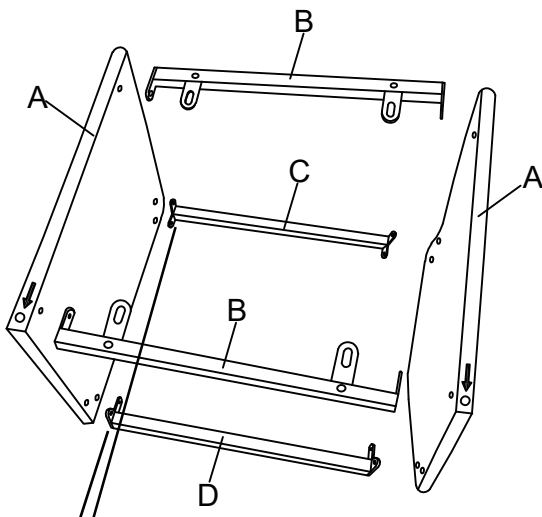

align hole A with holes CD,  
then insert the screw

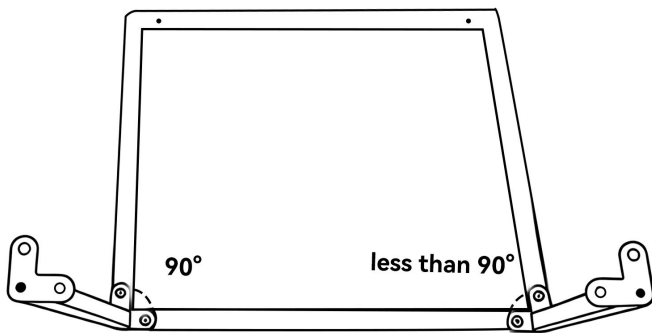

C:front legs

D:hind legs

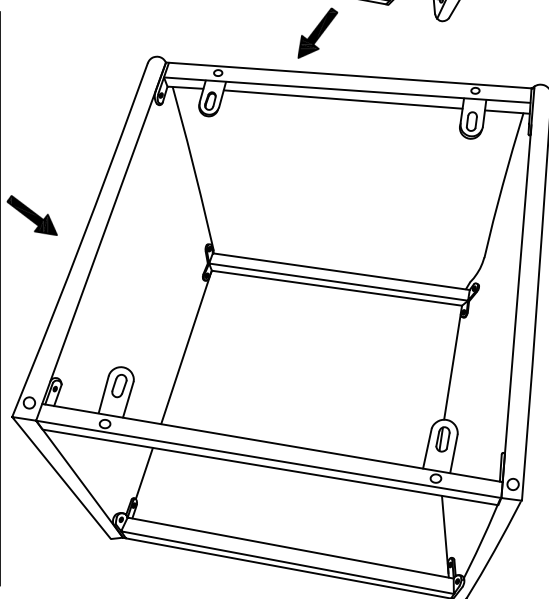

then tighten them all together in the end.

STEP 2

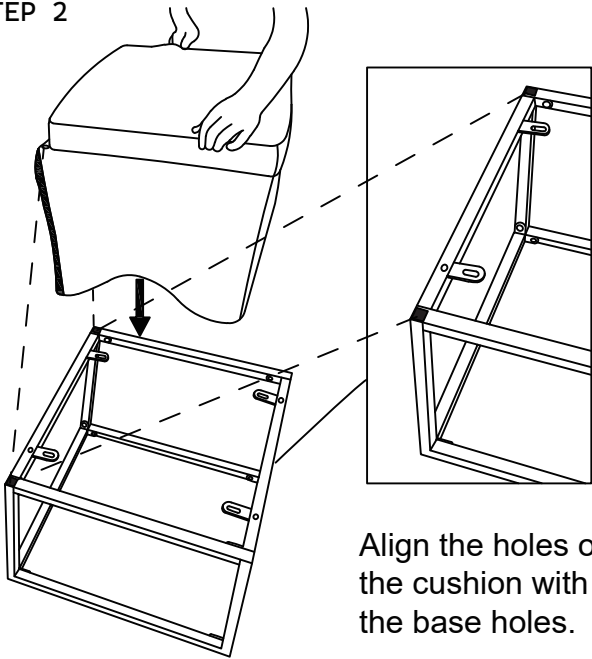

Align the holes of the cushion with the base holes.

STEP 3

First, turn the chair sideways, then tighten all screws to 80%.

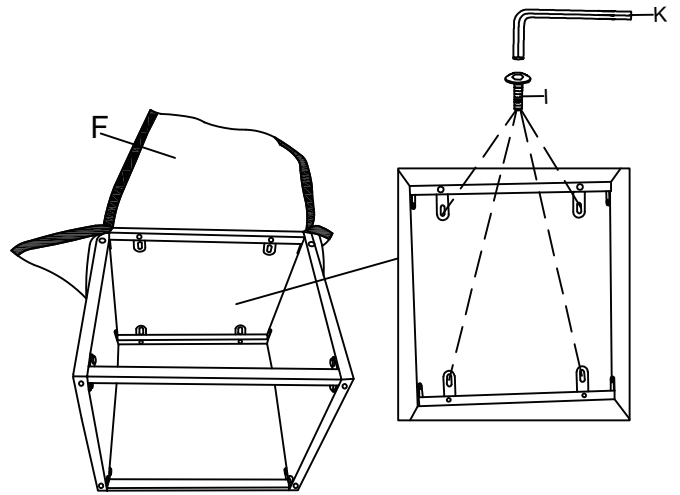

STEP 4

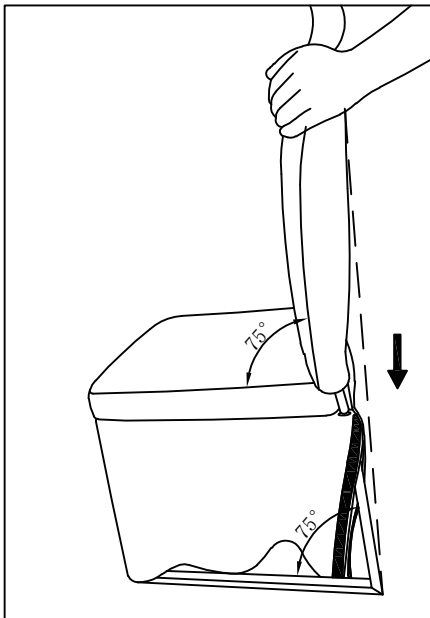

Align the backrest and the base at the same angle (tilt forward 75°), then insert the two steel tubes of the backrest into the corresponding holes on the base.

Note : If it doesn't align, you can adjust the seat cushion.

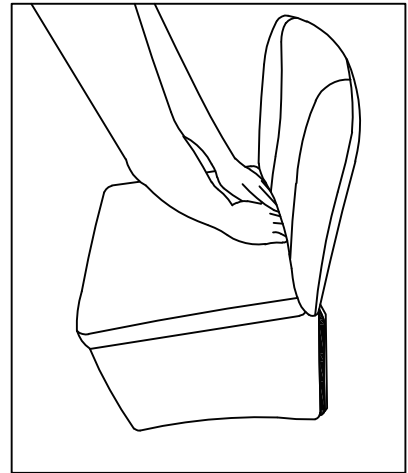

flatten and arrange the cushion foam.

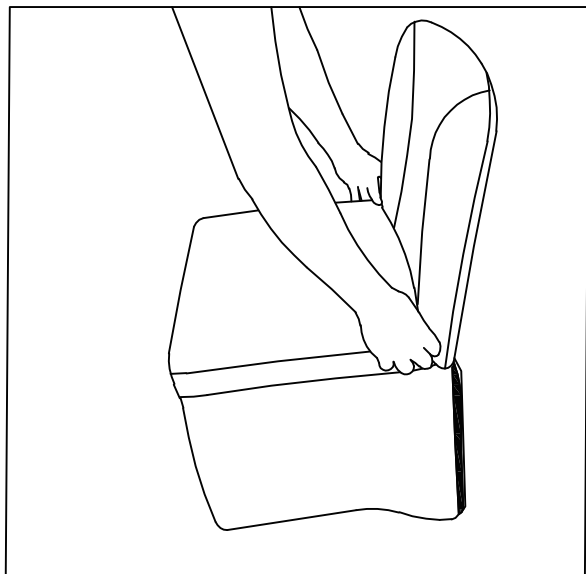

STEP 5

The holes in the chair's backrest and those in the base need to be aligned. tighten all screws to 80%.

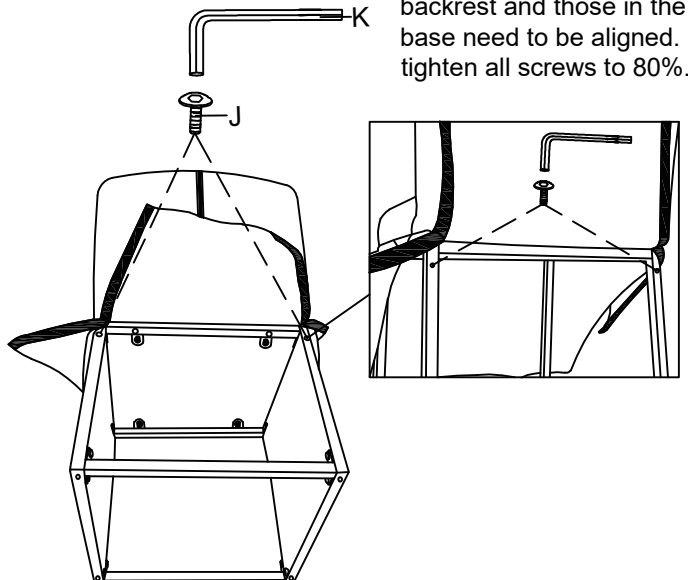

STEP 6

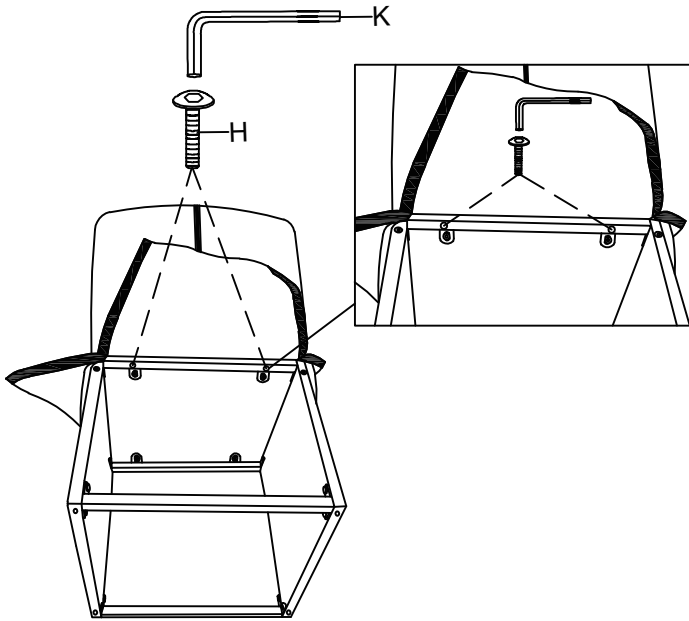

STEP 7

then tighten them all together in the end.

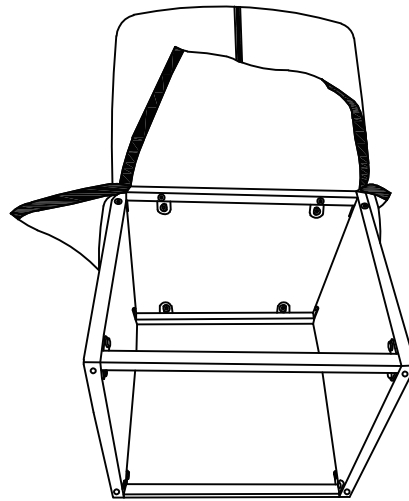

STEP 8

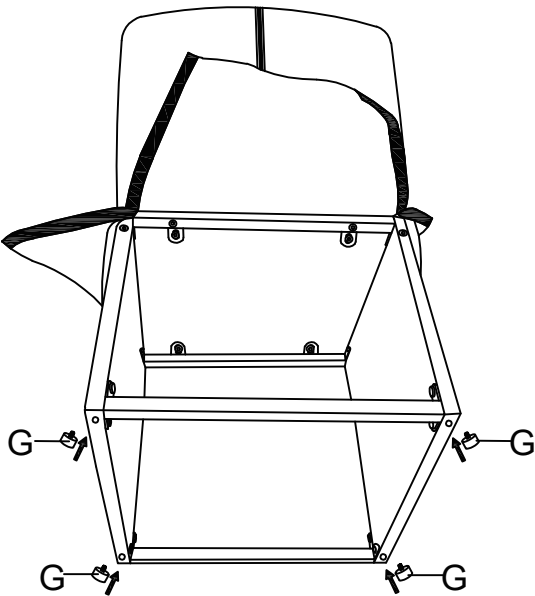

STEP 9

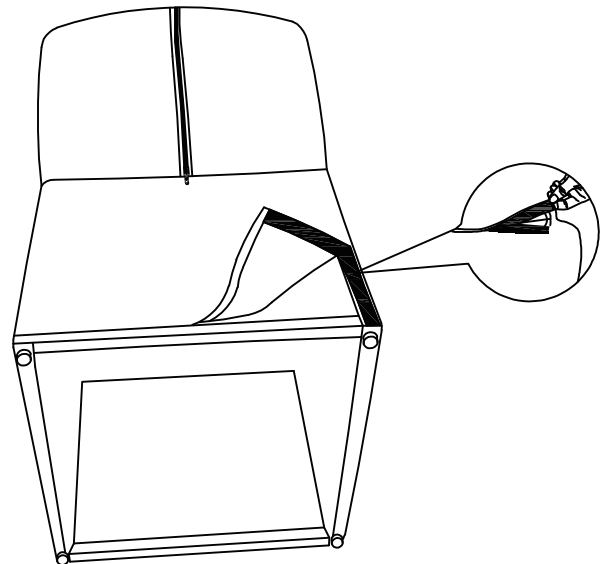

STEP 10

If you find the chair wobbling: Please loosen the 8 screws by 20%, then press the chair down until it is firmly against the ground, and finally tighten the screws again.

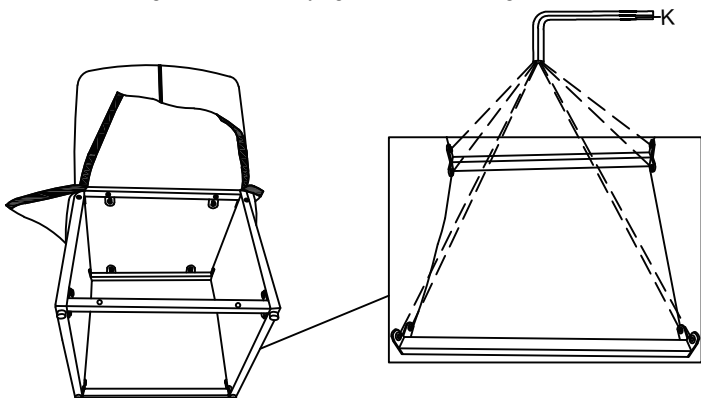

STEP 11

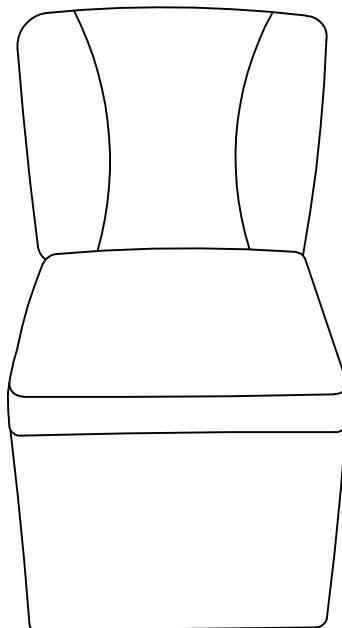

STEP 12

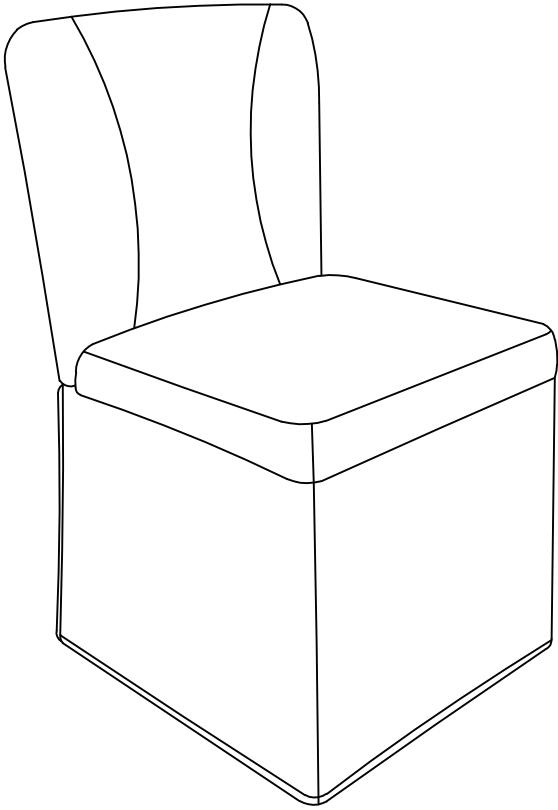

STEP 13

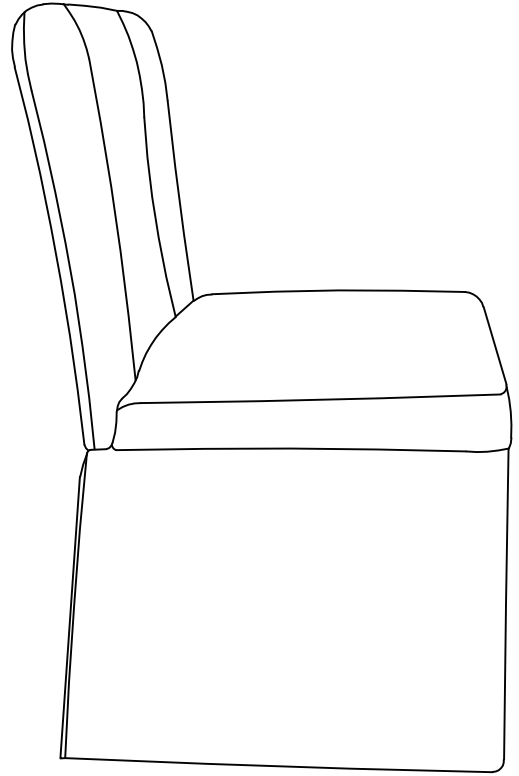

STEP 14

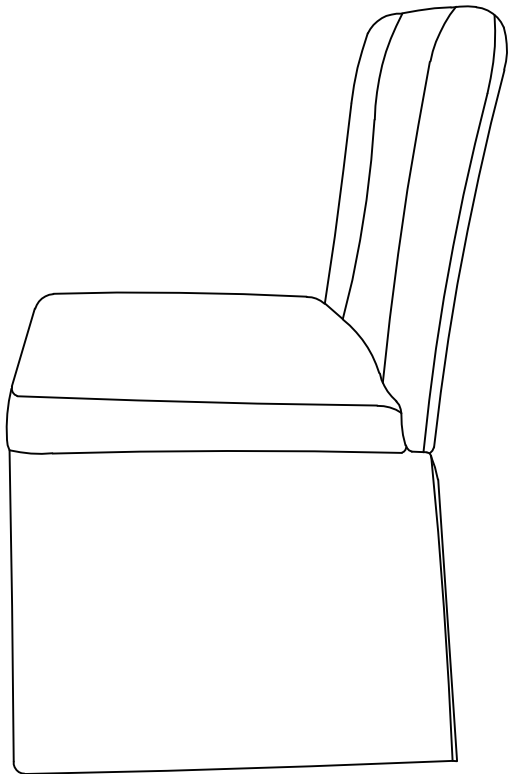

STEP 15

