

Assembly Instructions

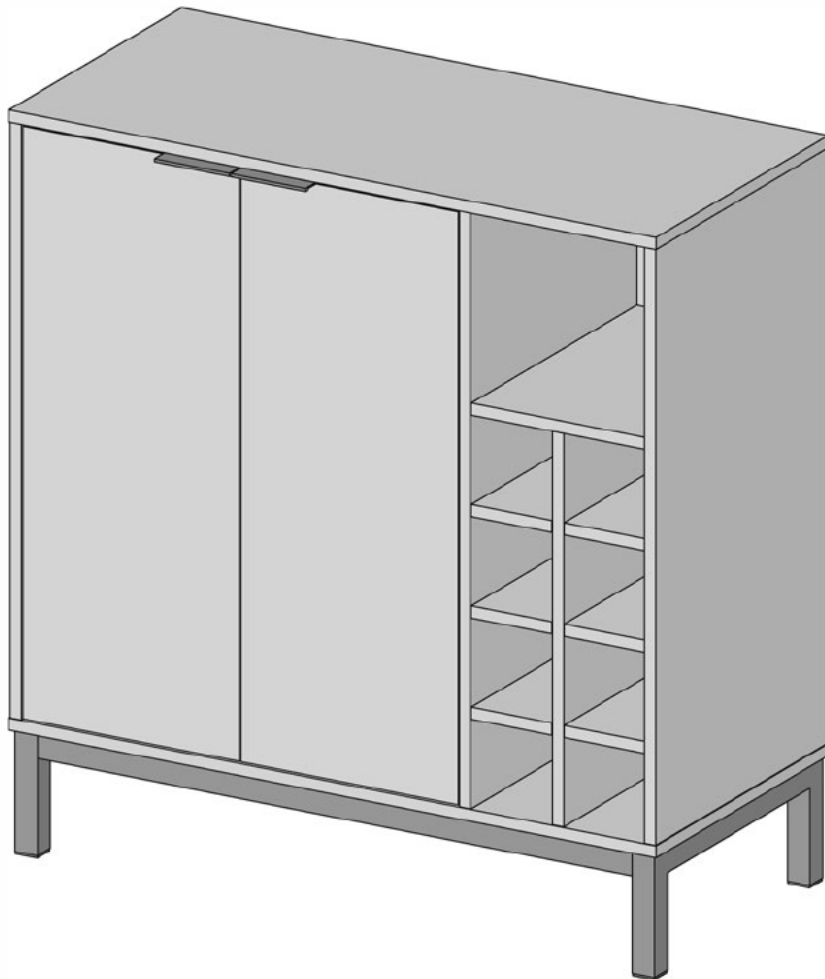

Revised 07/2017

General Assembly Guidelines

- I. Ensure that all parts and hardware are available before beginning assembly.
- II. Follow each step carefully to ensure the proper assembly of this product.
- III. Two people are recommended for ease in the assembly of this product.
- IV. The three main types of hardware used to assemble this product are : wood dowels , screws and bolts.
- V. The provided glue is to secure wood dowels in place . When first inserting dowels , locate the appropriate hole for the dowel , place a small amount of glue in the hole and insert the dowel . Wipe away excess glue immediately.

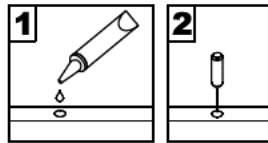

In future assembly steps when dowels are necessary to attach assembly parts together , place a small amount of glue on the end of the dowel before attaching parts together . Wipe away excess glue immediately.



- VI. A Phillips head screwdriver is required for the assembly of this product .

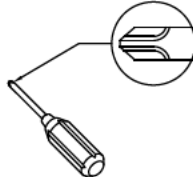

- VII. Power tools should not be used to assemble this product .

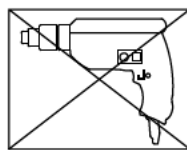

- VIII. Concealed hinges are three-way adjustable.

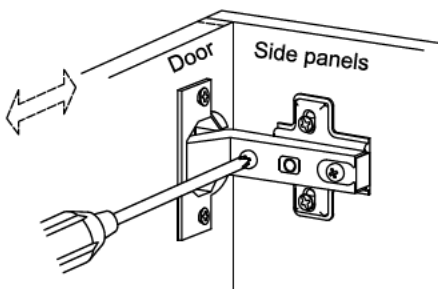

Horizontal
by screw adjustment

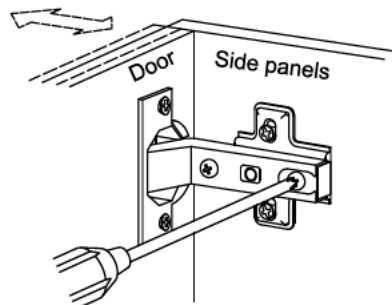

In-and-Out
by loosening the hinge-arm
mounting screw or via cam
adjustment

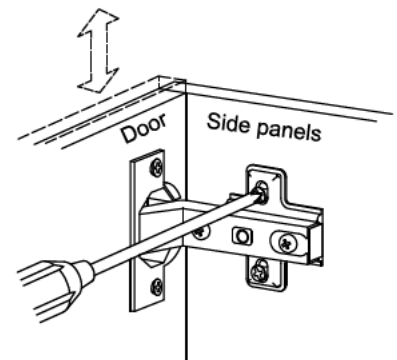





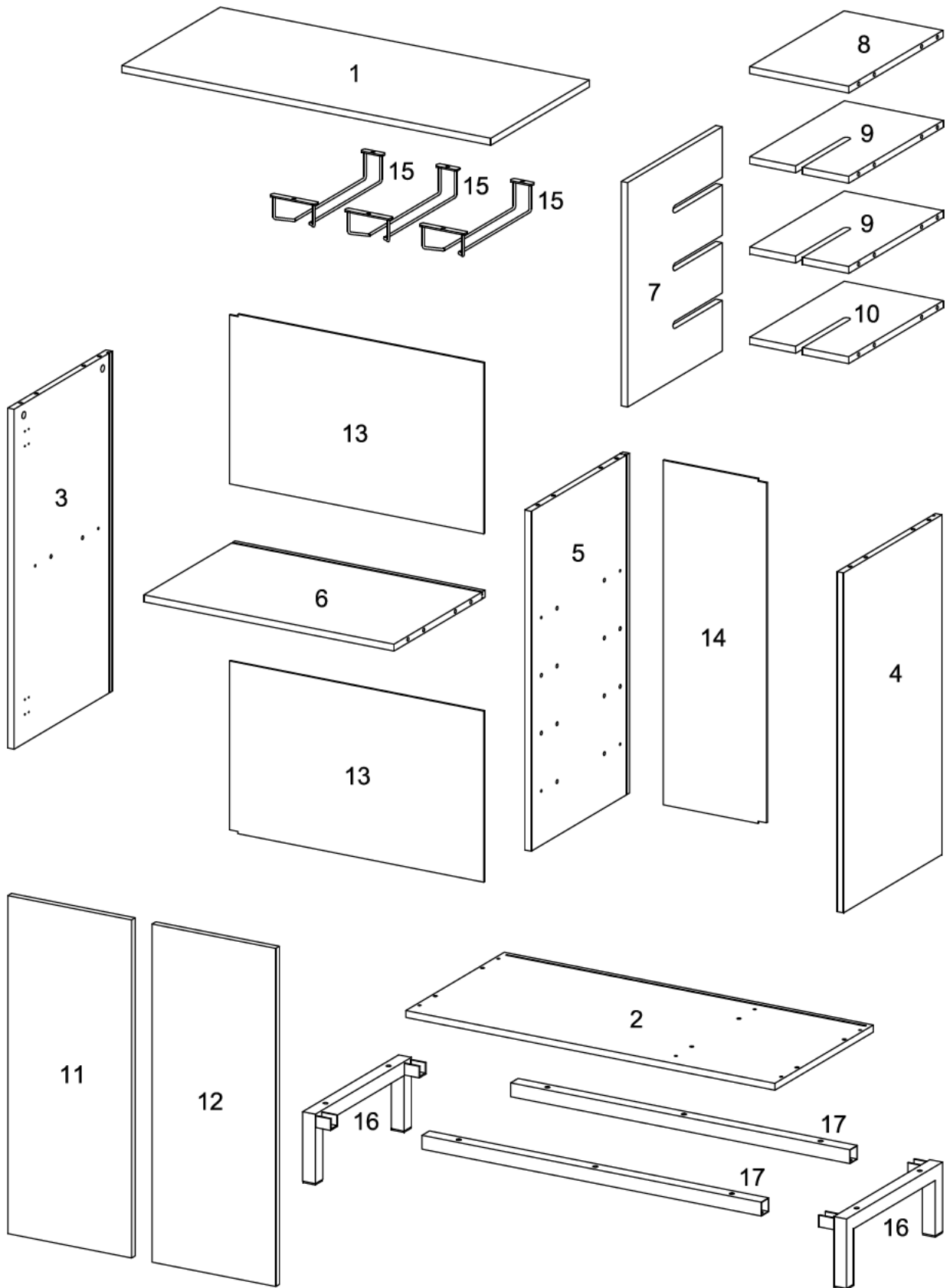



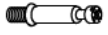

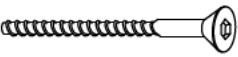
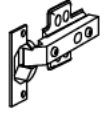

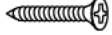

Vertical
Via slots in the mounting
plate or via cam adjustment

Parts List



Hardware List

A		Ø8x30mm	Wooden dowel	40 pcs
B		Ø6x35mm	Cam bolt	18 pcs
C		Ø15x11mm	Cam lock	18 pcs
D		Ø6x50mm	Bolt	6 pcs
E			Hinge	4 pcs
F		Ø3.5x14mm	Screw	30 pcs
G		Ø6x40mm	Bolt	10 pcs
H		Ø6x12mm	Bolt	8 pcs
J		M6x16mm	Washer	18 pcs
K			Plastic wedges	14 pcs
L		Ø3x17mm	Screw	14 pcs
M			Handle	2 pcs
N		Ø3x12mm	Screw	4 pcs
P		Ø30mm	Sticker	18 pcs
Q		M4mm	Wrench	1 pc
R			Glue tube	2 pcs

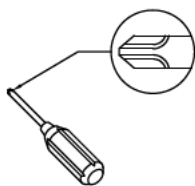

Philips head screwdriver required for assembly
(not included)

*The hardware quantities listed above are required for proper assembly.
Some extra hardware may also have been included.*

Step 1

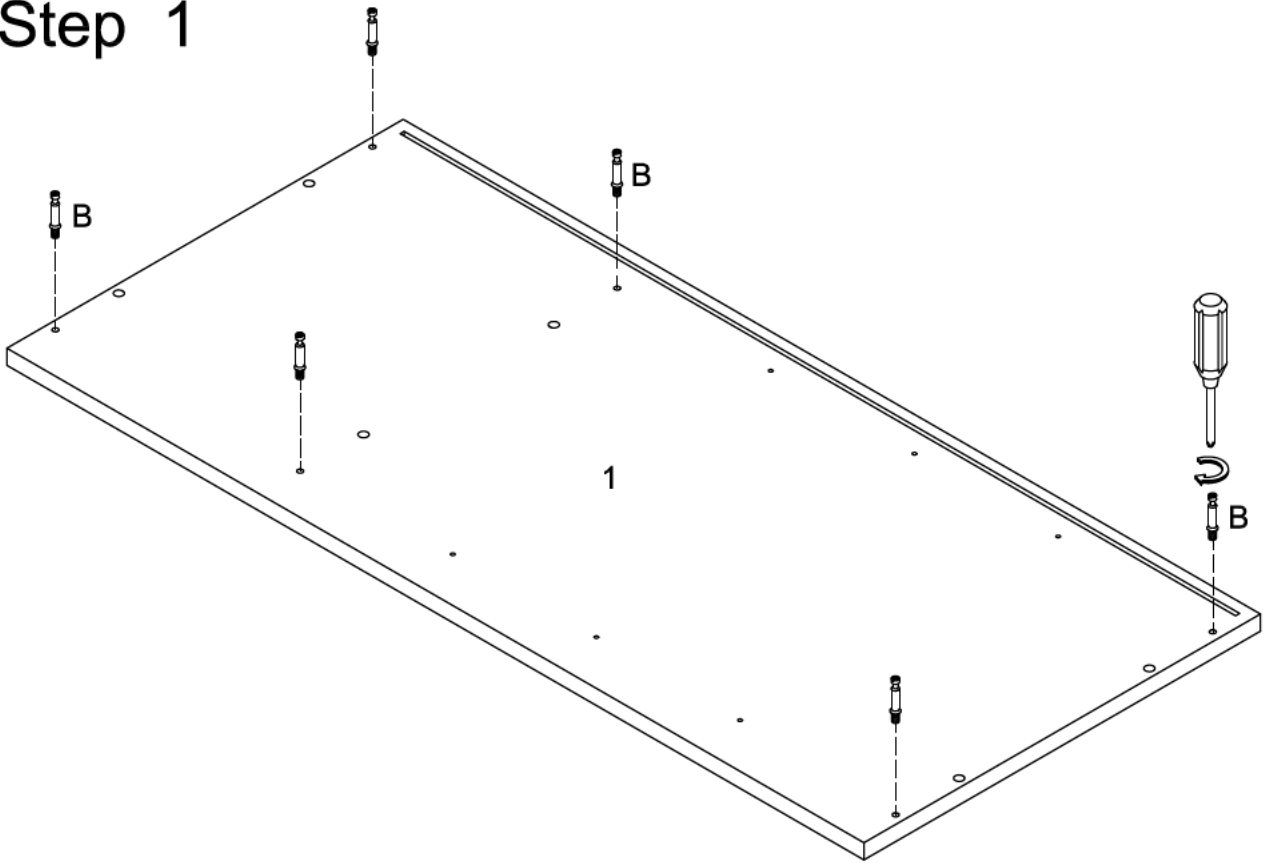

Step 2

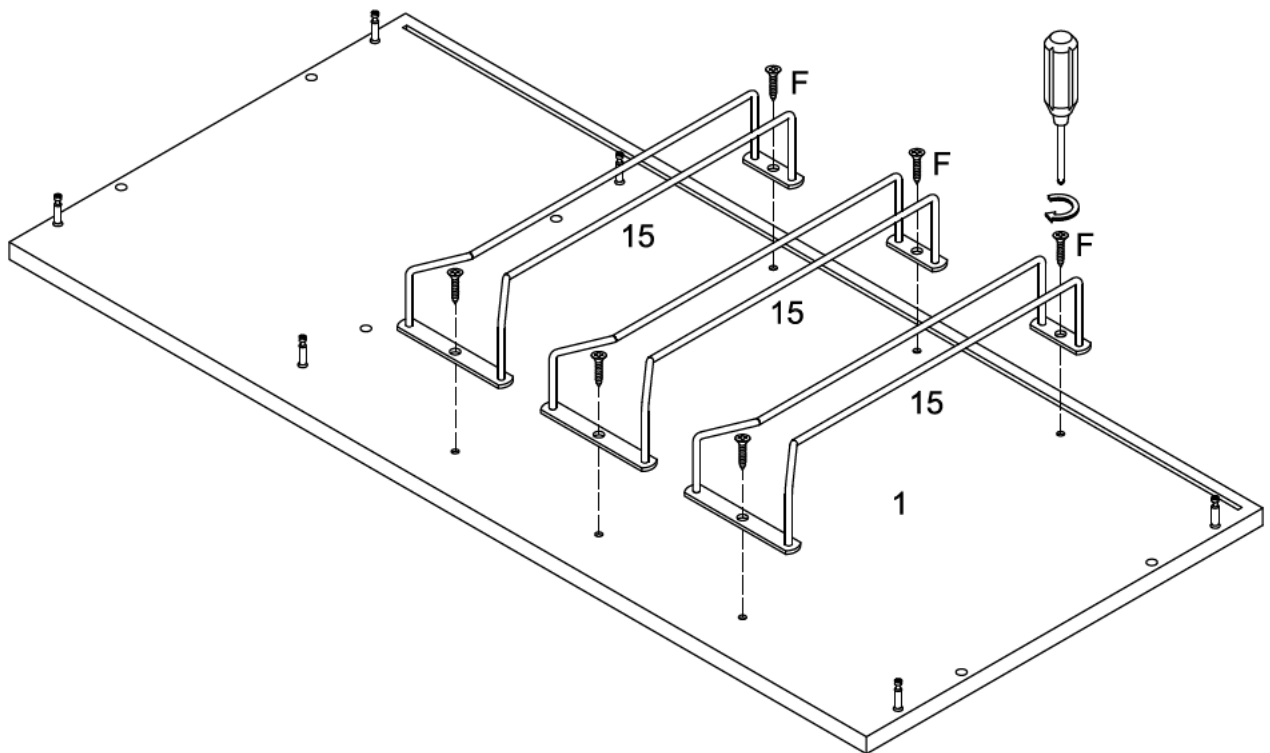

Step 3

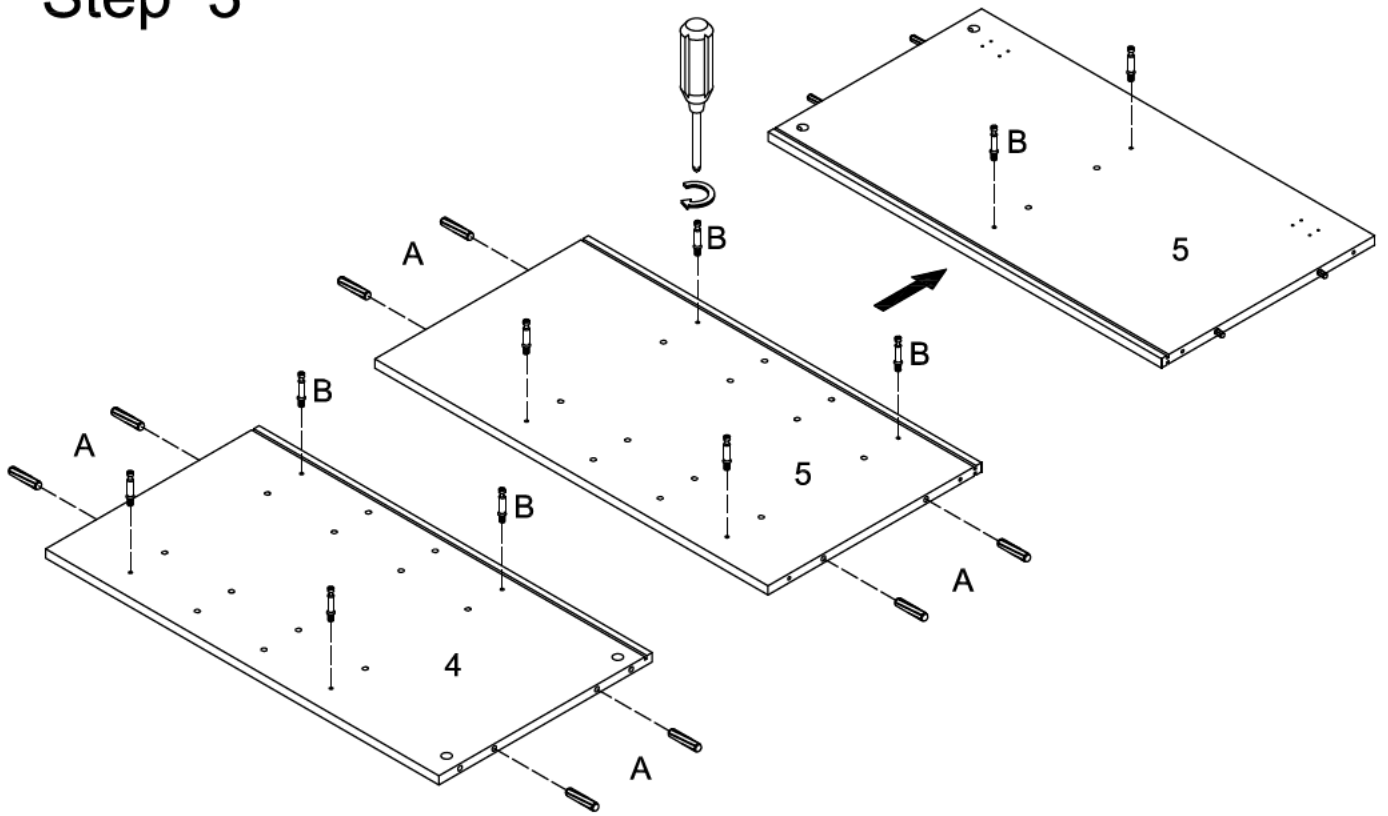

Step 4

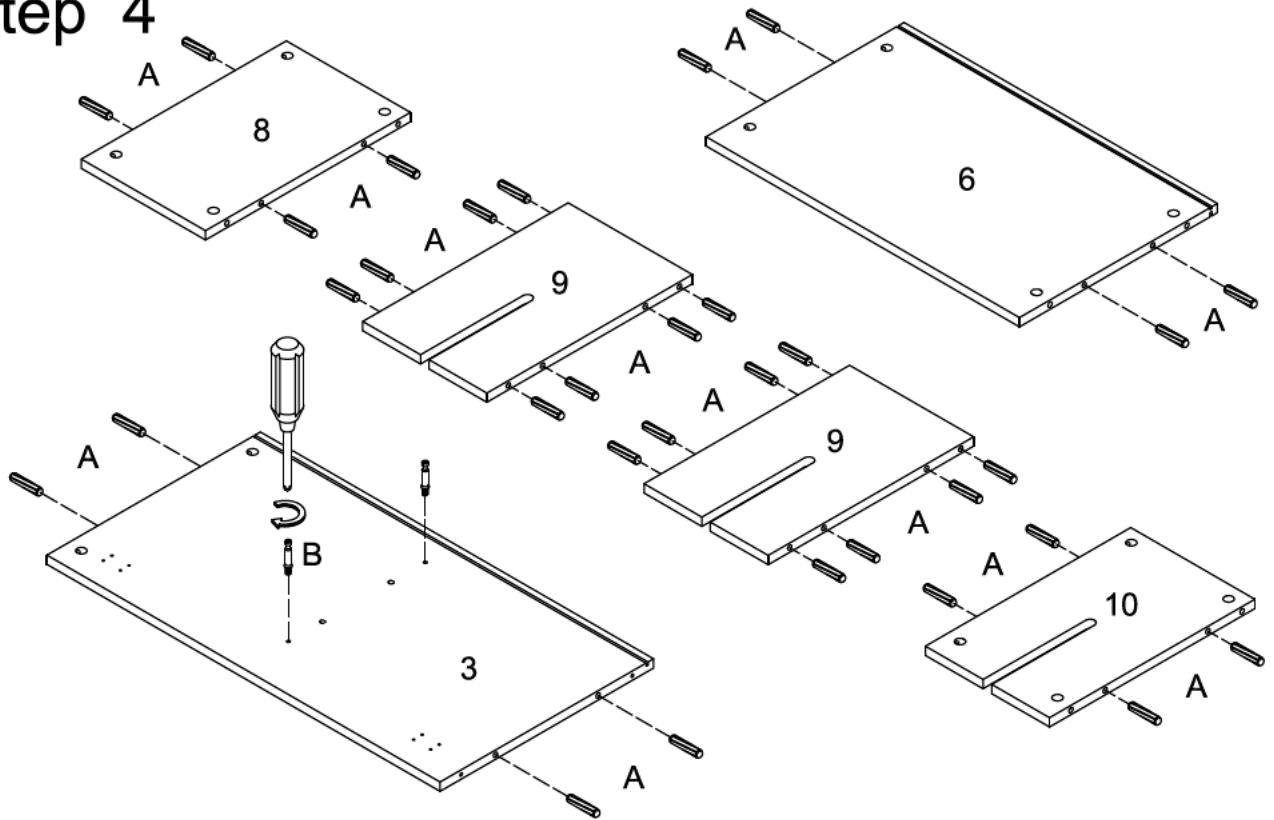

Step 5

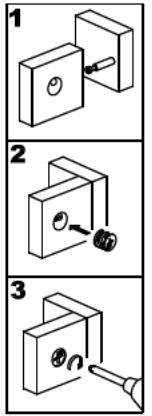
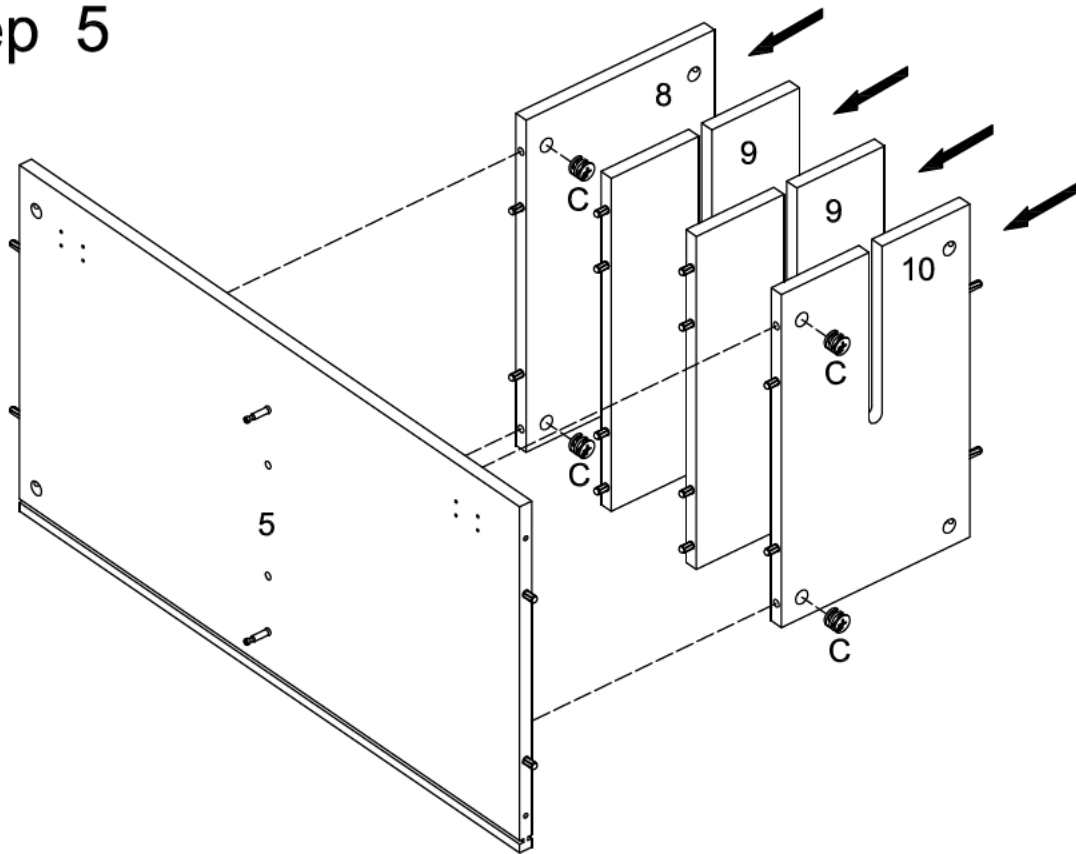

Step 6

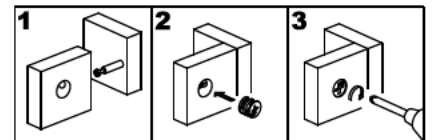
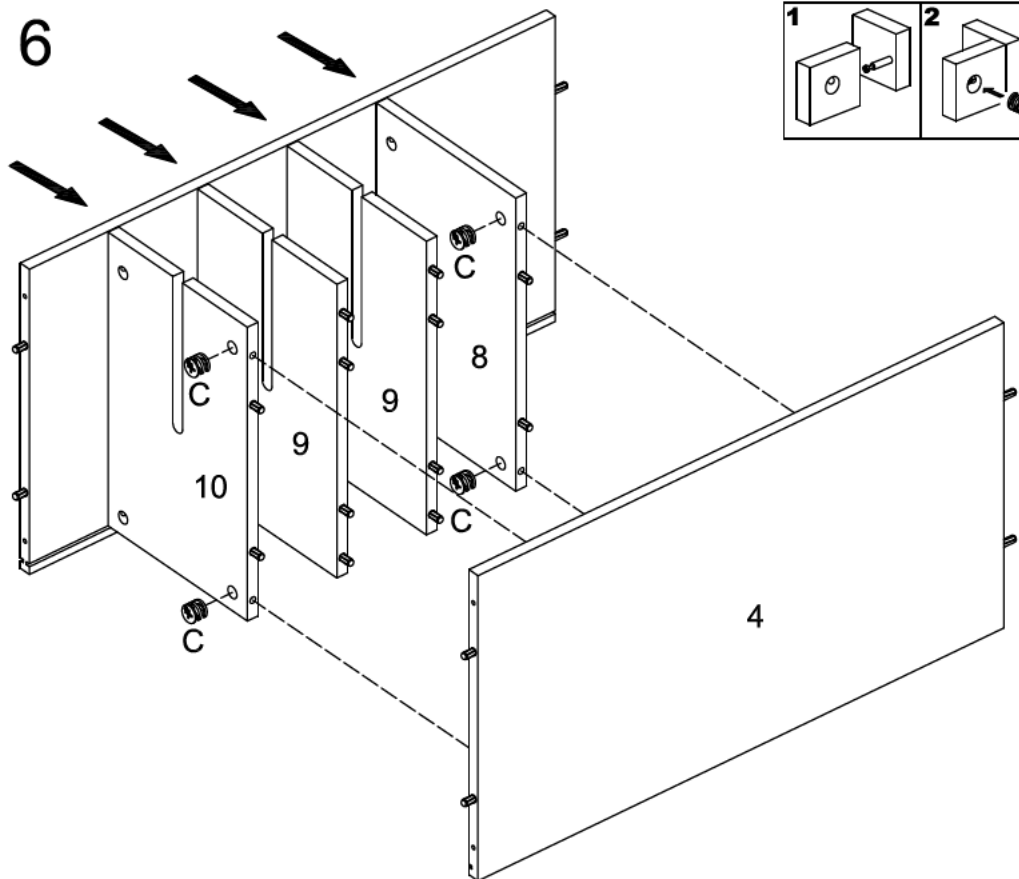

Step 7

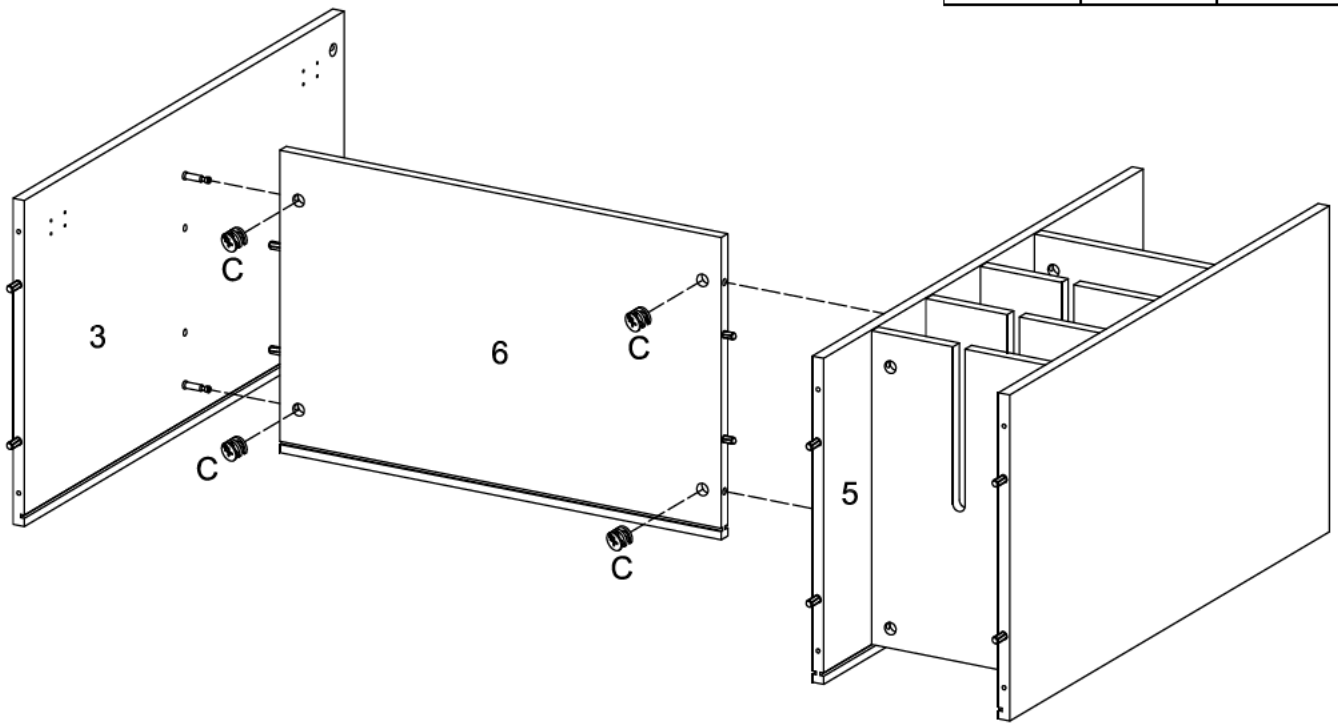
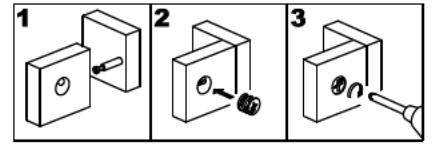

Step 8

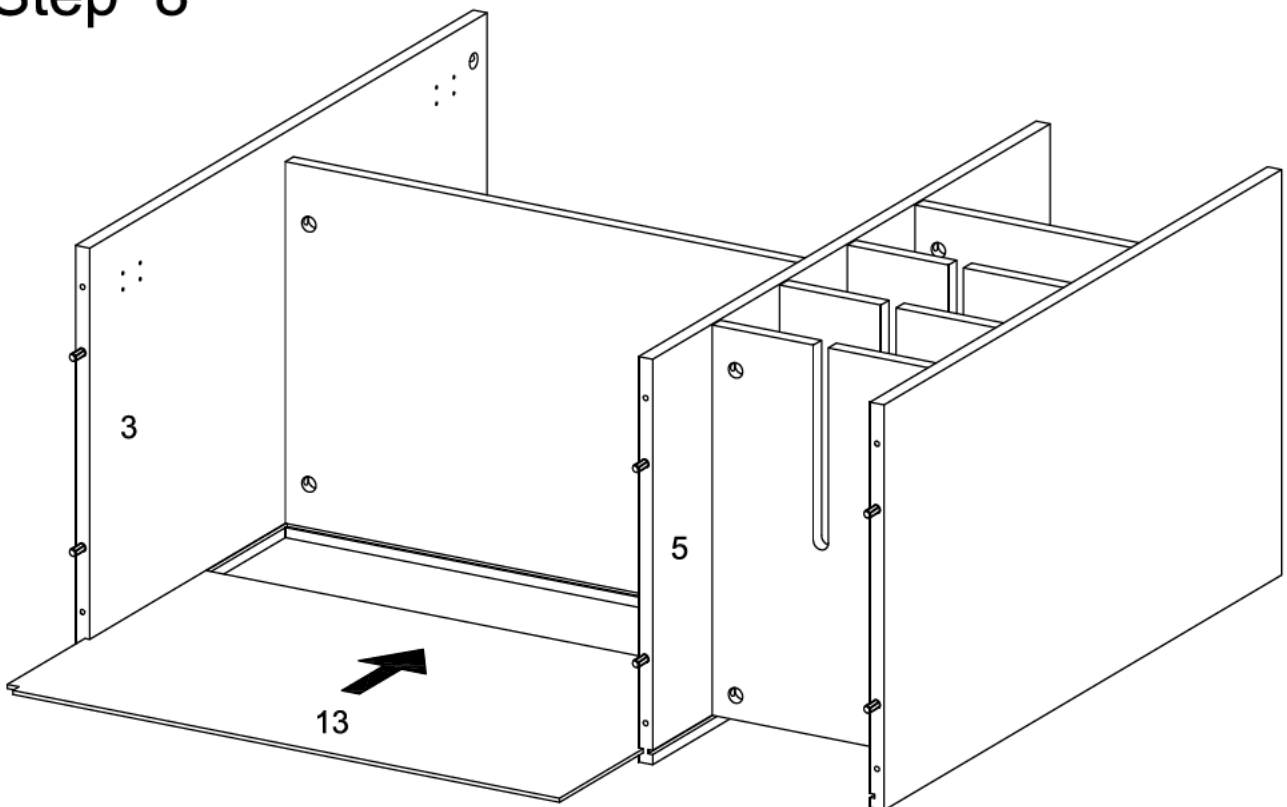

Step 9

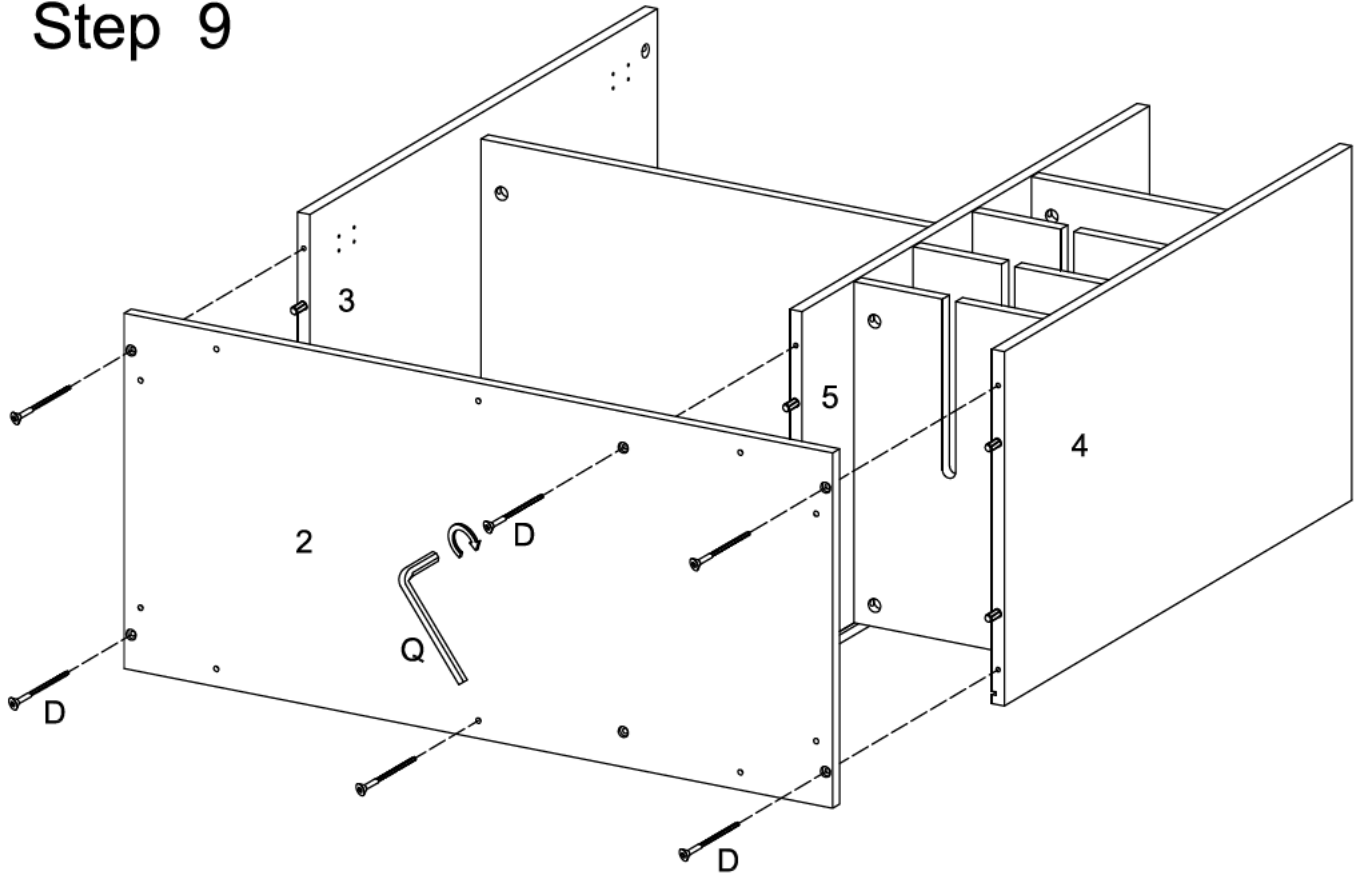

Step 10

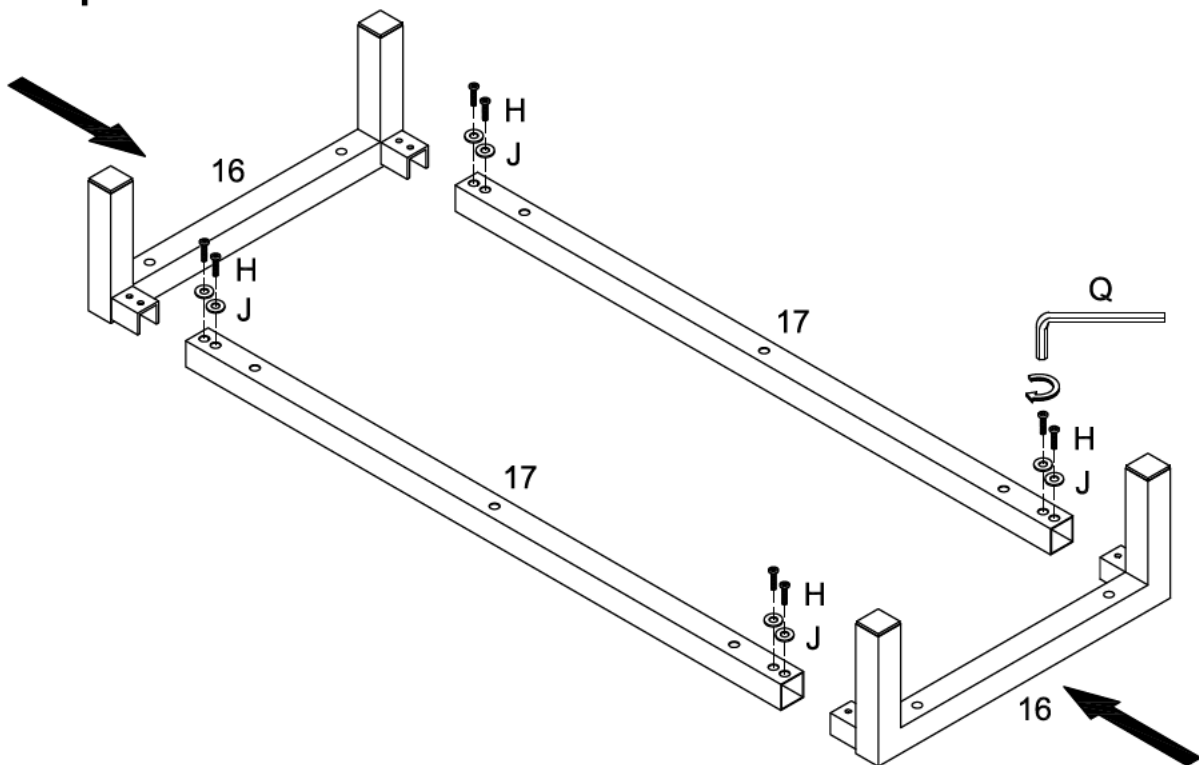

Step 11

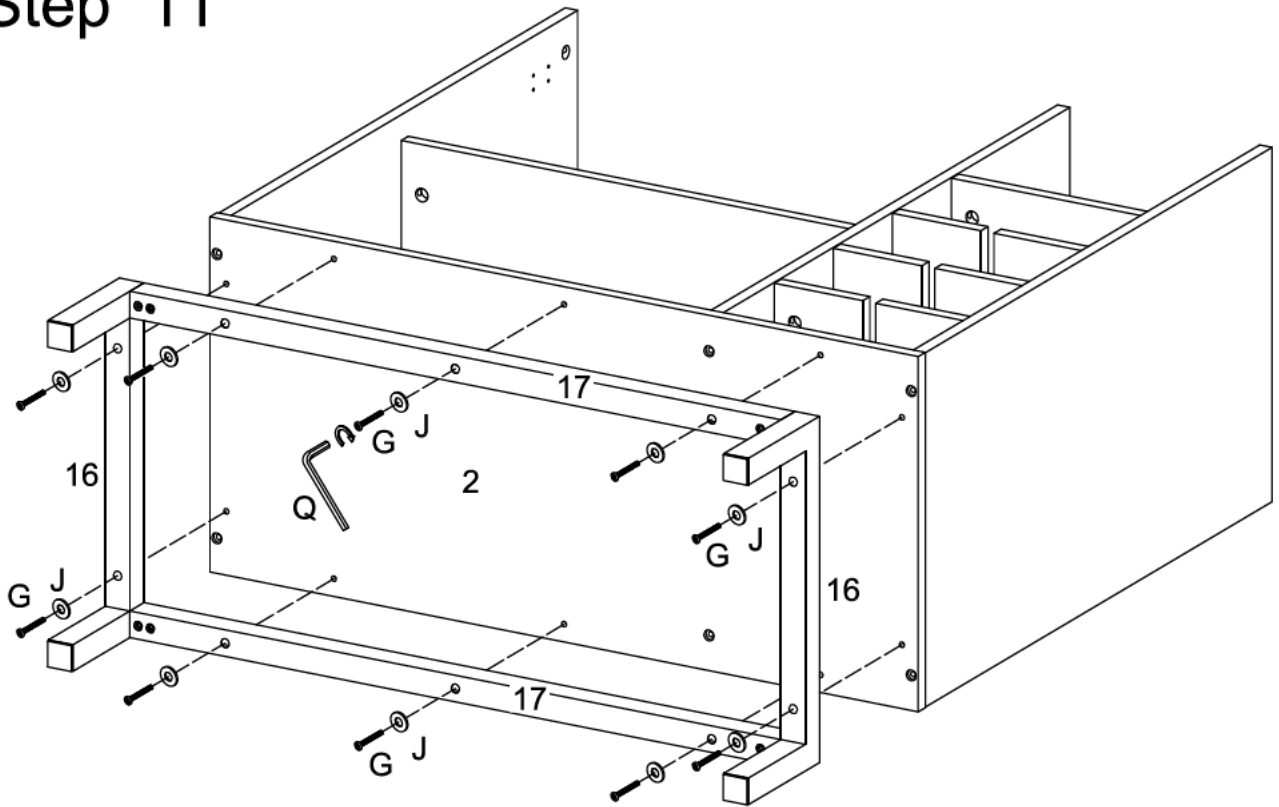

Step 12

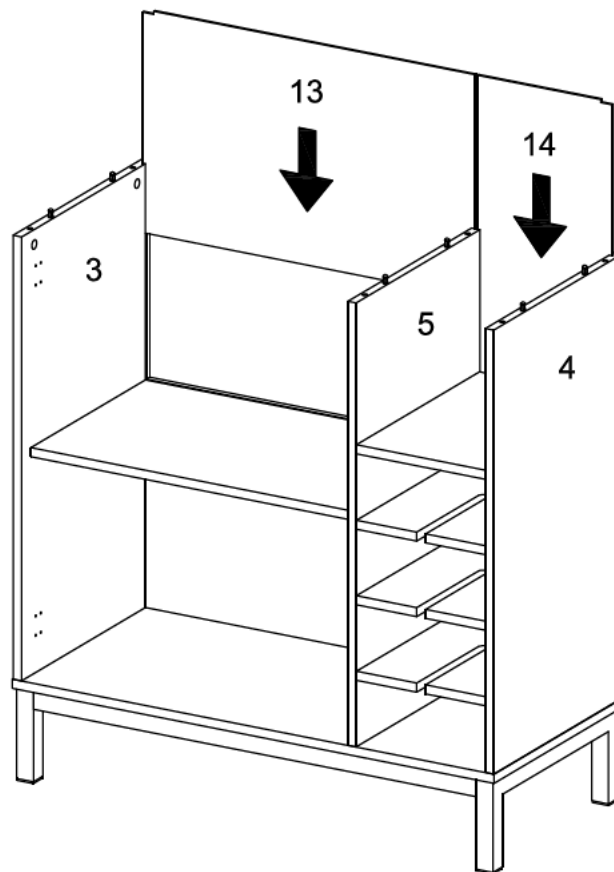

Step 13

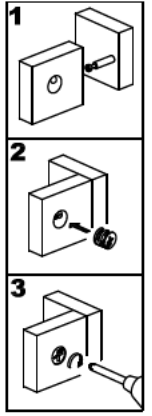
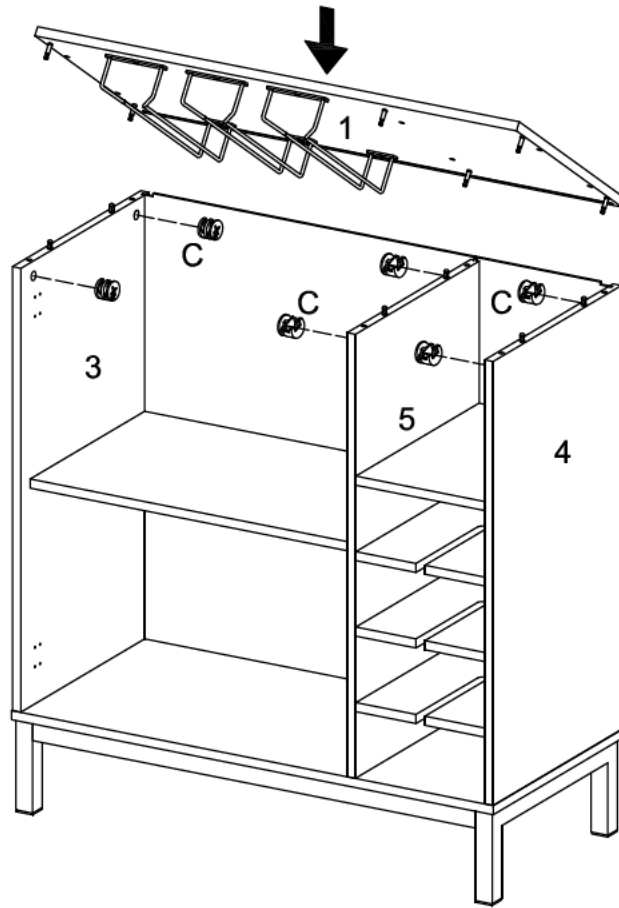

Step 14

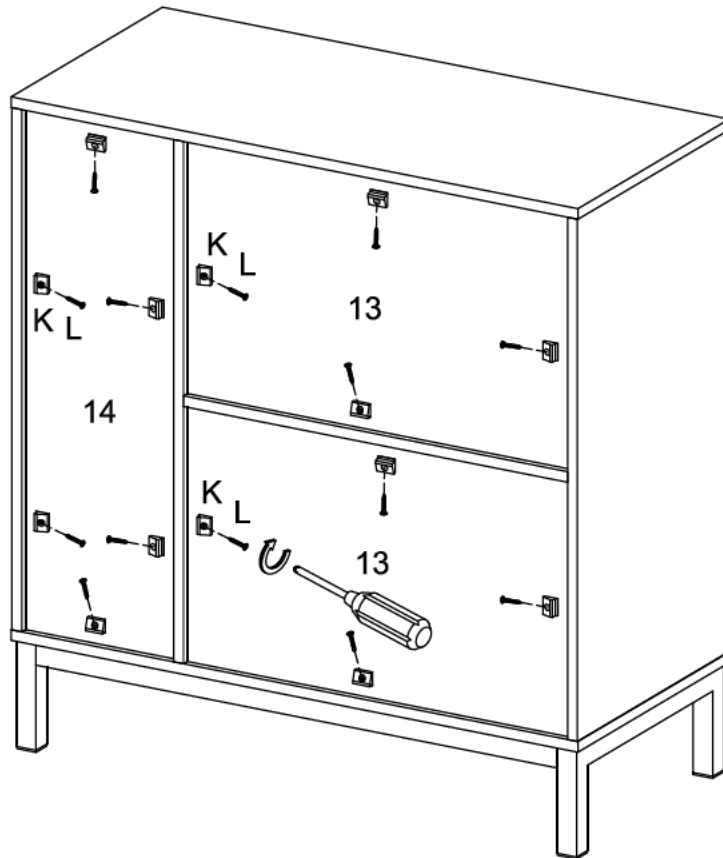

Step 15

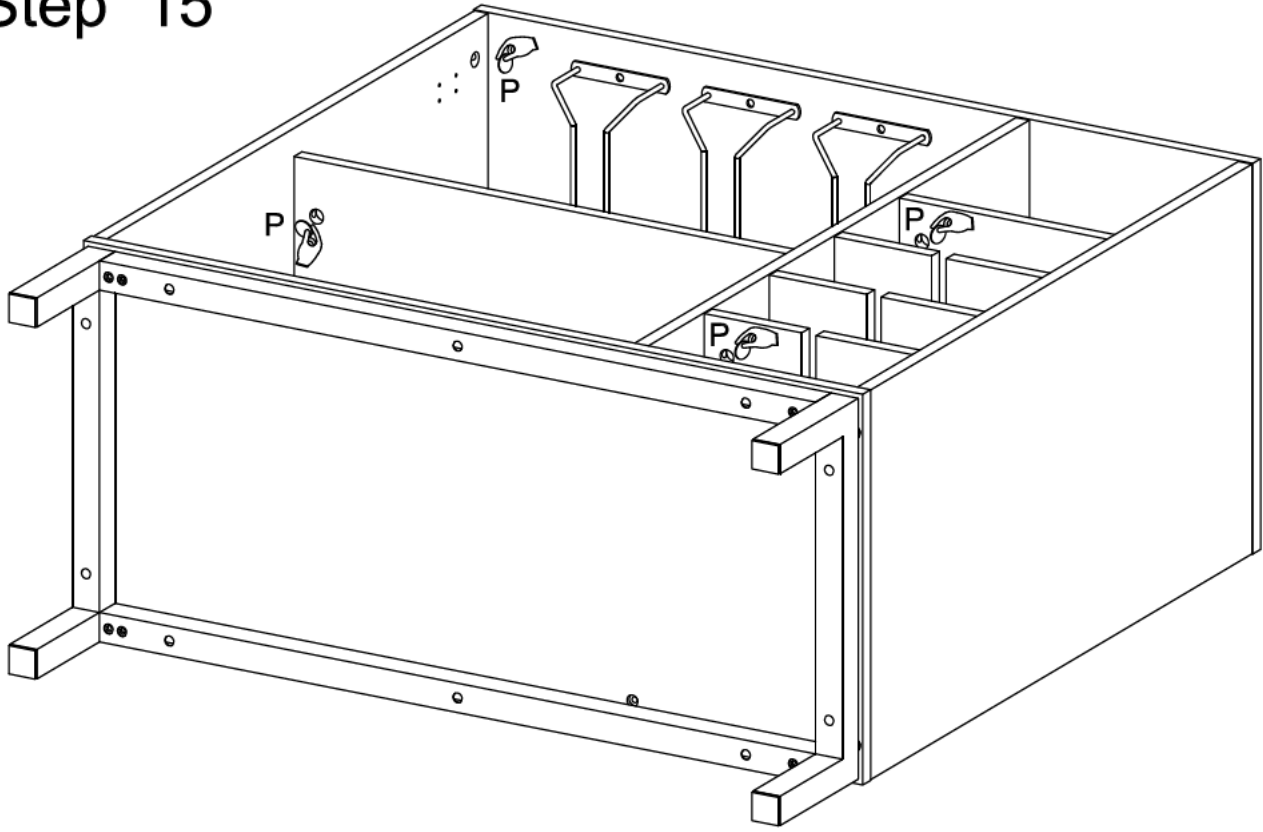

Step 16

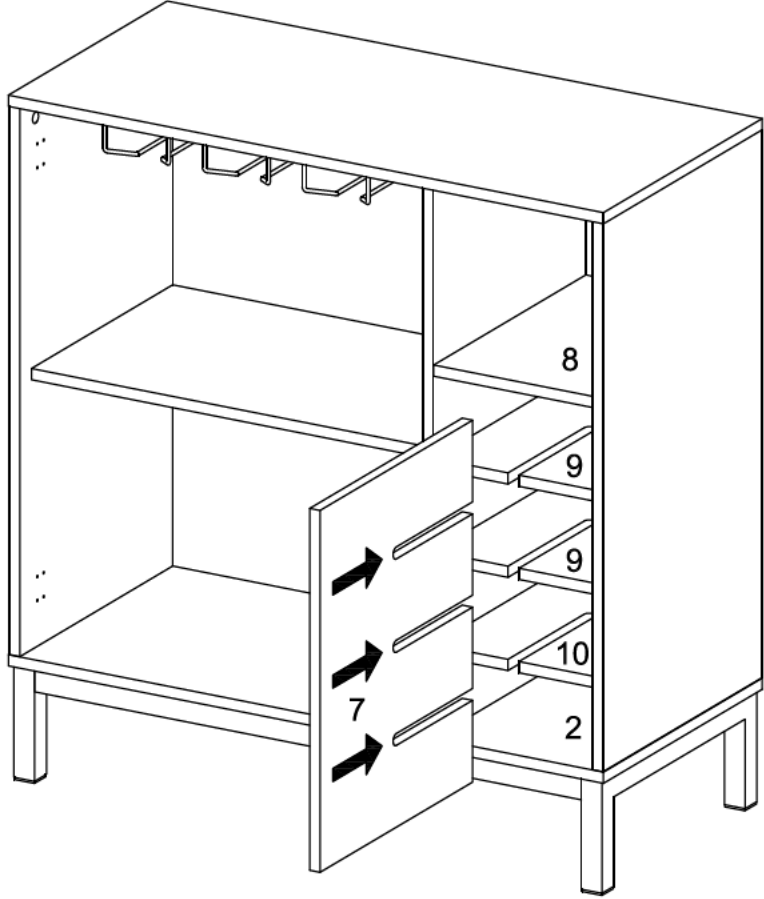

Step 17

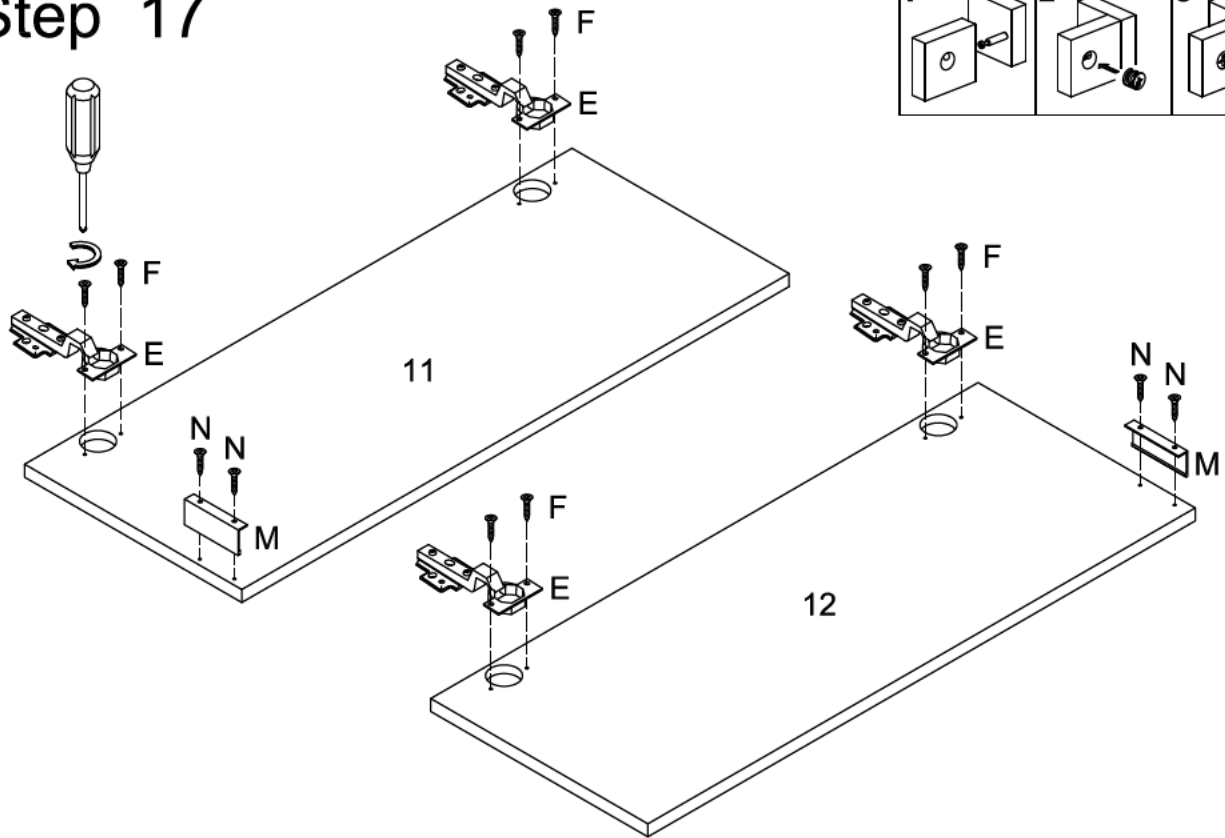

Step 18

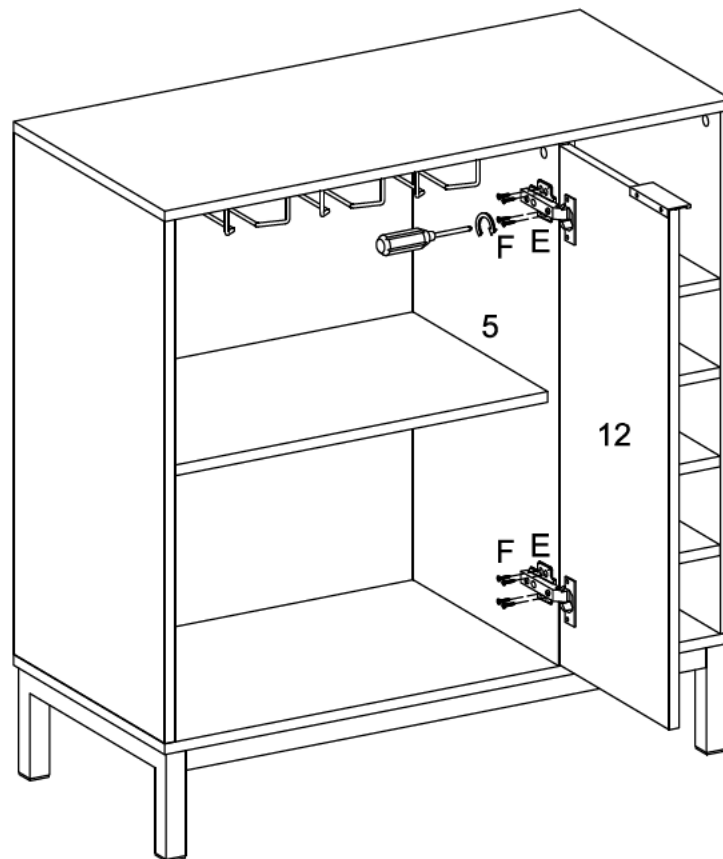

Step 19

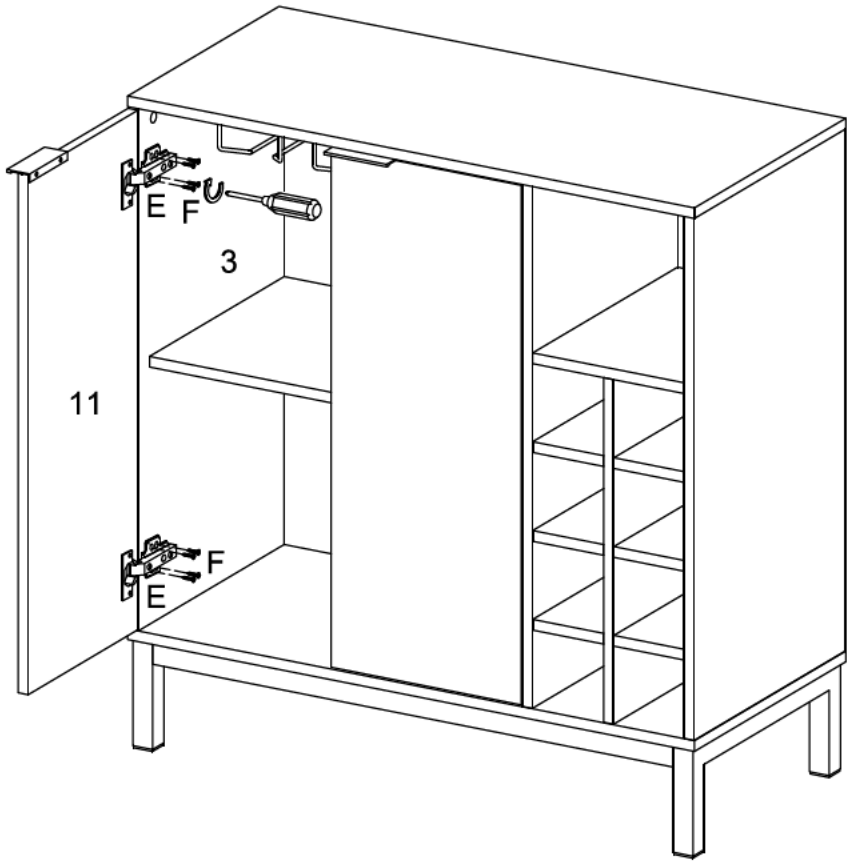

Step 20

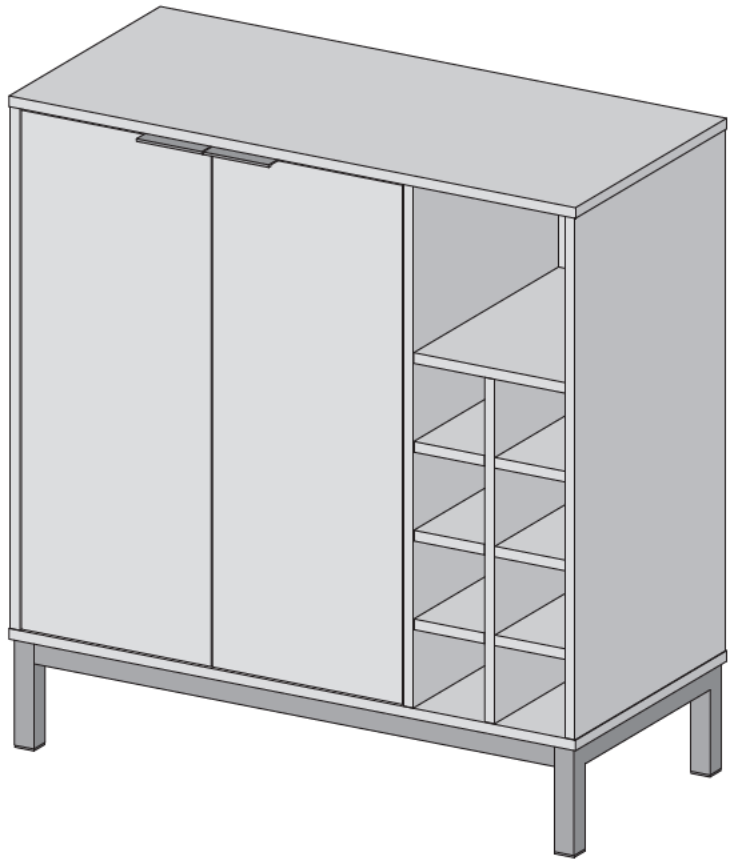

Final Assembly