

ASSEMBLY INSTRUCTIONS SS16304BK

10'X14' Attached Pergola

Thank you for choosing our product.

Please read the contents on the second page carefully.

- Before starting the installation, please thoroughly check the listed accessories below and read this manual attentively.
- Then proceed with the assembly step by step. If you have any questions, please don't hesitate to contact us.

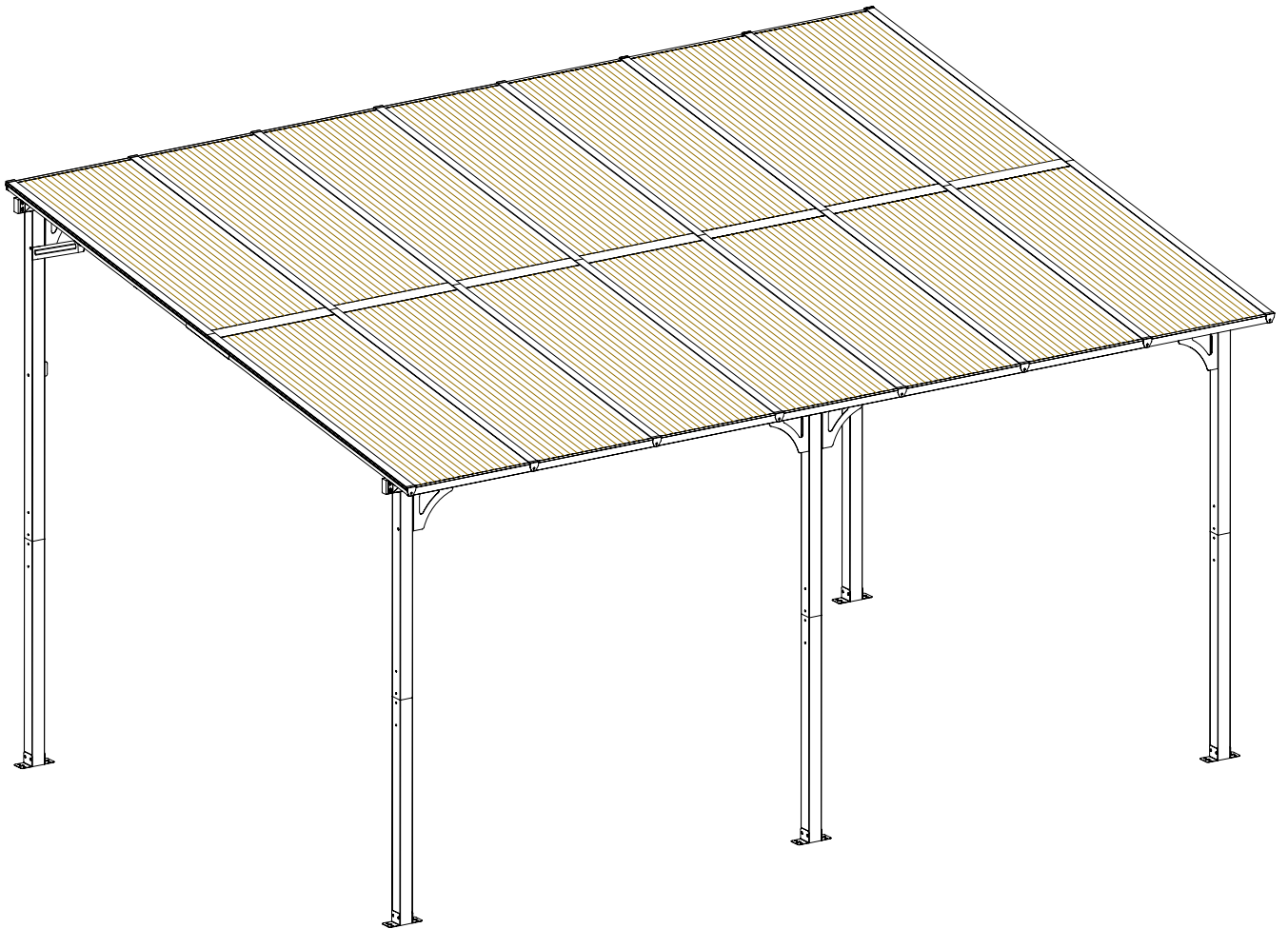

Attention

1. Thank you for trusting us.

You are entitled to a one-year warranty and lifelong customer service, and we have marked detailed notes on the second page.

2. Our gazebo is packaged in 2 boxes. Box A contains all the frames, while Box B contains all the top panels.

3. We encourage you to reach out to us at the earliest if you encounter any issues.

4. We kindly request your attention to installation safety and child safety.

To Every Customer Who Has Purchased Our Gazebos

Before you begin the installation, please take a few minutes to carefully read the following important notes and be aware of your rights and entitlements.

Some of Your Concerns:

1. Please note that if you find any damage to the package upon arrival, resulting in loss of internal components or visible damage, please contact us. We will take responsibility for any damages caused during transportation.
2. Please ensure that you begin installation after receiving both boxes of the package. If not, please contact us to inquire about the corresponding package status, and we will respond within 24 hours.
3. Product stability has been tested: the product can withstand winds of approximately 40-60 mph and a static pressure test of 6.5 lbs per square foot after correct installation and fixation. (Snow accumulation of about 7 inches in thickness will not pose a threat to the product.)
4. If you have any questions regarding accessory defects, product use, or product installation, please feel free to contact us. We have simple installation videos available for you.

Some Precautions:







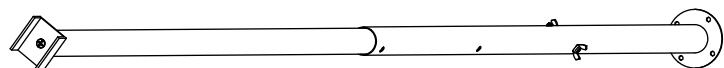



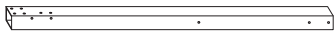
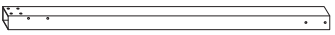
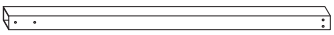
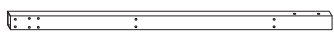
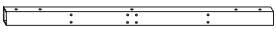
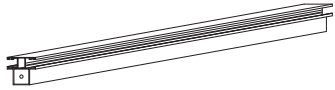

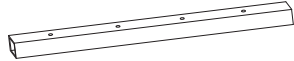
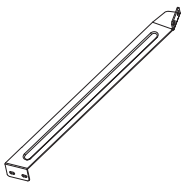
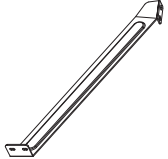
1. Please use the tools we provide to secure the gazebo to the wall to ensure stability.
*Please purchase matching ground stakes for securing the product to the ground according to the installation area you plan. If you are unsure about how to choose, please let us know.
2. Please tighten the screws after ensuring that all screw holes have been properly inserted to avoid uneven hole alignment.
3. Please use a ladder when installing the top part.
4. Keep children away during the installation process, as the product contains small parts that could be swallowed.
5. Do not choose to install the product in strong winds or severe weather conditions.

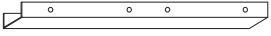
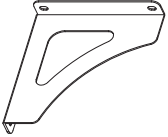
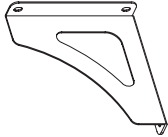
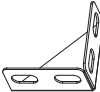
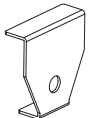
Your Rights And Benefits:

1. You are entitled to a one-year warranty on the product and lifelong 24/7 customer service.
2. If you wish to connect multiple products together through DIY, please contact us for advice on the connections or to seek the necessary accessories for your construction needs.
3. We're thrilled to introduce our brand-new adjustable and expandable support columns, designed to meet your utmost stability requirements. Feel free to get in touch with us if you're interested.

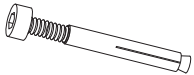

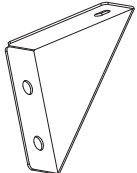

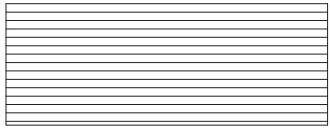

Parts List A

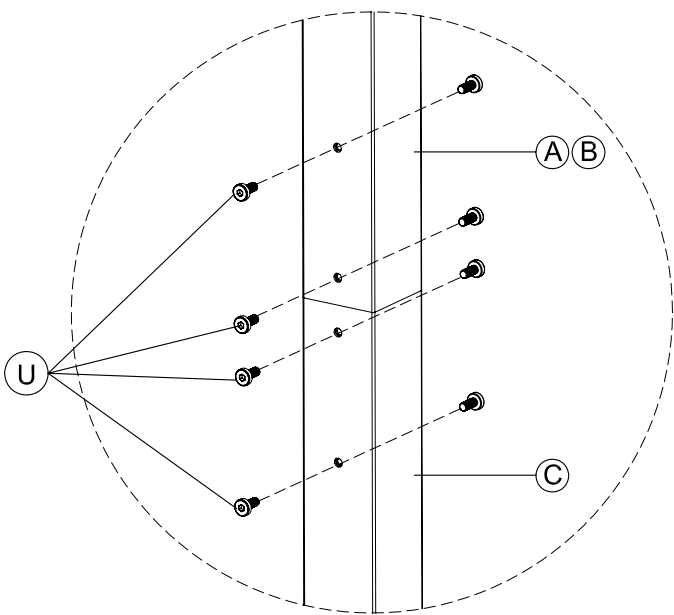
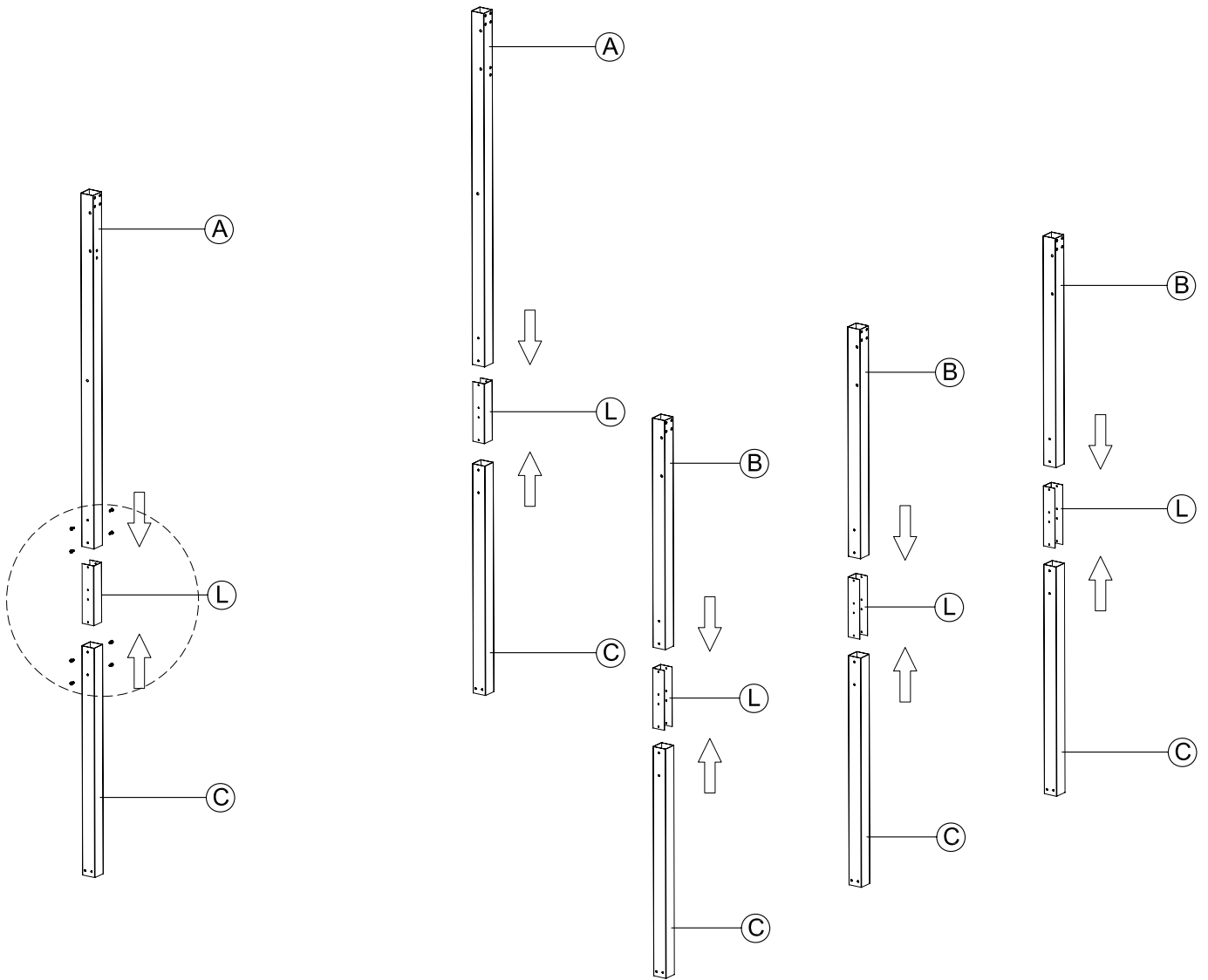

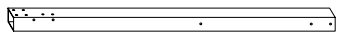
<p>A 2x</p>  <p>Top Back Leg</p>	<p>B 3x</p>  <p>Top Front Leg</p>	<p>C 5x</p>  <p>Bottom Leg</p>	<p>D 4x</p>  <p>Side Beam</p>
<p>D1 2x</p>  <p>Middle Beam</p>	<p>E 16x</p>  <p>Board Arm</p>	<p>F 14x</p>  <p>Board Protection</p>	<p>H 8x</p>  <p>Arm Hold Tube (side)</p>
<p>I 1x</p>  <p>Right Arm Hold</p>	<p>J 1x</p>  <p>Left Arm Hold</p>	<p>L 5x</p>  <p>Leg Connection</p>	<p>M 12x</p>  <p>Wall & Floor Connection</p>
<p>N 4x</p>  <p>Beam Connection</p>	<p>O 3x</p>  <p>Right Beam Hold</p>	<p>P 3x</p>  <p>Left Beam Hold</p>	<p>Q 16x</p>  <p>Arm & Beam Connection</p>
<p>R 16x</p>  <p>Arm Protection</p>	<p>T 8x</p>  <p>Arm Down Connection</p>	<p>U 255x</p>  <p>Bolt M6*15mm</p>	<p>V 20x</p>  <p>Bolt M6*15mm</p>
<p>W 6x</p>  <p>Expansion Bolts</p>	<p>X 1x</p>  <p>Allen Wrench (S4)</p>	<p>Y 1x</p>  <p>Allen Wrench (S6)</p>	<p>Z 1x</p>  <p>Middle Wall Connection</p>
<p>Parts List B</p>	<p>S 14x</p>  <p>Arm Connection</p>	<p>G 7x</p>  <p>Middle Board Connection</p>	<p>K 14x</p>  <p>UV Protected Board</p>

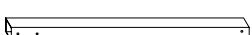
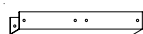
1





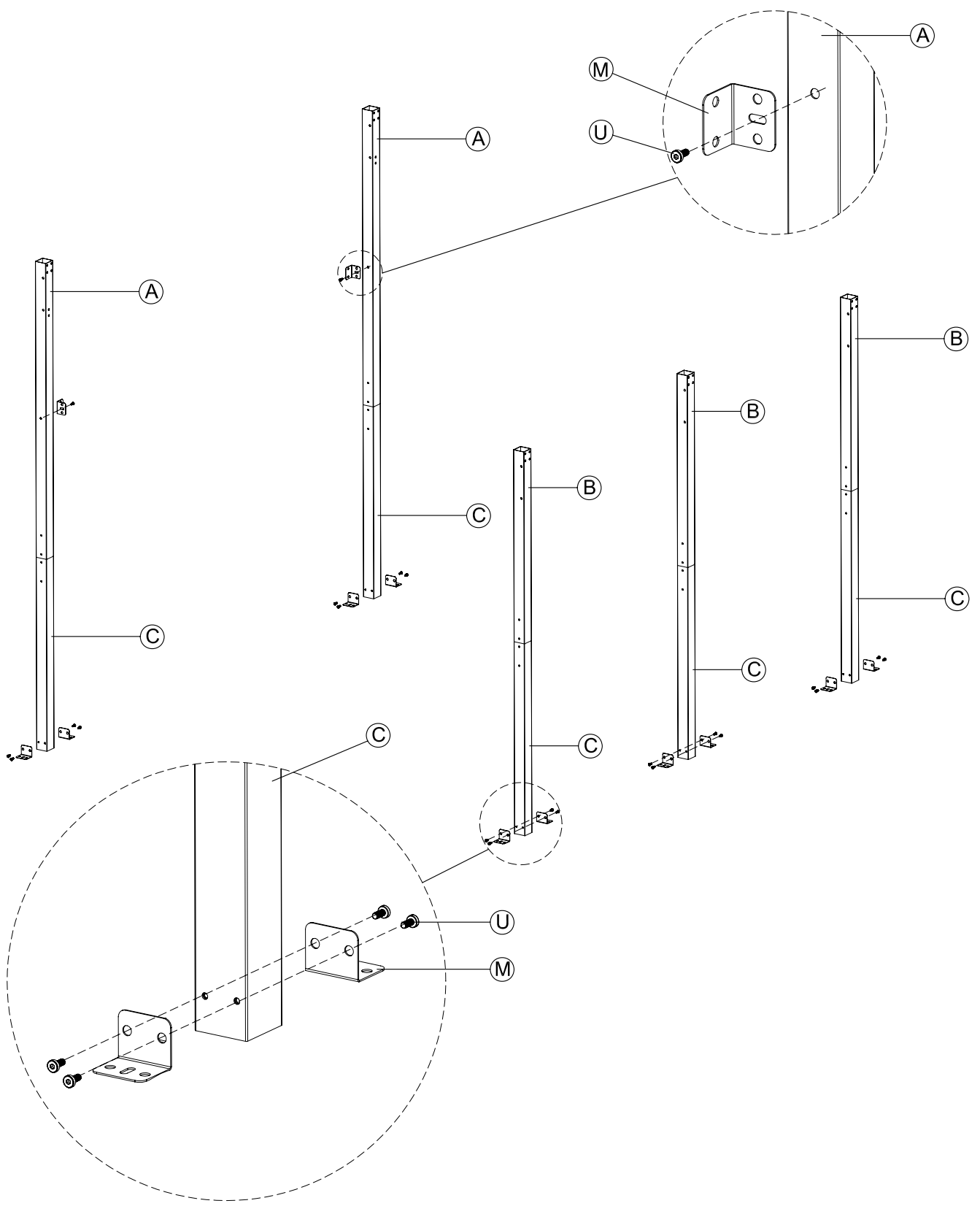

A		x2
B		x3
C		x5
L		x5
U		x40

2

M		x12
U		x22

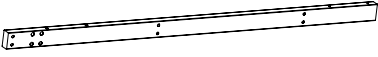

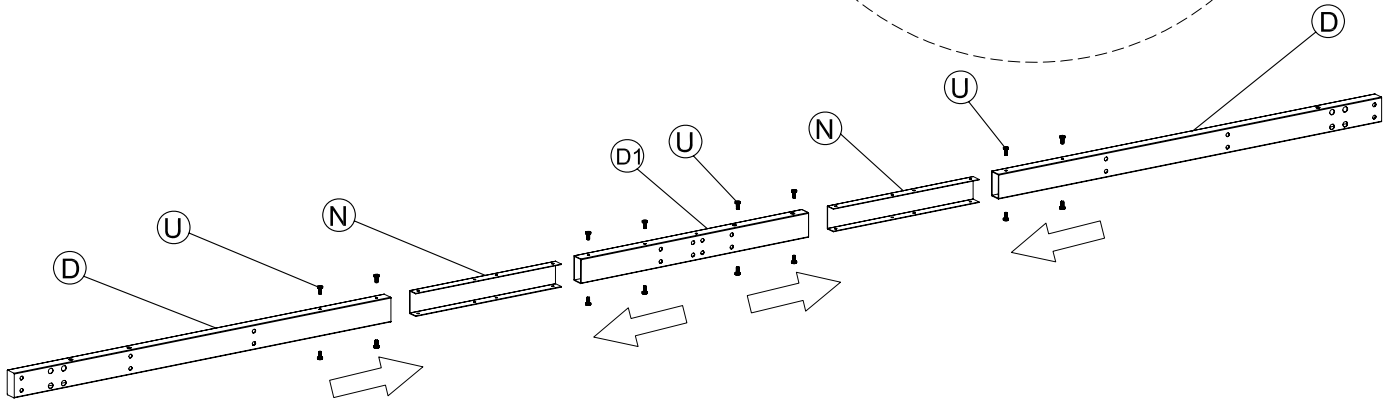
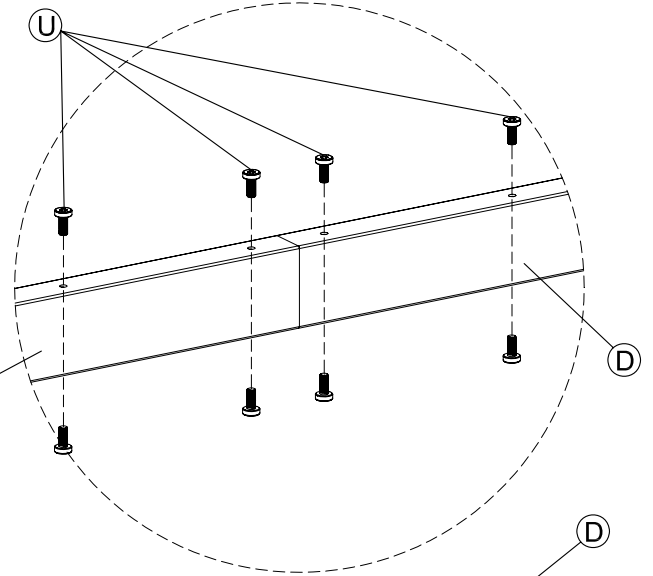

3

D		x4
D1		x2
N		x4
U		x32



4



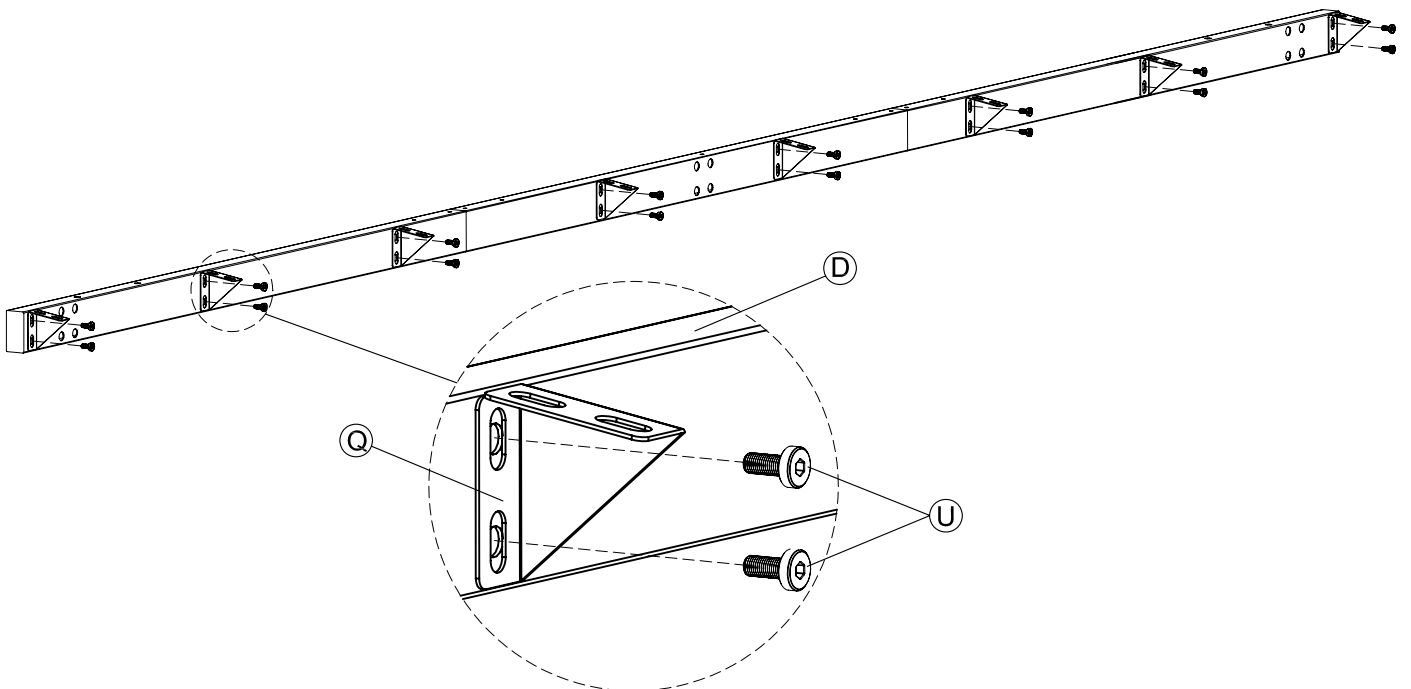

Q		x16
U		x32

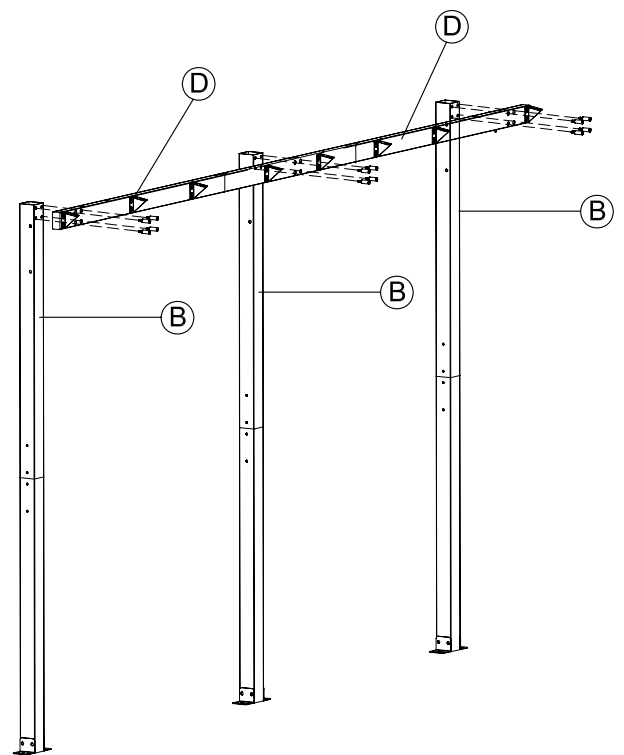
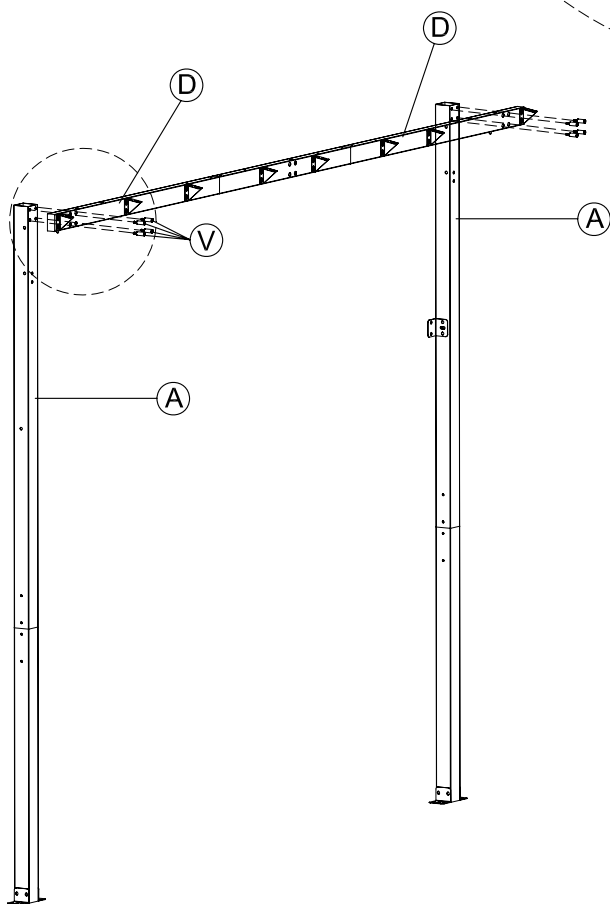
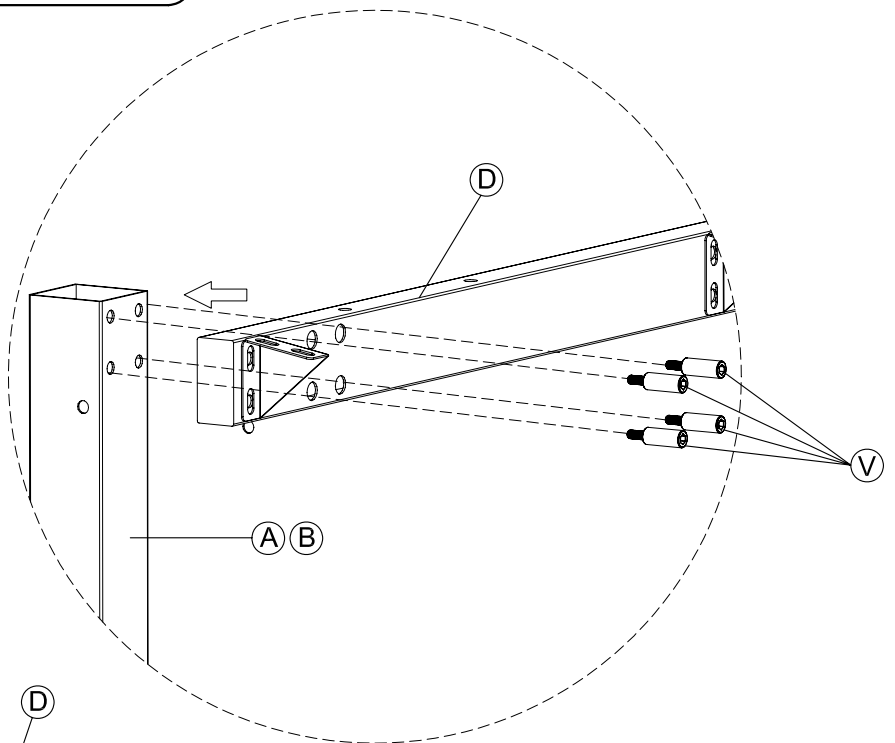
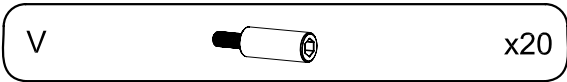

5



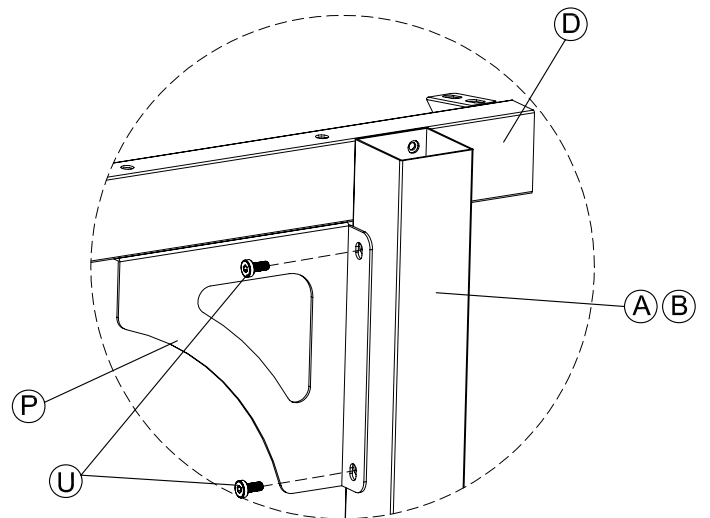
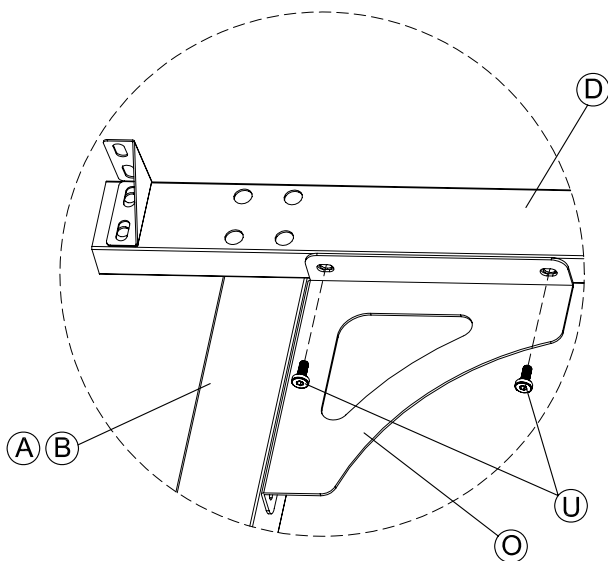
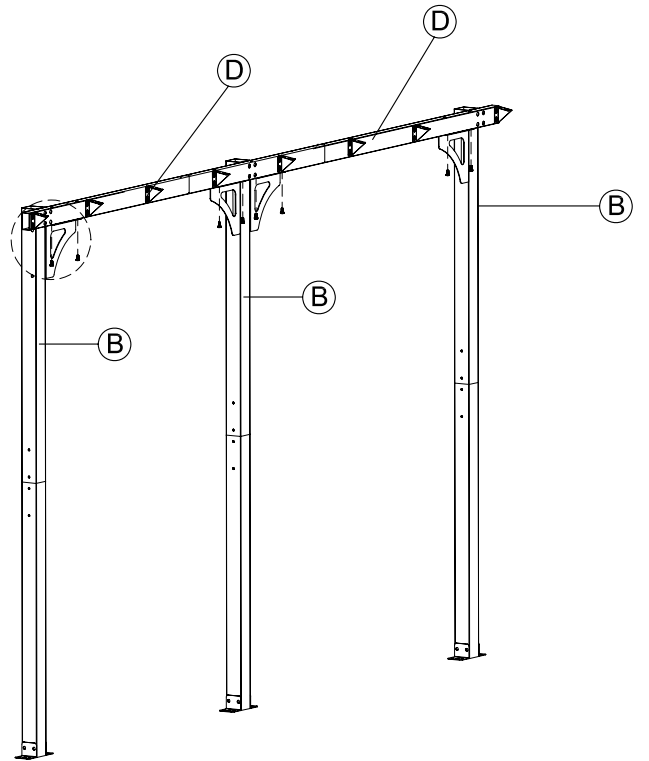
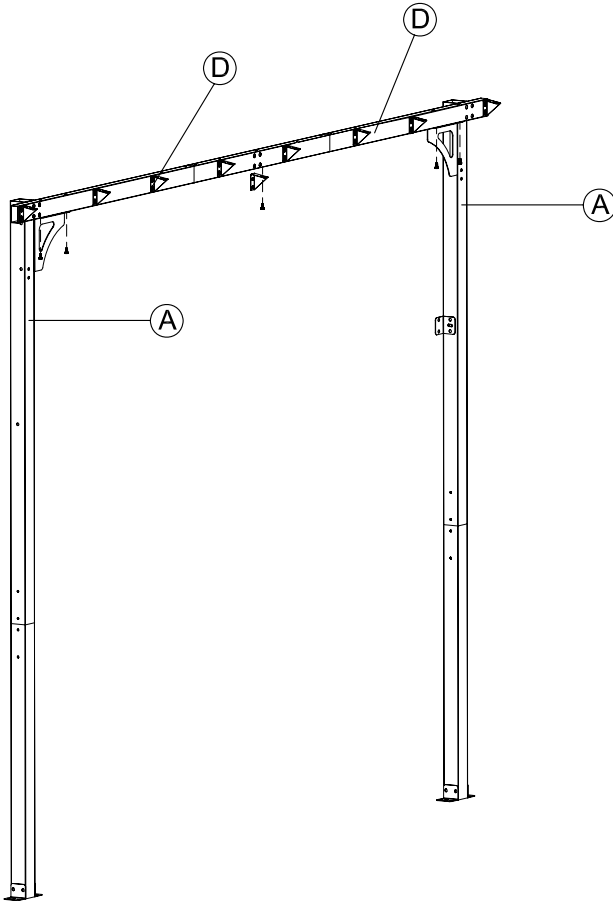
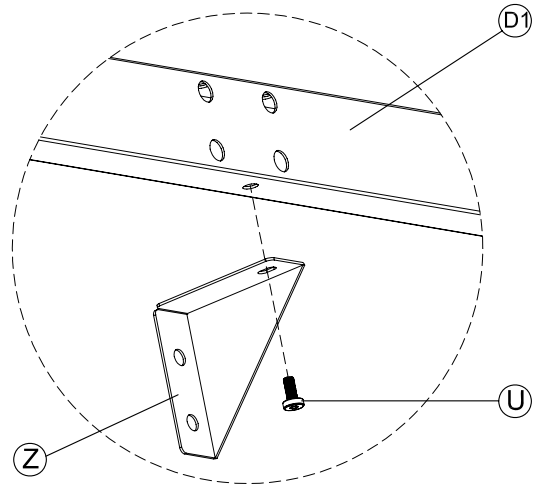

6

O		x3
P		x3
U		x25
Z		x1



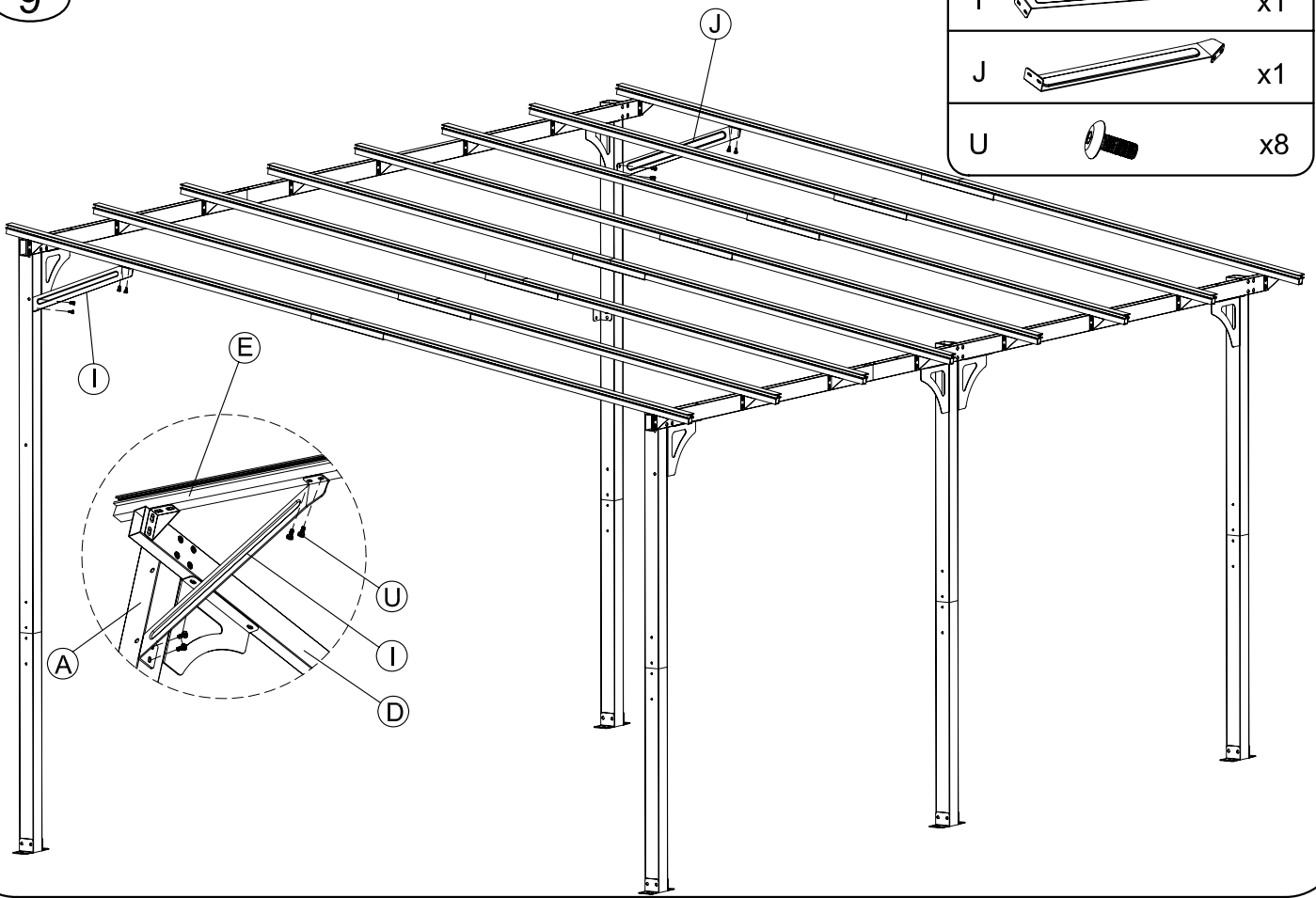

9

I		x1
J		x1
U		x8



10

S		x14
U		x16

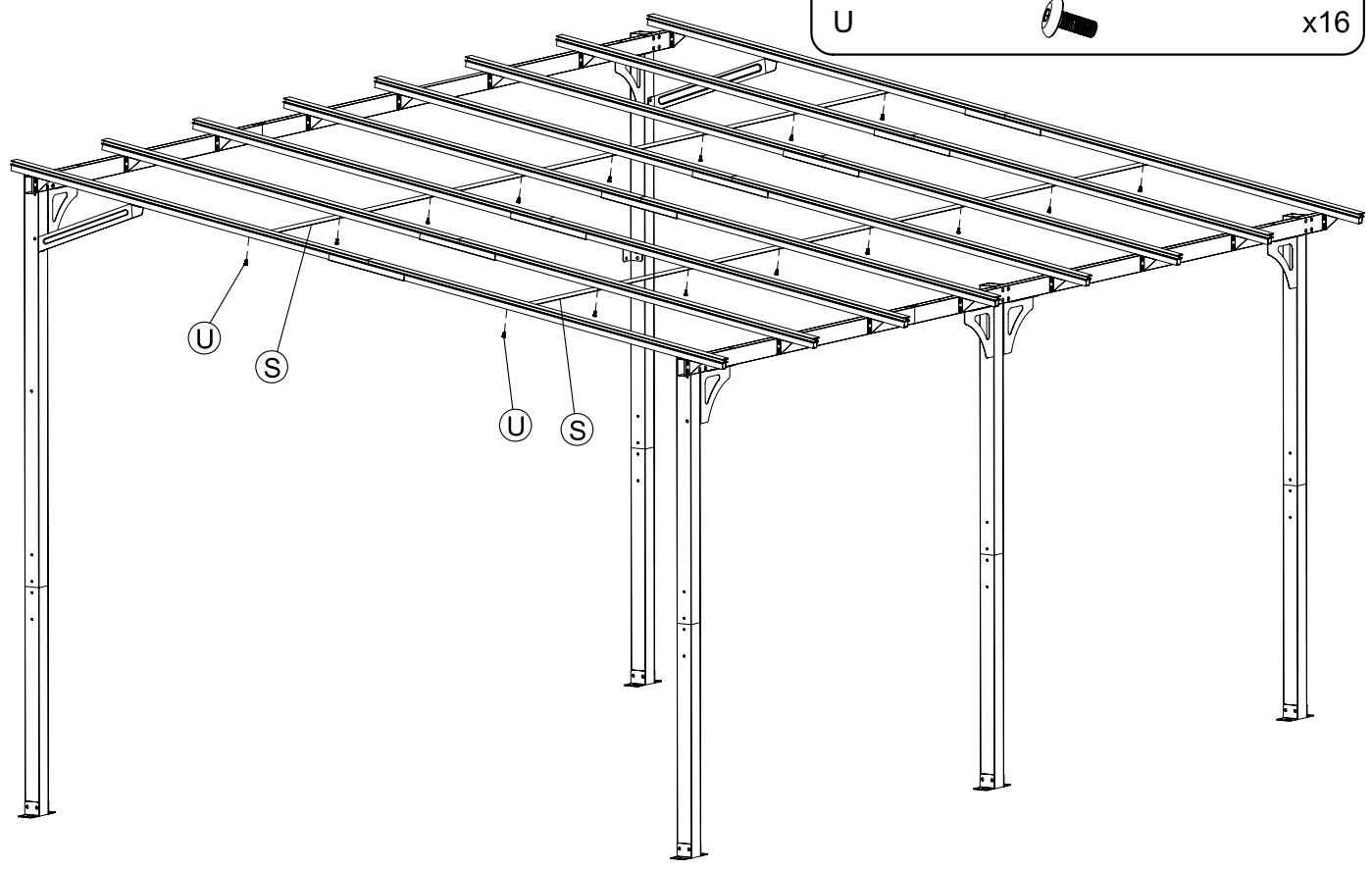

11

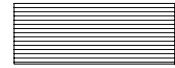

K

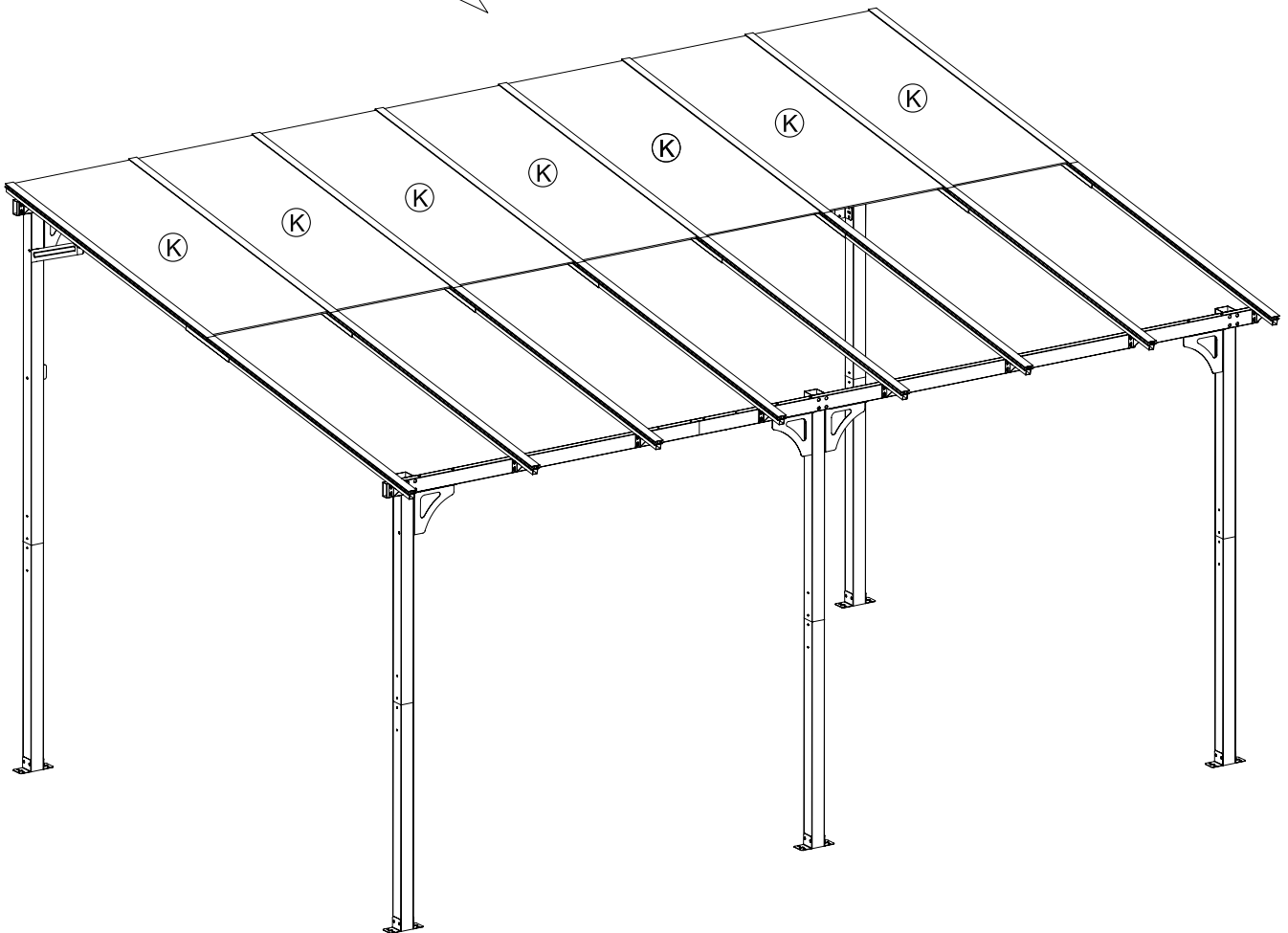
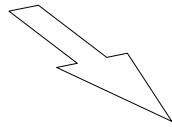
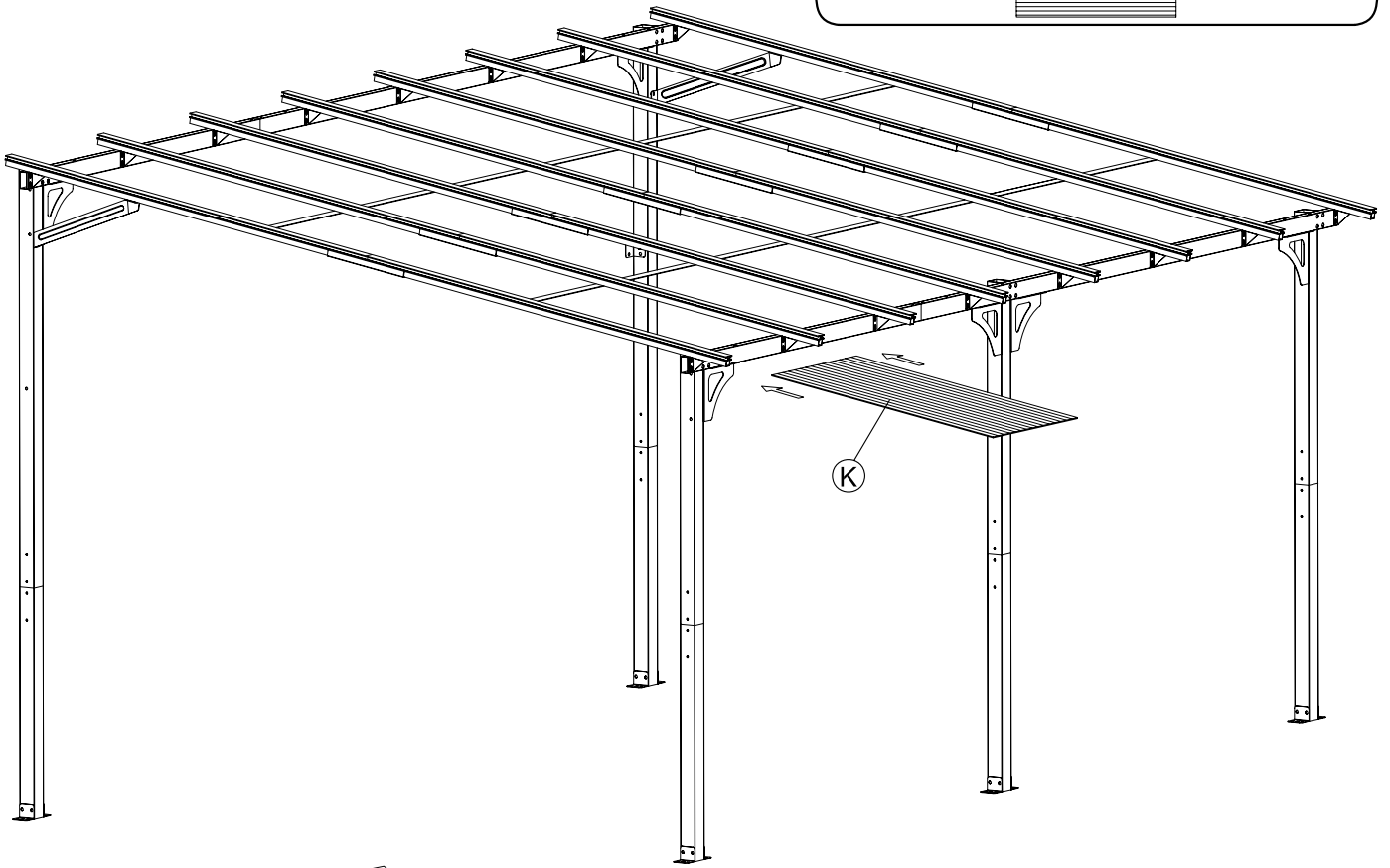

x7



12

F		x7
R		x8
U		x8

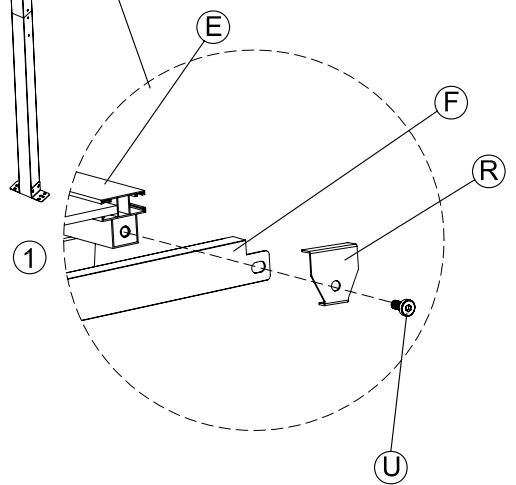
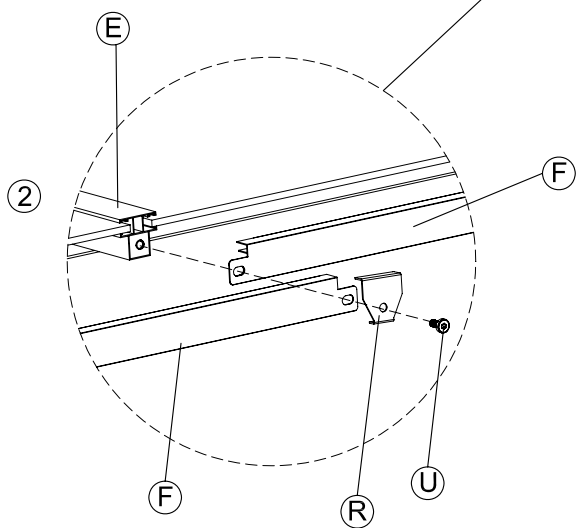
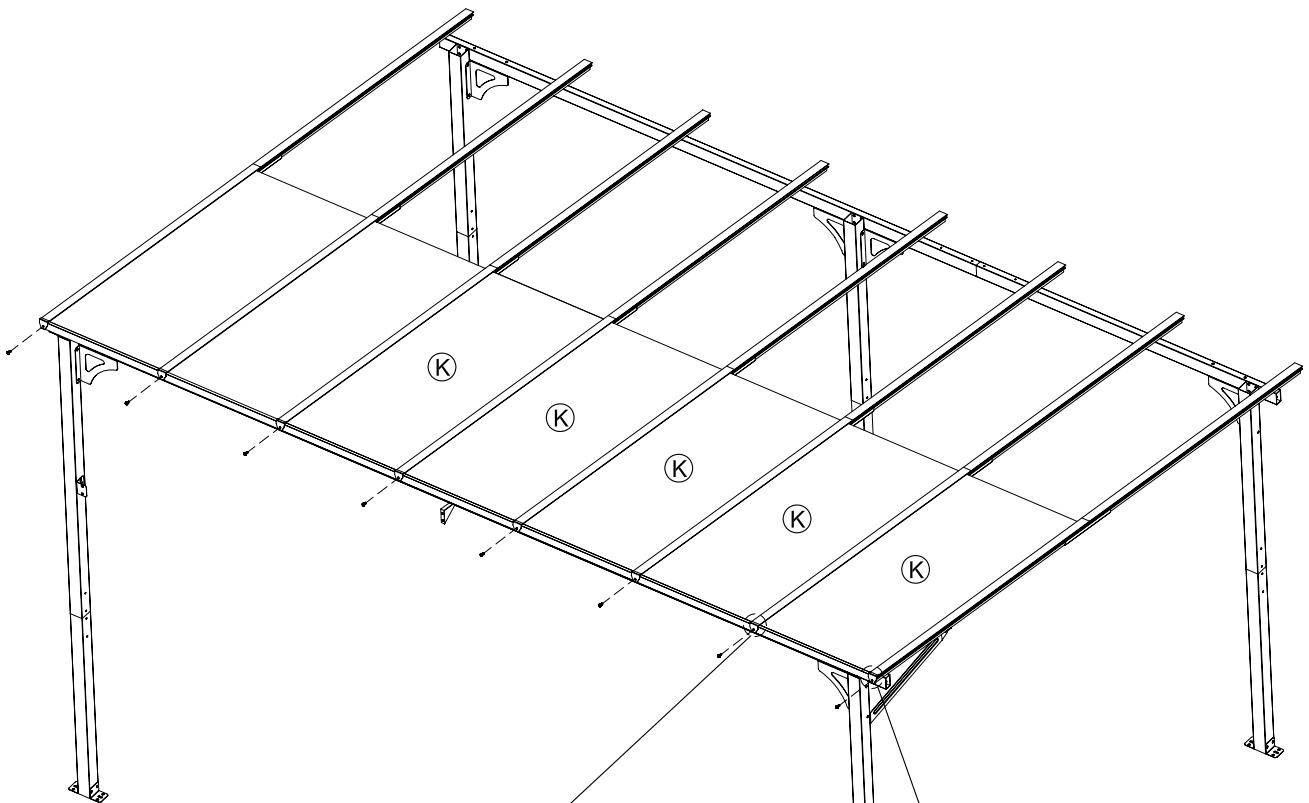

13

G  x7

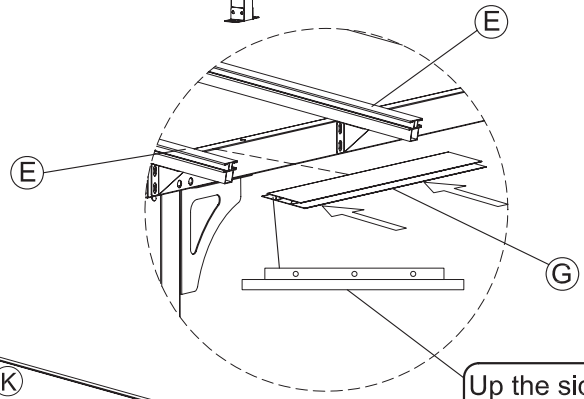
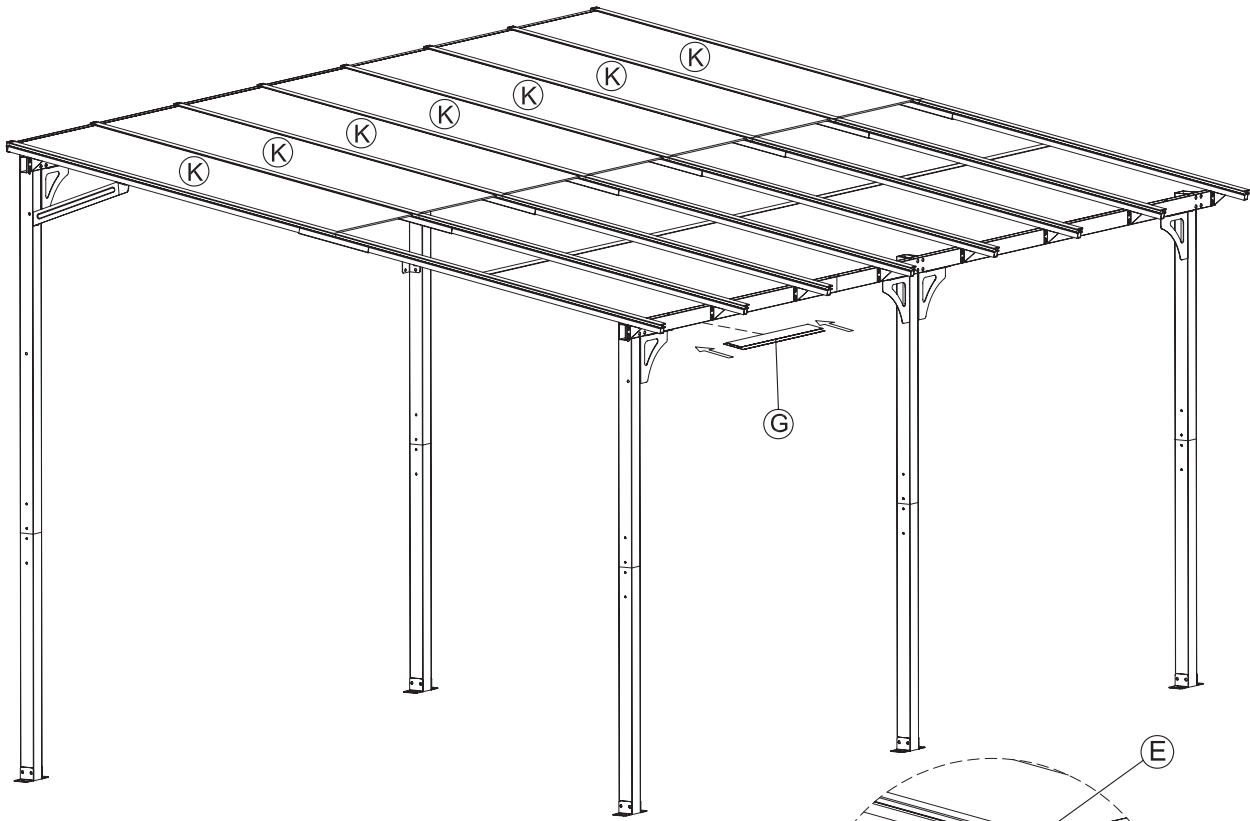

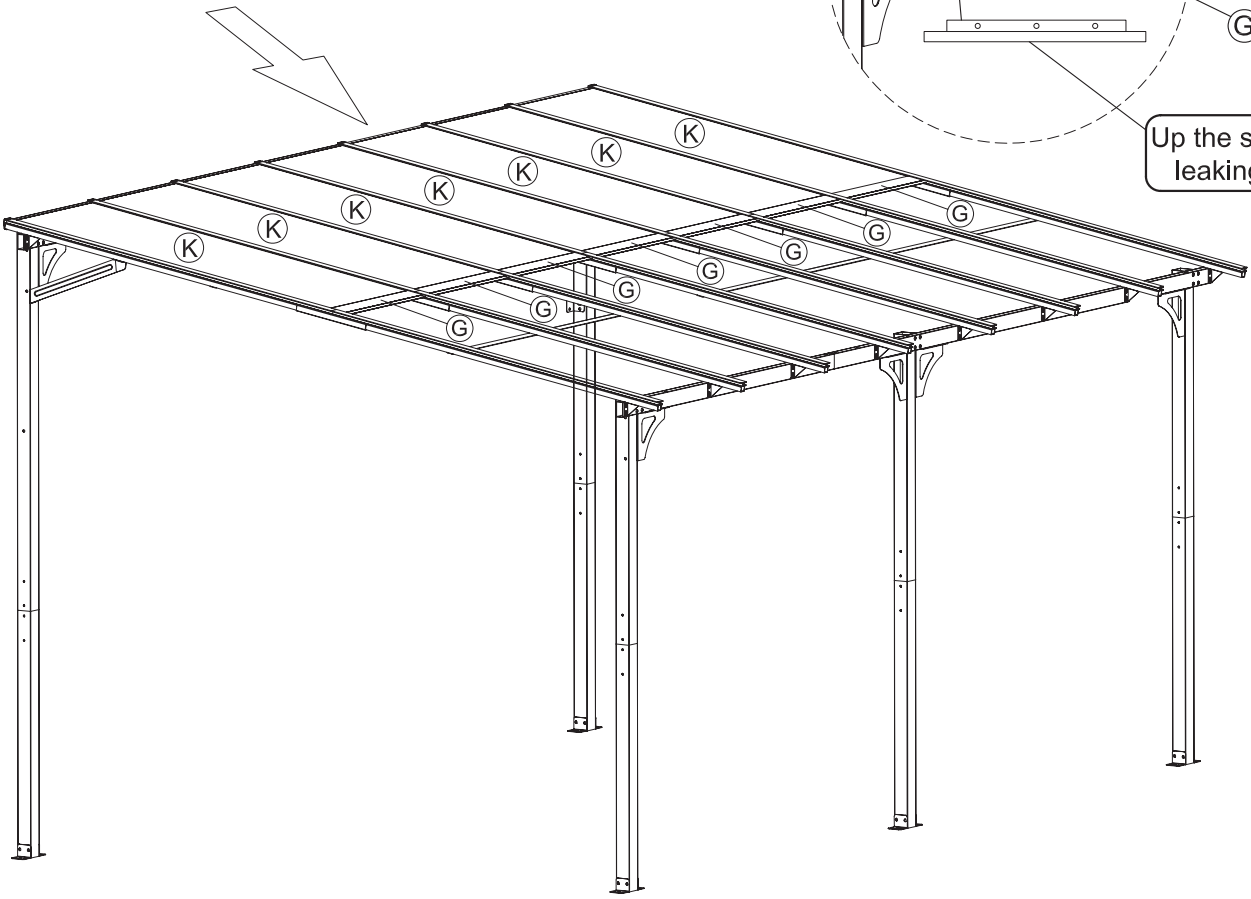

Up the side with leaking hole

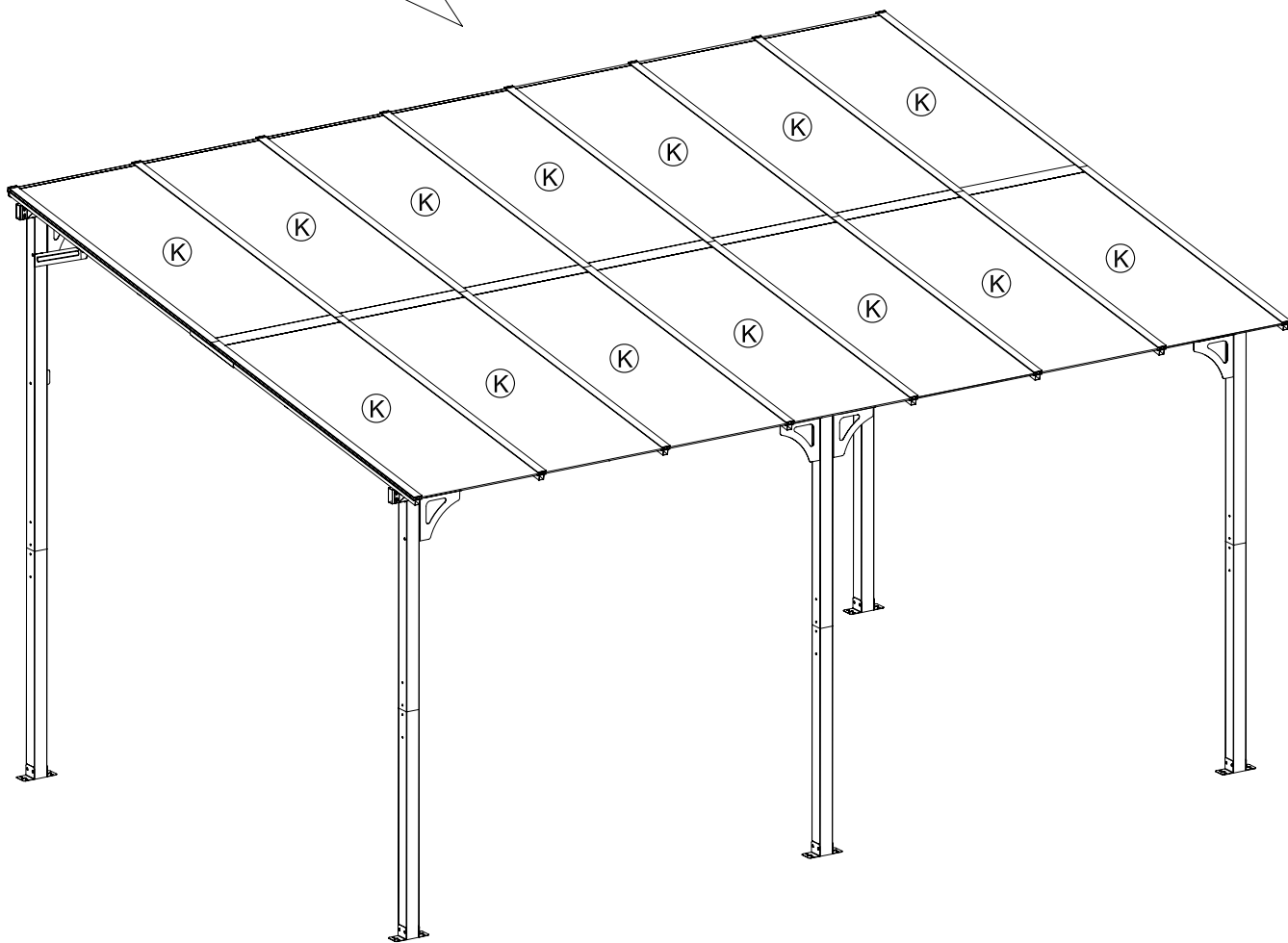
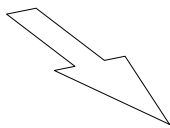
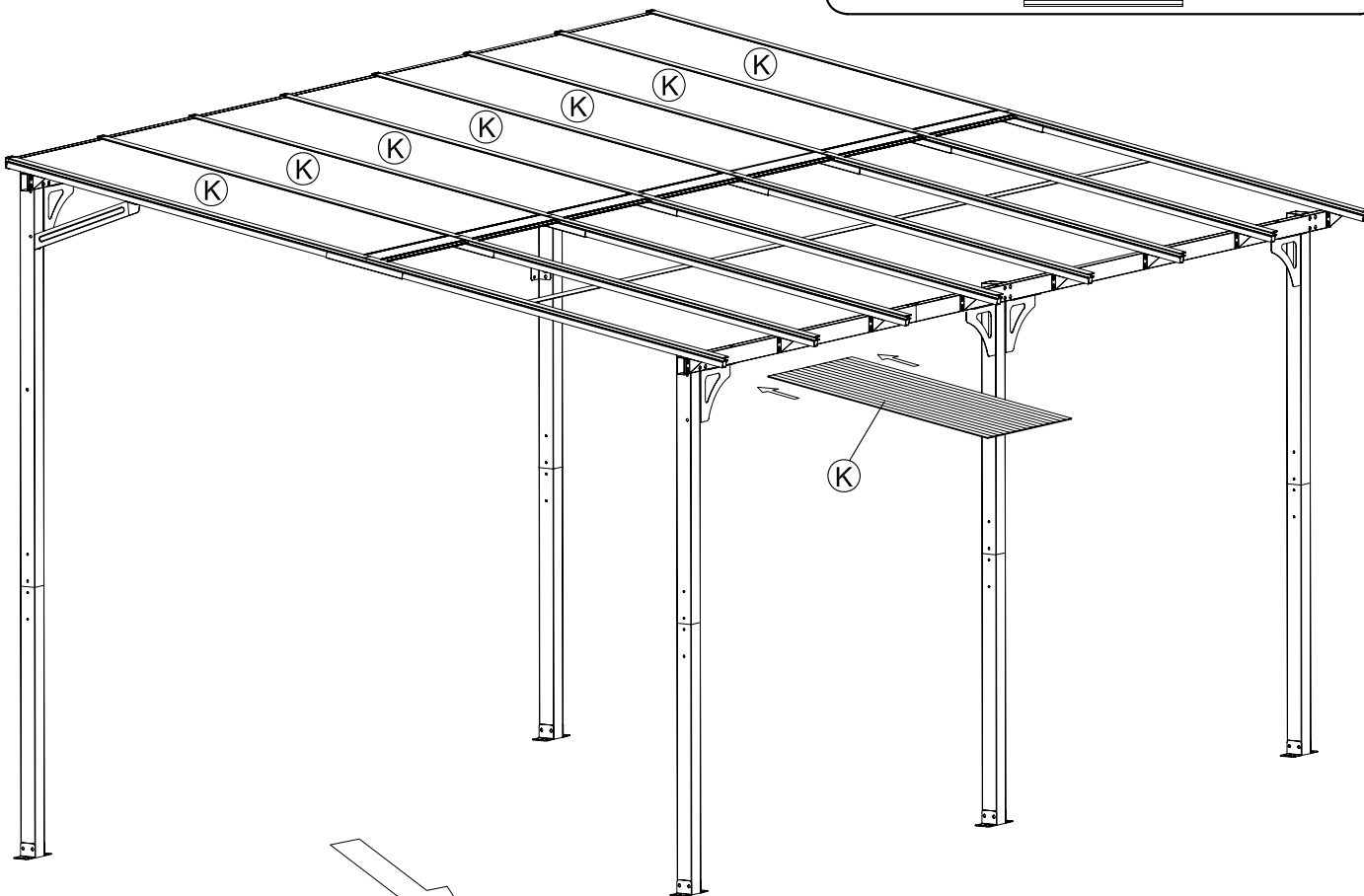



15

F		x7
R		x8
U		x8

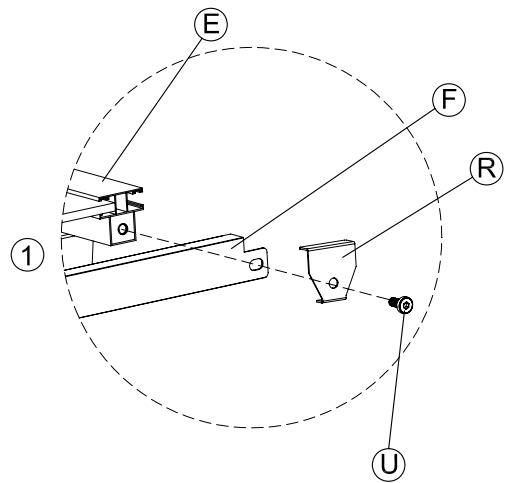
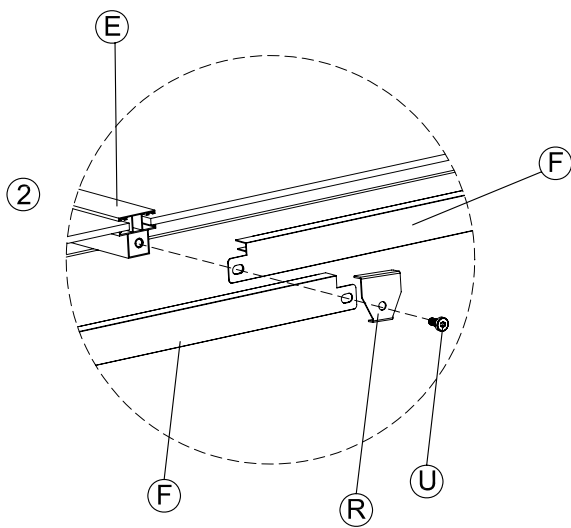
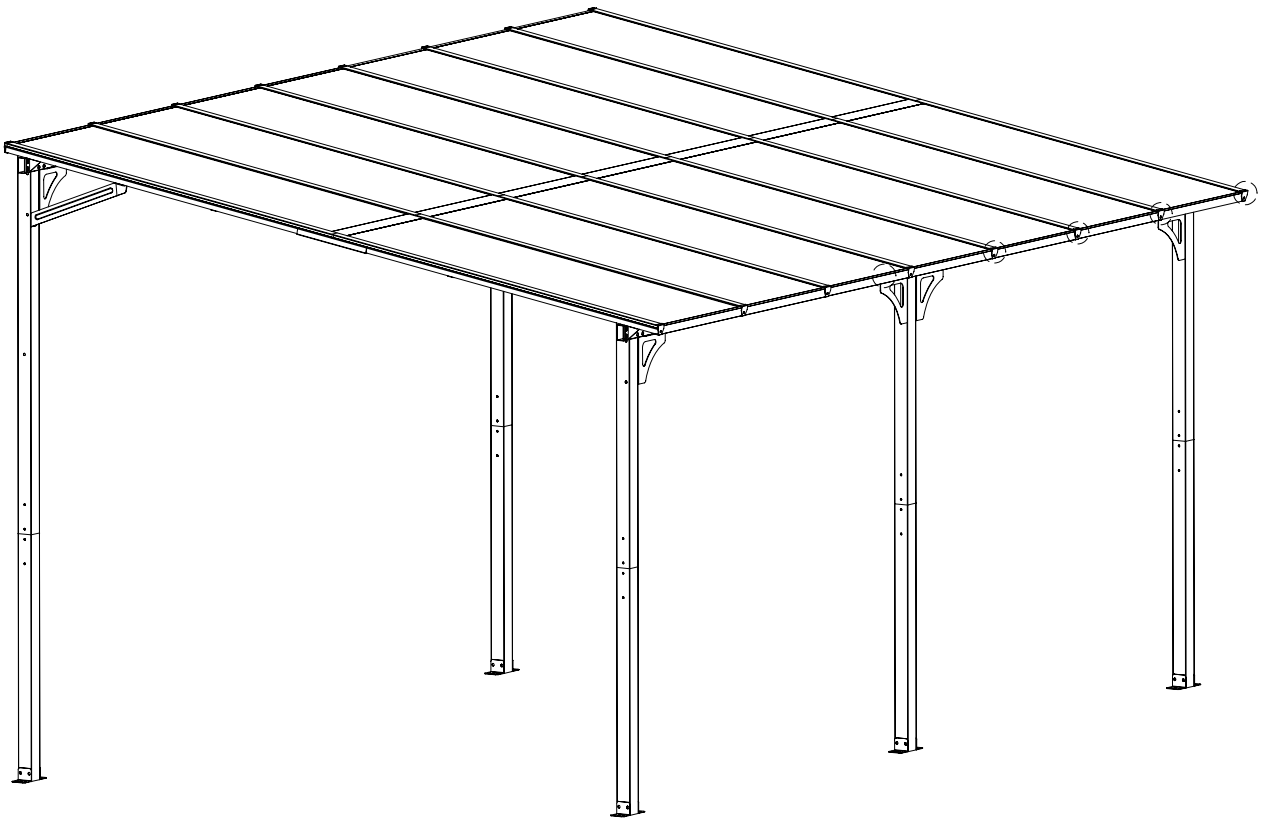

16

W  x6

