

AUDIO-VIDEO SHELVING

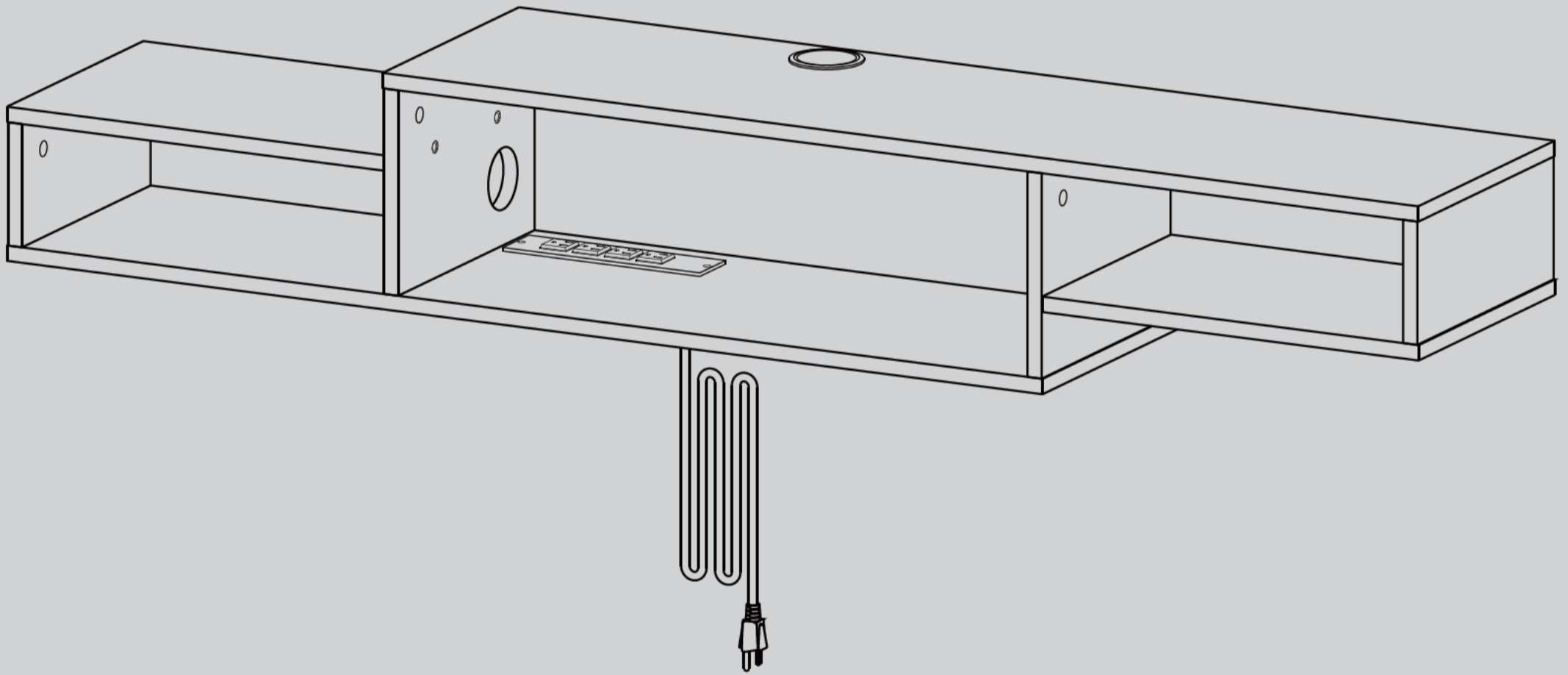

Thank you for choosing our products, please assemble and use it following the instructions.

Important

1. We recommend two people to assemble the product easier and faster.
2. Please DO NOT tighten the screws deeply during assembling avoiding that metal frame can be bent and plank will crack.
3. We recommend that all screws should not be tightened over during assembling to make it easy to adjust. When it is adjusted to proper station, all screws should be tightened.

Cam Lock Fastening System



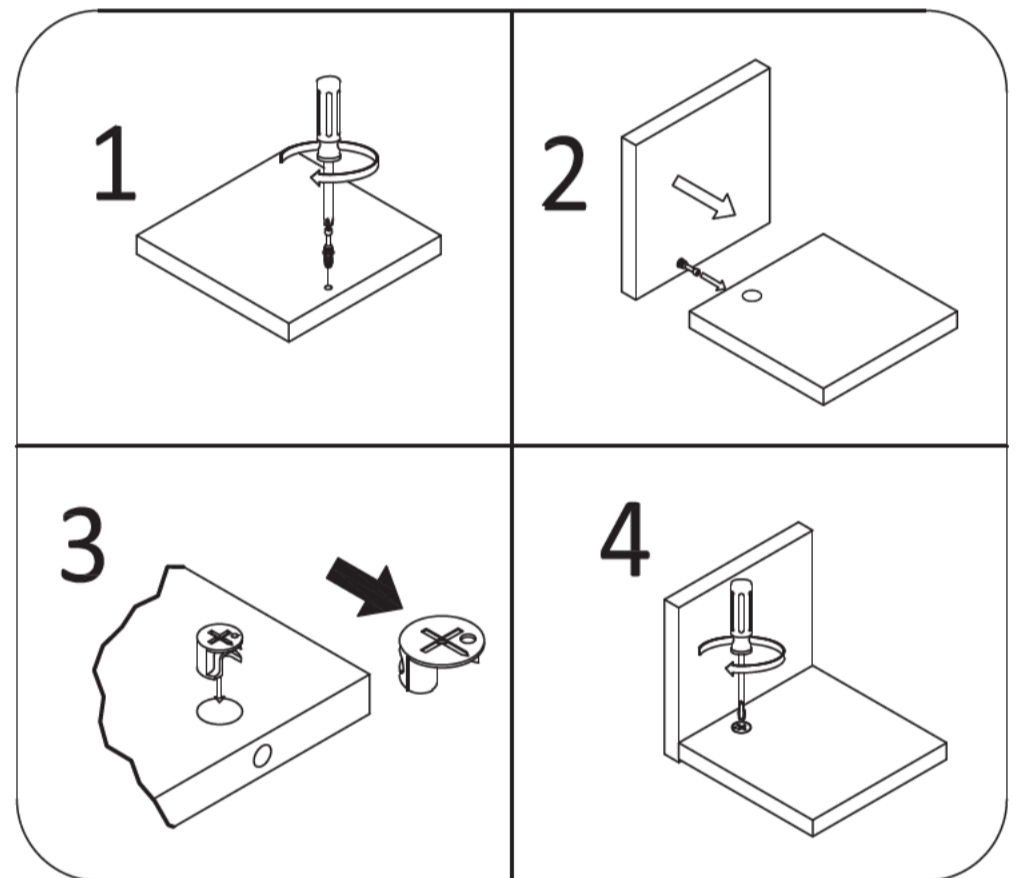
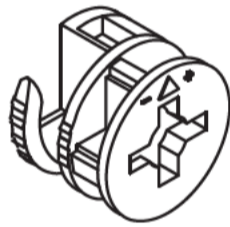



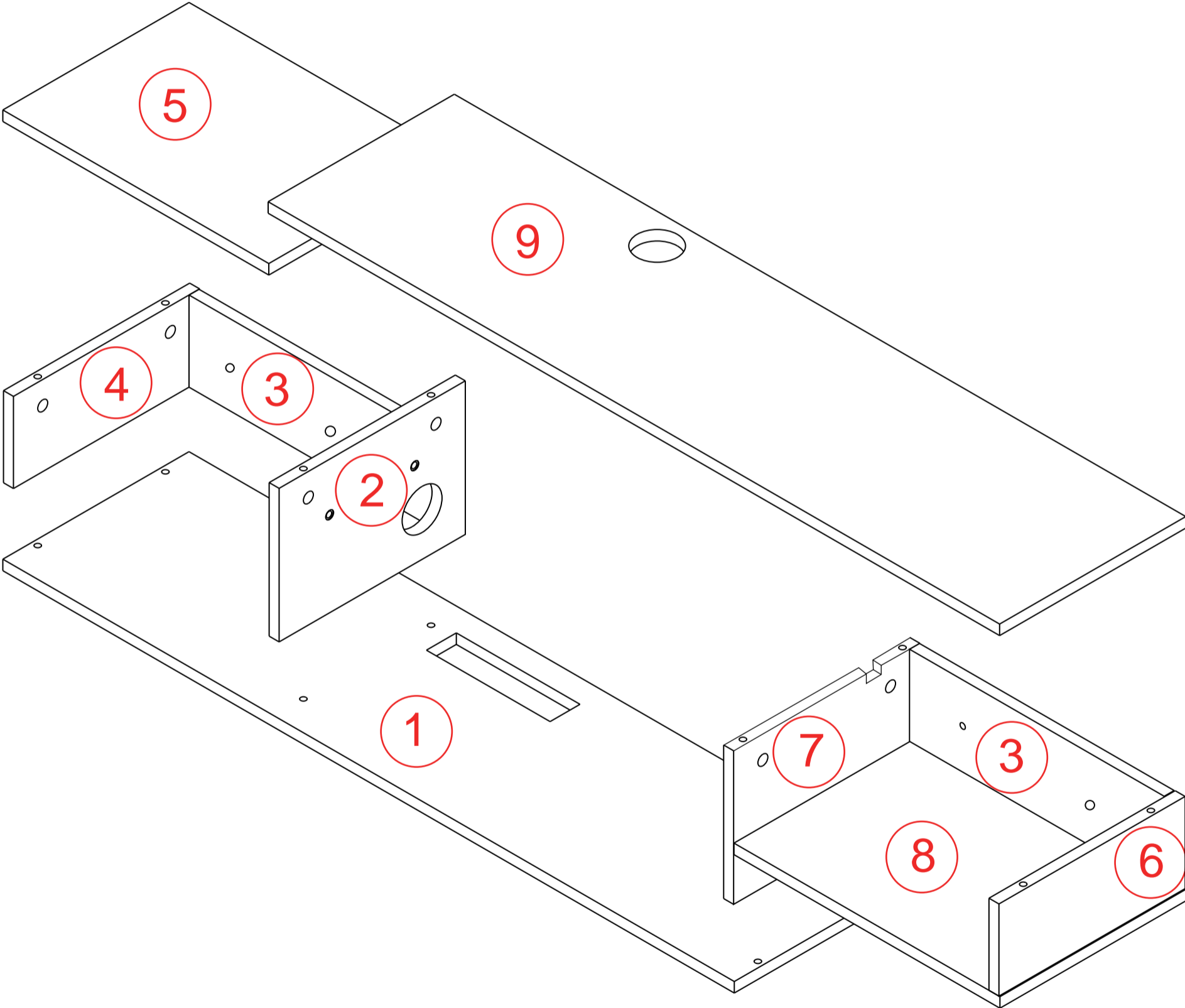



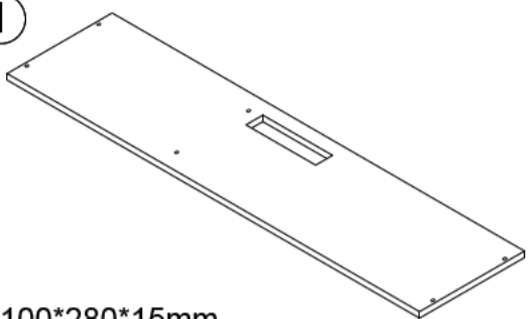
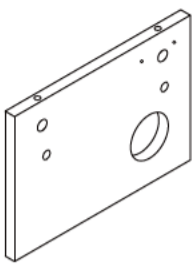
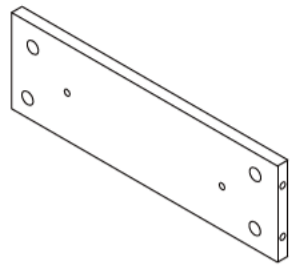
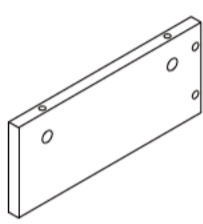
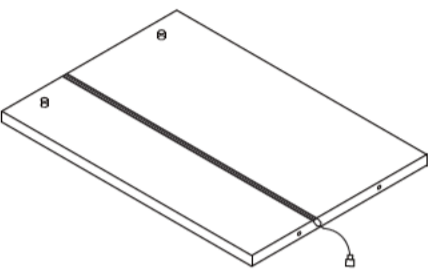
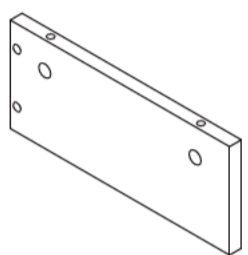
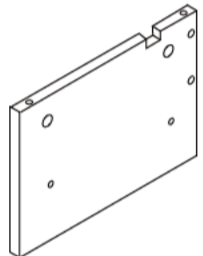
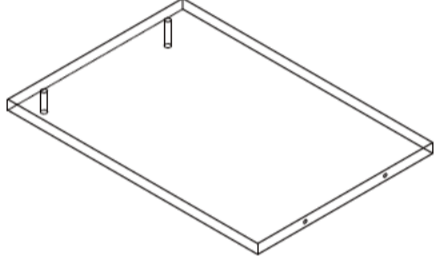
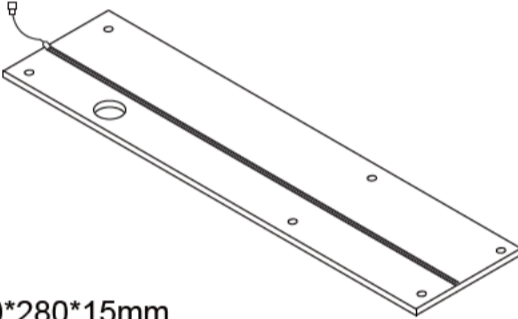

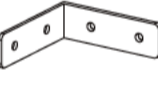

This Cam Lock Fastening System will be used throughout the assembly process

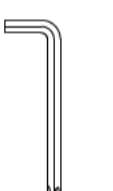
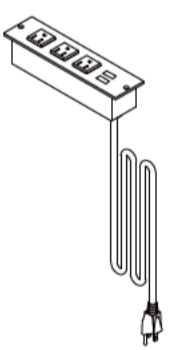

Exploded Drawing

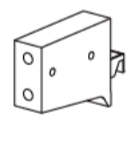
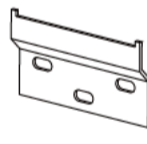

Parts

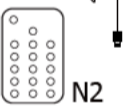
<p>①</p>  <p>1100*280*15mm</p>	<p>②</p>  <p>280*200*15mm</p>	<p>③</p>  <p>383*120*15mm</p> <p>2 pcs</p>						
<p>④</p>  <p>280*120*15mm</p>	<p>⑤</p>  <p>400*280*15mm</p>	<p>⑥</p>  <p>280*120*15mm</p>						
<p>⑦</p>  <p>280*200*15mm</p>	<p>⑧</p>  <p>400*280*15mm</p>	<p>⑨</p>  <p>1100*280*15mm</p>						
<p>A M6x45</p>  <p>x16+1</p>	<p>B</p>  <p>x16+1</p>	<p>C M7x50</p>  <p>x12+1</p>	<p>D Ø60</p>  <p>x1</p>	<p>F</p>  <p>x3</p>	<p>G M3.5x14</p>  <p>x8+1</p>	 <p>x1</p>	<p>E</p>  <p>x1</p>	<p>N1</p> 
<p>I M5x55</p>  <p>x16+1</p>	<p>J Ø6</p>  <p>x4+1</p>	<p>K Ø8x40</p>  <p>x16+1</p>	<p>L M3.5x30</p>  <p>x4+1</p>	<p>M1</p>  <p>x2</p>	<p>M2</p>  <p>x2</p>	<p>O</p>  <p>x1</p>	<p>N2</p> 	

The EXTRA ONE SCREW was provided to make sure your assembling.

Assembly Instructions

C M7*50



2 PCS

1

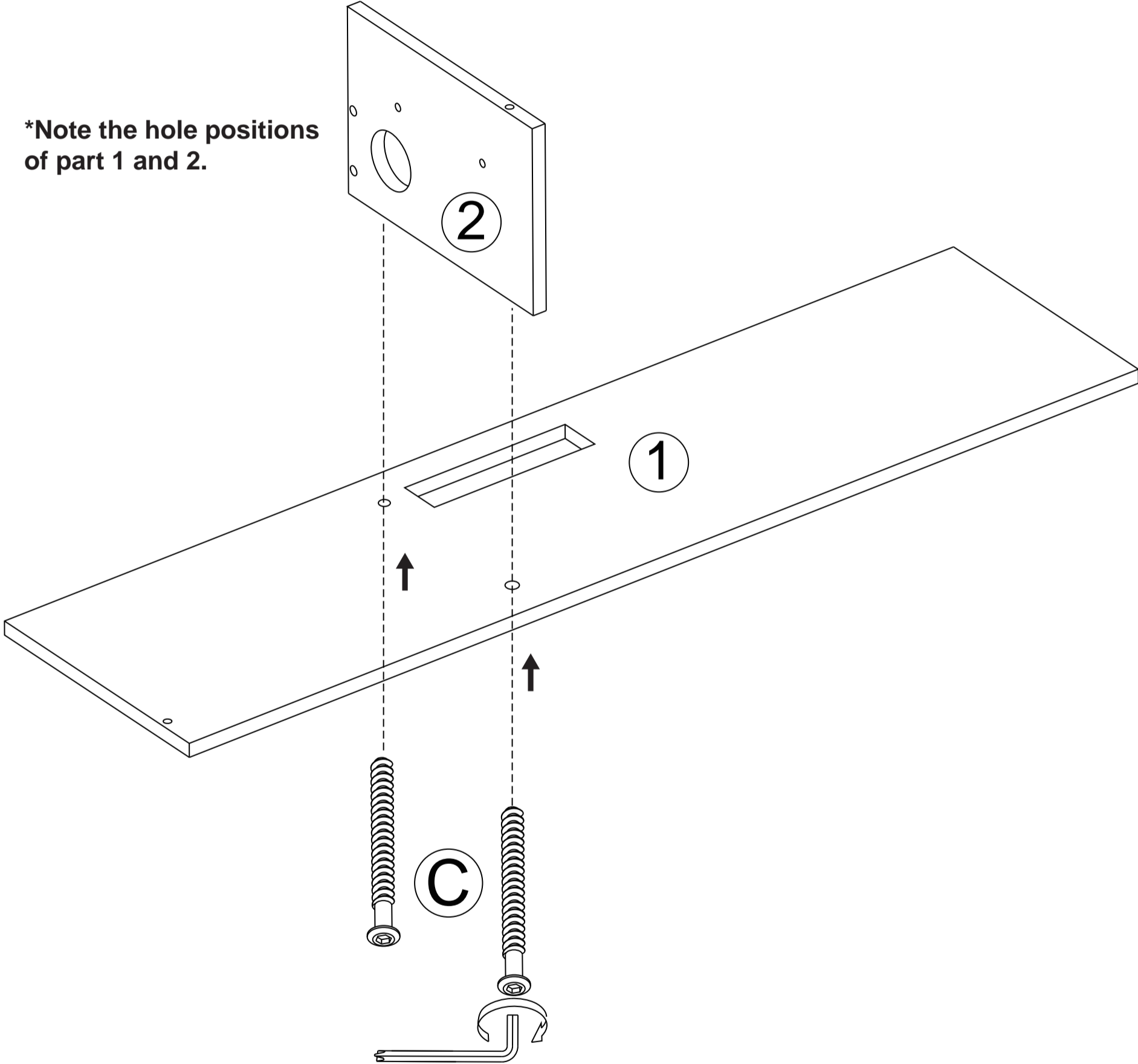

*Note the hole positions of part 1 and 2.



Connect part 1 to part 2 with C screws and tighten the screws.

Assembly Instructions

2

A	M6*45	B	M7*50
			
4 PCS		4 PCS	2 PCS

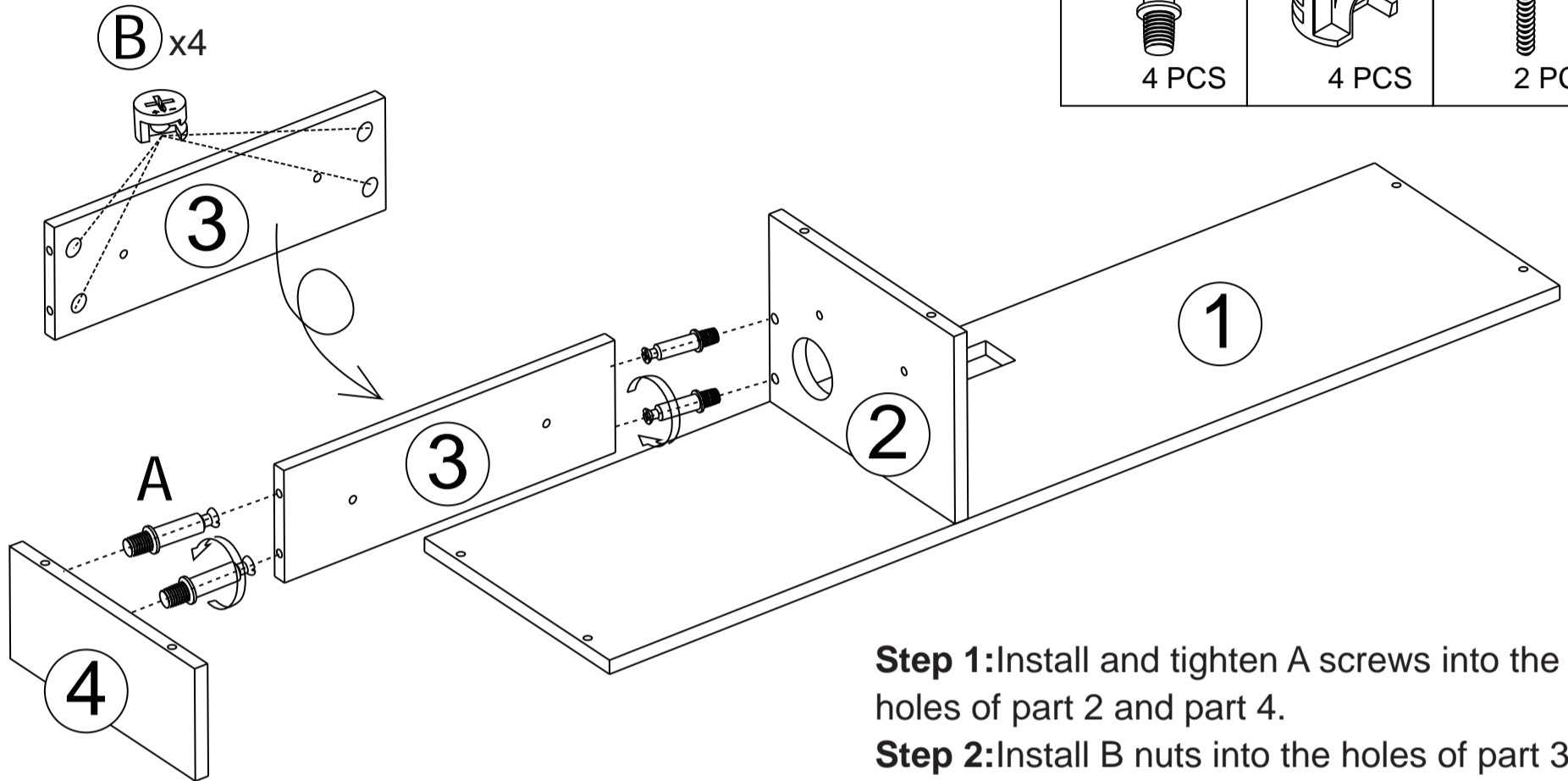

Step 1: Install and tighten A screws into the holes of part 2 and part 4.

Step 2: Install B nuts into the holes of part 3.

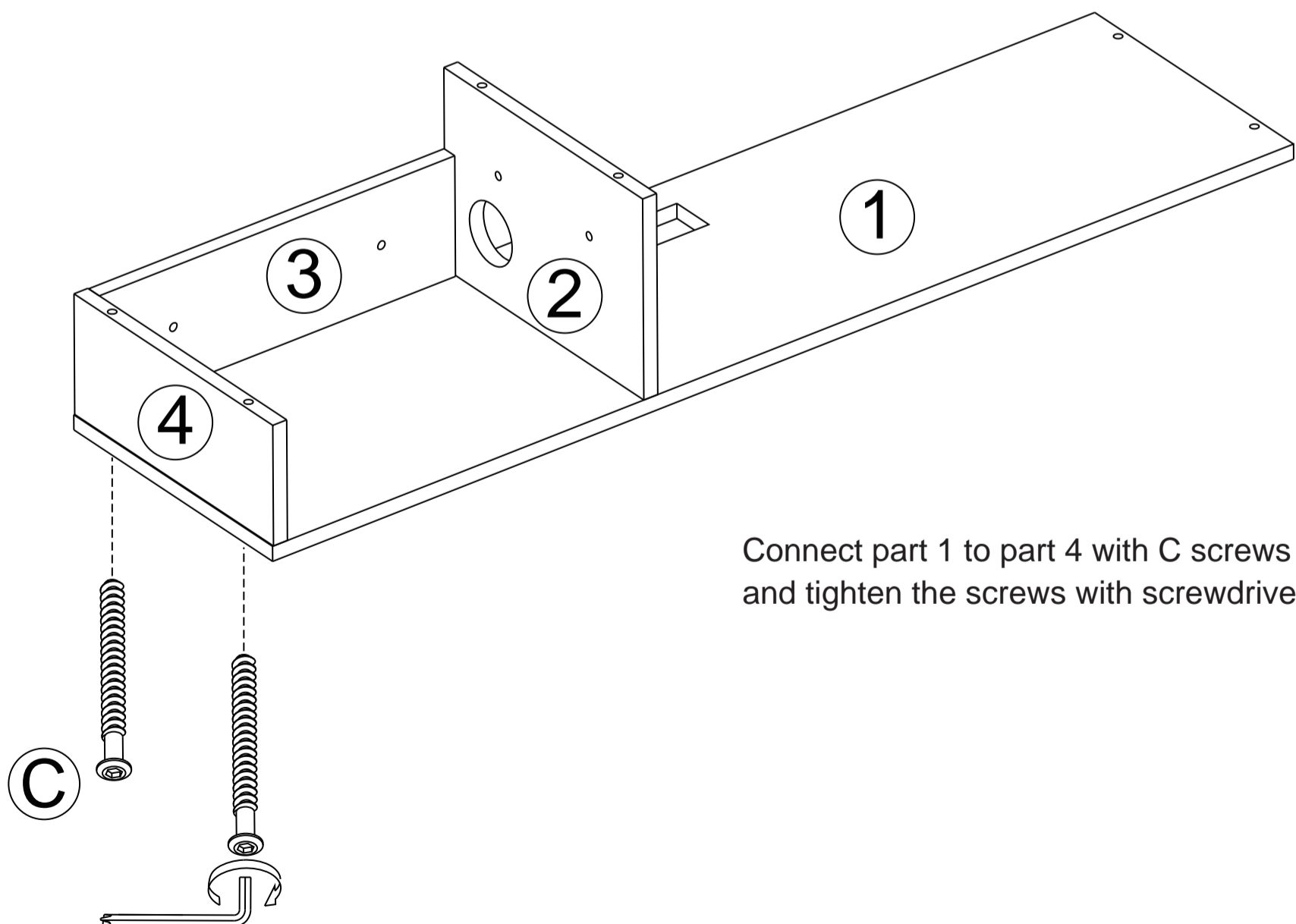

Step 3: Connect part 2, 3 and 4 as shown and tighten B nuts.



Connect part 1 to part 4 with C screws and tighten the screws with screwdriver.

Assembly Instructions

3

A	M6*45	B	M7*50
			
2 PCS		2 PCS	2 PCS

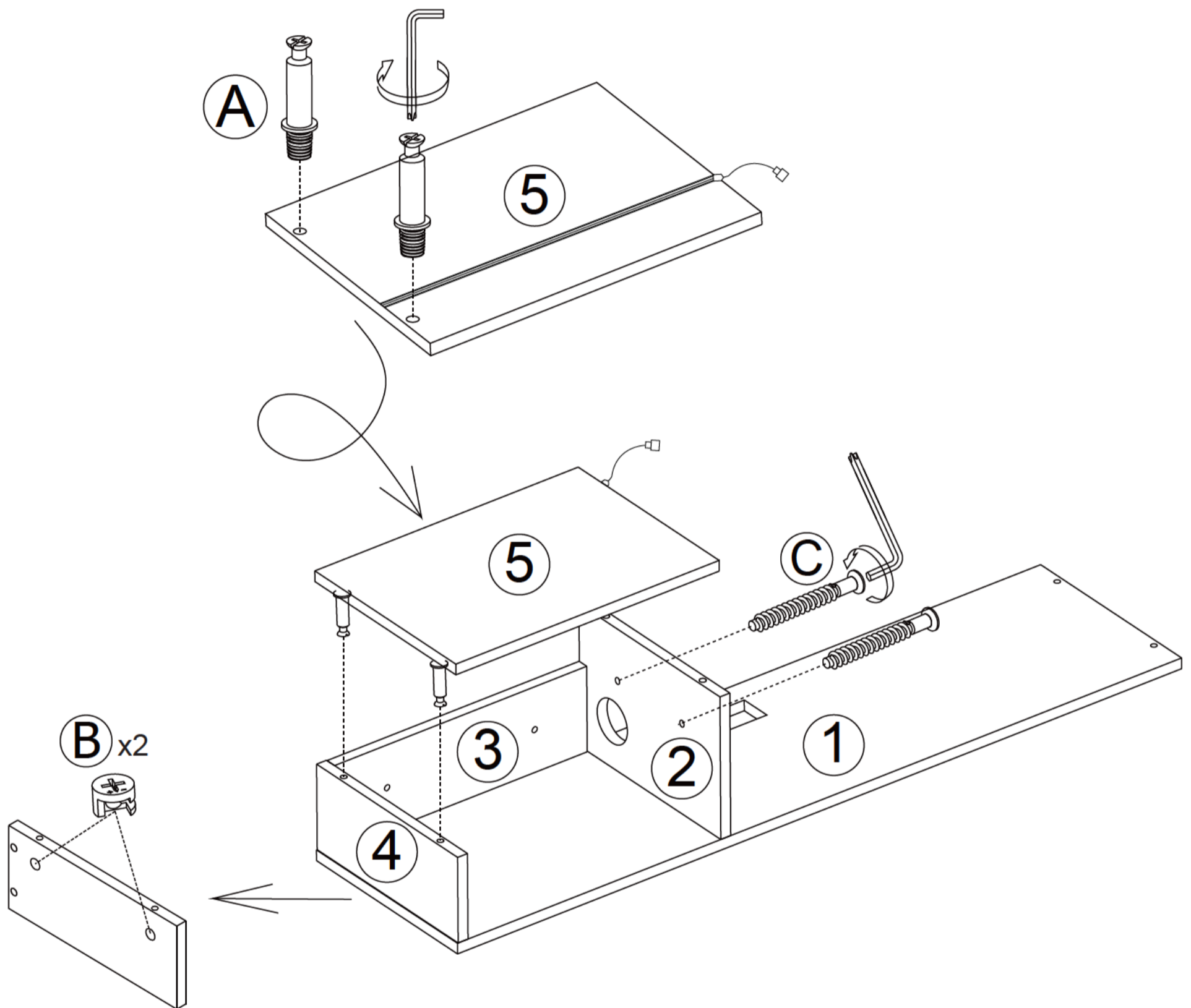

Step 1: Install and tighten A screws into the holes of part 5.



Step 2: Install B nuts into the hole of part 4.

Connect part 4 and 5 and tighten B nuts.

Step 3: Install C screws into the holes of part 2 as shown.

Assembly Instructions

4

A	M6*45	B
		
4 PCS		4 PCS

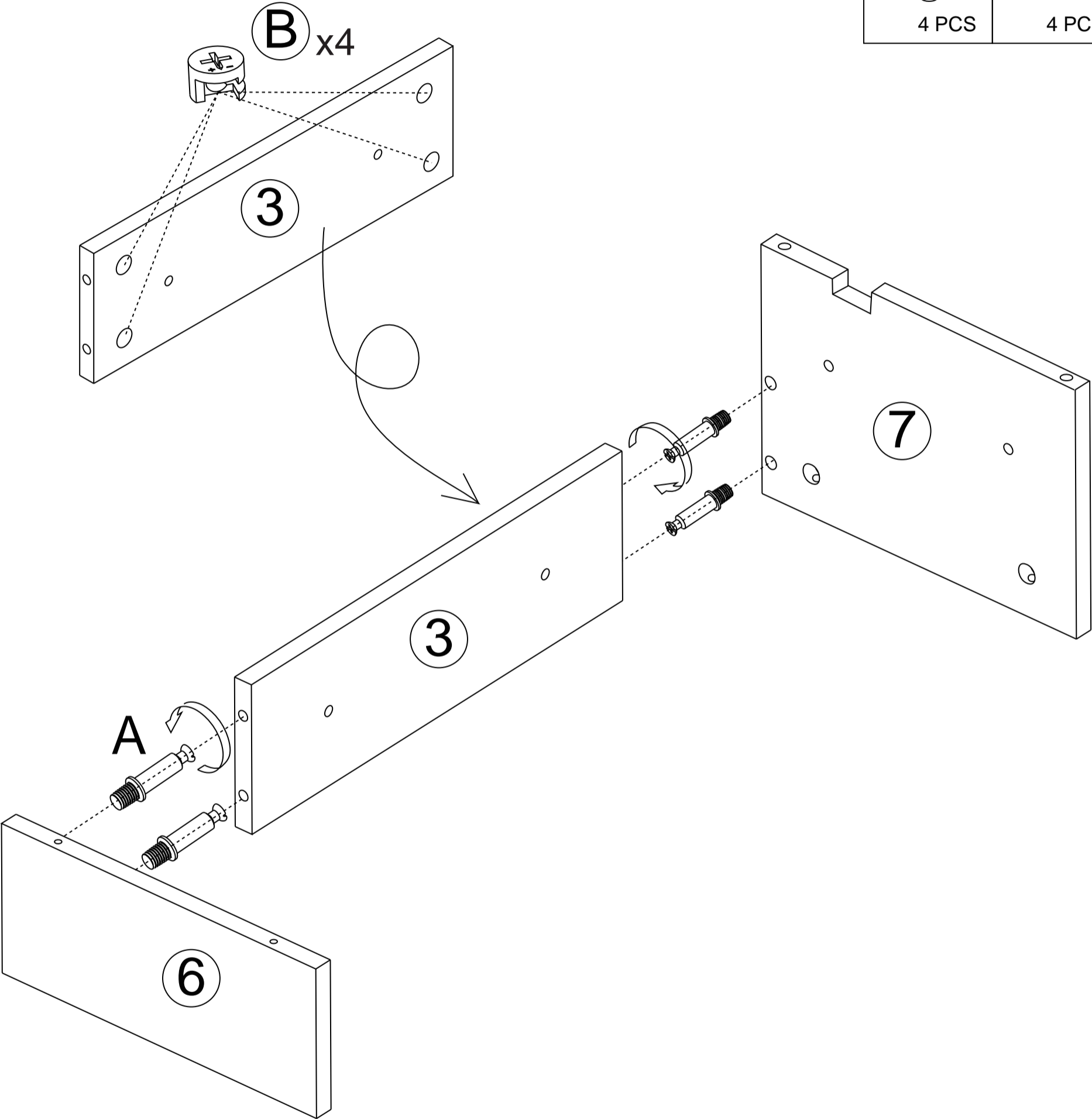

The diagram illustrates the assembly of three rectangular panels: part 3 (top), part 6 (bottom left), and part 7 (right). Part 3 is positioned at the top and has four holes. Part 6 is at the bottom left and has two holes. Part 7 is on the right and has four holes. Two screws, labeled 'A', are shown being inserted into the holes of parts 6 and 7. A nut, labeled 'B', is shown being placed on the end of each screw. Dashed lines indicate the alignment of the screws and nuts. A curved arrow points from the top view of part 3 down to the side view of the assembly, indicating the orientation of the part. The label 'B x4' is placed near the top view of part 3, indicating that four nuts are required. The label 'A' is placed near the screws being inserted into parts 6 and 7.

Step 1: Install and tighten A screws into the holes of part 6 and part 7.
Step 2: Install B screws into the holes of part 3.
Step 3: Connect part 3,6 and 7 as shown and tighten B nuts.

Assembly Instructions

5

C M7*50

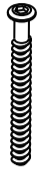

6 PCS

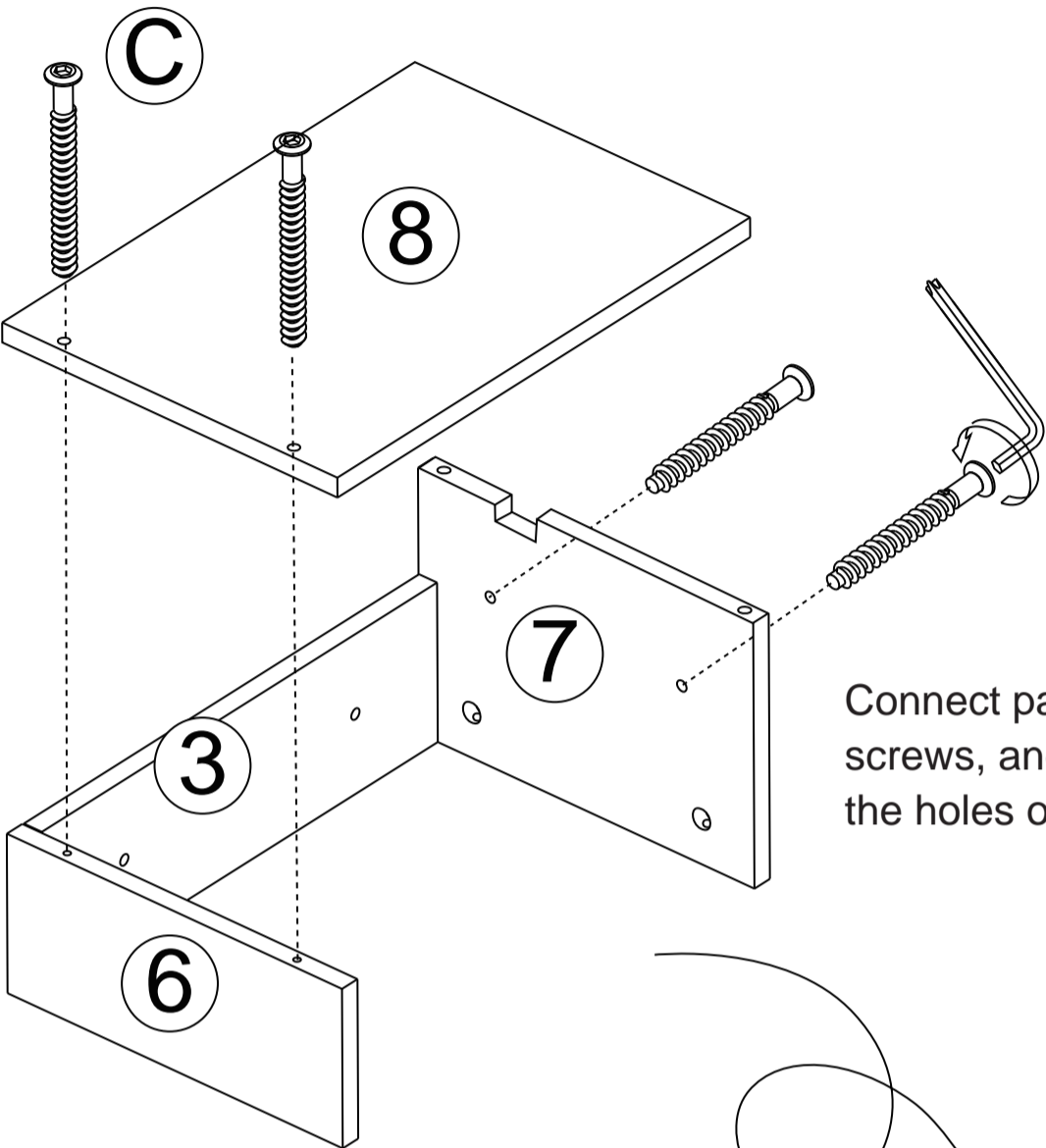

Connect part 6 and part 8 with C screws, and install C screws into the holes of part 7 as shown.

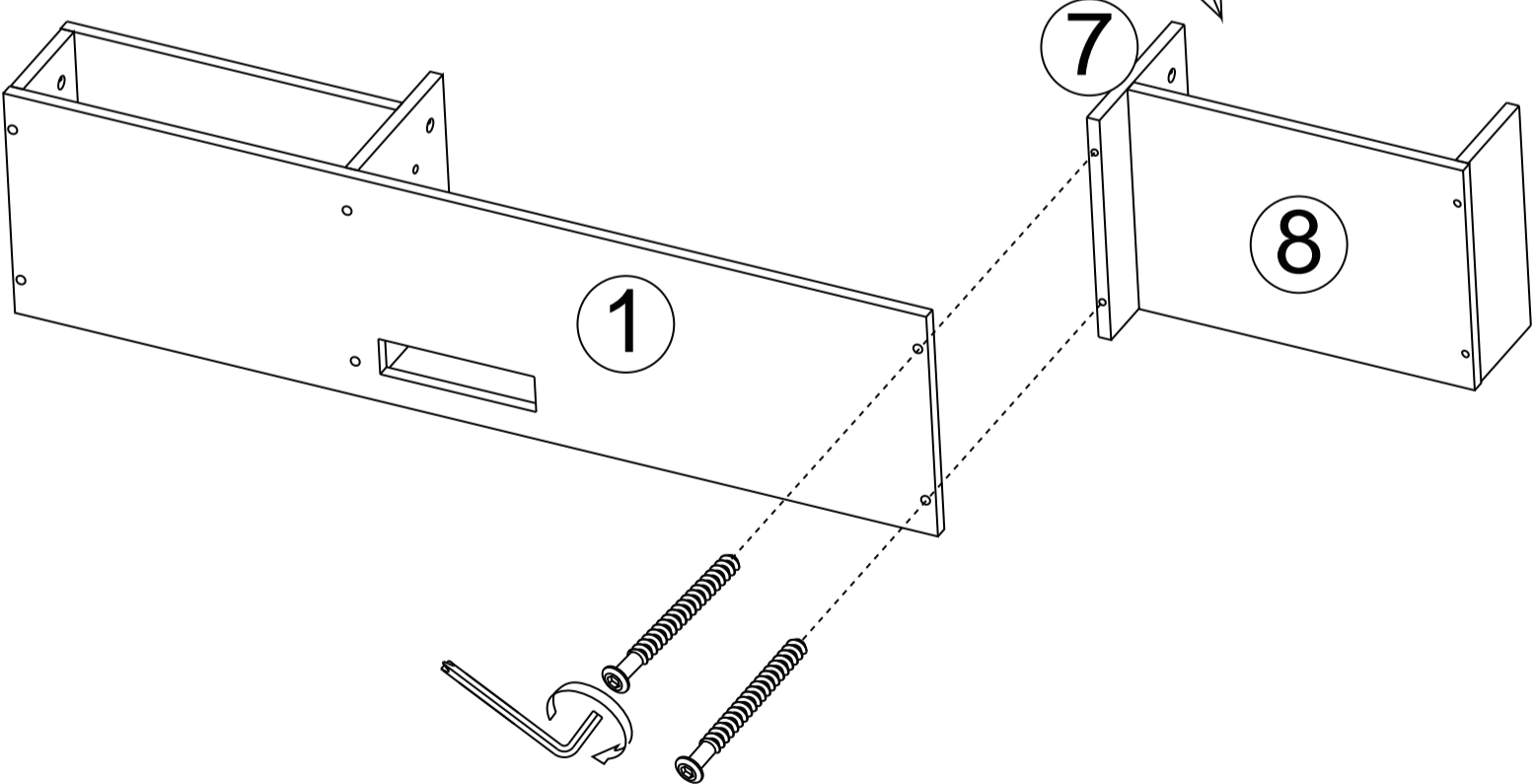

Connect part 7 and part 1 with C screws.

Assembly Instructions

6

G M3.5*14

E

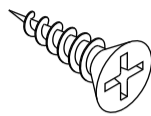

2 PCS

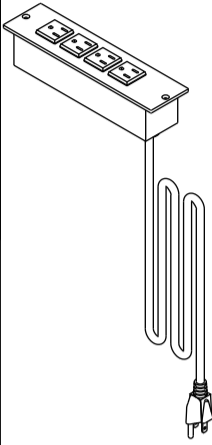

1 PCS

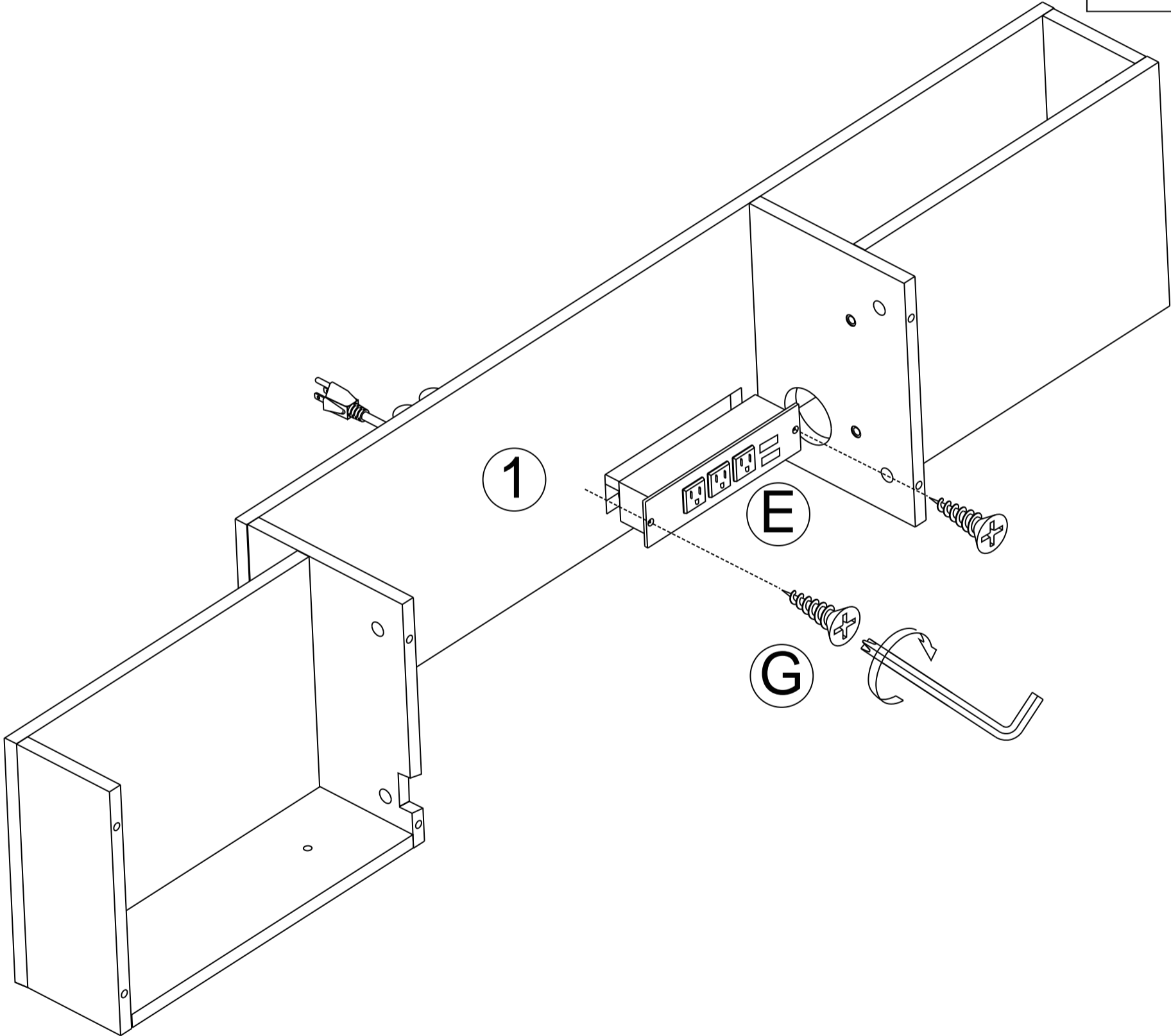

Put part E into the preformed hole of part 1 with G screws, and tighten the screws.

Assembly Instructions

7

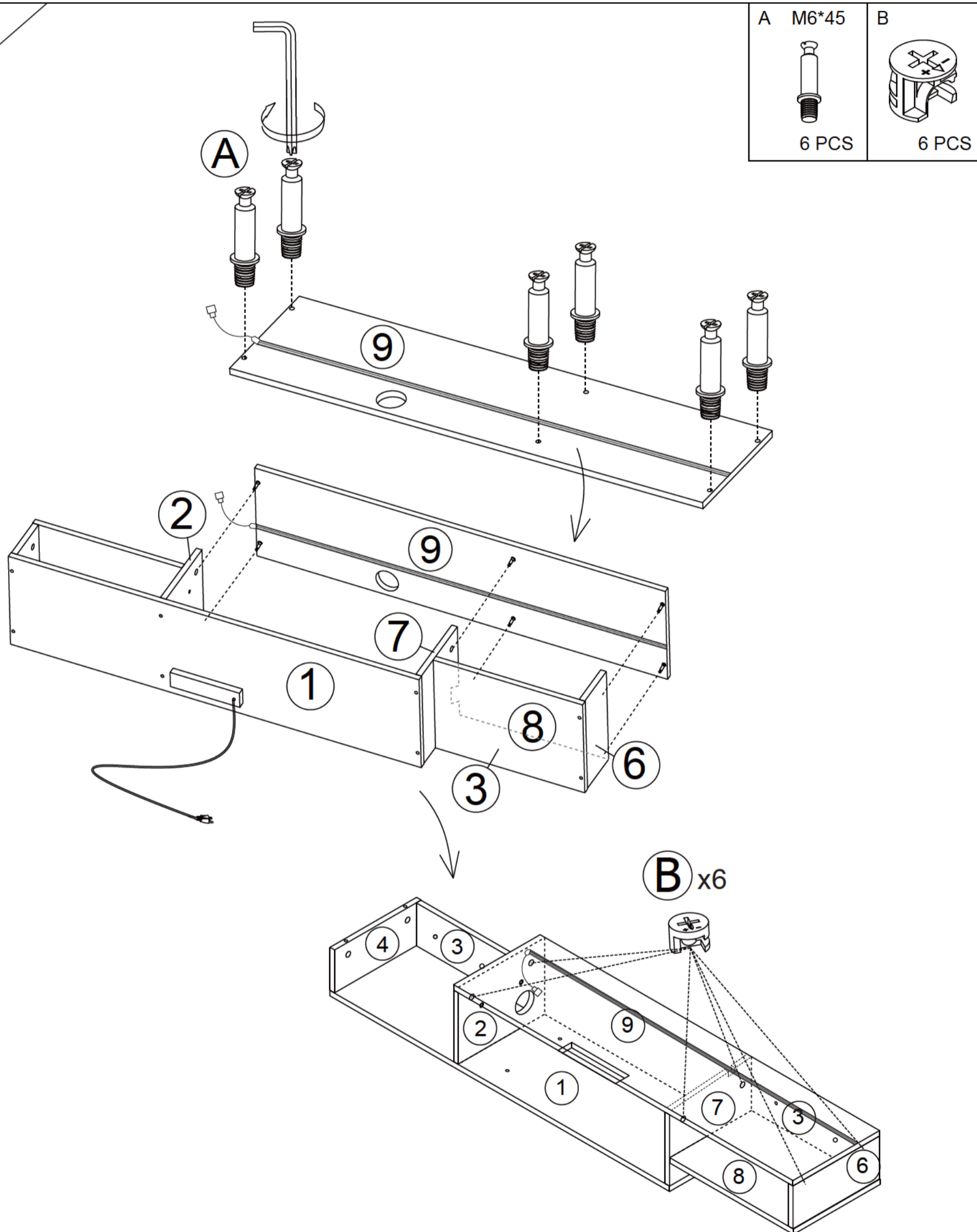

- Step 1:** Install and tighten A screws into the holes of part 9.
- Step 2:** Install B nuts into the bigger holes of part 2, 3 and 7.
- Step 3:** Connect part 2, 6, 7 and 9 as shown, and tighten B nuts.

Assembly Instructions

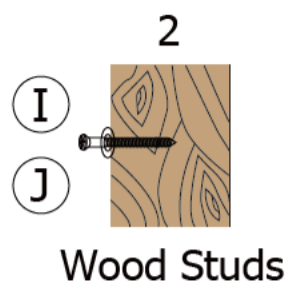
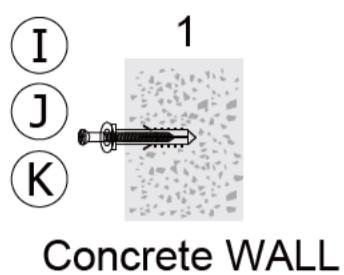

TIPS

- 1. The expansion screws are for concrete base.
- 2. The ordinary screws are for wooden base.

8

First way to install

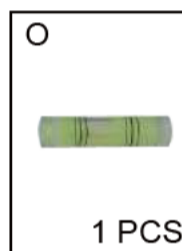
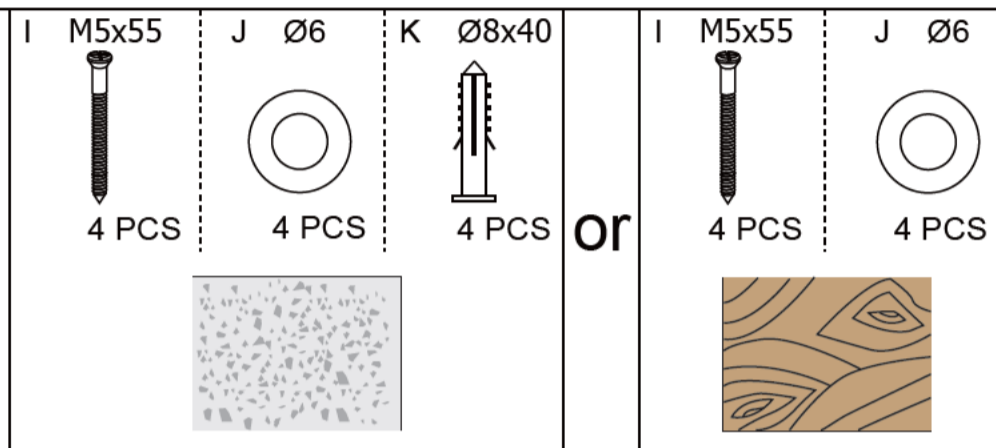



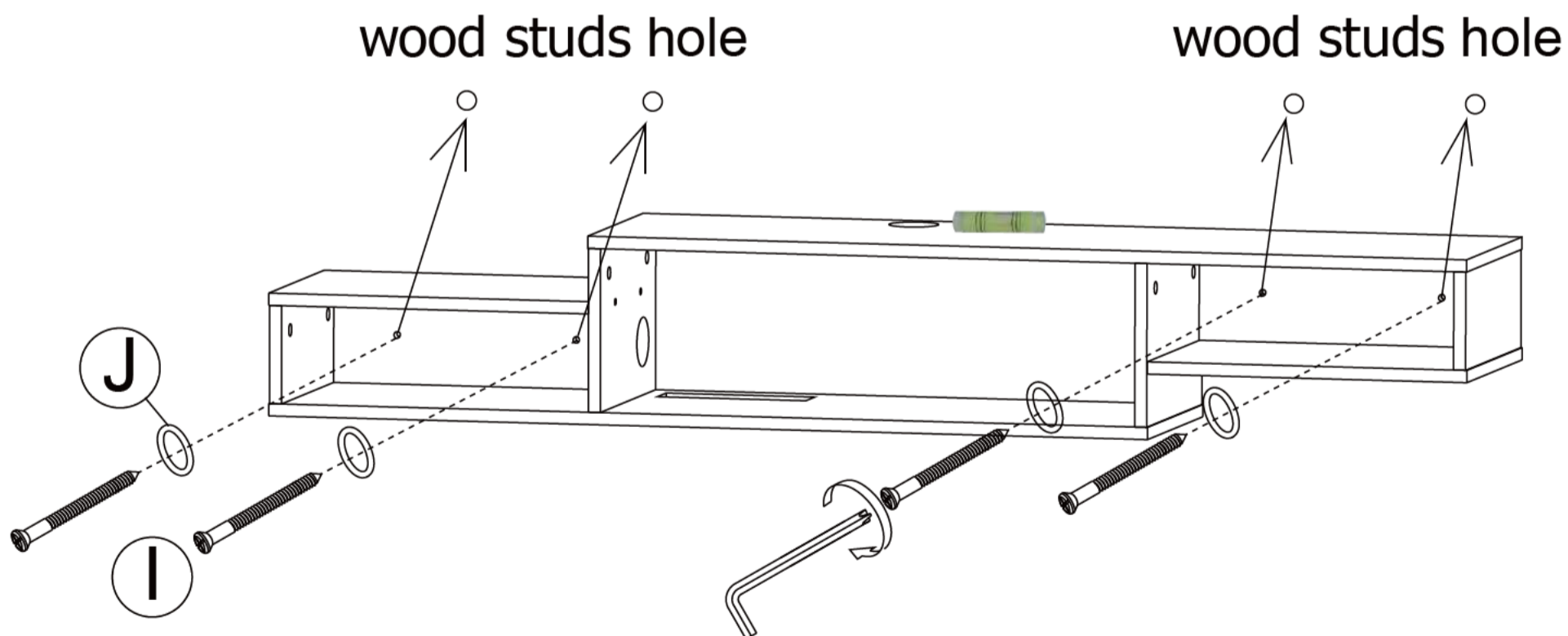

Find the horizontal position with part O on your concrete wall or wooden wall. Using the proper screws according to your wall to fix the shelving on the wall via 4 holes of part 3.





Assembly Instructions

9

Second way to install

I M5x55  6 PCS	K Ø8x40  6 PCS	or	I M5x55  6 PCS
			

M1  2 PCS	M2  2 PCS
----------------------------------------------------------------------------------------------------	----------------------------------------------------------------------------------------------------

L M3.5x30  4 PCS

O  1 PCS

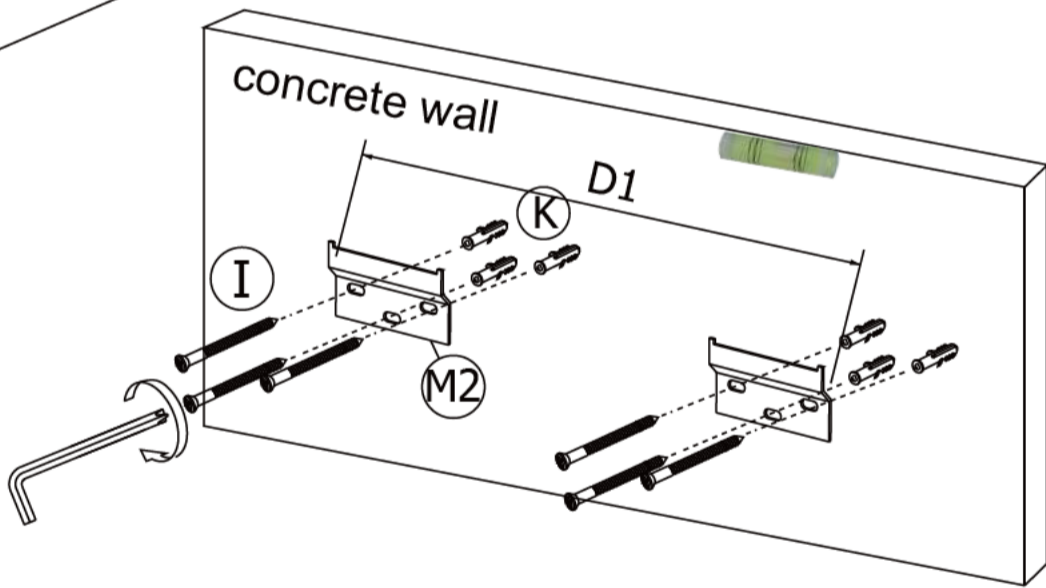
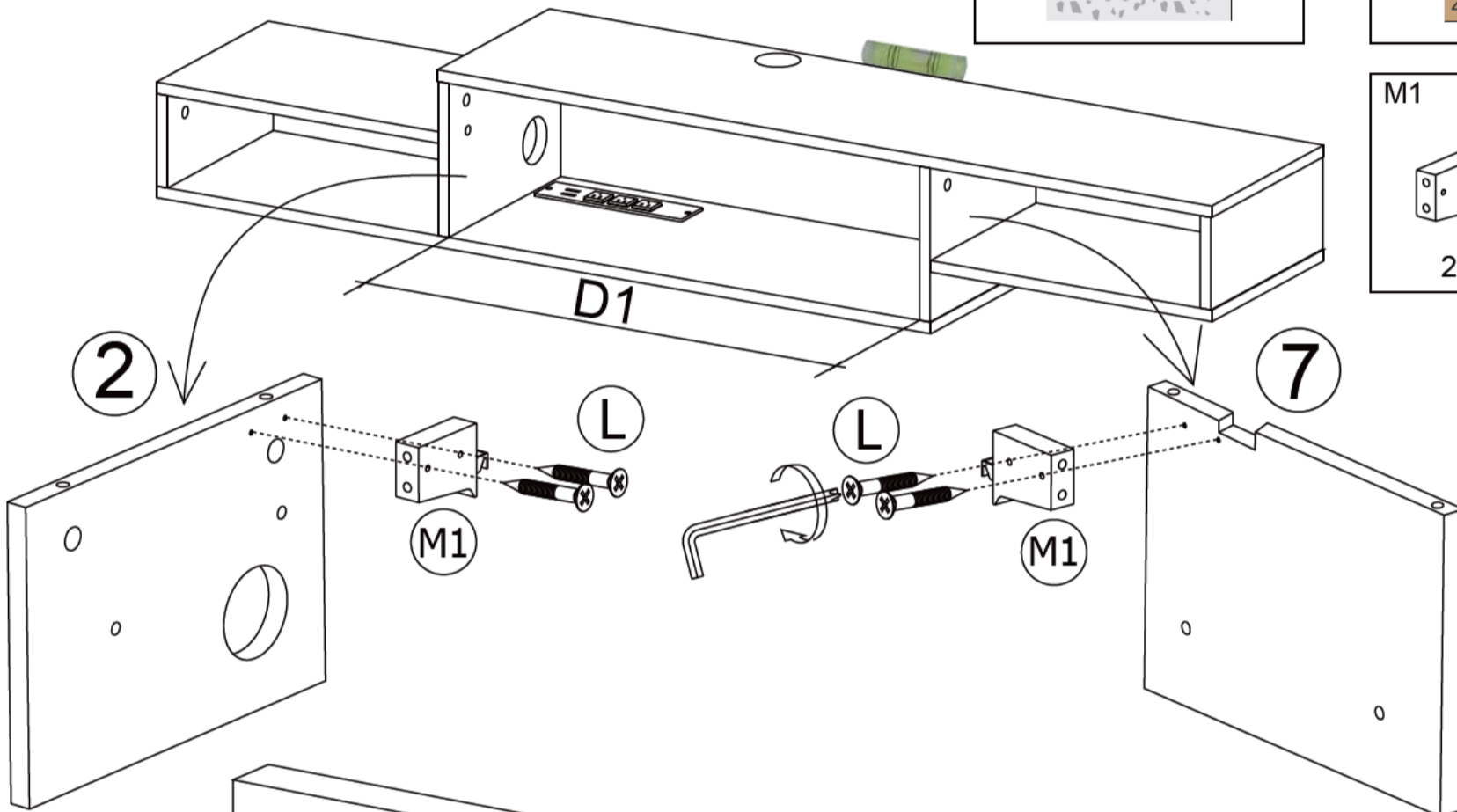

Install part M2 on the wall with the proper screws on a horizontal position. Install part M1 on the side of part 2 and part 7 with L screws.

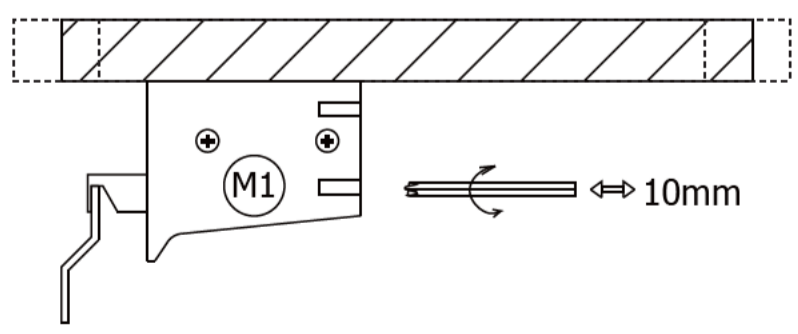
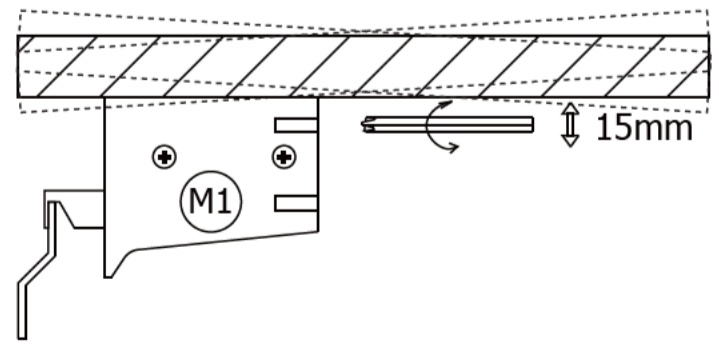

* Hang the shelving on the wall via connecting M1 and M2. Adjust the part M to make it a horizontal position according to the part O.

Assembly Instructions

10

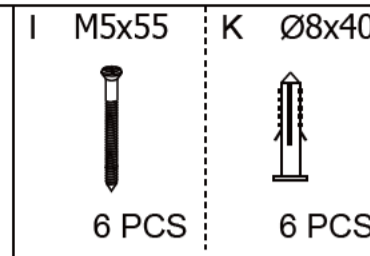
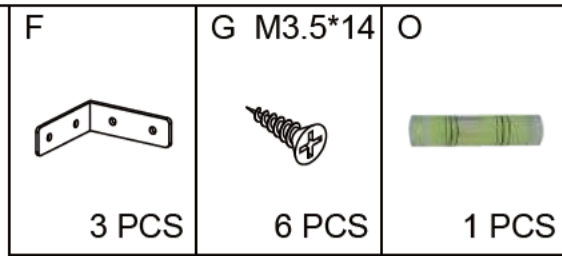

or

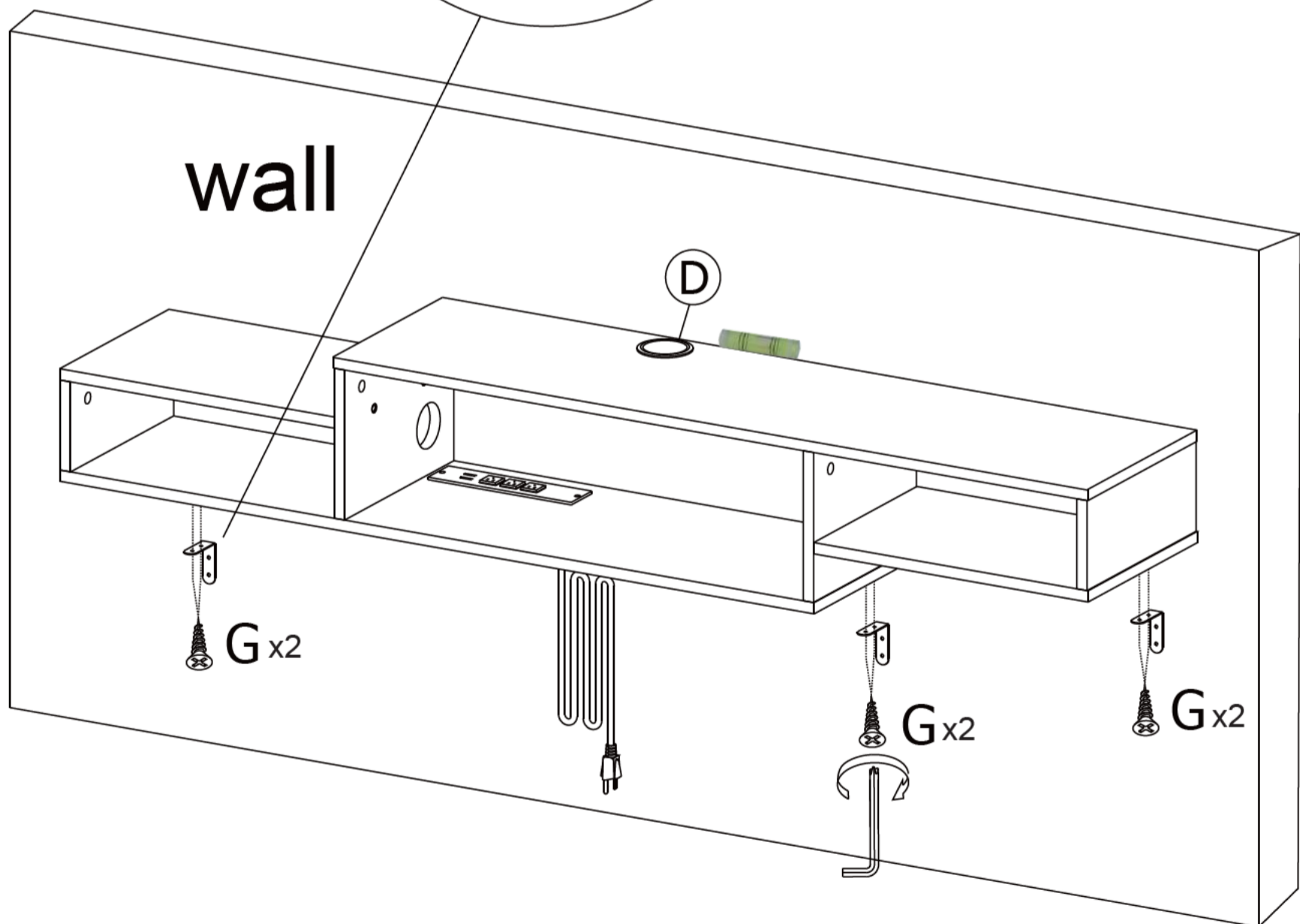
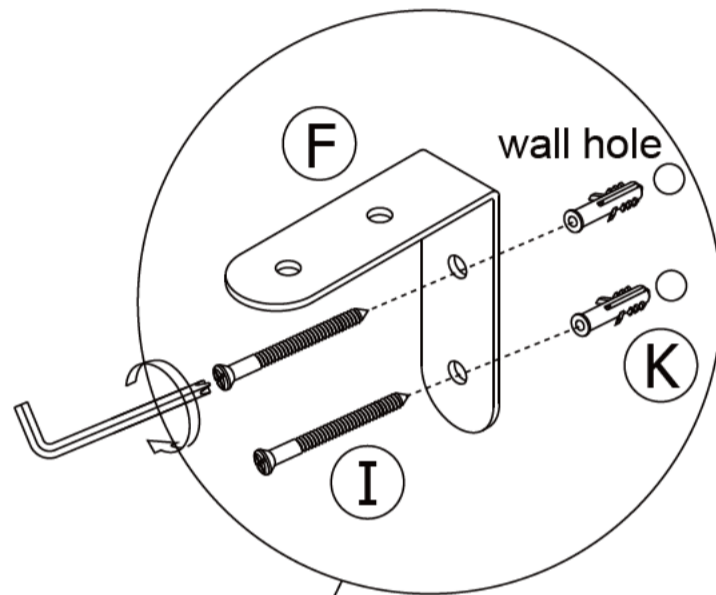
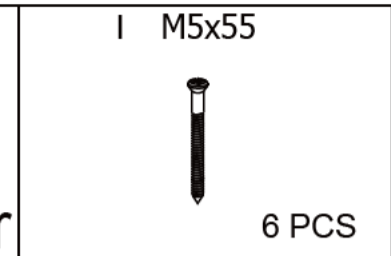

* After adjusting Audio-Video Shelving in a horizontal position, install part F with G screws to enhance the stability.

Assembly Instructions

11

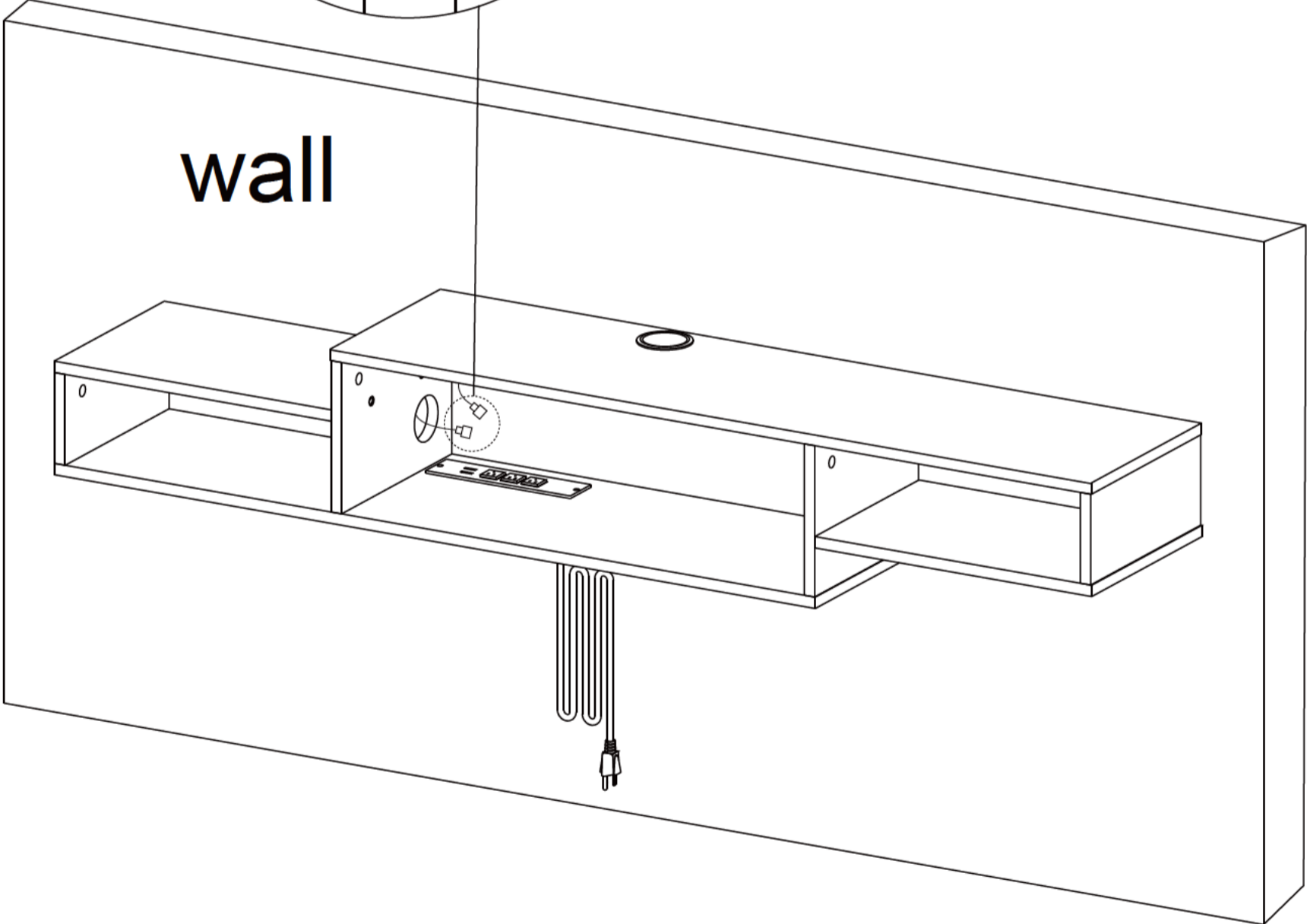
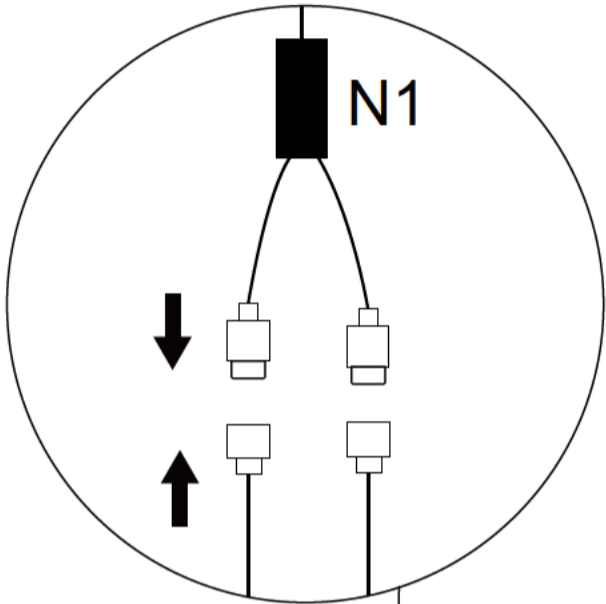
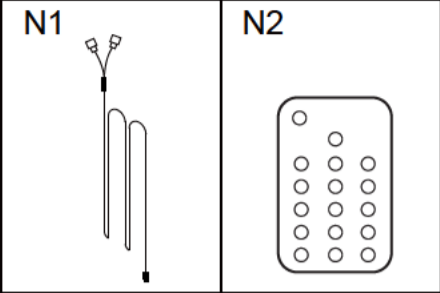

GENERAL GUIDELINES

- Please read the following instructions carefully and use the product accordingly.
- Please keep this instruction and hand it over when you transfer the product.
- This summary may not include every detail of all variations and considered steps.
- Please contact us when further information and help are needed.

NOTES

- The product is intended for normal use only. The seller does not assume any responsibility or liability with respect to any damage caused by incorrect assembly or improper use.
- Keep away from exposure and heat sources. Place it in a dry area to avoid peeling or fading.
- Please check if there is any welding spatter or debris when you receive the product. If there are defective or missing parts after unpacking, please contact us immediately. Use soft cloth and neutral detergent to wipe it clean, then wipe dry. Do not use an abrasive agent to wipe the product.

WARNINGS

- During assembly, keep small parts out of the reach of children. It may be fatal if swallowed or inhaled.
- To avoid potential danger of suffocation, keep all parts and packaging (films, plastic bags and foam, etc.) away from babies and children.
- Keep away from sharp or corrosive items to avoid potential product damage or bodily injury.

EINLEITUNG

- Bitte lesen Sie die folgende Anleitung aufmerksam durch und verwenden Sie das Produkt sachgemäß.
- Bewahren Sie diese Anleitung gut auf und händigen Sie sie bei Weitergabe des Produkts an Dritte ebenfalls mit aus.
- Aus Gründen der Übersicht können nicht alle Details zu allen Varianten und denkbaren Montagen beschrieben werden. Wenn Sie weitere Informationen und Hilfe benötigen, kontaktieren Sie uns bitte.

HINWEISE

- Das Produkt ist nur für die Verwendung im Innenbereich vorgesehen. Montieren und verwenden Sie das Produkt nur wie in dieser Anleitung beschrieben. Eine andere Verwendung als beschrieben, oder eine Veränderung/ein Umbau des Produkts ist nicht erlaubt und kann zu Verletzungen und/oder Beschädigungen des Produkts führen. Der Händler übernimmt keine Haftung für Schäden, die durch unsachgemäßen Gebrauch oder falsche Montage entstanden sind.
- Nach Erhalt des Produkts überprüfen Sie es bitte, und stellen Sie sicher, dass kein Schweißschlacke oder Splitter vorhanden ist.
- Das Produkt darf nicht benutzt werden, wenn Teile beschädigt sind oder fehlen. Ansonsten könnten Schäden entstehen.
- Beim Zusammenbauen schrauben Sie bitte zuerst alle Schrauben nicht fest an, erst nach dem Aufbau ziehen Sie sie fest an.

- Bitte überprüfen Sie regelmäßig den Zustand der Schraubenbefestigung, da es das Risiko gibt, dass einige Schrauben beim Gebrauch gelöst werden. Stellen Sie sicher, dass alle Schrauben immer fest sind, um ein Umkippen beim Gebrauch zu vermeiden.

WARNHINWEIS

- Halten Sie Kinder während der Montage vom Arbeitsbereich fern. Zum Lieferumfang gehören eine Vielzahl von Schrauben und anderen Kleinteilen. Diese können beim Verschlucken oder Inhalieren lebensgefährlich sein.
- Lassen Sie keine Kinder auf den Artikel klettern, oder an dem Artikel spielen, um die Umkippgefahr zu vermeiden.
- Zur Vermeidung der Erstickungsgefahr halten Sie die Verpackungsmaterialien wie Kunststoff-Verpackungstüten von Babys und Kindern fern.
- Vermeiden Sie generell jeden Kontakt mit spitzen Gegenständen und aggressiven Substanzen, um das Produkt vor Beschädigung zu schützen, und seine Sicherheit zu schützen.

FR

INTRODUCTION

- Lisez attentivement ces notes et utilisez votre produit conformément au présent mode d'emploi.
- Obéissez à ces instructions. Si vous voulez mettre ce produit à la disposition de tiers, veuillez joindre ce mode d'emploi.
- Par souci de clarté, les détails concernant chaque variante ou montage envisageable ne peuvent être tous décrits. Si vous avez besoin de plus d'informations ou si vous rencontrez certains problèmes non traités de manière détaillée dans ces instructions, veuillez nous contacter.

NOTES

- Le produit doit être installé et utilisé conformément à ce mode d'emploi. Les utilisations qui ne correspondent pas à la description ci-dessus ou les modifications de l'article ne sont pas autorisées. Le vendeur n'est responsable d'aucun dommage résultant de l'installation incorrecte ou de l'utilisation non conforme.
- Veuillez vérifier attentivement avant l'installation pour vous assurer qu'il n'y a pas de résidus de soudure ou de débris.
- Il est interdit d'utiliser des produits endommagés ou perdus, sinon, il y aura un risque de blessure.
- Lors de l'installation, veuillez positionner et ajuster correctement toutes les vis et les écrous, ensuite serrez progressivement l'ensemble des vis.
- Il est recommandé d'examiner périodiquement les vis qui pourraient se relâcher progressivement pendant l'utilisation, ce qui risque de provoquer des dommages causés par un renversement du produit. Veuillez donc vous assurer que les vis sont bien serrées.
- Pour l'entretien quotidien, utilisez un chiffon doux et sec. Si nécessaire, vous pouvez utiliser un produit détergent à pH neutre. Ne jamais essuyer la surface avec un chiffon mouillé ou un matériau dur.

AVERTISSEMENTS

- Il est interdit aux enfants de participer à l'assemblage du produit car il comprend de nombreuses petites pièces et l'aspiration ou l'ingestion de ces pièces présente un risque mortel.
- Pour éviter le danger inattendu (par exemple, asphyxie), éloignez les enfants de tous.
- les composants et emballages (films, sac en plastique, polystyrènes, etc.) . Eloignez les objets aigus ou corrosifs du produit afin d'éviter les dommages possibles.

LINEE GUIDA GENERALI

- Leggere attentamente le seguenti istruzioni e usare il prodotto in modo opportuno.
- Conservare questo manuale e consegnarlo quando il prodotto cambia proprietario.
- Questo estratto potrebbe non includere ogni dettaglio di tutte le modifiche e le fasi considerate. Contattarci se hai bisogno di ulteriori informazioni e assistenza.

NOTE

- Il venditore non si assume alcuna responsabilità per quanto riguarda danni causati da montaggio scorretto o uso improprio.
- Controllare che non ci siano schizzi o residui di saldatura quando ricevi il prodotto.
- Nel caso in cui ci siano parti difettose o mancanti, contattare immediatamente l'assistenza clienti.
- Durante il processo di assemblaggio, serrare a metà le viti fino a quando il telaio non è completo, quindi serrarle completamente.
- Pulire con un panno morbido e un detergente neutrale e asciugare con un panno asciutto. Non utilizzare detersivi abrasivi per pulire il prodotto.

AVVERTENZE

- Durante l'assemblaggio, tenere le parti di piccole dimensioni lontano dai bambini. Potrebbero essere letali in caso di ingestione o inalazione.
- Tenere tutte le componenti e i materiali d'imballaggio (pellicole, sacchetti di plastica, polistirolo, ecc.) lontani dai bambini per prevenire il rischio di soffocamento.
- Tenere lontano da oggetti appuntiti o corrosivi per evitare potenziali danni al prodotto o lesioni.

ACERCA DEL MANUAL

- Por favor, lea detenidamente las instrucciones y respete los debidos usos del producto.
- Por favor, conserve bien este manual y en caso de cesión, no olvide entregarlo junto con el producto.
- No es posible que se presenten todos los detalles y pasos de montaje en las instrucciones. Si necesita ayuda o información adicional, póngase en contacto con nosotros.

NOTAS

- Ha de montarse y utilizarse el producto paso a paso siguiendo estrictamente las instrucciones.
- De lo contrario, el vendedor no asumirá ninguna responsabilidad por los daños y lesiones causados por el montaje y los usos inadecuados.
- Después de recibir el producto, por favor compruebe atentamente para asegurar que no haya desechos de soldaduras ni pedacitos.
- Si hay las piezas perdidas o dañadas, no utilice el producto, de lo contrario, existirá el peligro de lesiones.
- No apriete totalmente ningún tornillo durante el montaje, una vez terminado el montaje, apriete completamente todos los tornillos.

- Inspeccione regularmente los tornillos. Durante el uso, los tornillos se podrán aflojar, causará daños al producto, por eso asegure que todos los tornillos estén bien apretados.

ADVERTENCIAS

- Debido a que existen múltiples tornillos y otras piezas pequeñas, no permita que se acerquen los niños por el riesgo de asfixia producida por tragar alguna pieza.
- Guarde el embalaje fuera del alcance de los niños para evitar el peligro de asfixia.
- No deje que el producto conecte con los objetos puntiagudos ni los productos químicos para evitar causar daños o lesiones.

EN

GENERAL GUIDELINES

- Please read the following instructions carefully and use the product accordingly.
- Please keep this instruction and hand it over when you transfer the product.
- This summary may not include every detail of all variations and considered steps.
- Please contact us when further information and help are needed.

NOTES

- The product is intended for normal use only. The seller does not assume any responsibility or liability with respect to any damage caused by incorrect assembly or improper use.
- Keep away from exposure and heat sources. Place it in a dry area to avoid peeling or fading.
- Please check if there is any welding spatter or debris when you receive the product.
- If there are defective or missing parts after unpacking, please contact us immediately. Use soft cloth and neutral detergent to wipe it clean, then wipe dry. Do not use an abrasive agent to wipe the product.

WARNINGS

- During assembly, keep small parts out of the reach of children. It may be fatal if swallowed or inhaled.
- To avoid potential danger of suffocation, keep all parts and packaging (films, plastic bags and foam, etc.) away from babies and children.
- Keep away from sharp or corrosive items to avoid potential product damage or bodily injury.