

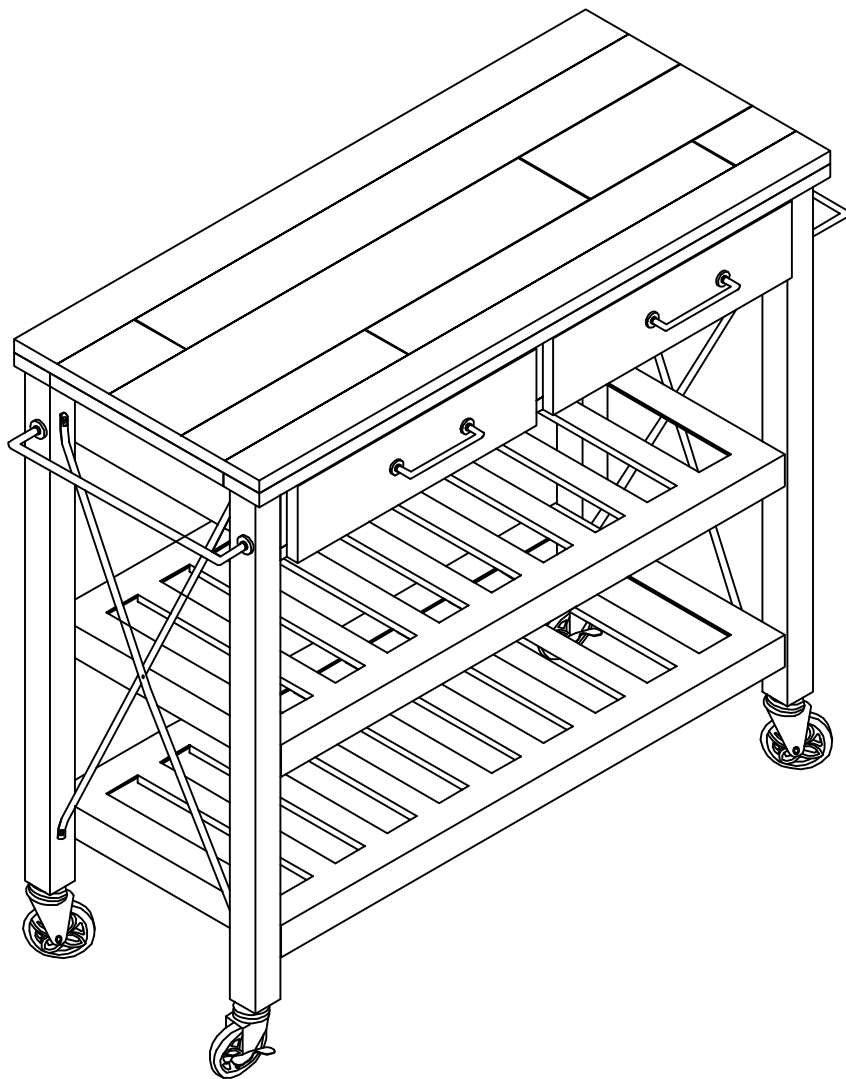

## Rack Kitchen Cart

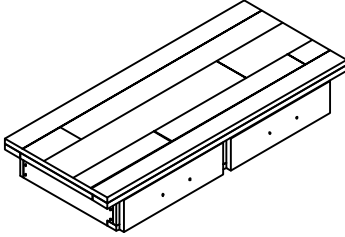

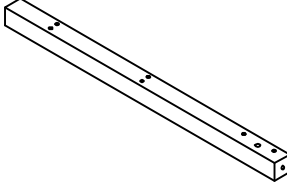

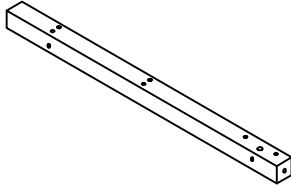
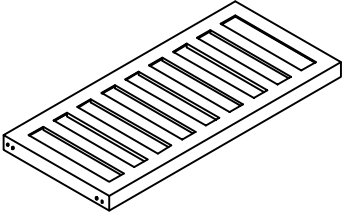
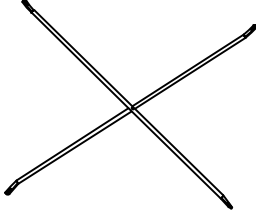
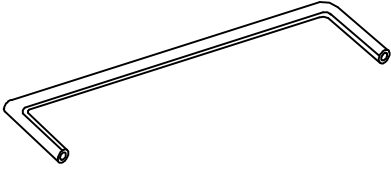

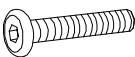
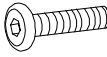

**Care: Use a soft, clean cloth that will not scratch the surface when cleaning. The use of solvents is not necessary. Should you choose to use solvents, test in an inconspicuous area first to avoid damaging the finish. TO clean, simply use a soft, clean cloth lightly dampened with water.**

## PART LIST

 <p>Top</p>		 <p>Left diagonal Leg</p>		 <p>Right diagonal Leg</p>	
<b>A</b>	1pc	<b>B</b>	2pcs	<b>C</b>	2pcs
 <p>Shelf</p>		 <p>Rod(M8mm)</p>		 <p>Towel Bar</p>	
<b>D1/D2</b>	2pcs	<b>E</b>	2pcs	<b>F</b>	2pcs
 <p>Locking Caster</p>		 <p>Caster</p>			
<b>G</b>	2pcs	<b>H</b>	2pcs		

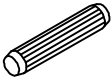
## HARDWARE LIST

 <p>Long Bolt(M6*38mm)</p>		 <p>Short Bolt(M6*28mm)</p>		 <p>Flat Washer(M6mm)</p>	
<b>I</b>	4pcs	<b>J</b>	28pcs	<b>K</b>	16pcs
 <p>Spring Washer(M6mm)</p>		 <p>Drawer handle</p>		 <p>Handle Washer(M6mm)</p>	
<b>L</b>	16pcs	<b>M</b>	2pcs	<b>N</b>	8pcs
 <p>Wood Dowel(M8mm)</p>		 <p>Wrench(M17mm)</p>		 <p>Allen Key(M4mm)</p>	
<b>O</b>	12pcs	<b>P</b>	1pc	<b>Q</b>	1pc

**Step 1.** Attach Towel Bar(F) & Handle Washer(N) to Legs (B&C) using Long Bolts (I) & Allen Key (Q) .  
Repeat this step for the remaining two legs .

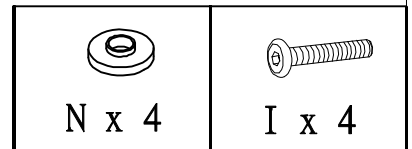
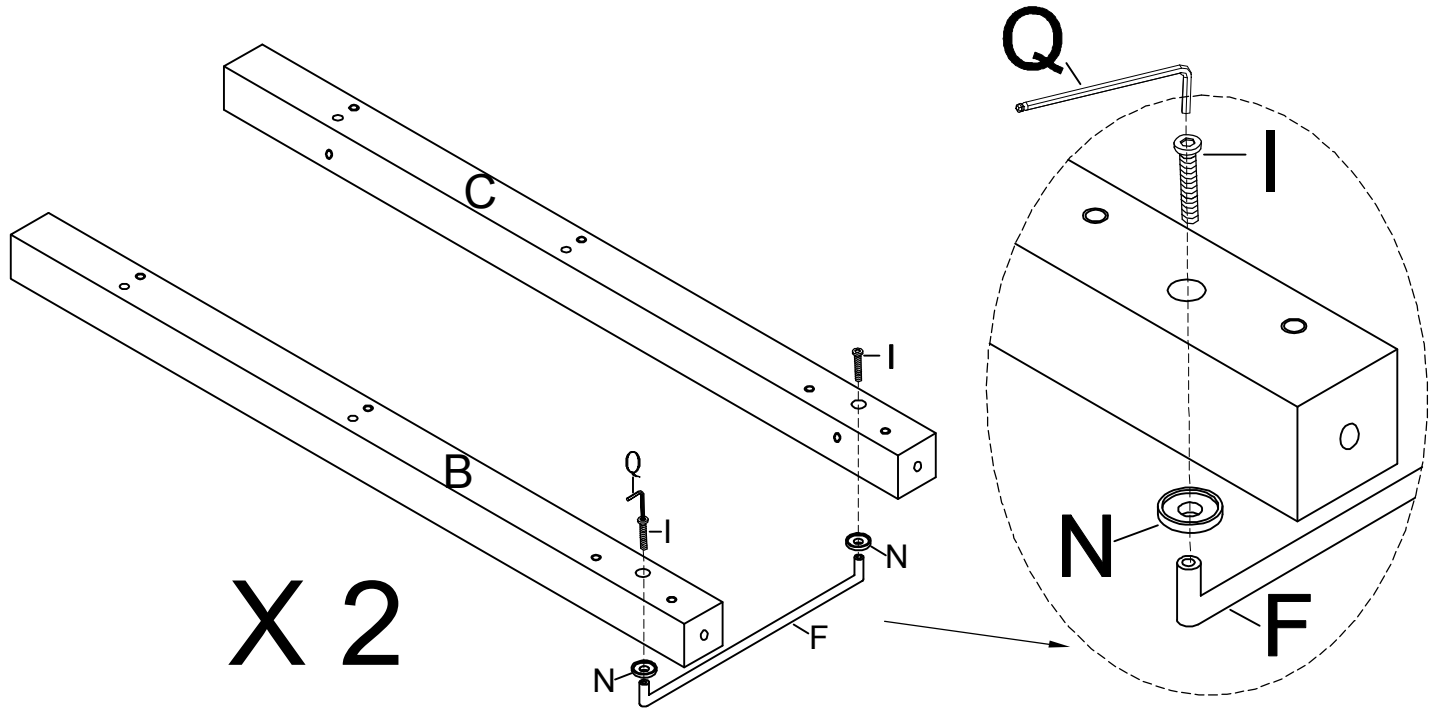

**Step 2.** Place Top (A) face down on flat surface ,press up and down the slide joint , to pull out the drawer .

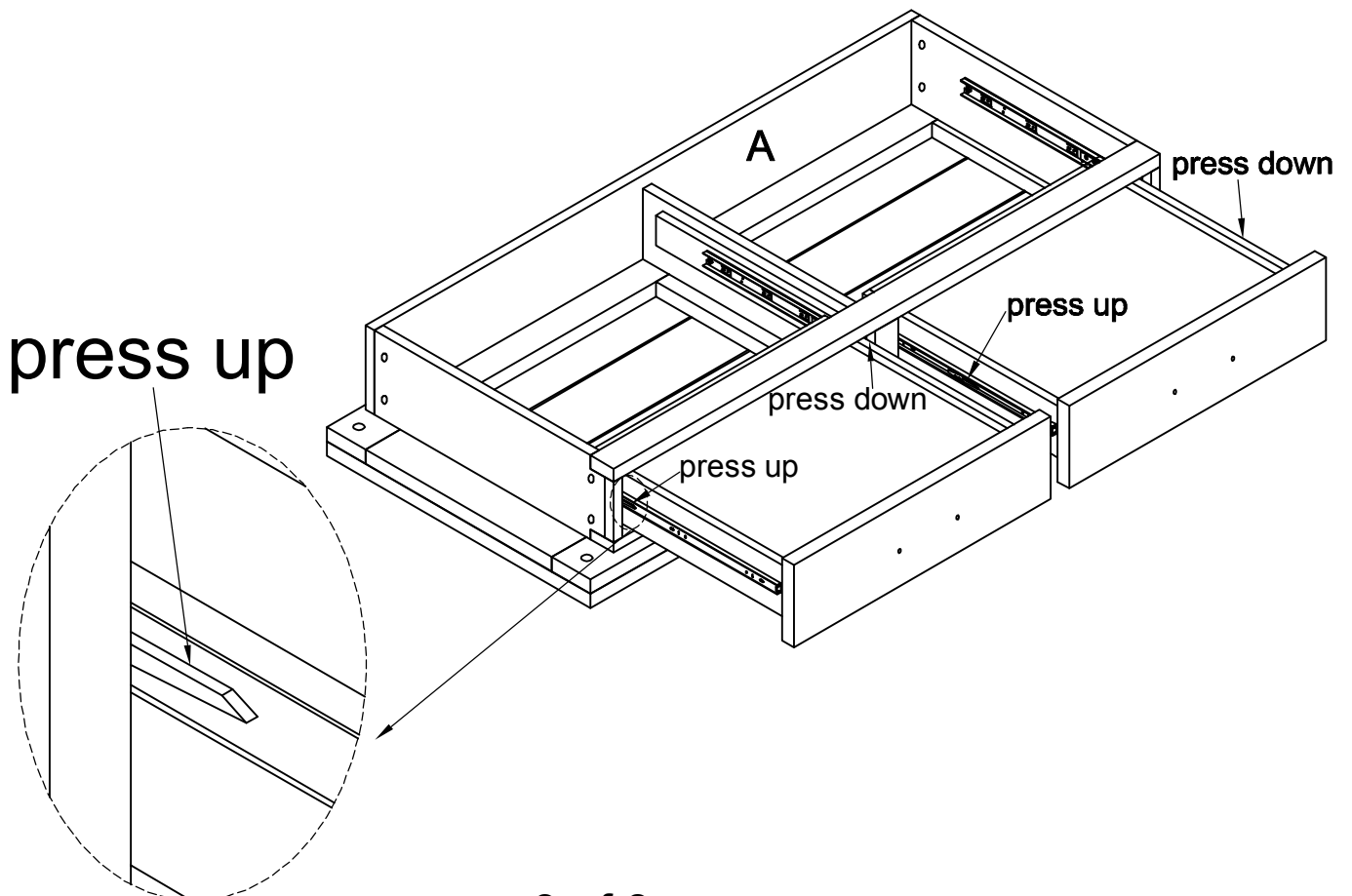

**Step 3.** Set legs (B&C) into place on Top (A) using Wood Dowels (O) .

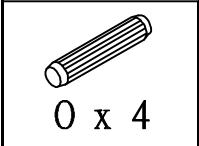
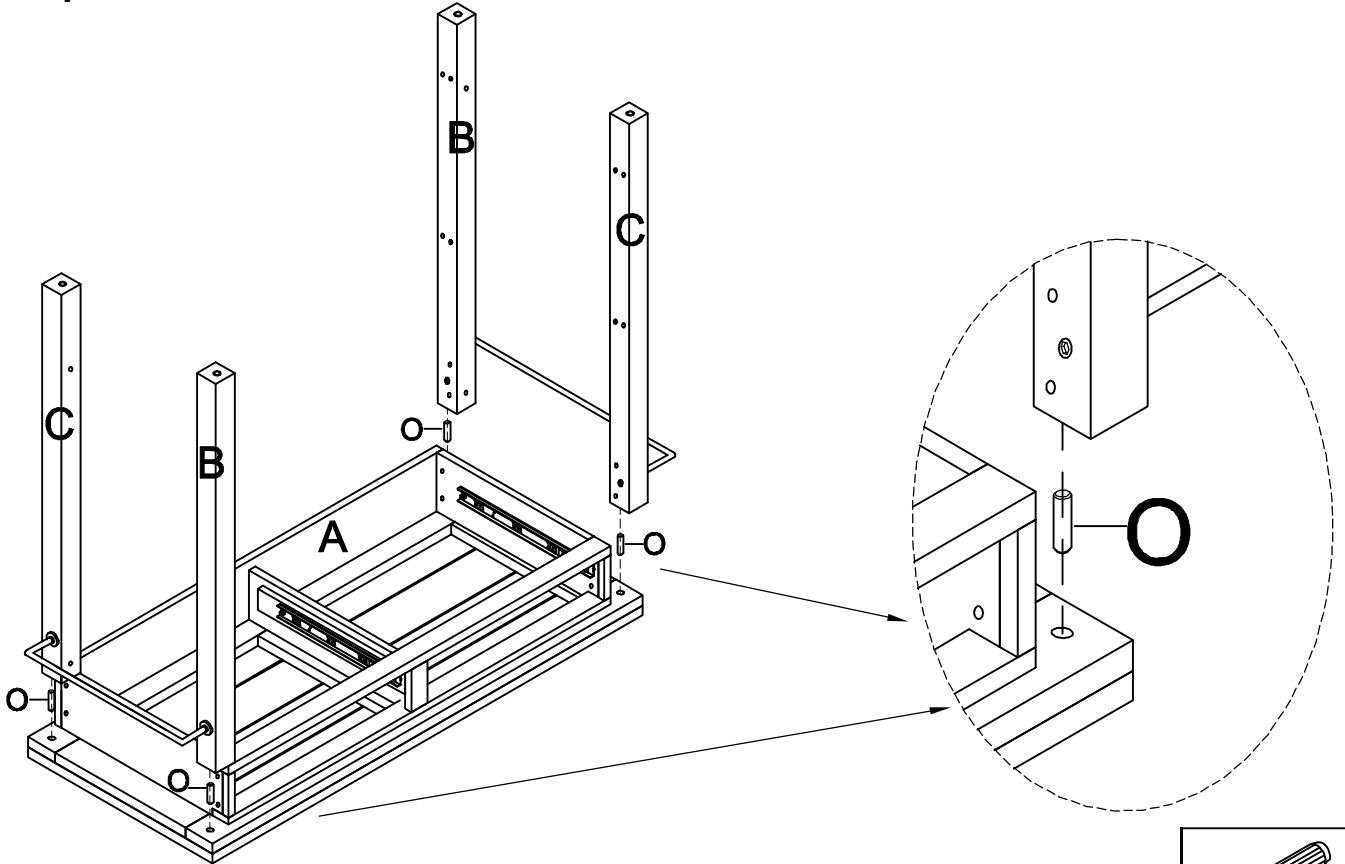

**Step 4.** Attach Legs (B&C) to Top (A) using Flat Washers (K) ,Spring Washers (L) ,Short Bolt (J) and Allen Key (Q).

**NOTE: Do not fully tighten all bolts in this step .**

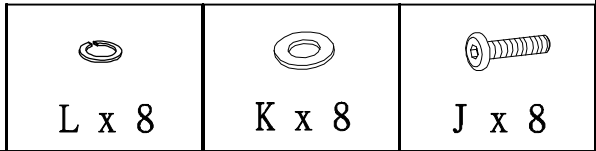
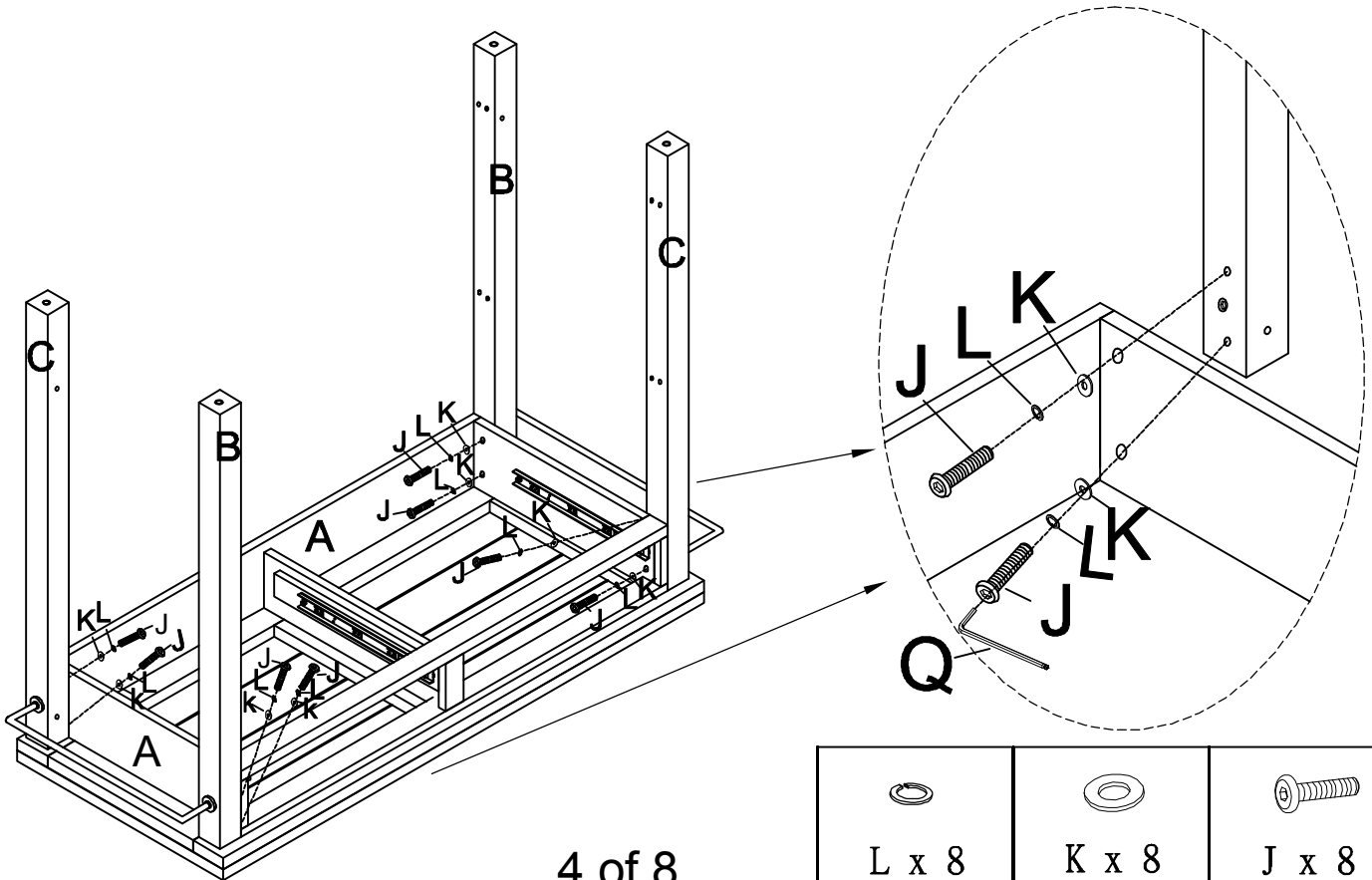

**Step 5.** Align Shelf (D1) with Legs (B&C) as shown below. Insert four wood dowels through the outer holes in the shelf (D1) into the Legs (B&C) to help hold the shelf in place. Install Flat Washers (K), Spring Washers (L) and Short Bolt (J) through the inner holes in the shelf into the Legs (B&C). Tighten with Allen Key (Q).

**NOTE1: Do not fully tighten bolts at this time.**

Repeat this for Shelf (D2) .

**NOTE2: .Once both shelves are in place, fully tighten all bolts.**

**Once tight, remove wood dowels.**

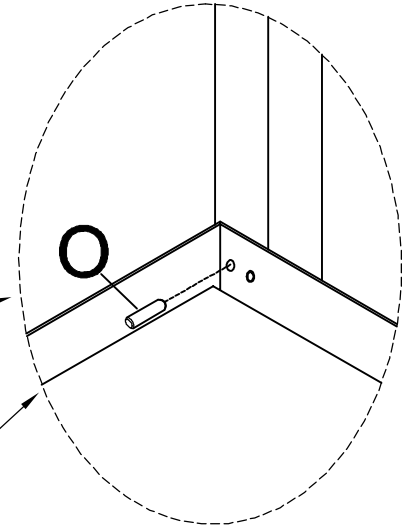
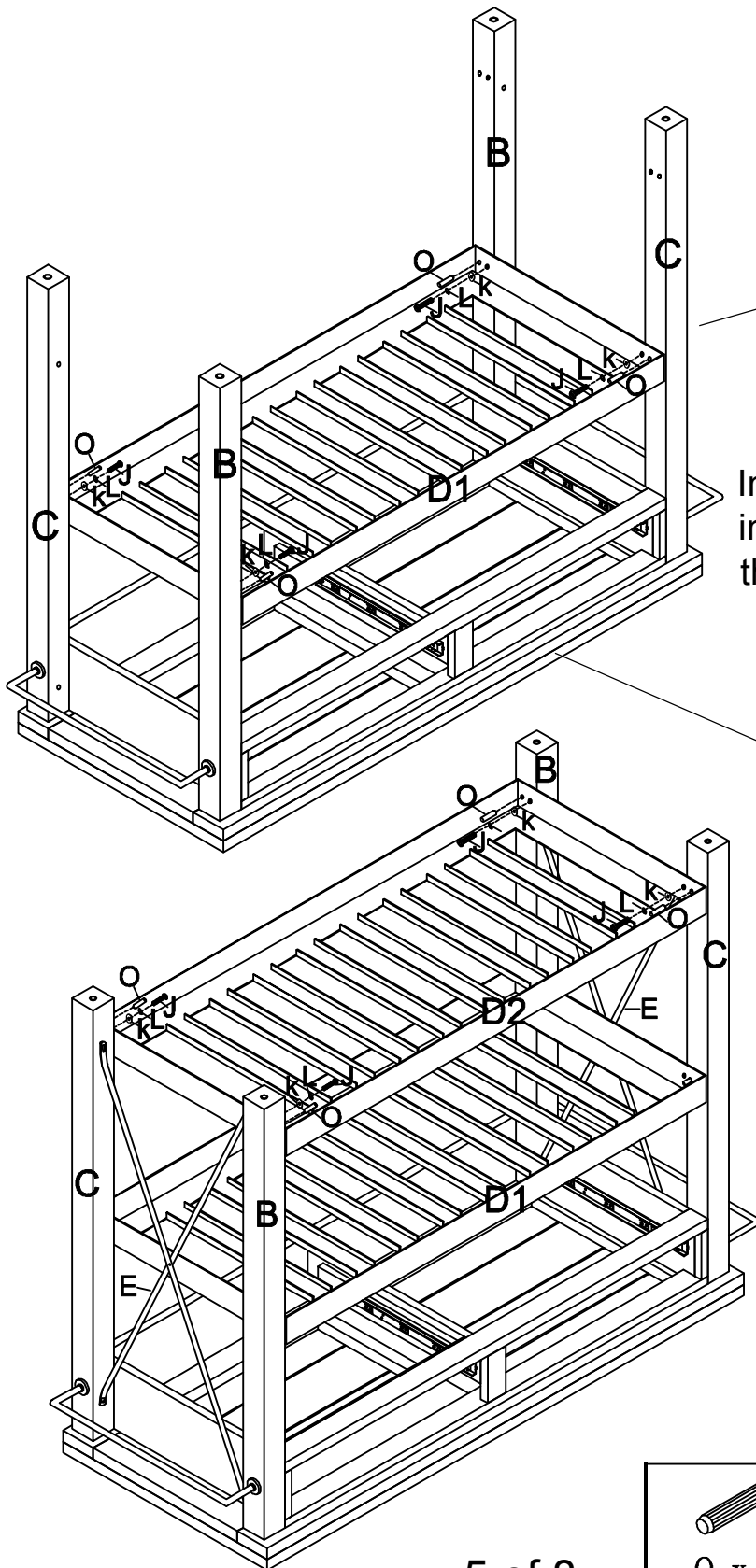

Insert four Wood Dowels (O) into the four legs (B&C) through the shelf first.

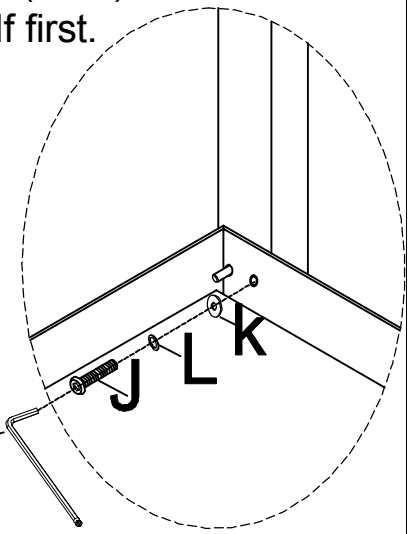

Bolt the shelf into place by using Flat Washers (K), Spring Washers (L), Short Bolt (J) and Allen Key (Q).

O x 8	L x 8	K x 8	J x 8

**Step 6.** Attach Rod (E) to Legs (B&C), using short Bolts (J) and Allen Key (Q) .

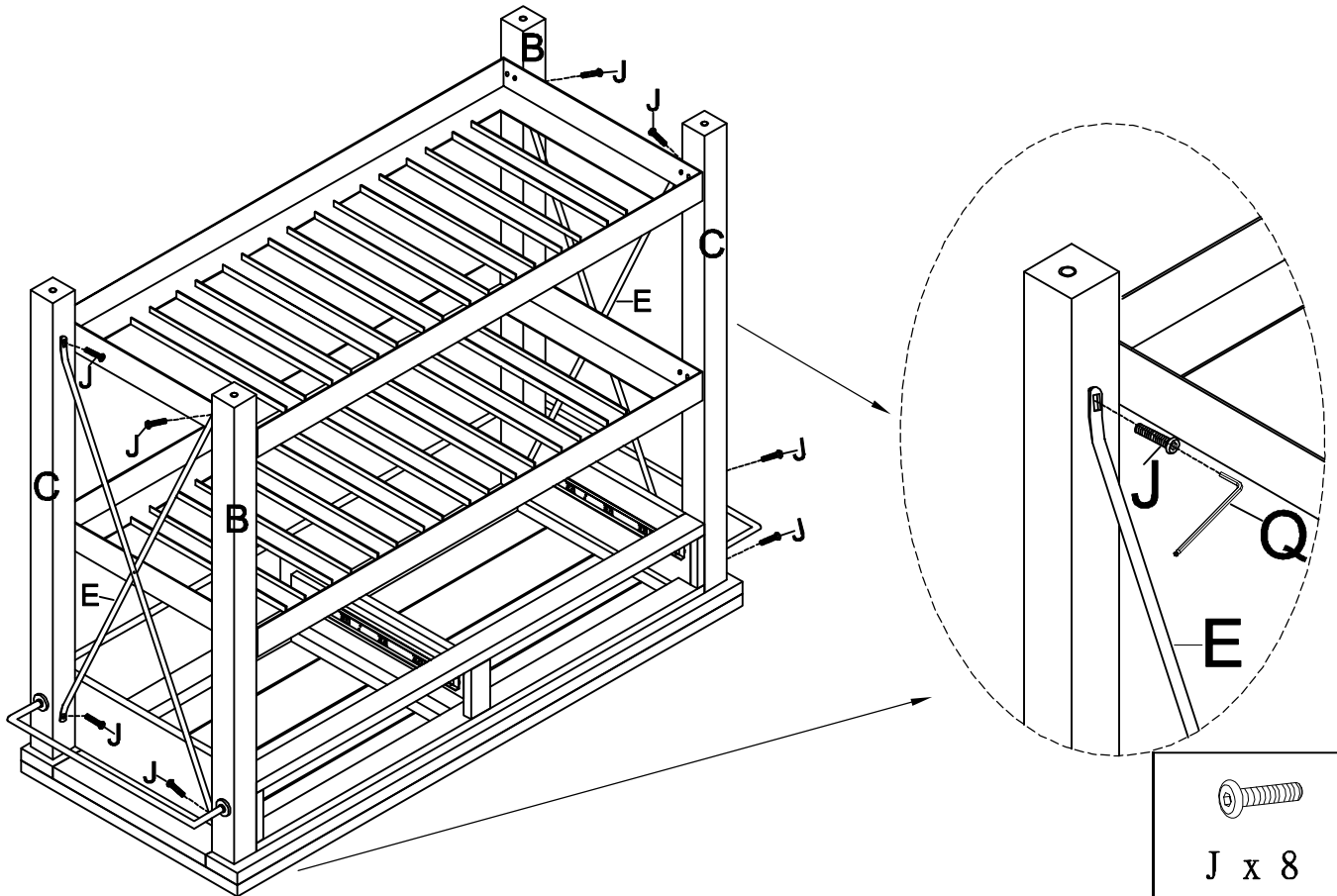

**Step 7.** Attach Locking Casters (G)&Casters (H) using wrench (P) .  
Carefully turn cabinet right side up ,with casters on the floor.

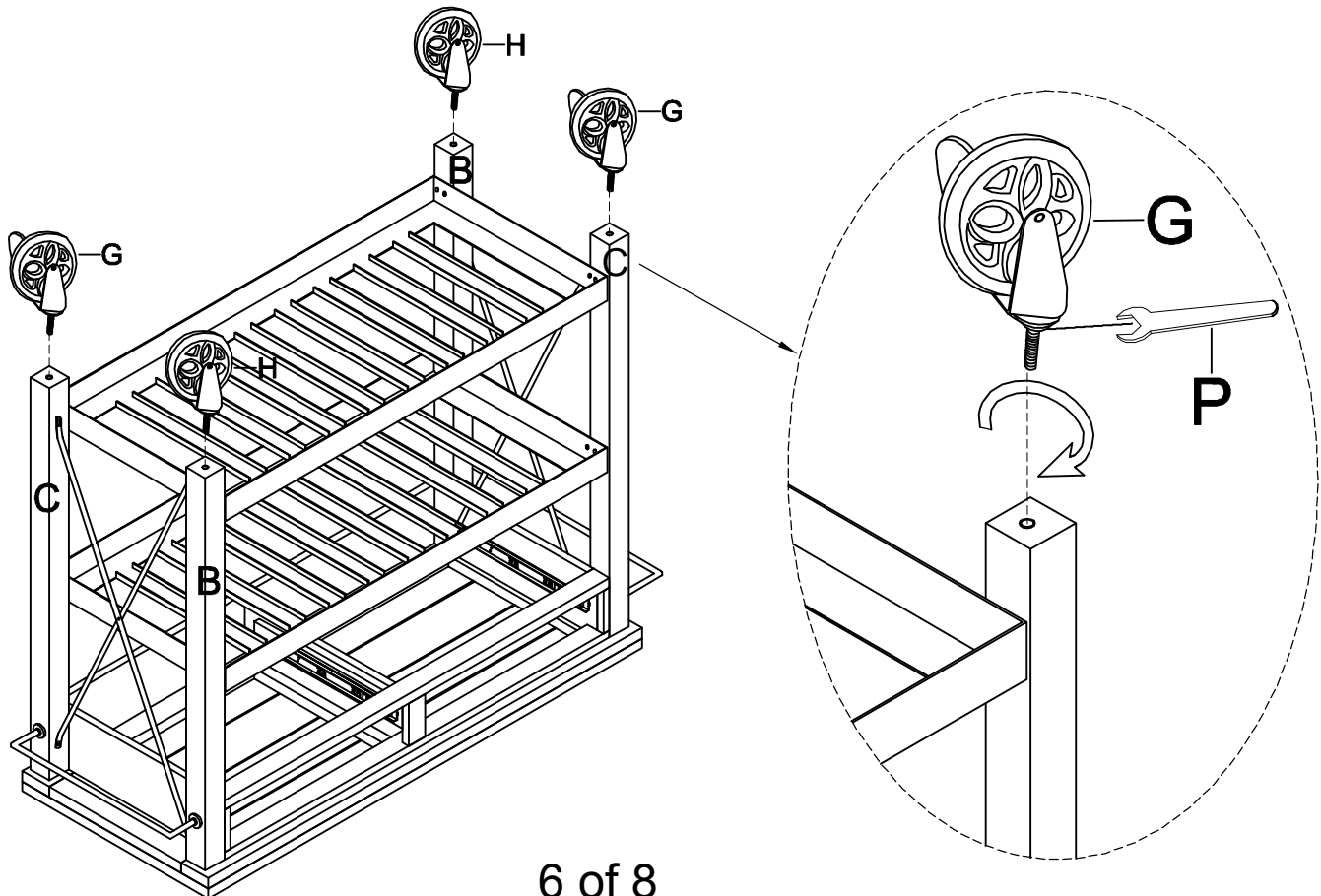

**Step 8.** Attach Drawer Handle Washers (N) and Drawer Handles (M) to drawers using Short Bolts(J) and Allen Key (Q) .

Left drawer has a brand in it .

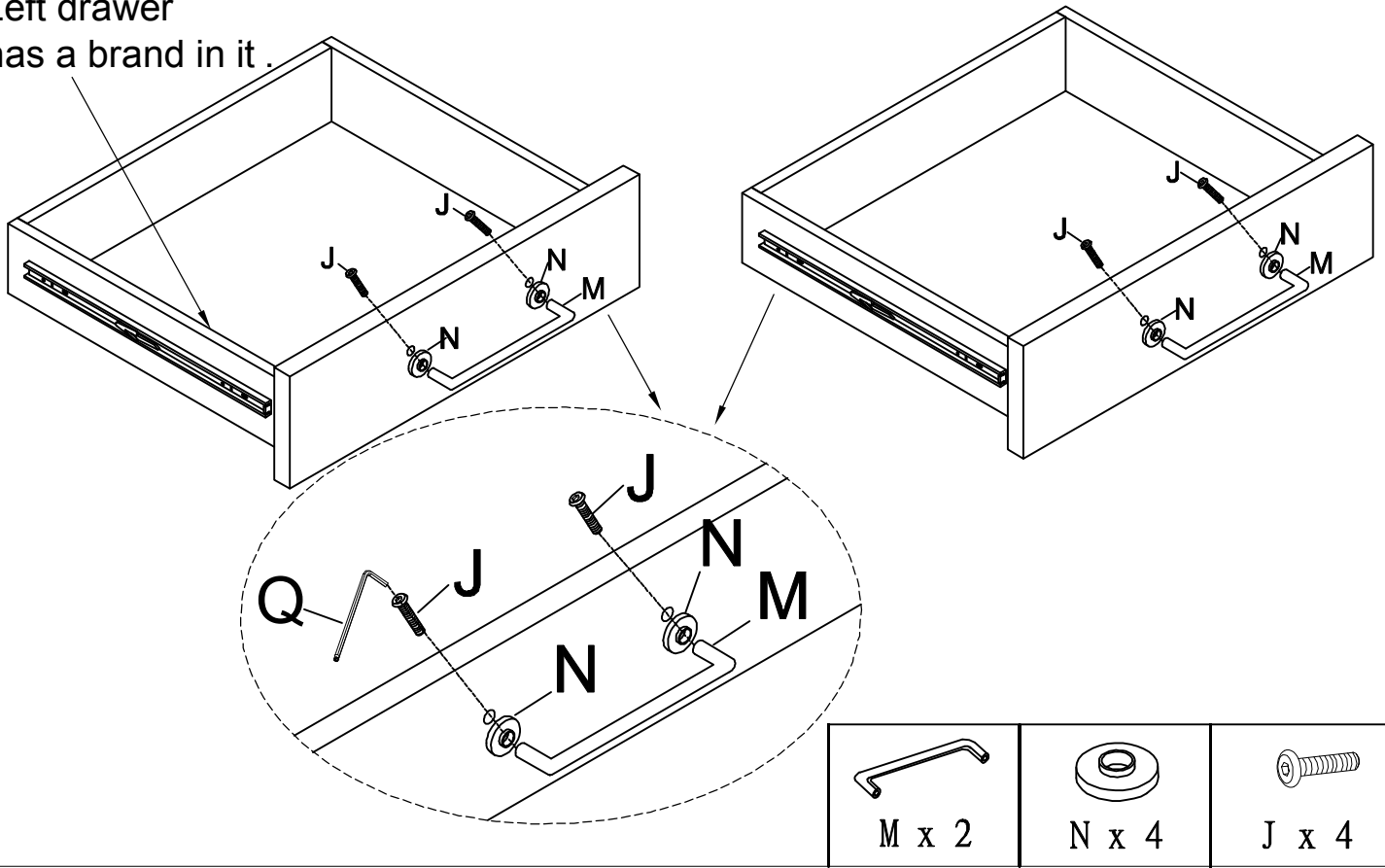

**Step 9.** Insert drawers into cabinet .

