

HONGMAO

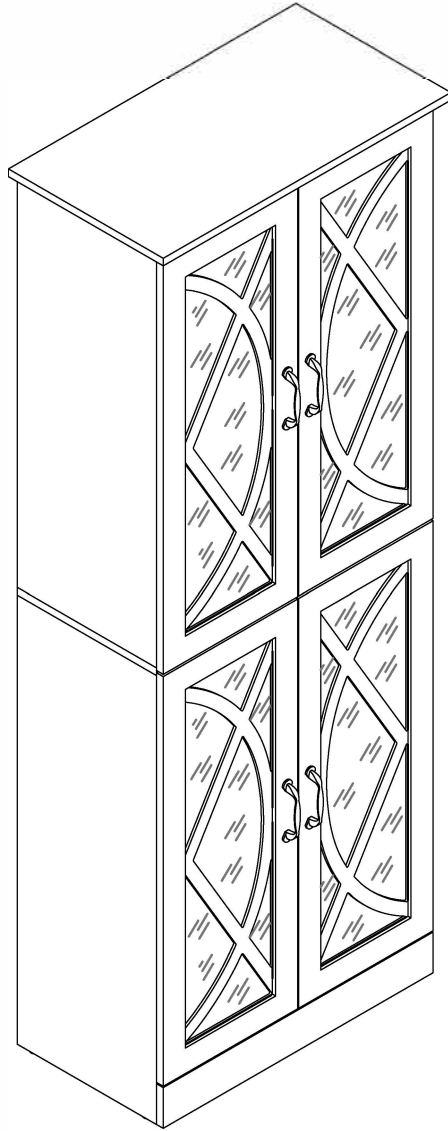

ITEM NO.HMGG0001

NOTE:

This brochure contains IMPORTANT safty info. Please read and keep for future reference.

MAINTAINANCE AND WARNING

- 1.Keep furniture away from heat sources.
- 2.Do not clean furniture with harsh cleaner or polishes.Do not use detergents,solvents,abrasives,spray packs or leather cleaner. Use non-color mild soa with warm water to clean spills(Mix 1:10 soap to water).
- 3.Do not place furniture under direct sunlight,material will possibly fade over time.
- 4.Do not use on site dry cleaning machine.Children should not climb or jump on the furniture.
- 5.Do not write on furniture that is not protectedby a padded barrier.
- 6.Not for commercial use,only for residential use.



Weight Limitation
110 LBS

EXPLOSIVE VIEW

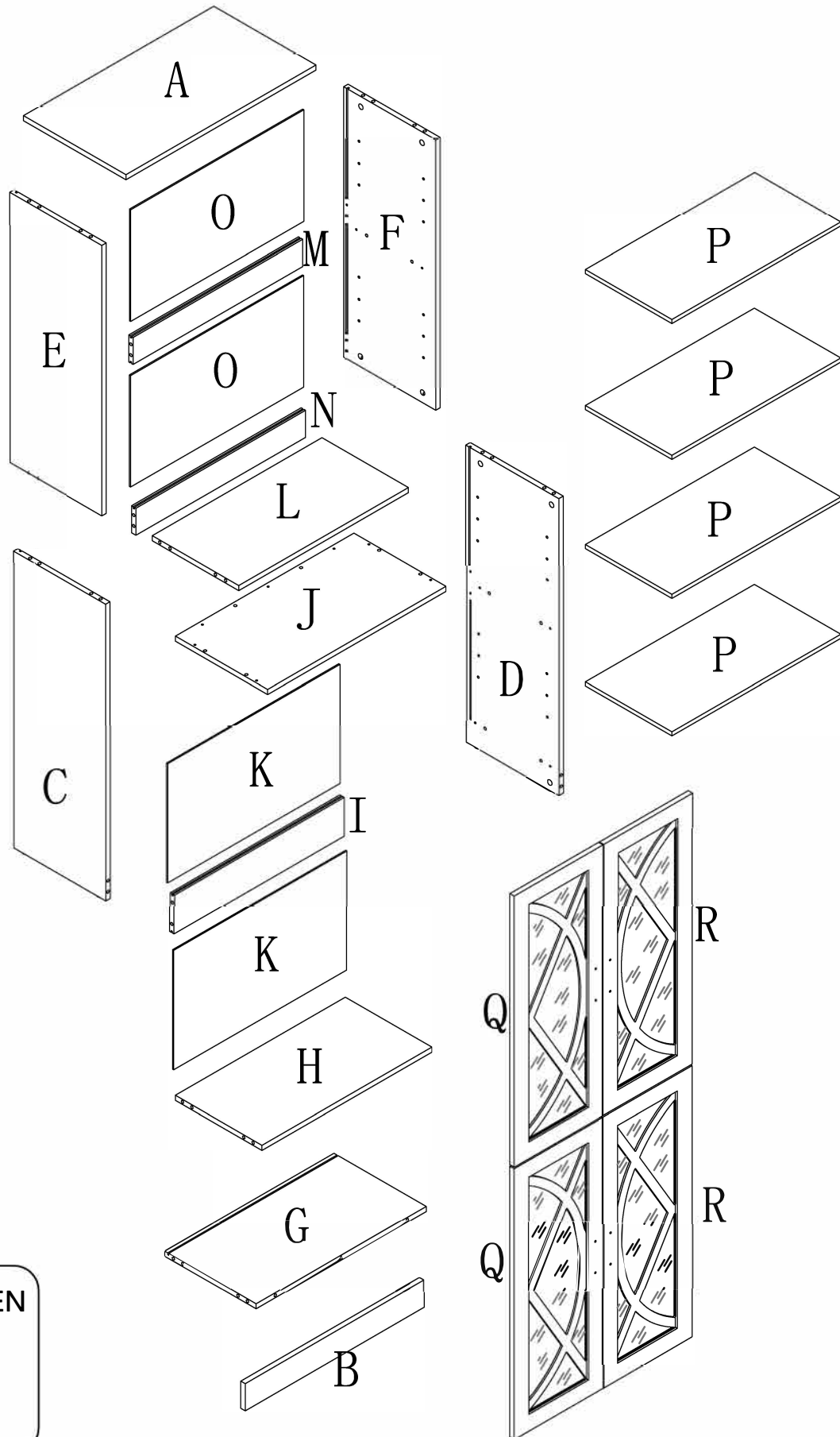



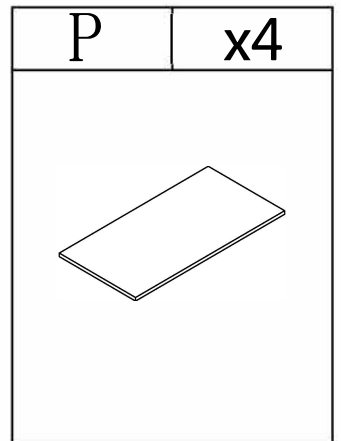
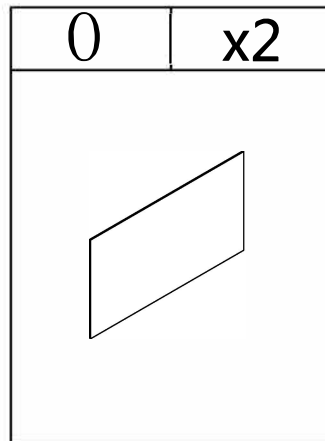
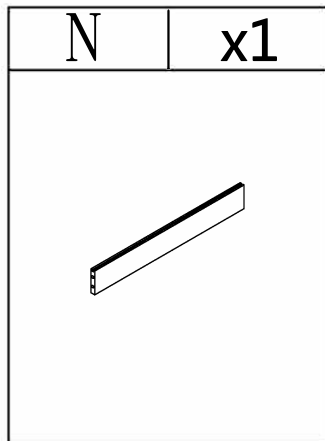
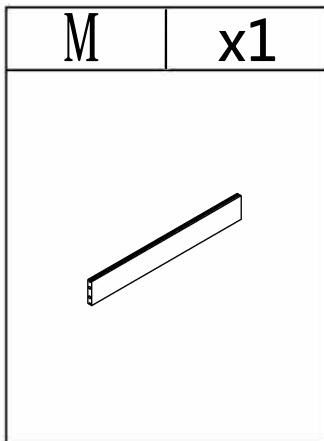
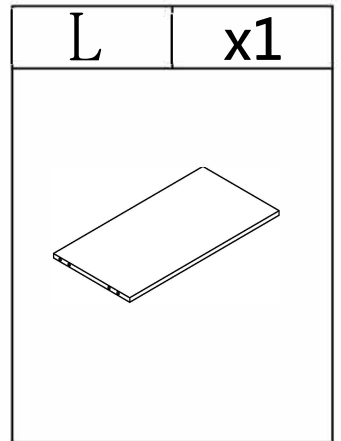
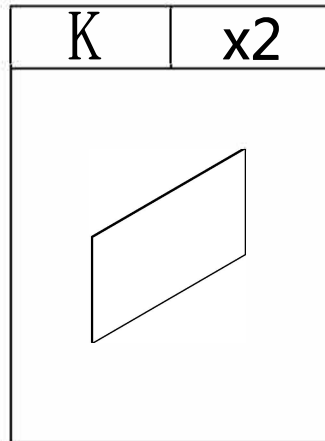
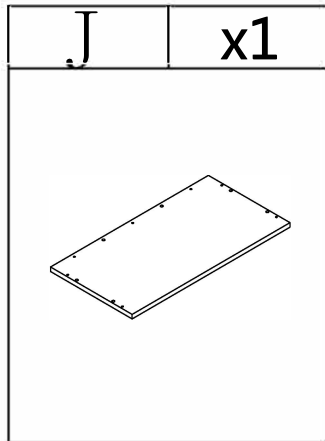
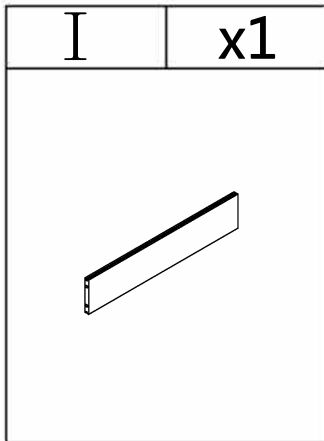
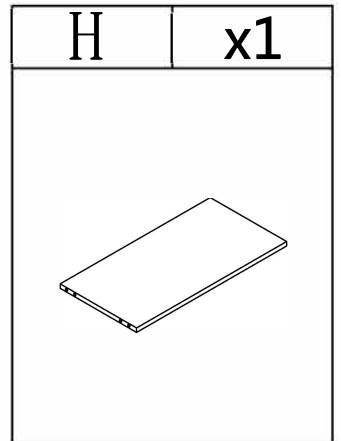
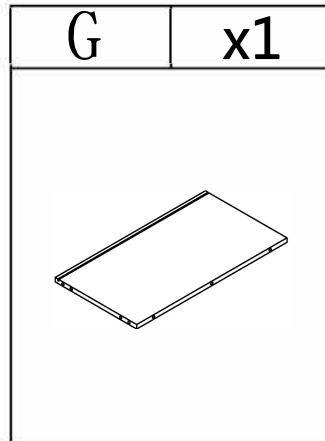
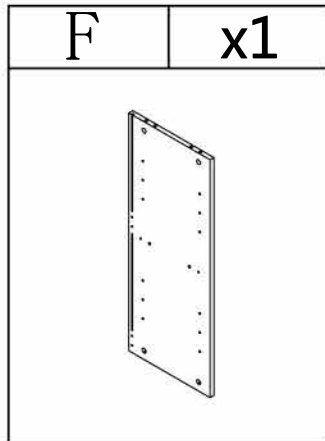
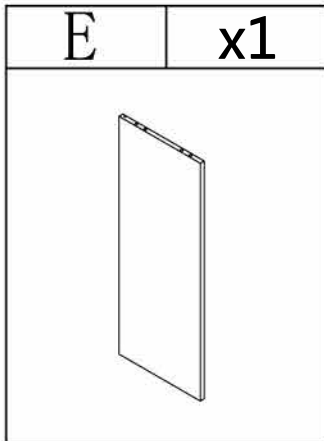
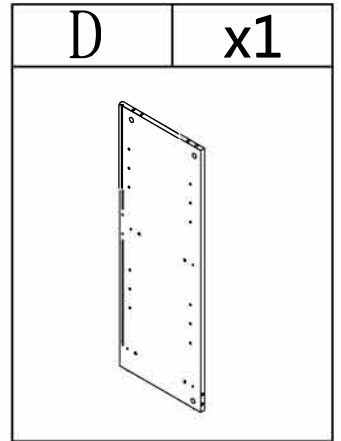
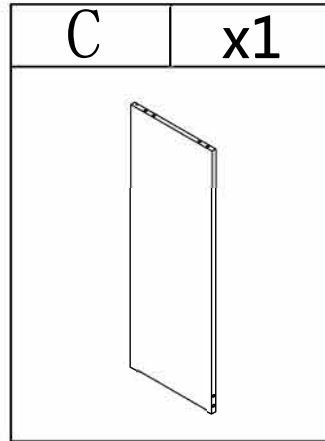
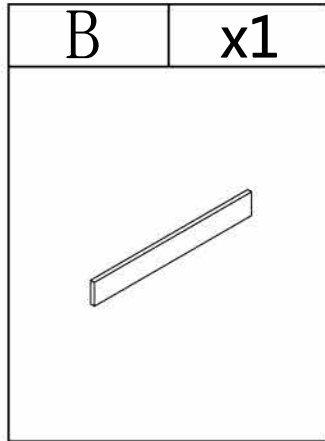
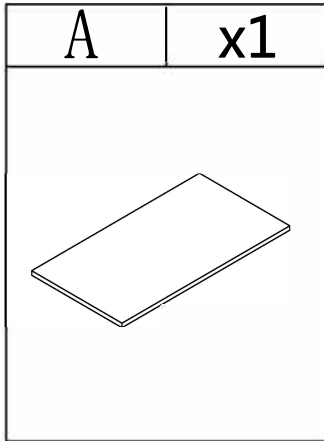



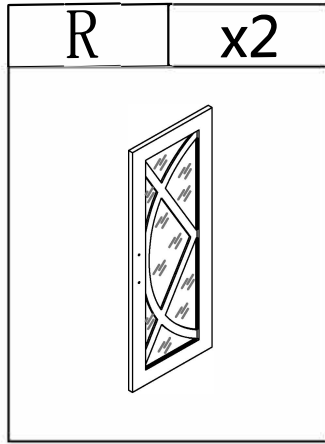
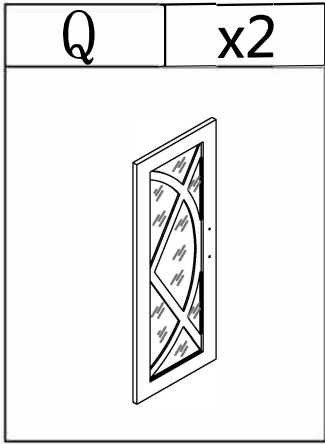



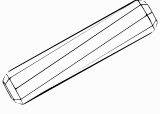
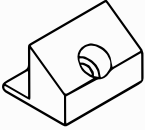
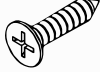
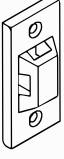

PARTS LIST

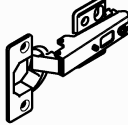





PARTS LIST

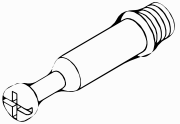

HARDWARE LIST

#1	x43		
#2	x43		
#3	x30		ø8*30mm
#4	x24		
#5	x28		ø3*16mm*6#
#6	x4		
#7	x16		
#8	x8		
#9	x48		ø3.5*14mm*7#
#10	x4		
#11	x8		ø4*19mm
#12	x4		
#13	x4		ø3.5*35mm*7#
#14	x2		
#15	x1		

HARDWARE SPARE LIST

#1	x2		
#2	x2		
#3	x2		ø8*30mm
#9	x2		ø3.5*14mm*7#

ASSEMBLY INSTRUCTIONS

STEP-1

1. Make sure all holes aligned and use bolt (#1) to attach them, tighten screw (#15) with screwdriver (#15)

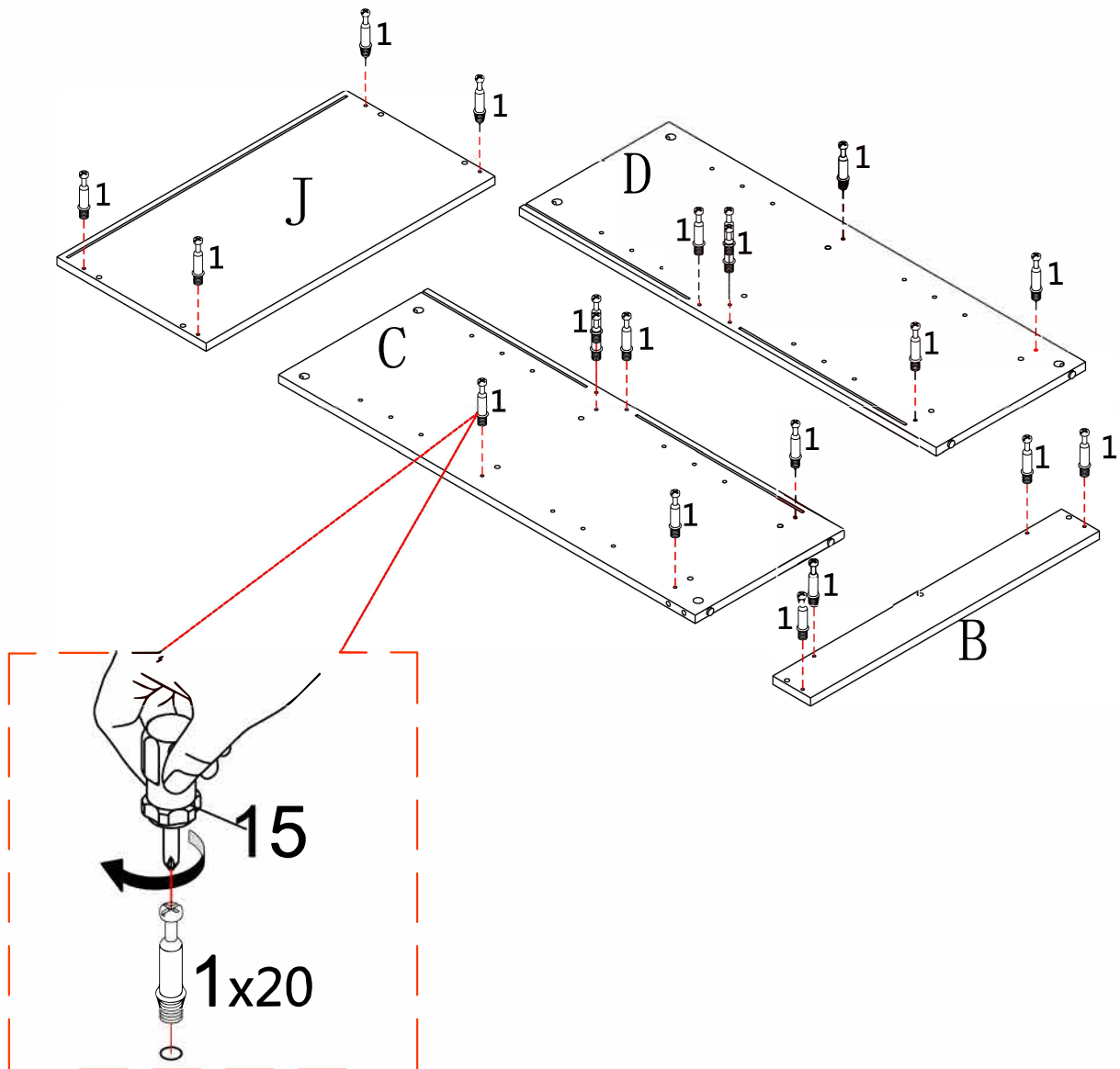

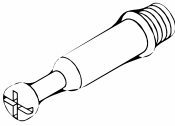
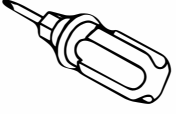
#1	x20	#15	x1
			

ASSEMBLY INSTRUCTIONS

STEP-2

1. Insert panel (I) into side panel (C), make sure all holes aligned and then use connector cam (#2) to attach them, tighten them with screwdriver (#15)

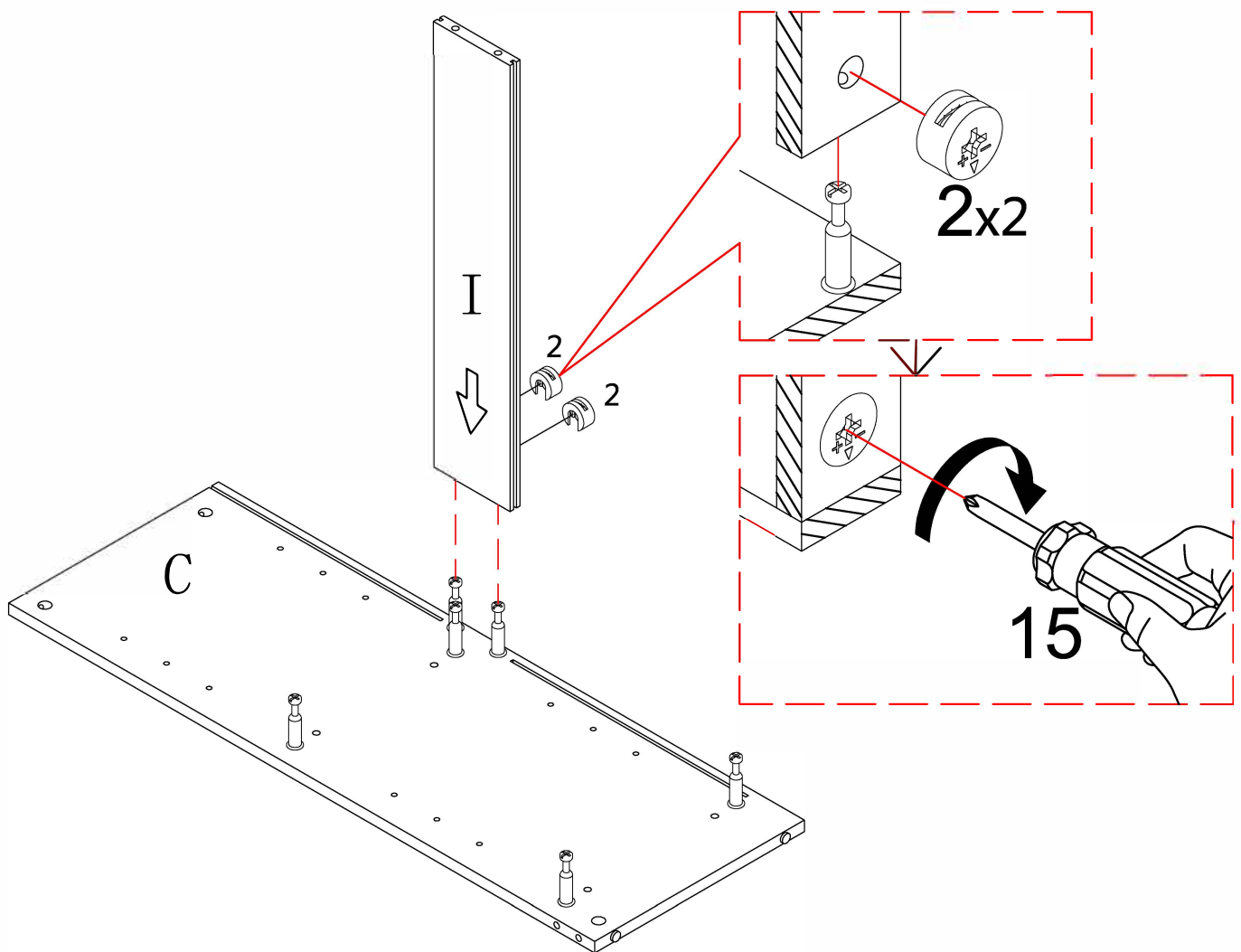

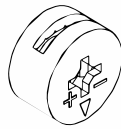
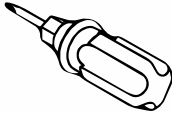
#2	x2	#15	x1
			

ASSEMBLY INSTRUCTIONS

STEP-3

1. Insert 2x dowels (#3) into the designated holes at the bottom edge of
Insert 2x dowels (#3) into the bottom of each panel (G & H).
2. Align panels (G) and (H) vertically onto bottom panel (C), fitting
dowels into the holes. Insert and tighten 2x connector screws (#2) per
panel using screwdriver (#15).

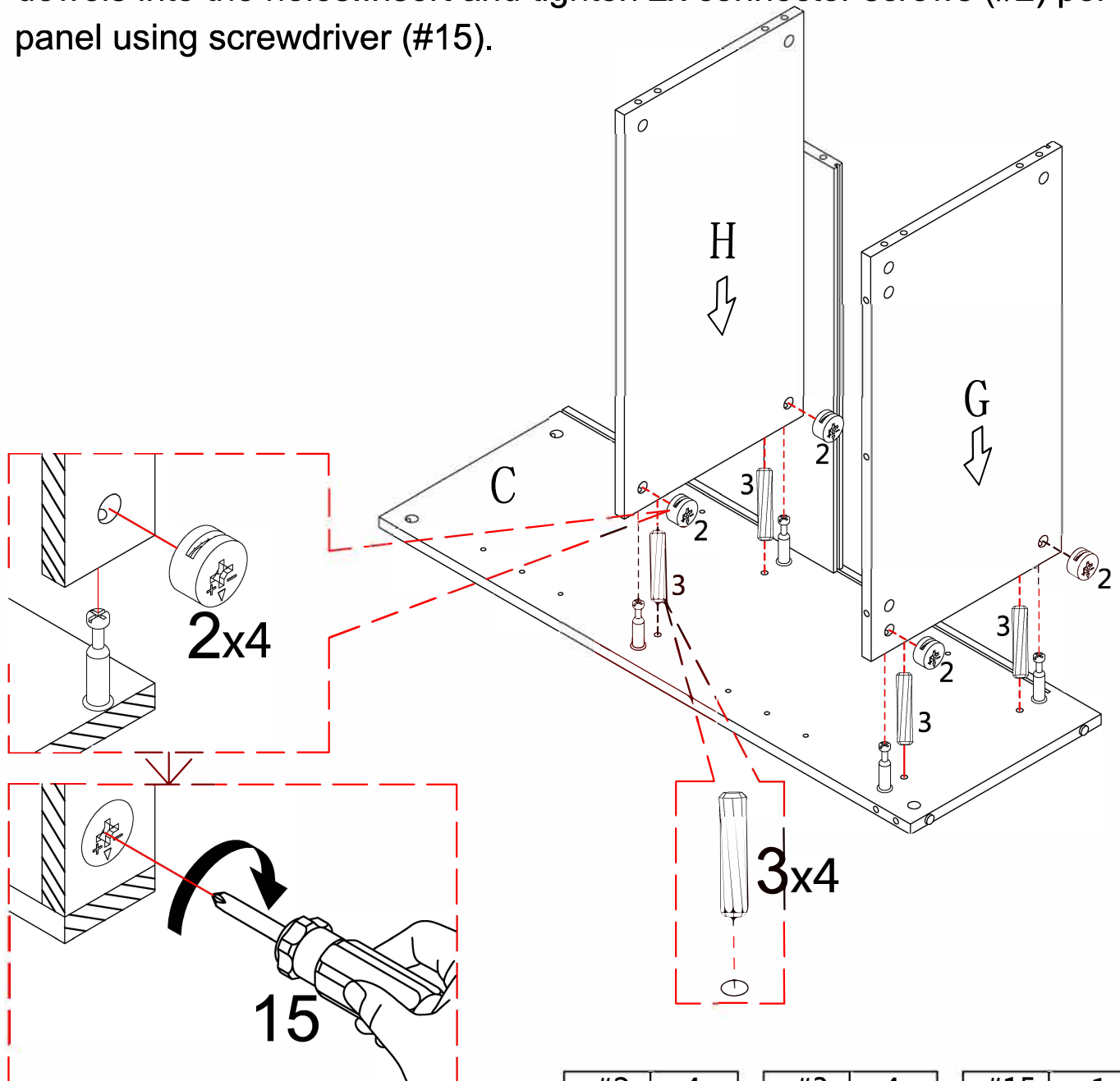

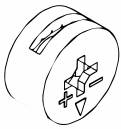
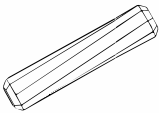
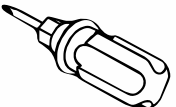
#2	x4	#3	x4	#15	x1
					
		ø8*30mm			

ASSEMBLY INSTRUCTIONS

STEP-4

1. Hold Panel (K) upright above the space between Panels (G) and (H). Slide Panel (K) downward into the groove between Panels (G) and (H). Make sure it fits snugly into the track and sits flush with the bottom panel (C).

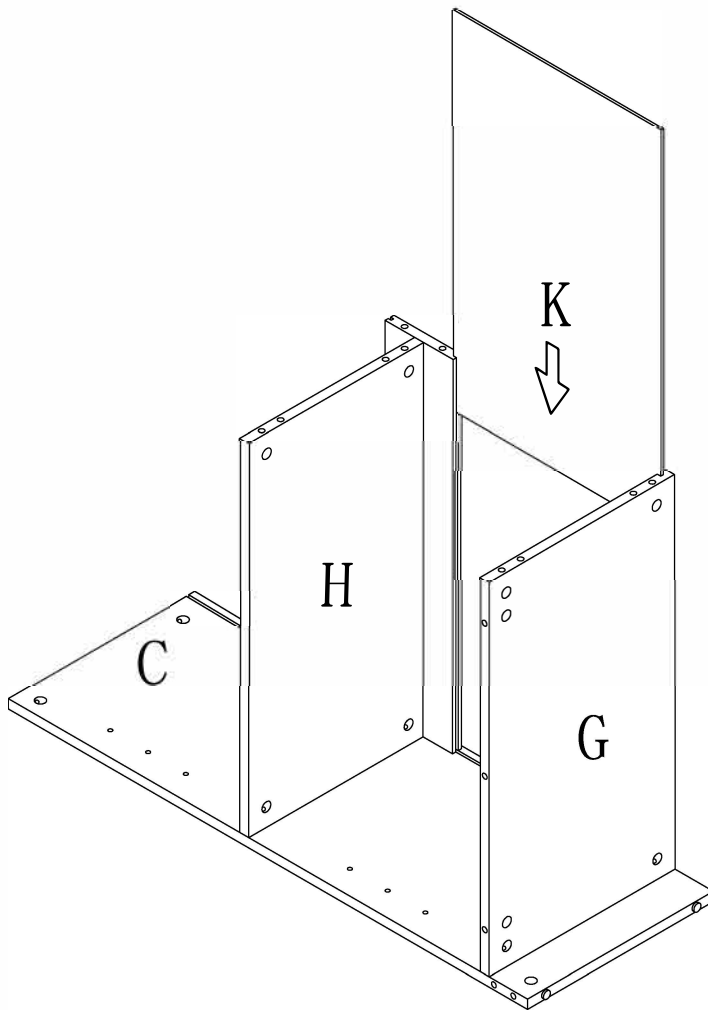

ASSEMBLY INSTRUCTIONS

STEP-5

1. Insert 4 dowels (#3) into the top of Panels (G) and (H). Align Panel (D) on top, making sure dowels and holes line up.
2. Insert 6x connector cam (#2) into the cams and tighten using screwdriver #15.

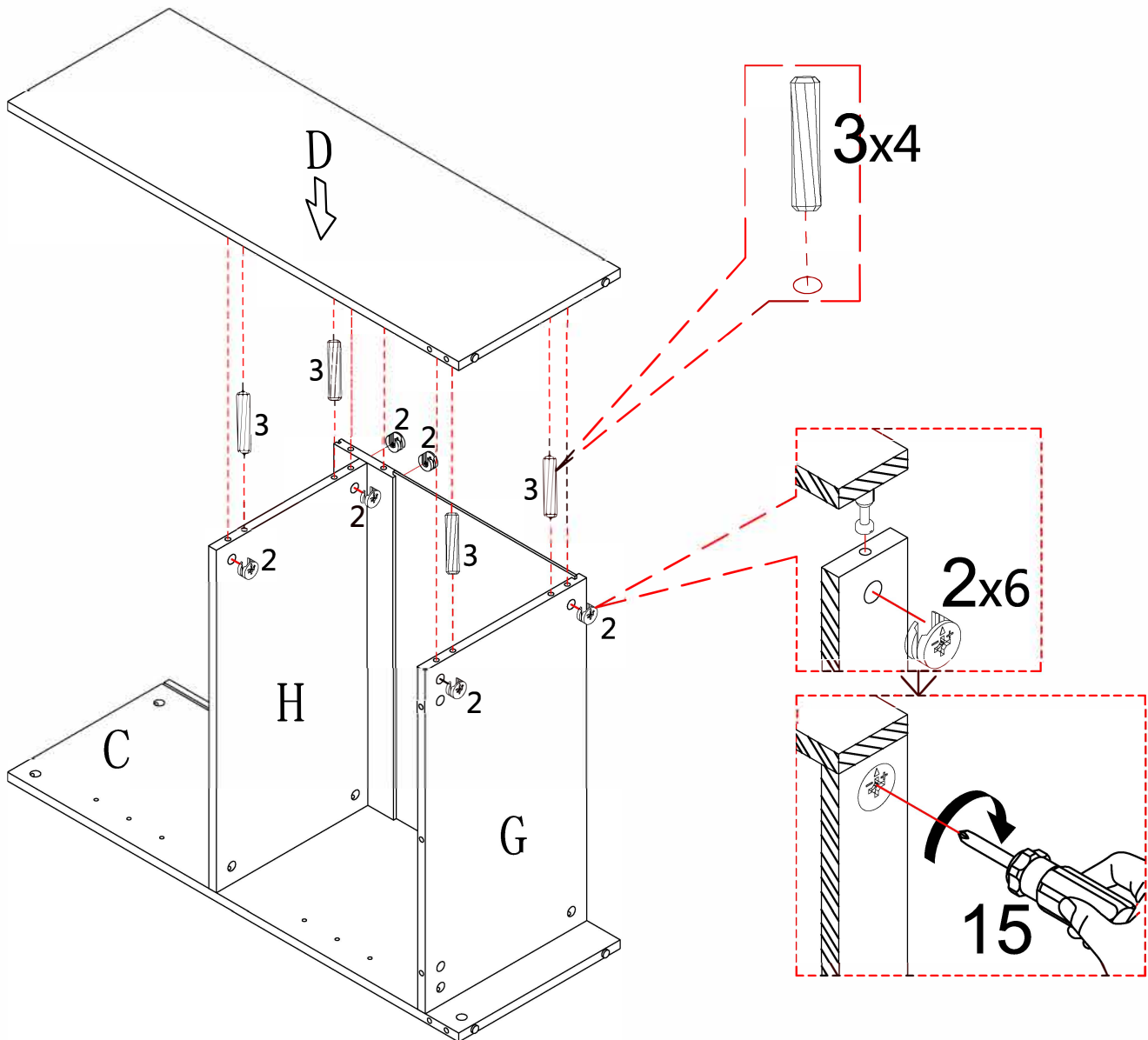

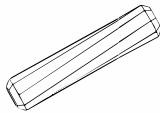
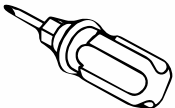

#2	x6	#3	x4	#15	x1
					
		ø8*30mm			

ASSEMBLY INSTRUCTIONS

STEP-6

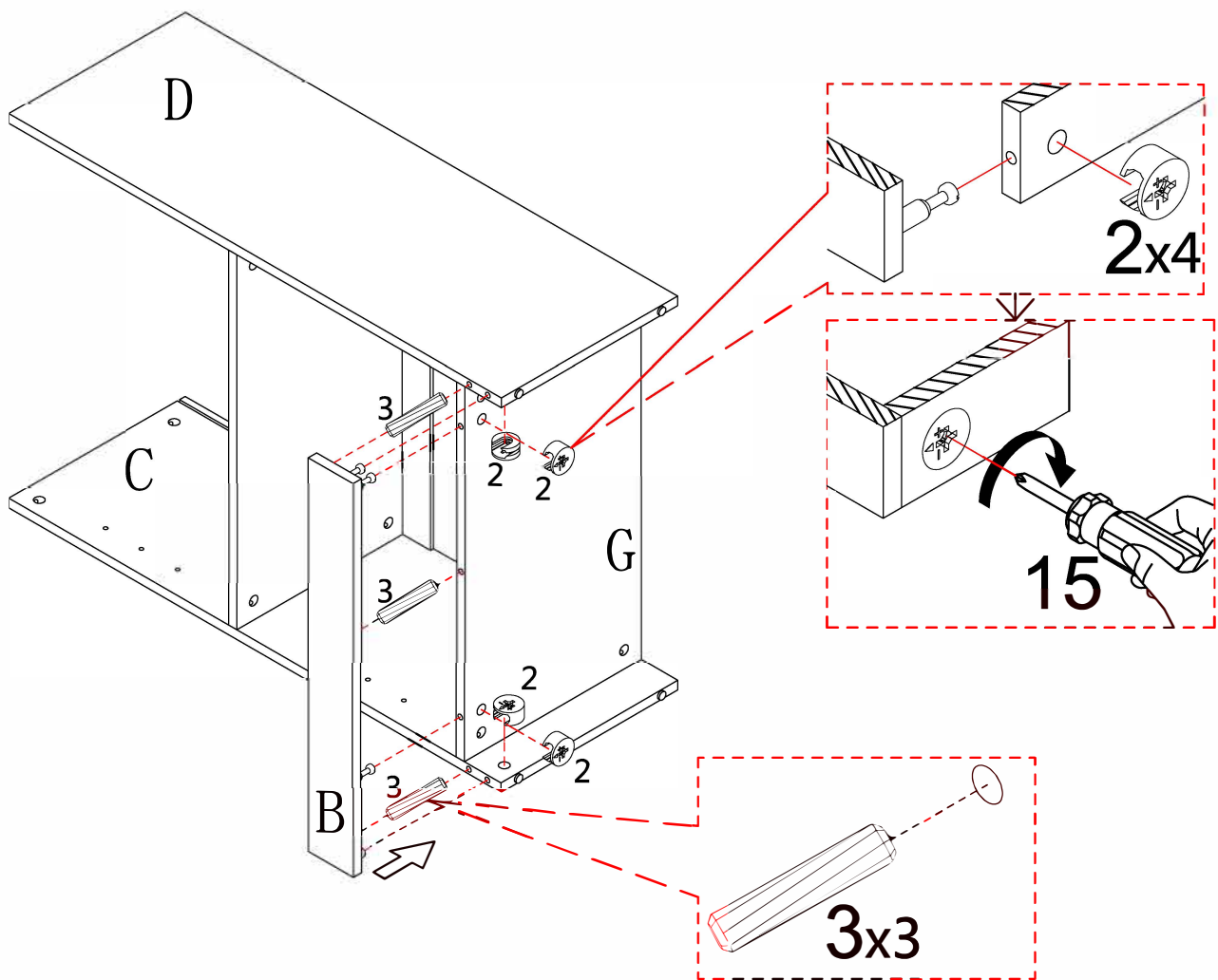
1.insert back panel(G) into the groove of preassembled step 5 ,make sure all holes aligned and use cam (#2) to attach them , tighten them with screwdriver (#15).

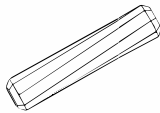
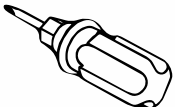

#2	x4	#3	x3	#15	x1
					
		ø8*30mm			

ASSEMBLY INSTRUCTIONS

STEP-7

1. Slide Panel (K) down into the groove behind the middle shelf. Make sure it fits snugly between Panels (C) and (D), and sits flush in the back.

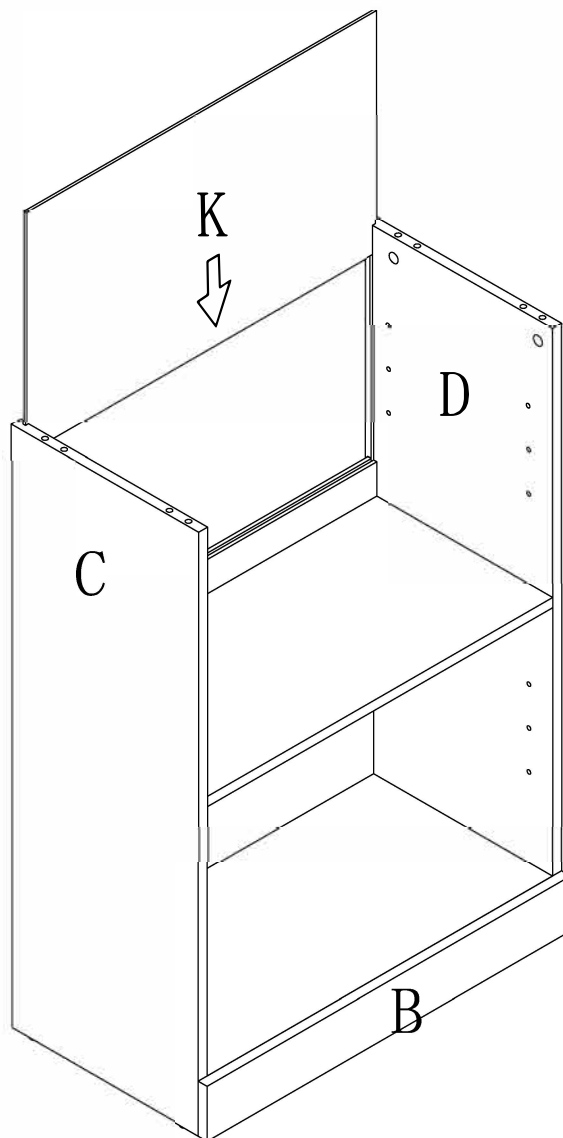

ASSEMBLY INSTRUCTIONS

STEP-8

1. Insert 4x dowels (#3) into the pre-drilled holes on the bottom edges of side panels (J) and (D).
2. Insert 4 connector cam (#2) into the pre-installed cams in panels (C) and (D), and tighten them.
3. Insert panel (J) into the slots on panels (D) and (C).

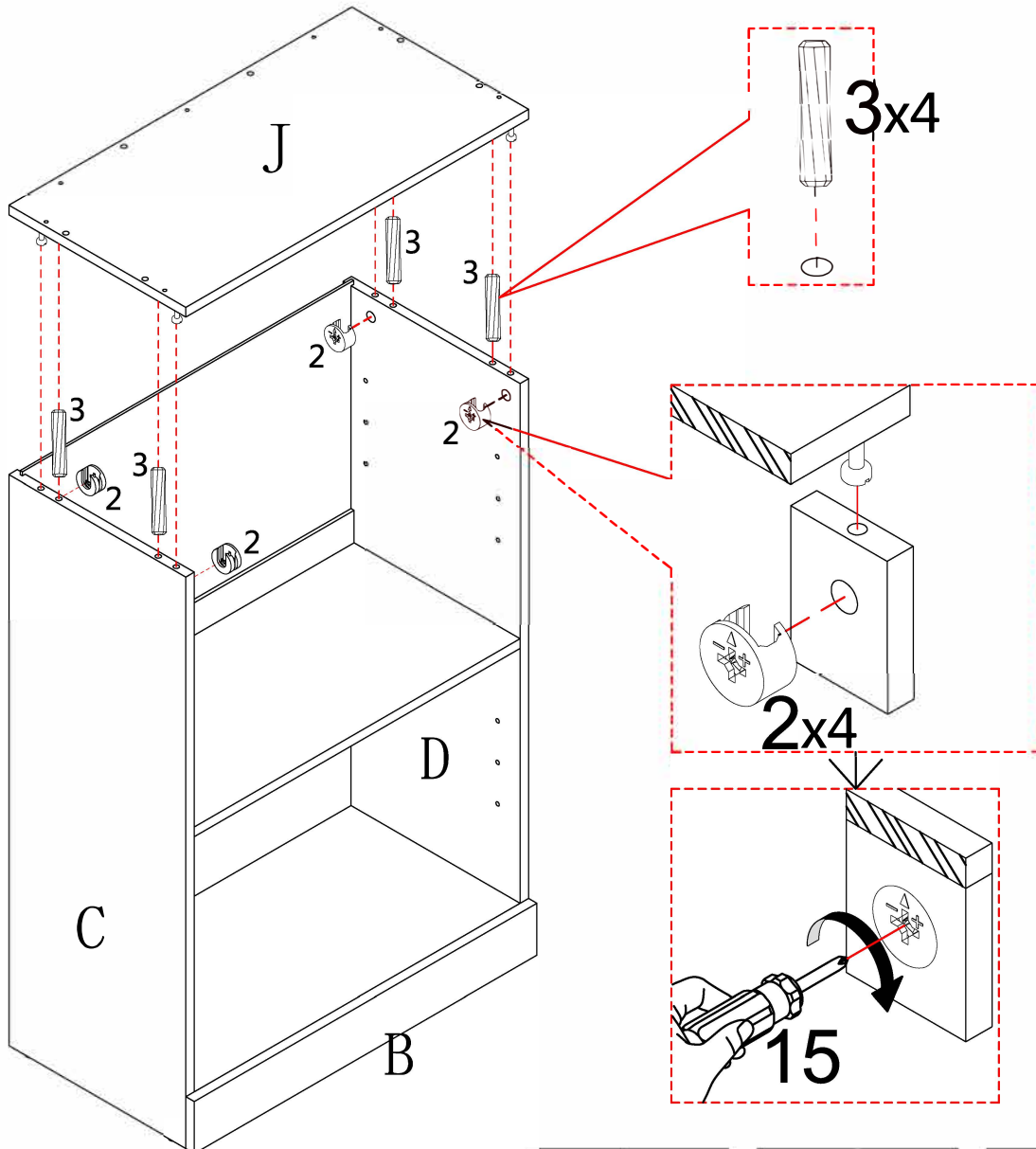

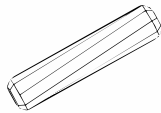
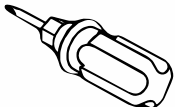

#2	x4	#3	x4	#15	x1
					
		ø8*30mm			

ASSEMBLY INSTRUCTIONS

STEP-9

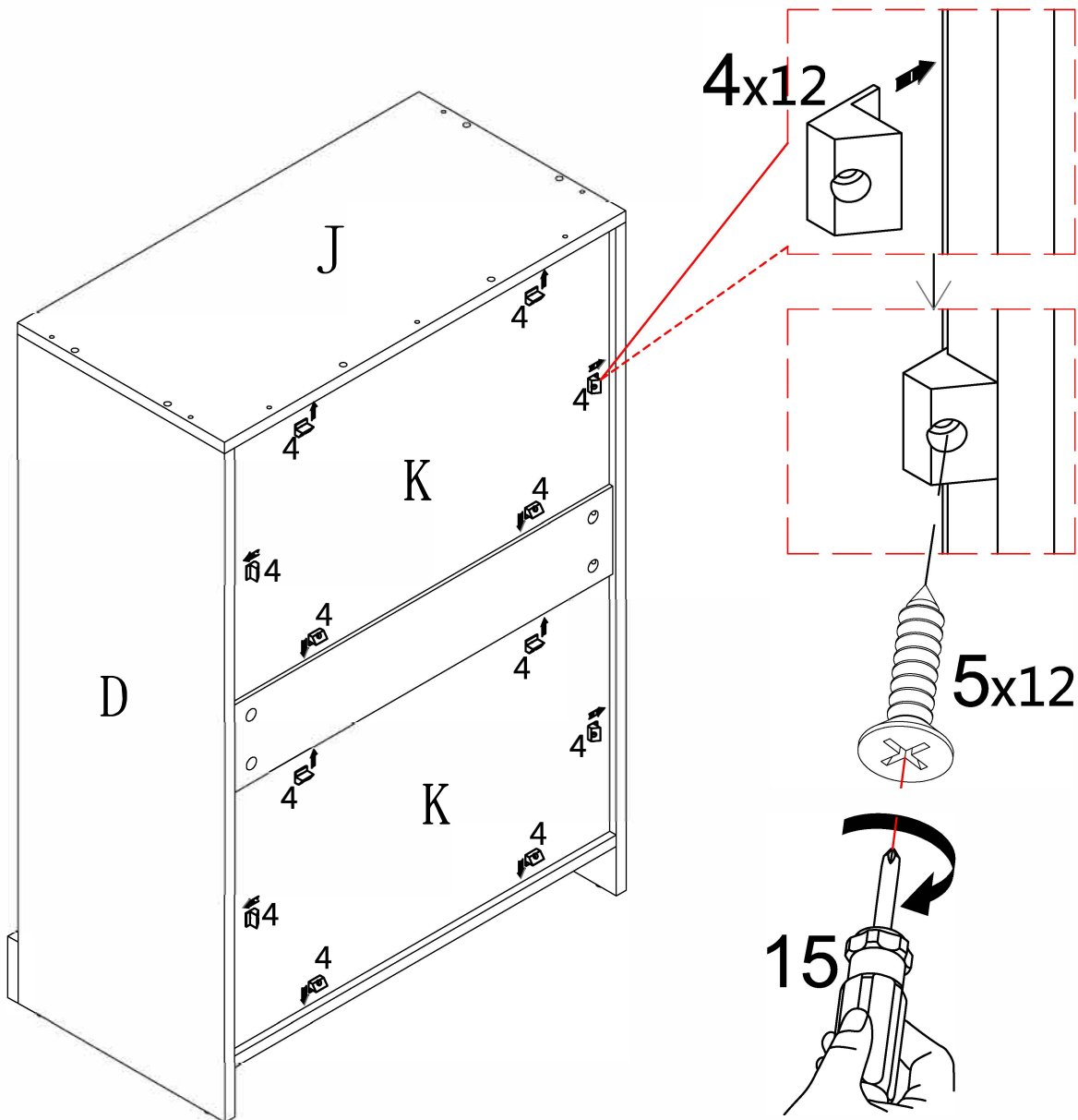
1. Insert 12x parts(#4) and 12x (#5) screws into the panel (K) with screwdriver (#15).
2. Fully tighten all screws and verify structural stability.

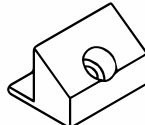

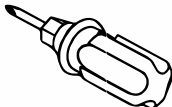
#4	x12	#5	x12	#15	x1
					
		ø3*16mm*6#			

ASSEMBLY INSTRUCTIONS

STEP-10

1. Make sure all holes aligned and use screw (#1) to attach them, tighten screw (#1) with screwdriver (#15)

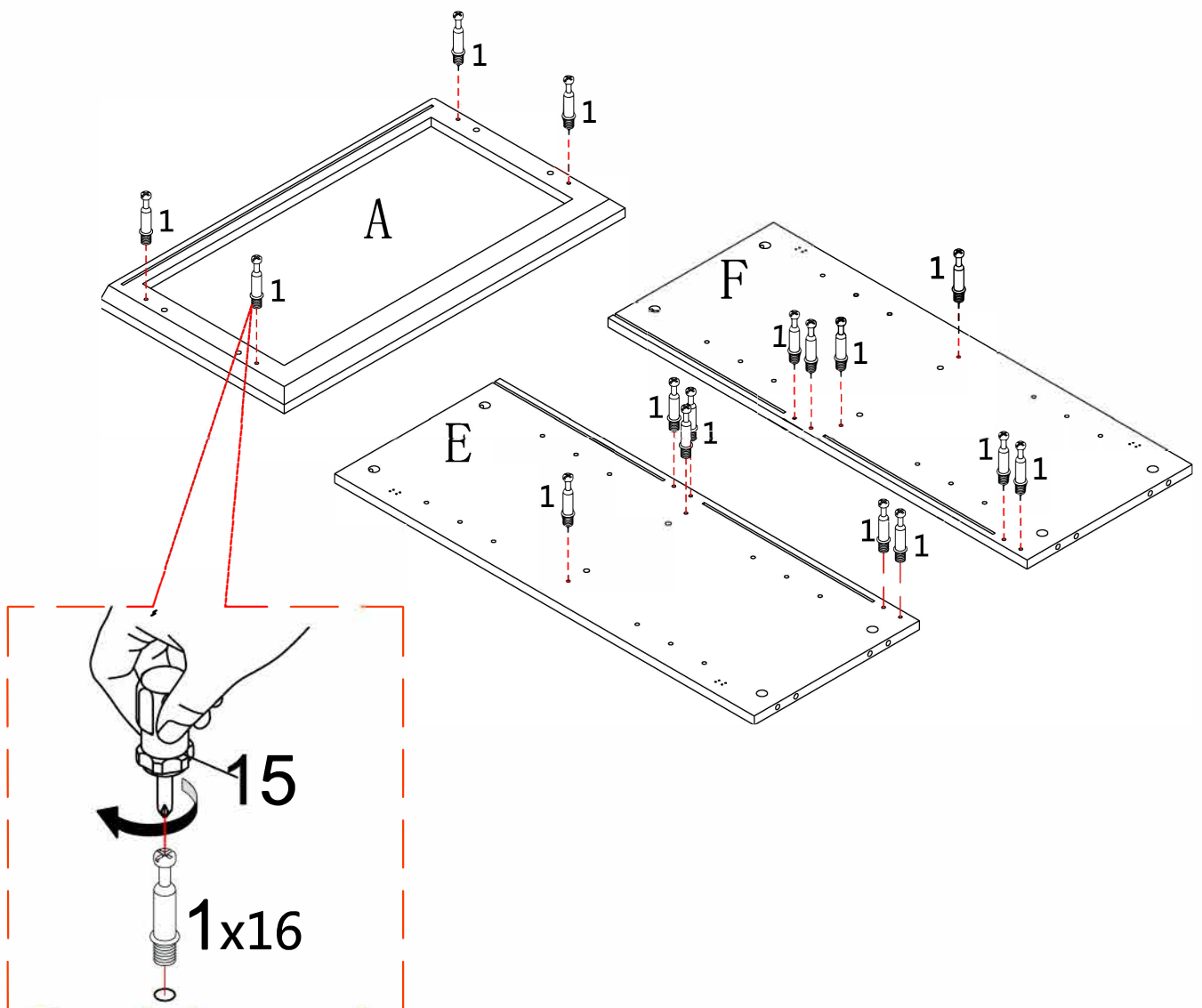

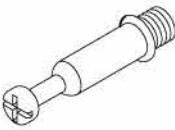
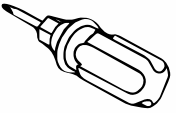
#1	x16	#15	x1
			

ASSEMBLY INSTRUCTIONS

STEP-11

1. Insert two cam locks (#2) into the pre-drilled holes on the inner face of each side panel (M) and (N), arrow pointing toward the bolt entry.

2. Insert panel (M),(N) into side panel (E) and Using screwdriver (#15), rotate each cam lock 180° clockwise until it clicks and tightens.

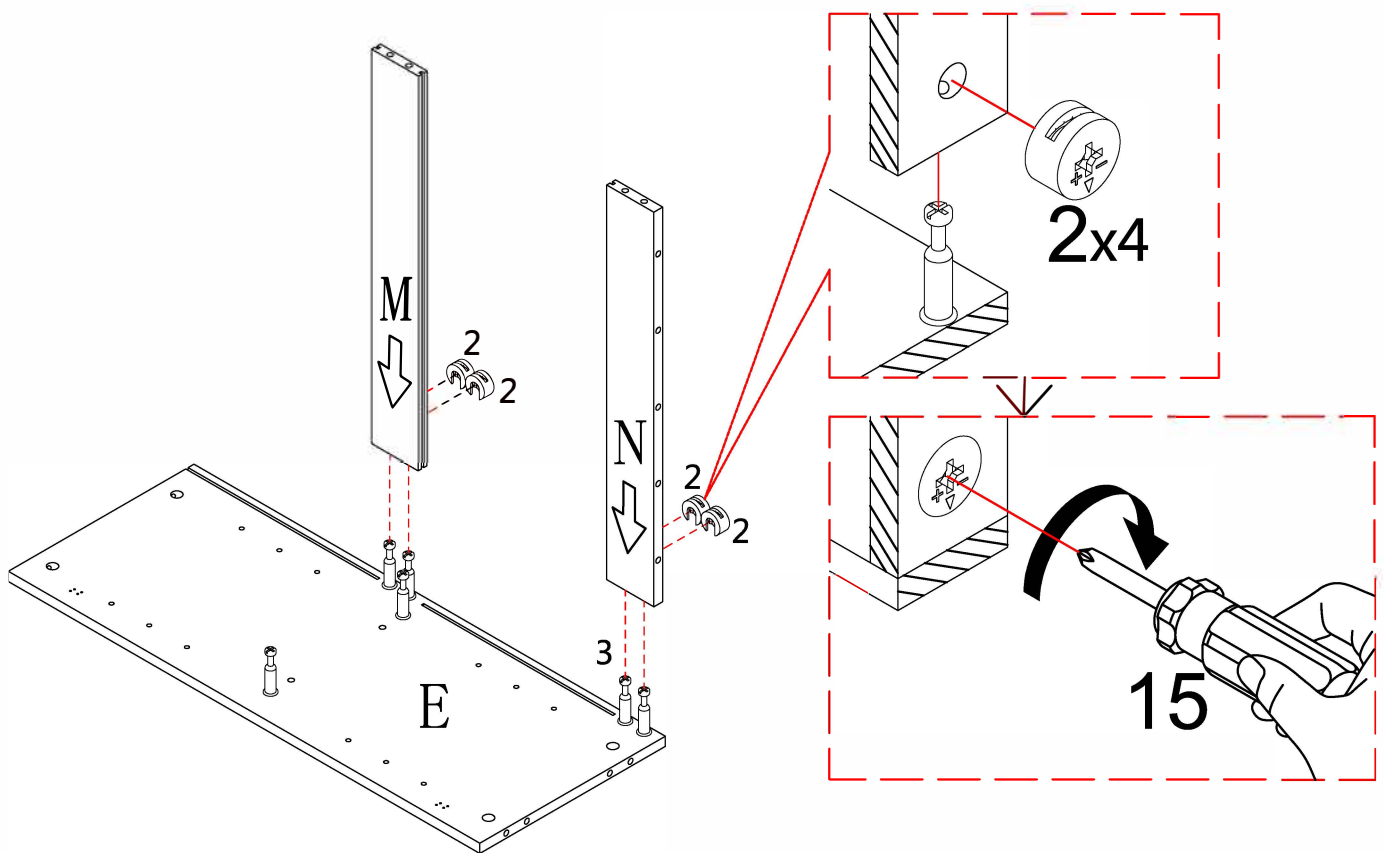

#2	x4	#15	x1

ASSEMBLY INSTRUCTIONS

STEP-12

1. Insert 2x cam locks (#2) into the large, pre-drilled holes on the inner face of side panel (L), arrow pointing toward the bolt entry.
2. Push 2x dowels (#3) into the matching holes on the left side of bottom panel (E).
3. Align panel (L) over the 2x connector bolts and dowels, then slide down until flush.
4. Use screwdriver (#15) to rotate each cam 180° clockwise until it clicks and locks.

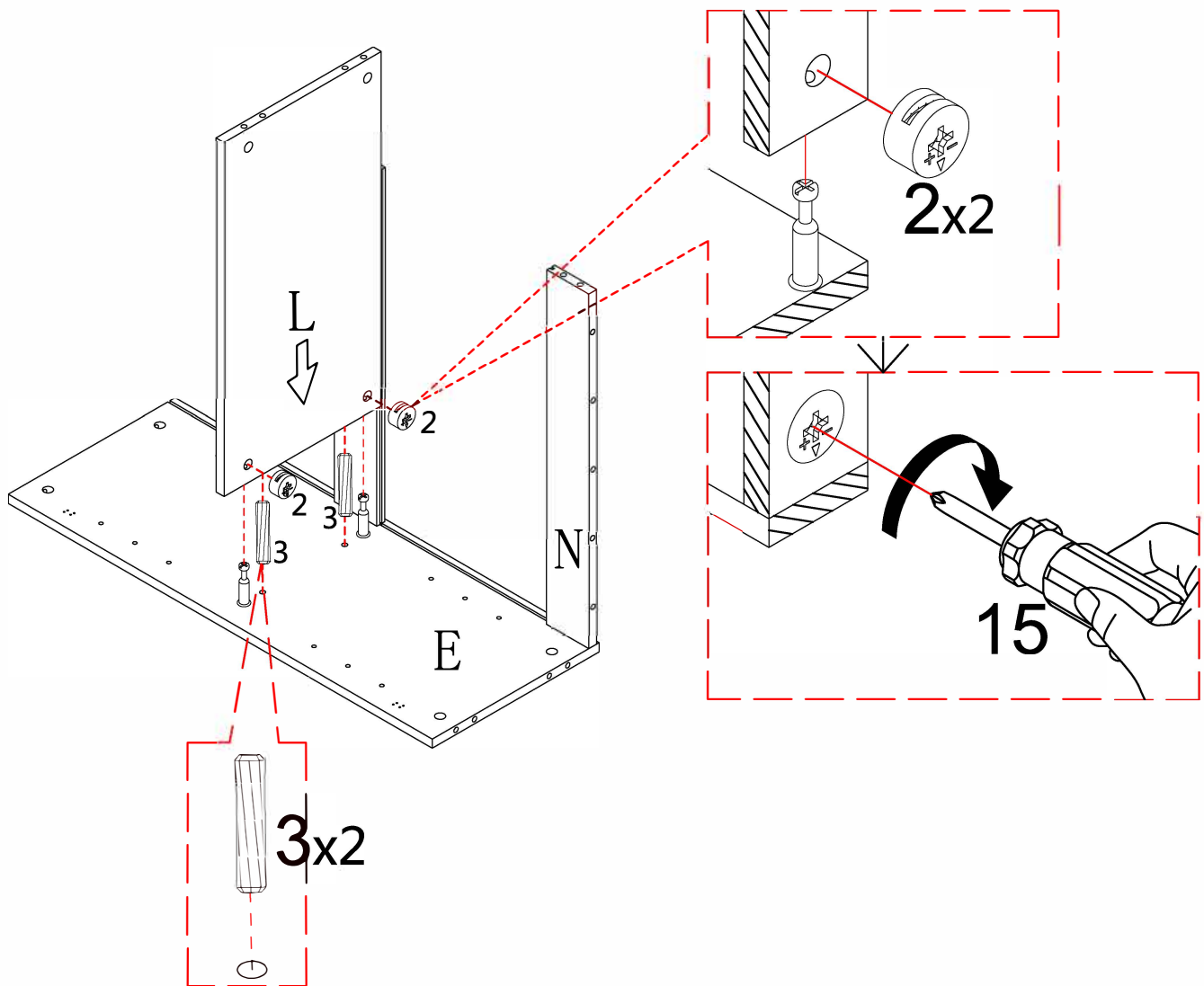

#2	x2	#3	x2	#15	x1
		ø8*30mm			

ASSEMBLY INSTRUCTIONS

STEP-13

1. Slide Panel (O) down into the groove behind the middle shelf. Make sure it fits snugly between Panels (L) and (N), and sits flush in the back.

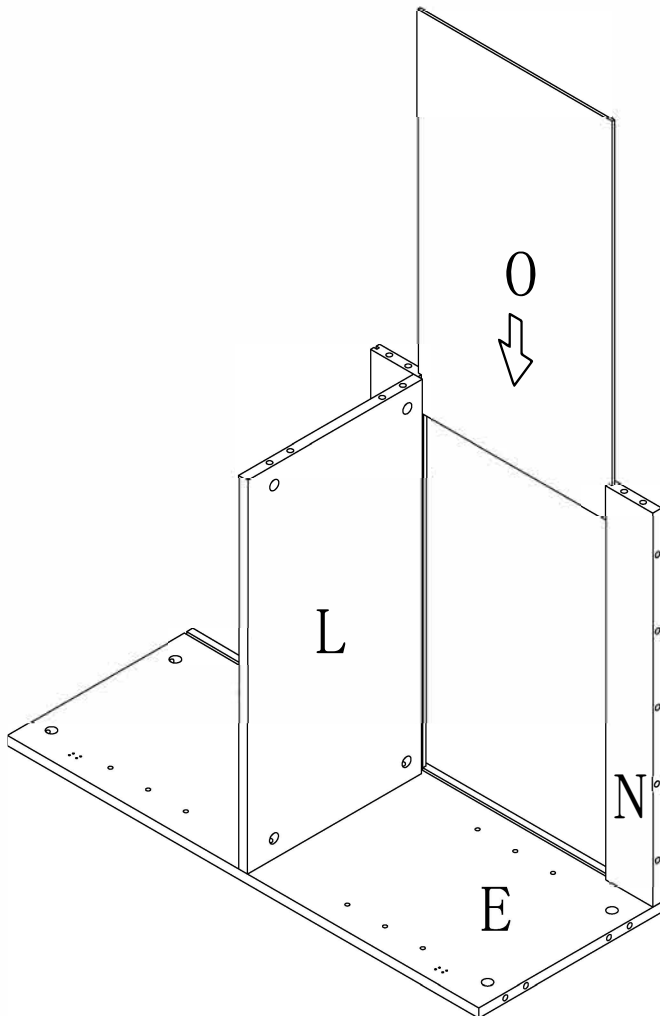

ASSEMBLY INSTRUCTIONS

STEP-14

1. Insert 2x dowels (#3) into the tops of panels (L) .
2. Align and place Panel (F) on top of panels (L),(O), and (N).
3. Insert 6 connector cams (#2) into the holes and tighten with screwdriver (#15).

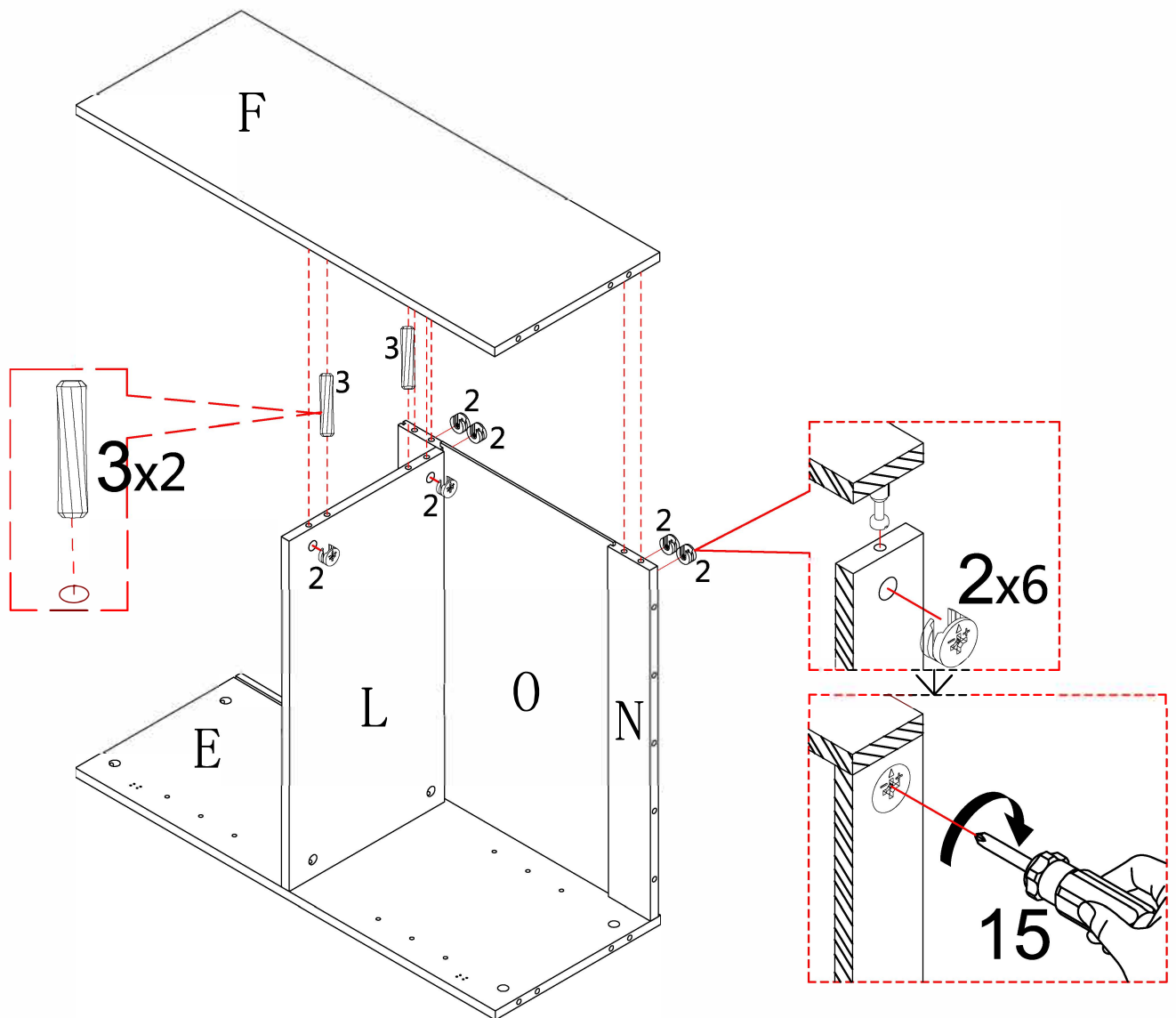

#2	x6	#3	x2	#15	x1
		ø8*30mm			

ASSEMBLY INSTRUCTIONS

STEP-15

1.1. Slide Panel (O) down into the groove behind the middle shelf. Make sure it fits snugly between Panels (E),(L)and (F), and sits flush in the back.

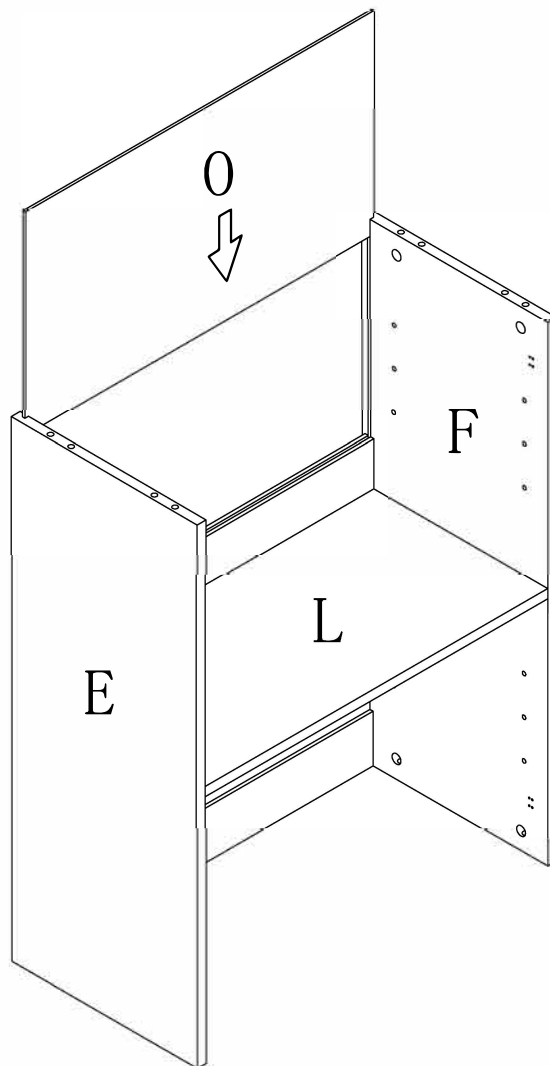

ASSEMBLY INSTRUCTIONS

STEP-16

1. Insert 4x dowels (#3) into the tops of panels (E) and (F).
2. Align and place Panel (A) on top of panels (E), (F), and (O).
3. Insert 4 connector cams (#2) into the holes and tighten with screwdriver (#15).

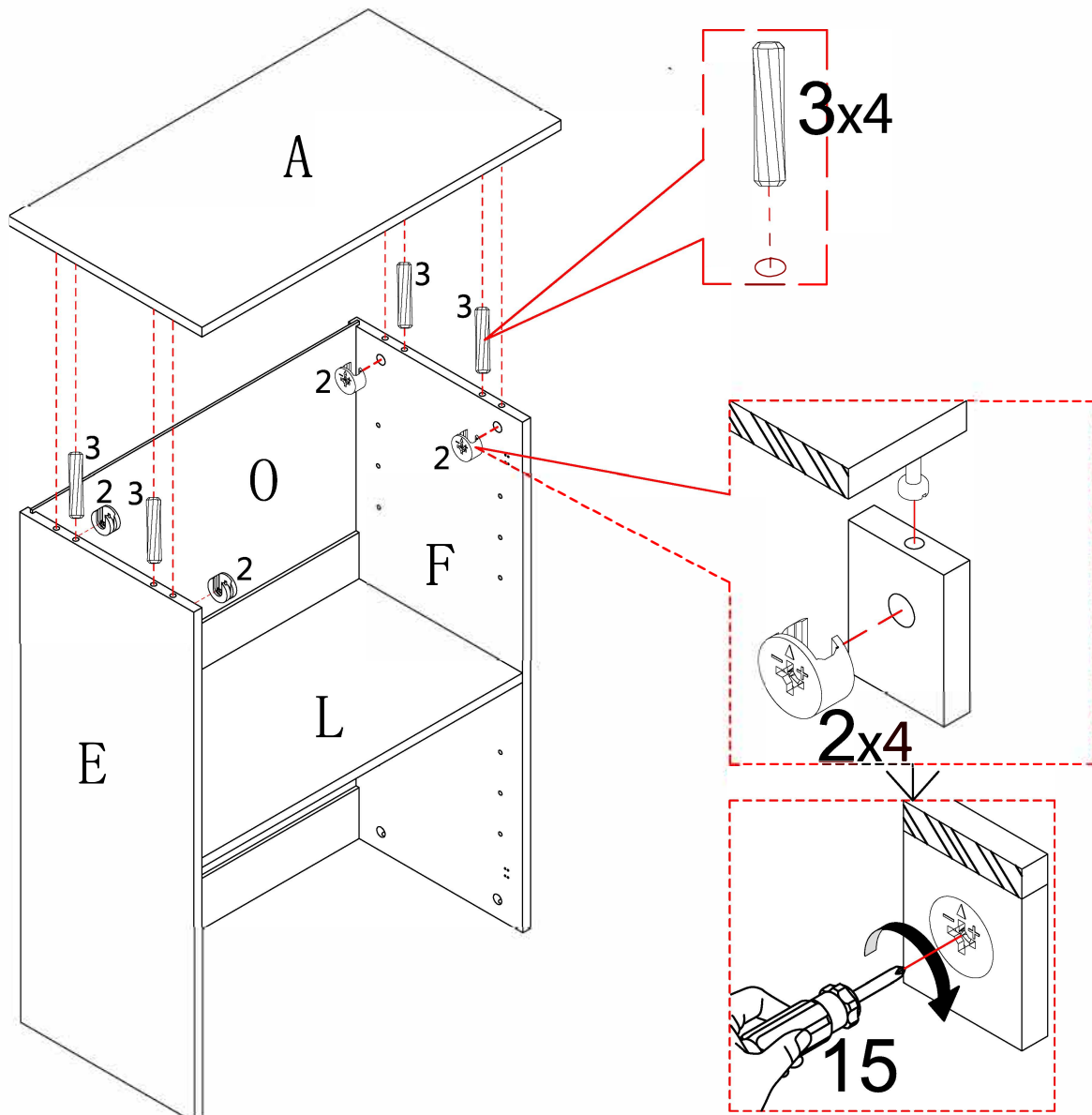



#2	x4	#3	x4	#15	x1
		ø8*30mm			

ASSEMBLY INSTRUCTIONS

STEP-17

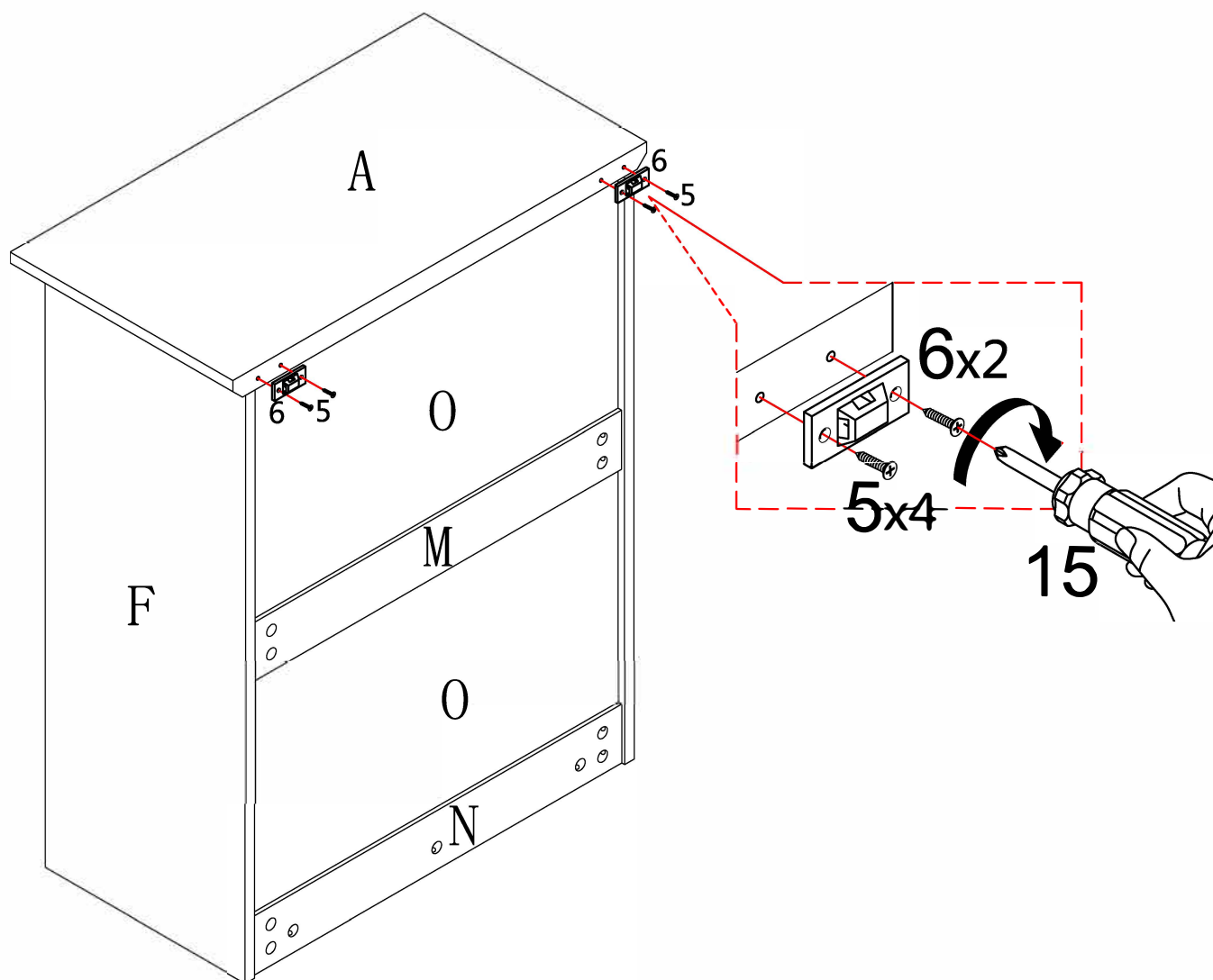
1. Assemble the 2x part (#6) to the side panel (A) using 4x screw (#5), and tighten it with screwdriver (#15).

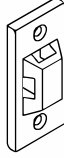

#5	x4
	
φ3*16mm*6#	

#6	x2
	

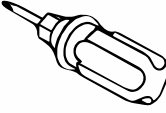

#15	x1
	

ASSEMBLY INSTRUCTIONS

STEP-18

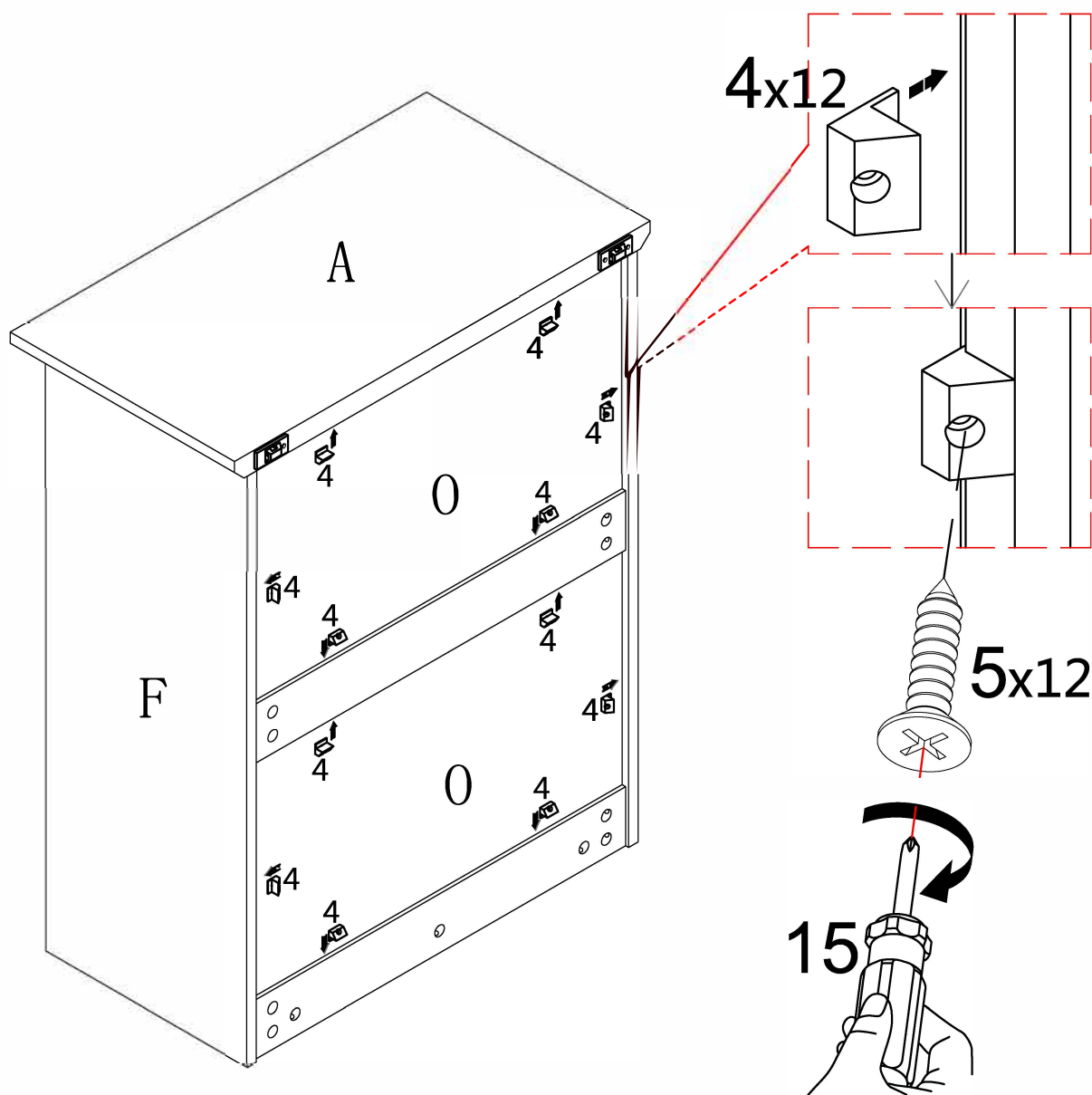
1. Insert 12x parts(#4) and 12x (#5) screws into the panel (O) with screwdriver (#15).
2. Fully tighten all screws and verify structural stability.

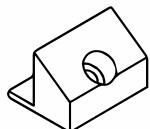

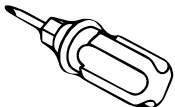
#4	x12	#5	x12	#15	x1
					
		ø3*16mm*6#			

ASSEMBLY INSTRUCTIONS

STEP-19

1. Make sure all holes are aligned and use screw (#1) to attach the panel (J), tighten screw (#1) with screwdriver (#15)

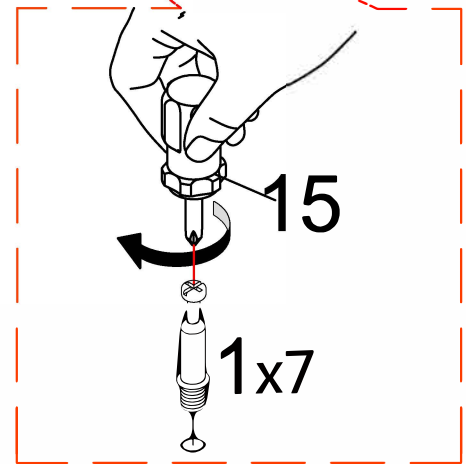
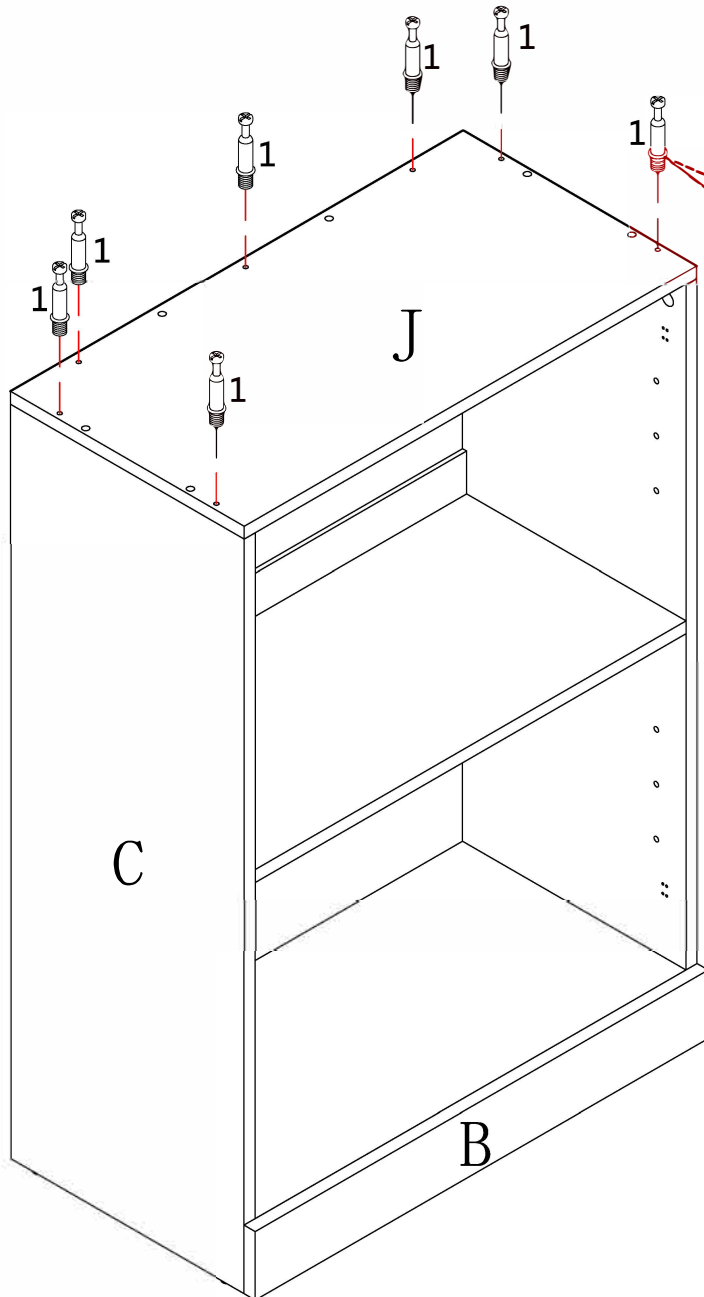

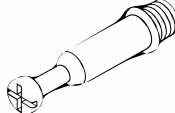
#1	x7
	

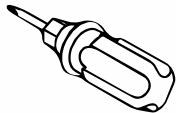
#15	x1
	

ASSEMBLY INSTRUCTIONS

STEP-20

1. Insert 6x dowels (#3) into the designated holes at the bottom edge of panel (J)
2. Insert part (A-E) into top panels (J) on the part (J-C)
3. Insert 7x connector cam (#2) into the holes and tighten with screwdriver (#15).

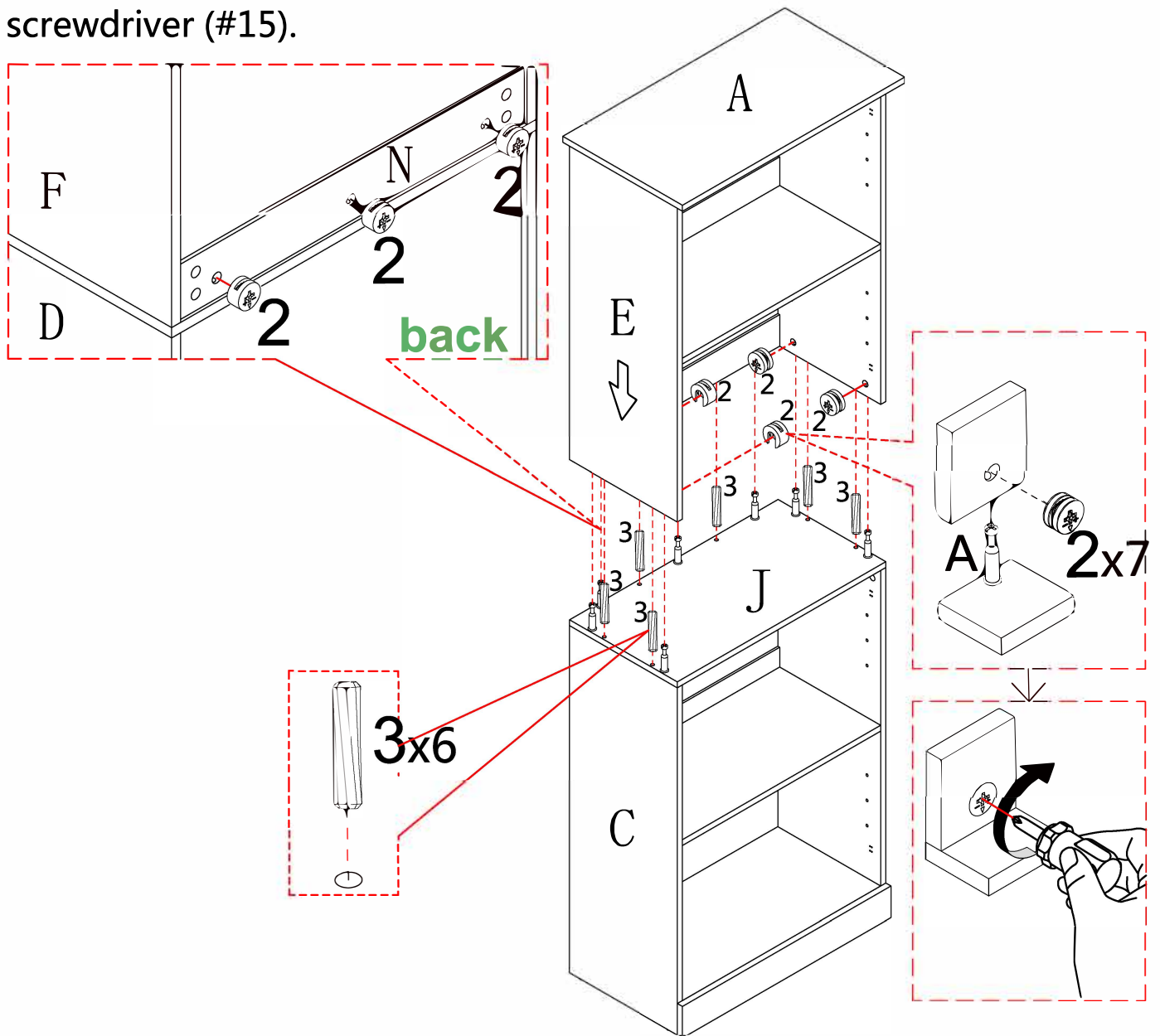

#2	x7	#3	x6	#15	x1
		ø8*30mm			

ASSEMBLY INSTRUCTIONS

STEP-21

1. Push 16x dowels (#7) into the matching holes
2. Place 4x panel (P) on each top of shelf holder (#7)

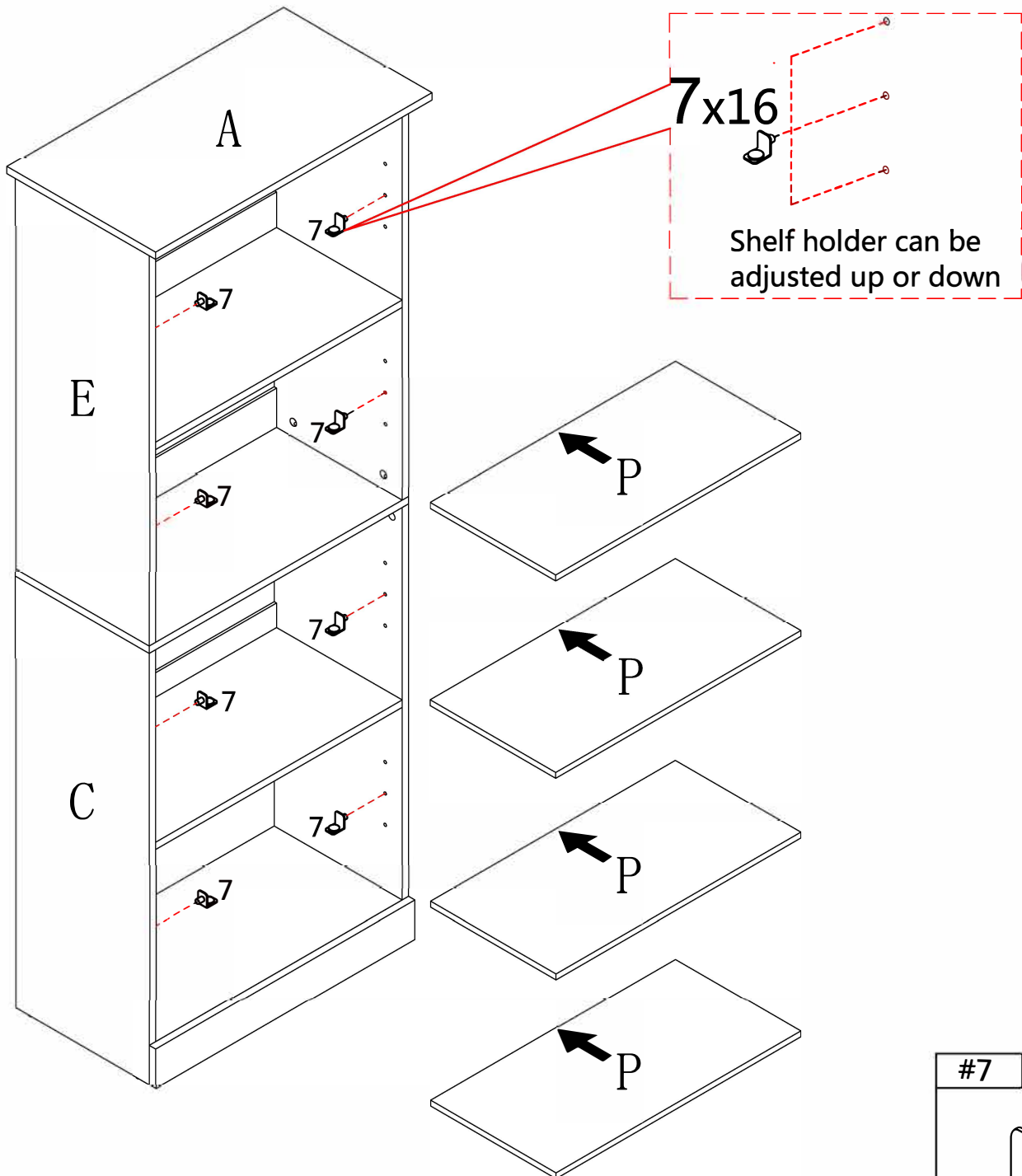

#7	x16

ASSEMBLY INSTRUCTIONS

STEP-22

1. Secure hinges to each of the 2x (Q) panels with 4x(#8) hinges and 8x (#9)screws in pre-drilled holes.
2. Attach the 2x (#10) door handles to each of the 2x door panels (Q) with 4x (#11) screws.
3. Tighten all screws fully with screwdriver (#15).

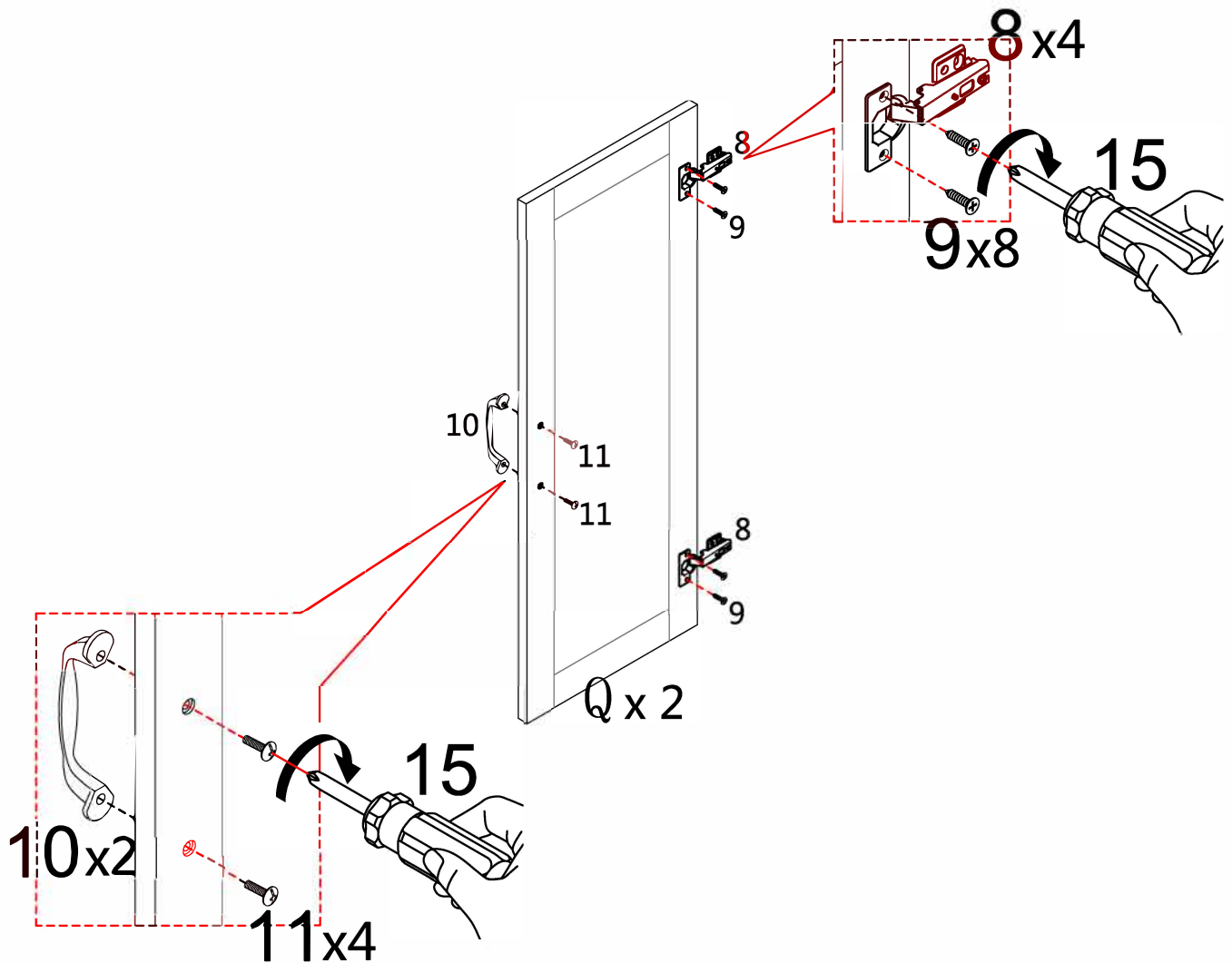

#8	x4	#9	x8	#10	x2	#11	x4	#15	x1
		ø3.5*14mm*7#				ø4*19mm			

ASSEMBLY INSTRUCTIONS

STEP-23

1. Secure hinges to each of the 2x (R) panels with 4x(#8) hinges and 8x (#9) screws in pre-drilled holes.
2. Attach the 2x (#10) door handles to each of the 2x door panels (R) with 4 (#11) screws.
3. Tighten all screws fully with screwdriver (#15).

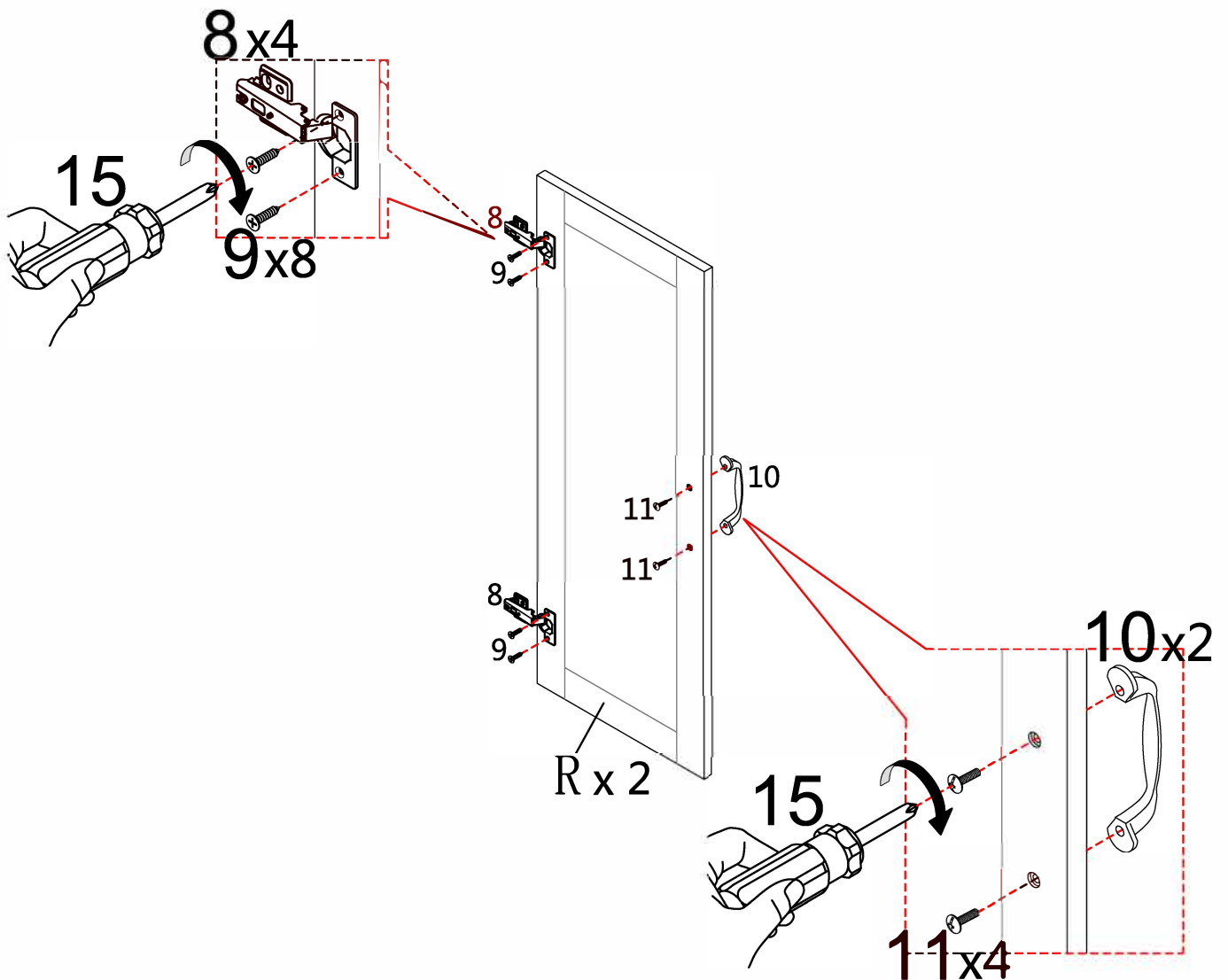



#8	x4	#9	x8	#10	x2	#11	x4	#15	x1
		ø3.5*14mm*7#				ø4*19mm			

ASSEMBLY INSTRUCTIONS

STEP-24

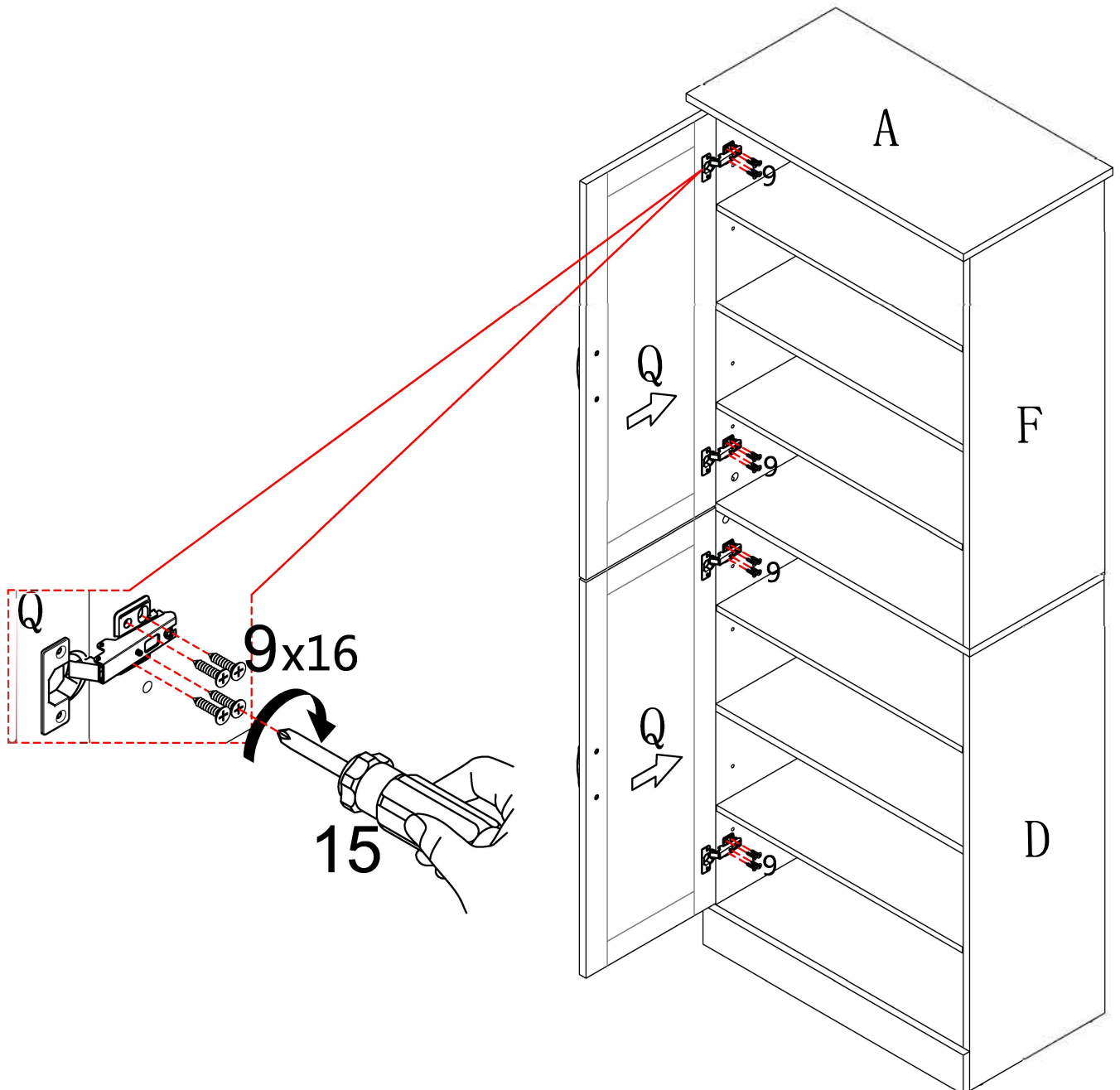
Attach the 2x door panel (Q) to the cabinet with 16x screws (#9) through the holes reserved for the hinges.



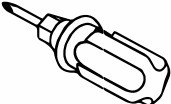

#9	x16	#15	x1
			
ø3.5*14mm*7#			

ASSEMBLY INSTRUCTIONS

STEP-25

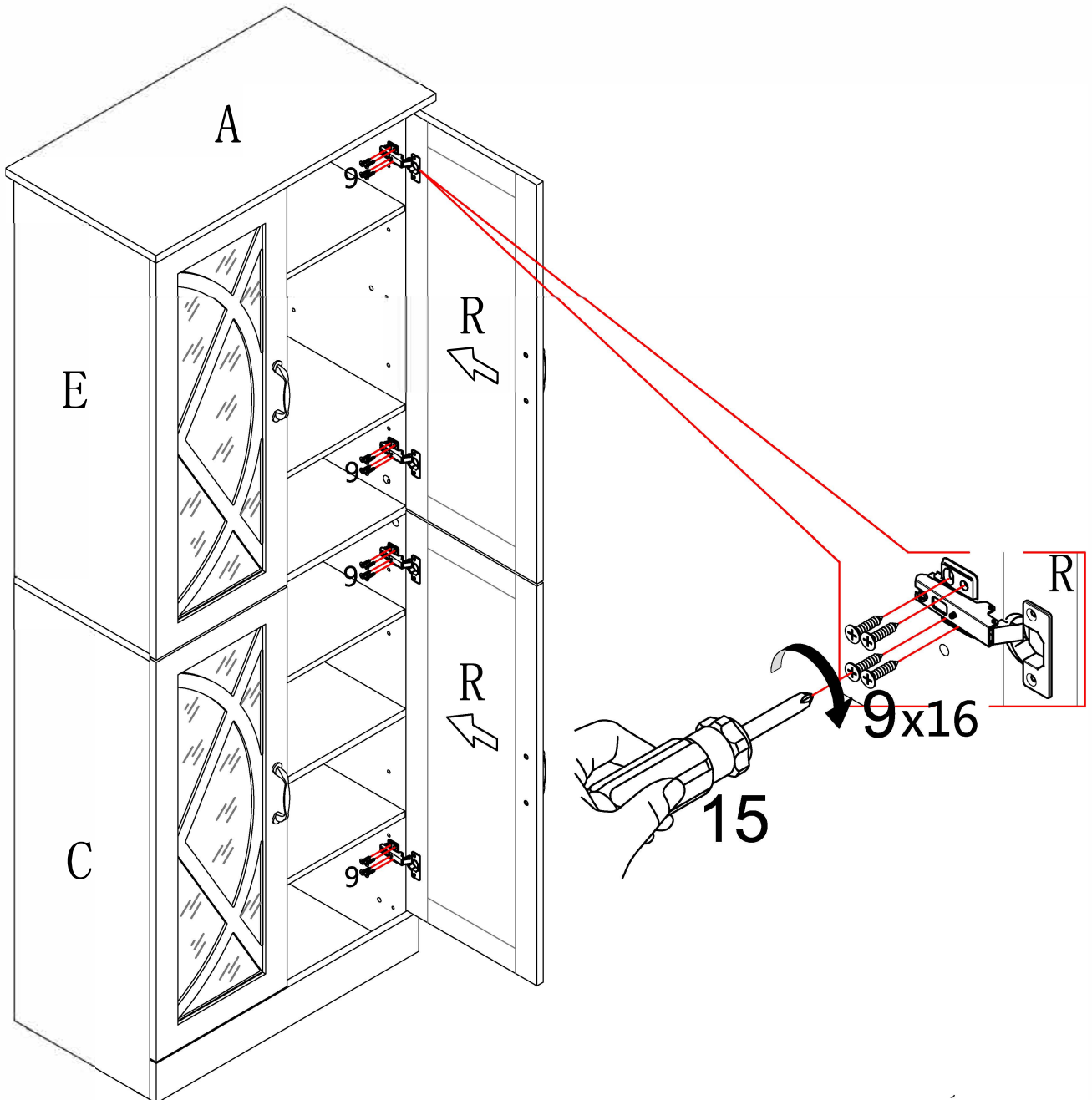
Attach the 2x door panel (R) to the cabinet with 16x screws (#9) through the holes reserved for the hinges.

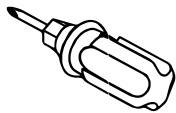

#9	x16	#15	x1
			
ø3.5*14mm*7#			

ASSEMBLY INSTRUCTIONS

STEP-26

Concealed hinges are three-way adjustable:

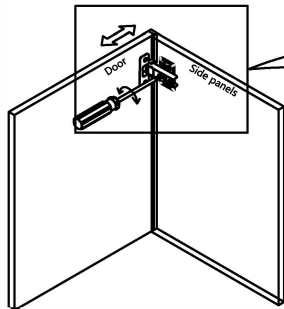

Horizontal
by screw adjustment!

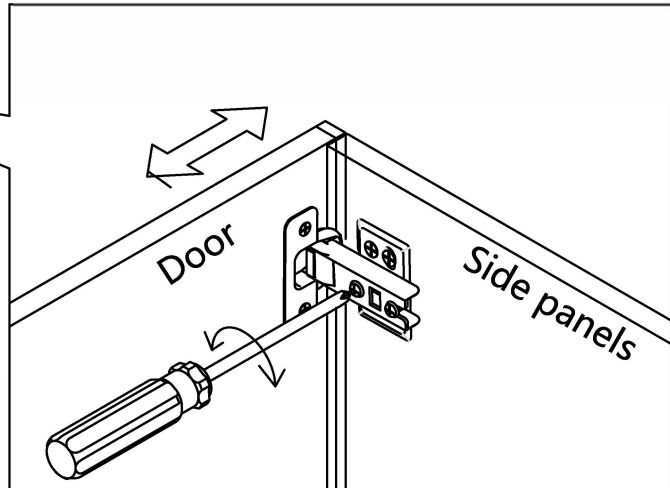

Concealed hinges are three-way adjustable:

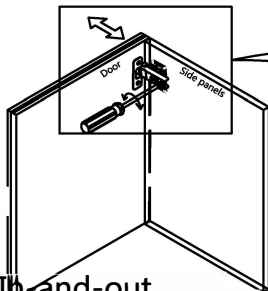

In and-out
by loosening the hinge arm
mounting screw or via cam
adjustment!

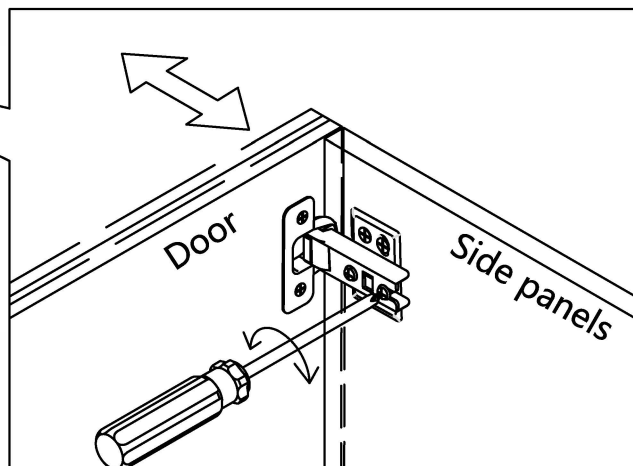

Concealed hinges are three-way adjustable:

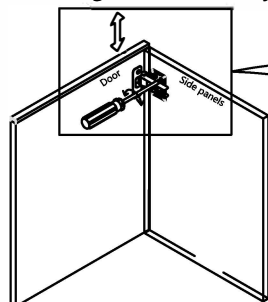

Vertical via slots in
the mounting plate
or via cam adjustment!

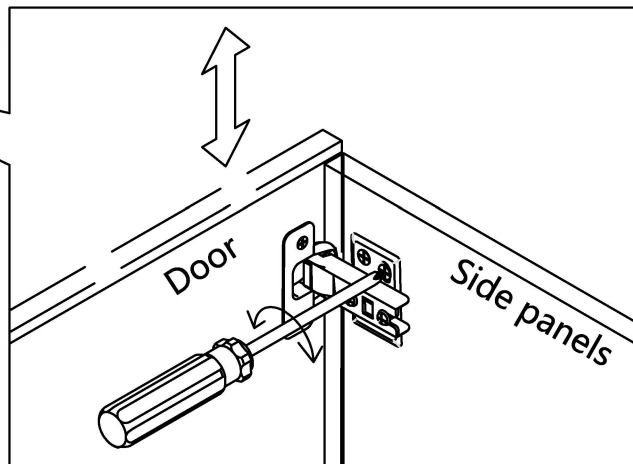

Hinge adjustment method

ASSEMBLY INSTRUCTIONS

STEP-27 1.mark the position on the wall,that corresponds to the location of part(#6); Drill and insert the expandable screw (#12) by hammer.

2.Assemble the part (#6) to the wall. align the hole in the part (#6) with the expandable screw (#12), use screw (#13) to attach it and tighten by screwdriver (#15)

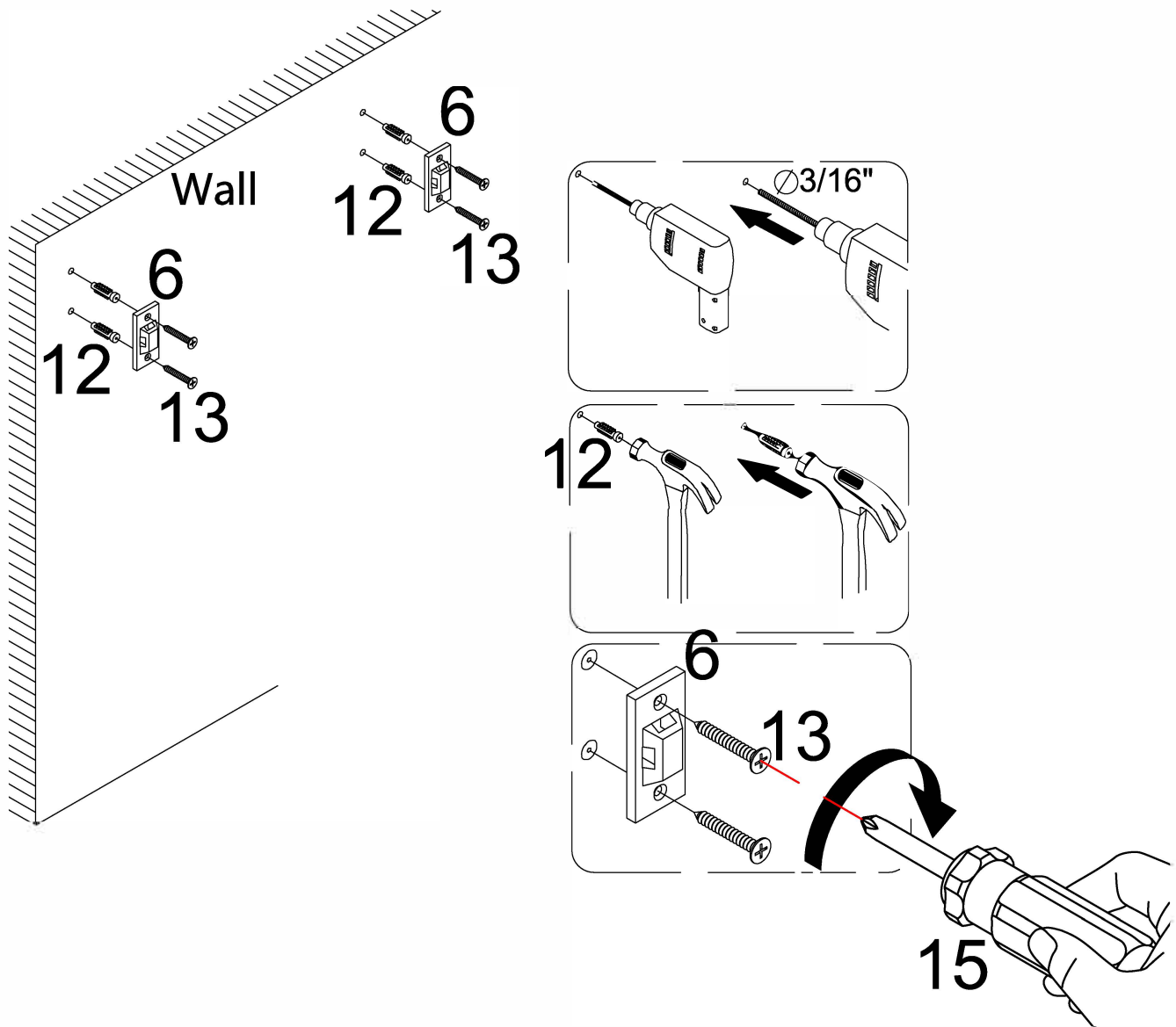

#6	x2

#12	x4

#13	x4
ø3.5*35mm*7#	

#15	x1

ASSEMBLY INSTRUCTIONS

STEP-28

1. Let the plastic belt (#14) pass through the both part (#6) and pull tightly.

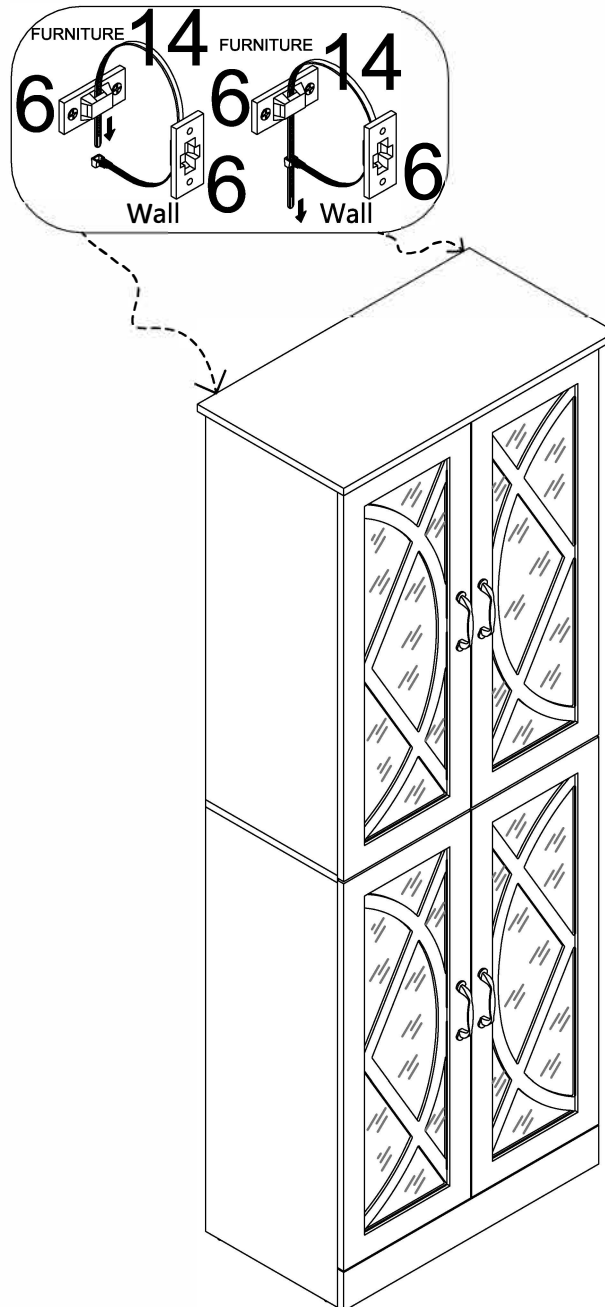

#14	x2
	

WARRANTY

1. We strive to offer high-quality products, and we also try our best to satisfy each and every customer that orders from us with product or service as needed.
2. We provide 30 days warranty starting from the time you receive the item. Each customer must provide a record of their order such as the order number, or item receipt for any items that are out of the warranty period you may also still receive.
3. Replacement parts by purchasing them with our company if they are available.

Are you having difficulty
With assembly? Missing parts?
Please send email with your order No to
hubeihongmao@163.com
For return, please check the return policy with
the retailer or market place you bought from.

Appreciate your purchasing from us.
Pop up your life by our furniture piece!