

OWNER MANUAL

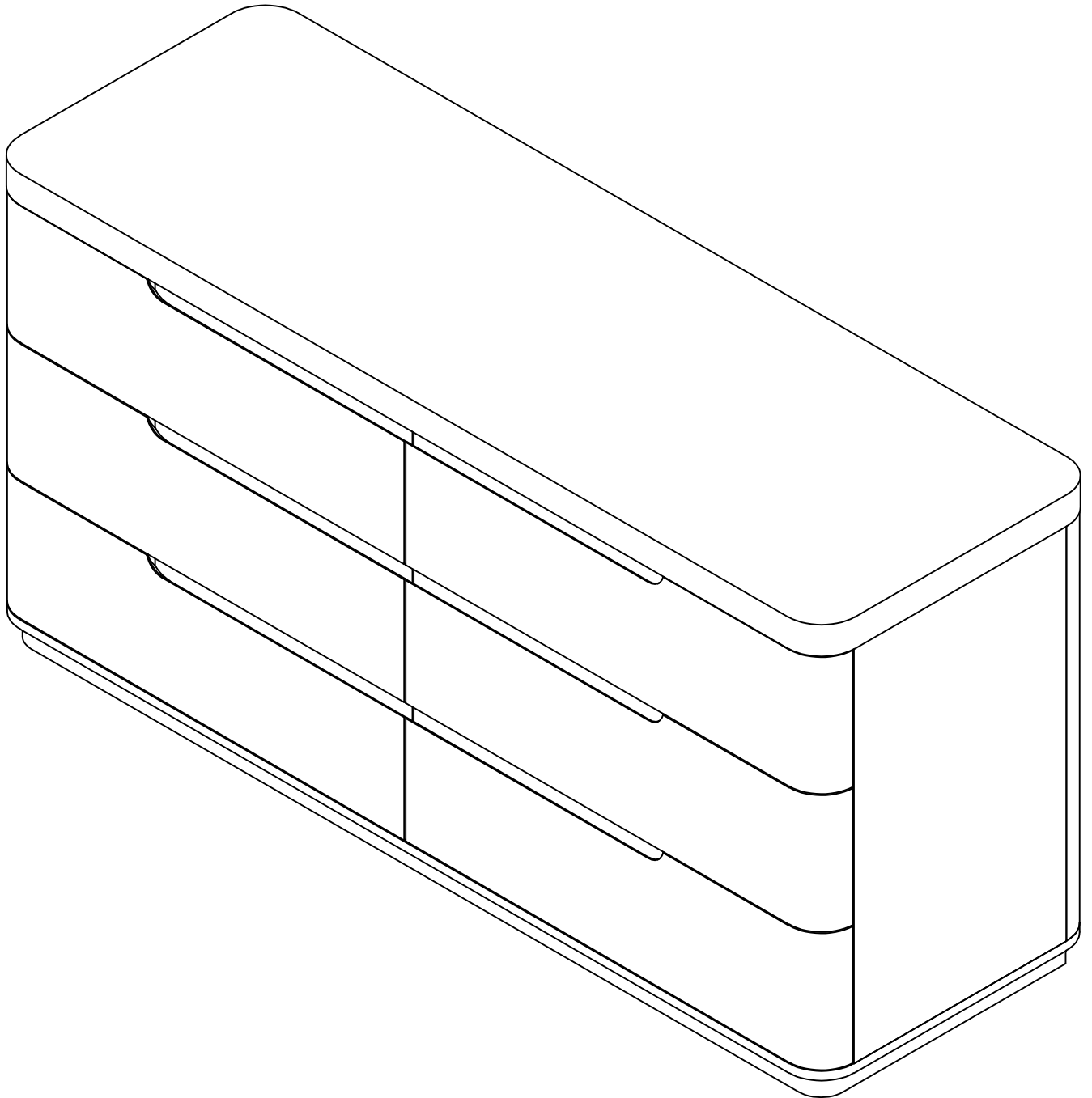

NOTE:

This brochure contains IMPORTANT safety info. Please read and keep for future reference.

MAINTENANCE AND WARNING



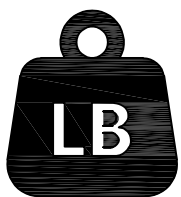

- 1.Keep furniture away from heat sources.
- 2.Do not clean furniture with harsh cleaner or polishes.Do not use detergents,solvents,abrasives,spray packs or leather cleaner. Use non-color mild soa with warm water to clean spills(Mix 1:10 soap to water).
- 3.Do not place furniture under direct sunlight,material will possibly fade over time.
- 4.Do not use on site dry cleaning machine.Children should not climb or jump on the furniture.
- 5.Do not write on furniture that is not protectedby a padded barrier.
- 6.Not for commercial use,only for residential use.



Weight Limitation

100 LBS

HARDWARE LIST

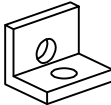
#1	x2	#2	x2	#3	x2	#4	x2	#5	x4
									
		Ø3.5*35mm		Ø3.5*16mm					

TOOL LIST

#6	x1
	

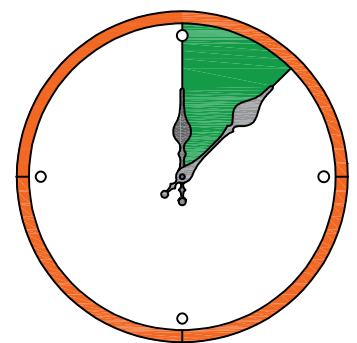

Around 20 min

ASSEMBLY INSTRUCTIONS

STEP-1

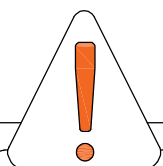

Attention:
Before the next step, adjust the feet of the locker to keep it level.

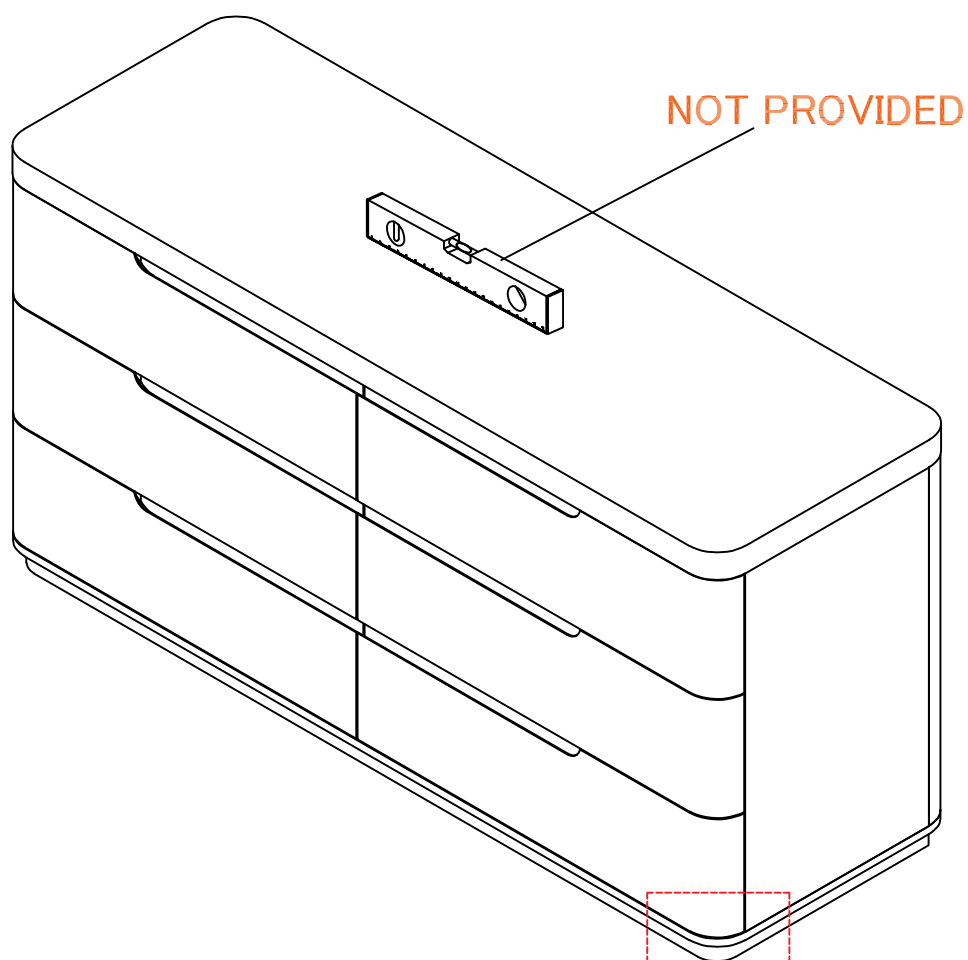

NOT PROVIDED

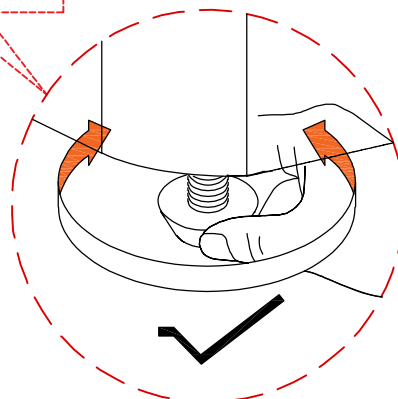
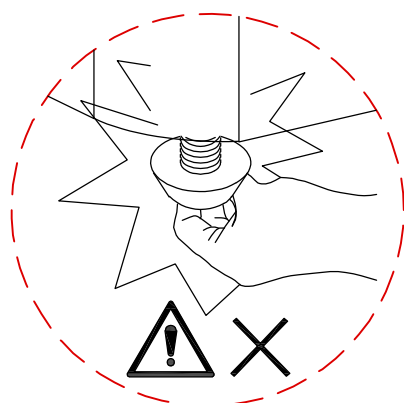

ASSEMBLY INSTRUCTIONS

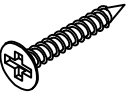
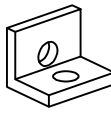
#3	x2	#5	x2
			
Ø3.5*16mm			

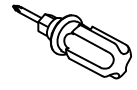

#6	x1
	

STEP-2

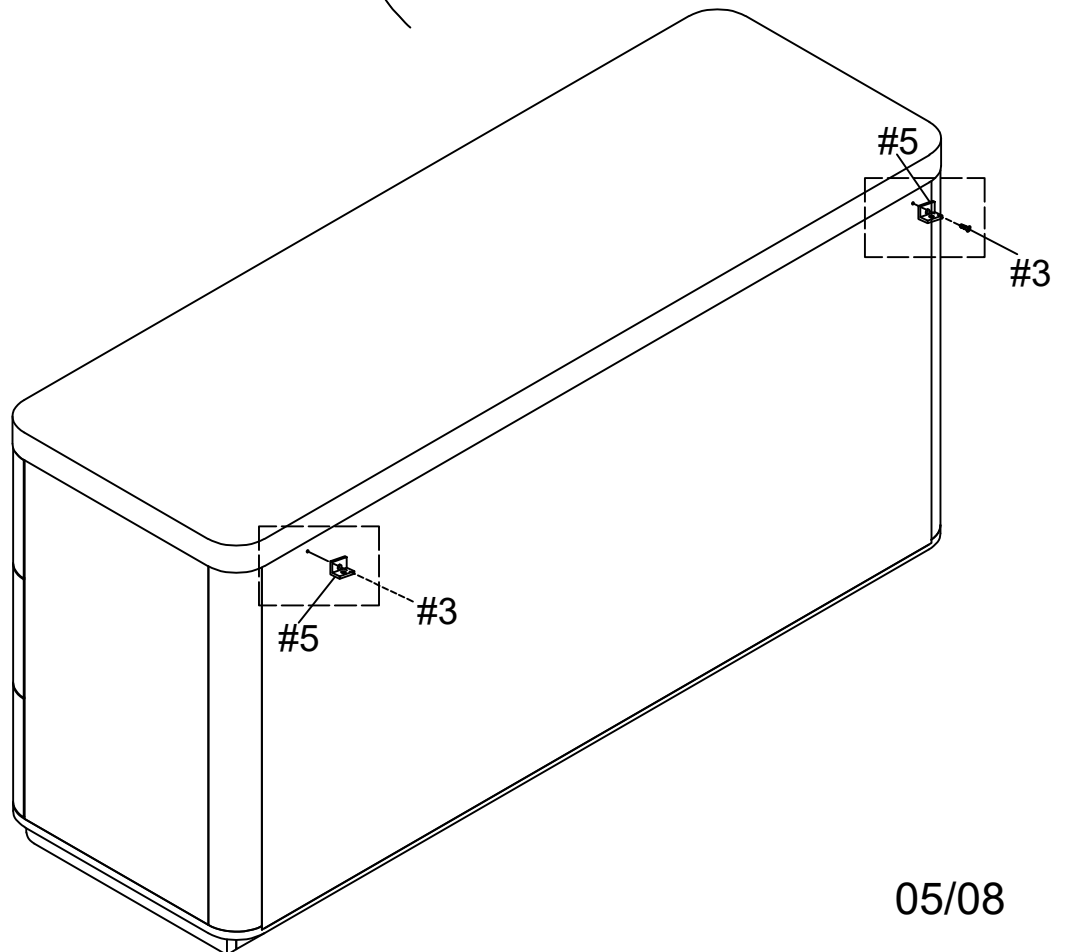
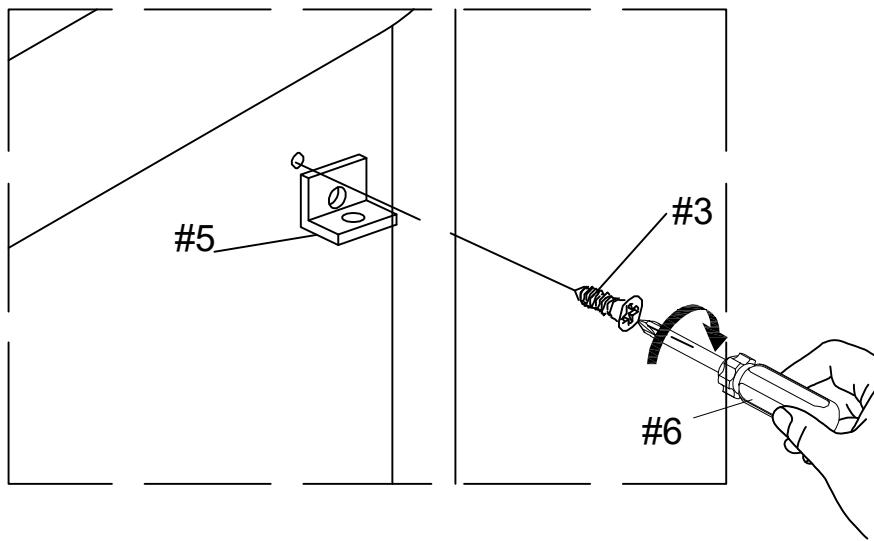
1. Use screw #3 to attach part #5 to the dresser, tighten screws with screwdriver #6.

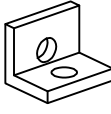

ASSEMBLY INSTRUCTIONS

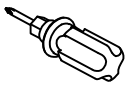
#1	x2	#5	x2	#2	x2	#6	x1
				 Ø3.5*35mm			

STEP-3

1. Install the anti-collapse device.
2. Mark the position on the wall, that corresponds to the location of part #5 on the back of the dresser; Drill and insert the expandable screw #1 by hammer.
3. Assemble the part #5 to the wall. Align the hole in the part #5 with the expandable screw #1, use screw #2 to attach it and tighten by screwdriver #6.

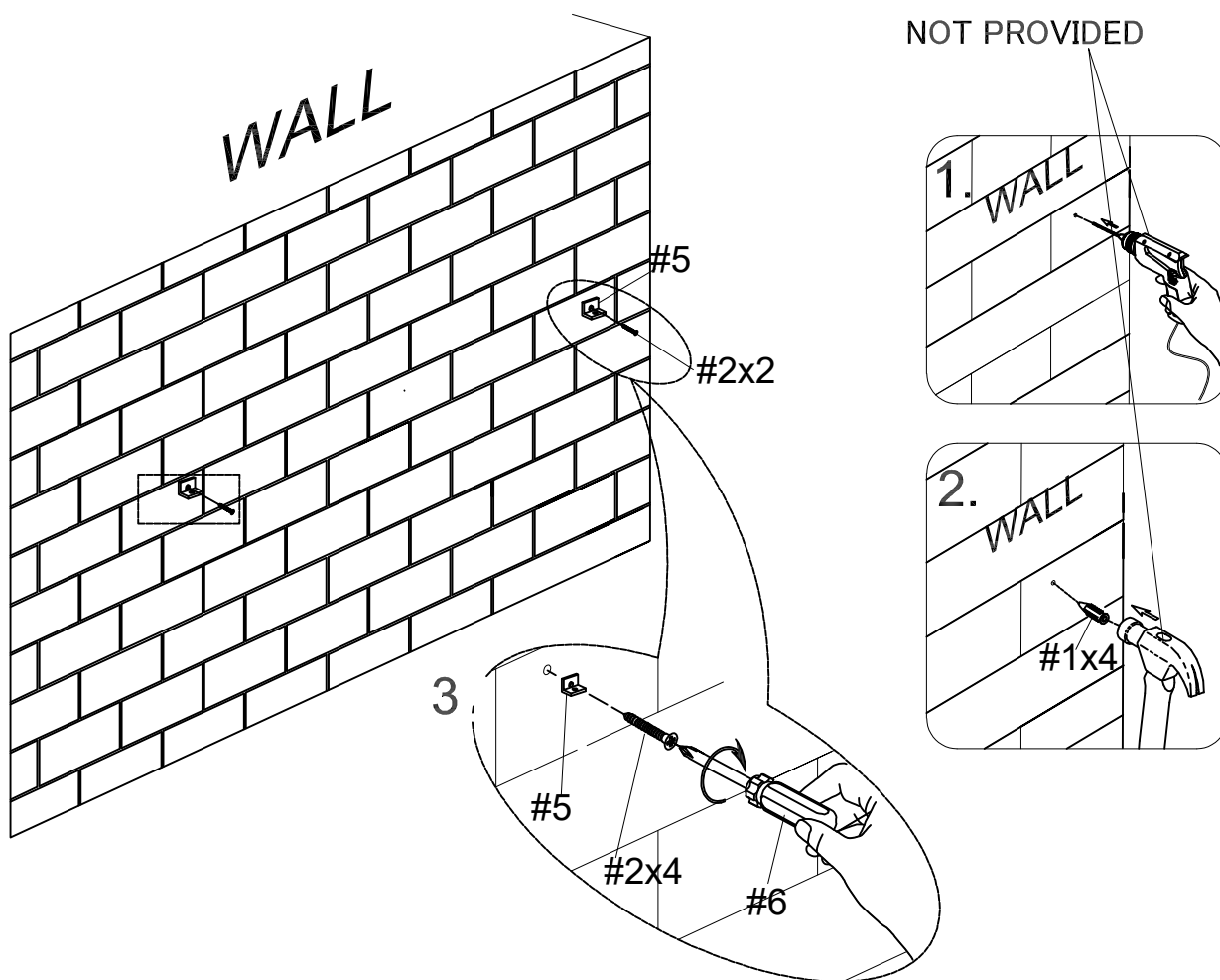

ASSEMBLY INSTRUCTIONS

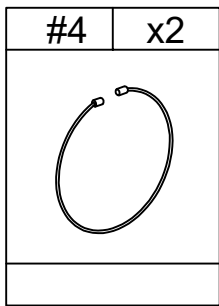

STEP-4

1. Let the steel belt #4 pass through the both part #5 and lock it .

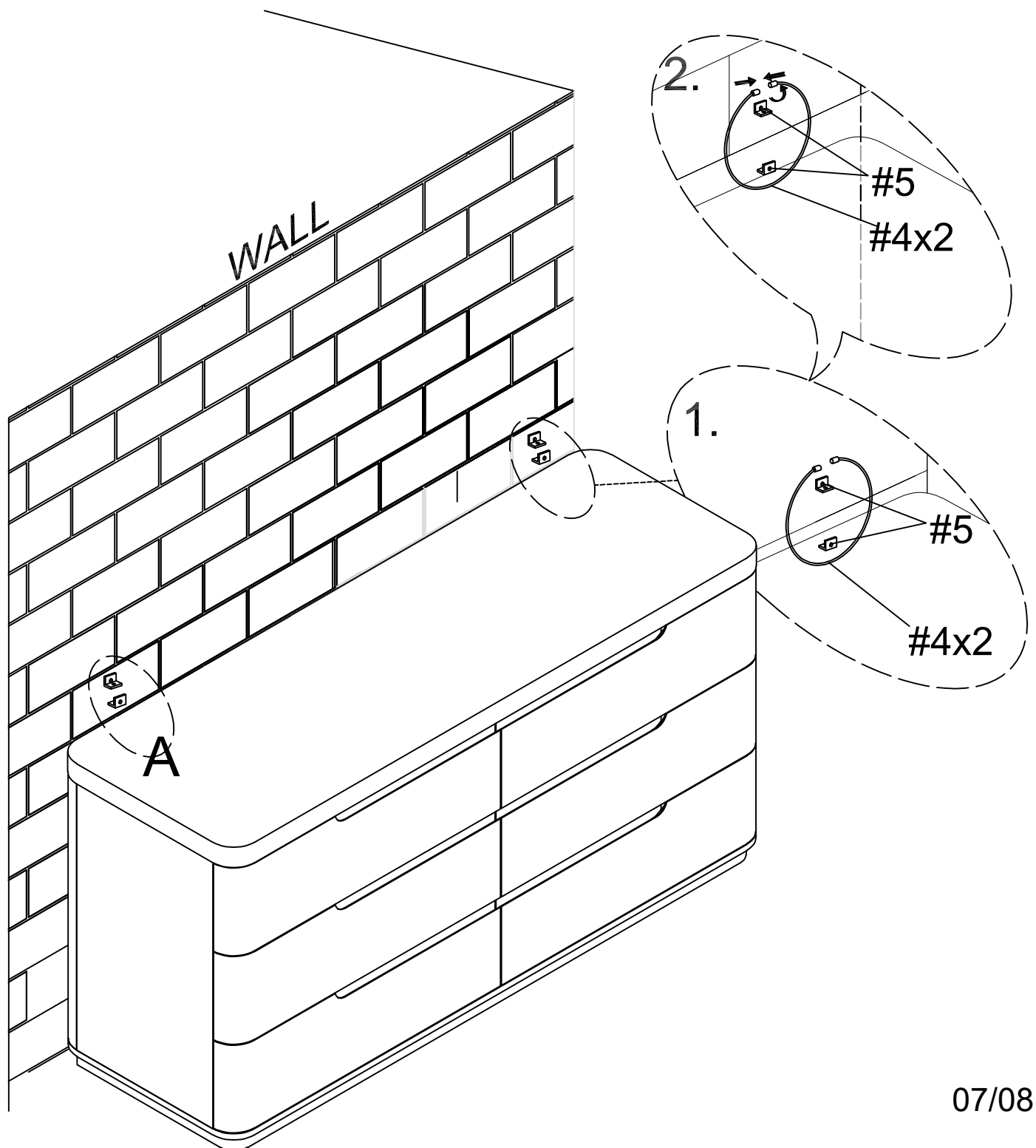

WARRANTY

1. We strive to offer high-quality products, and we also try our best to satisfy each and every customer that orders from us with product or service as needed.
2. We provide 30 days warranty starting from the time you receive the item. Each customer must provide a record of their order such as the order number, or item receipt for any items that are out of the warranty period you may also still receive.
3. Replacement parts by purchasing them with our company if they are available.