

# CHAIR & TABLE COMPANY

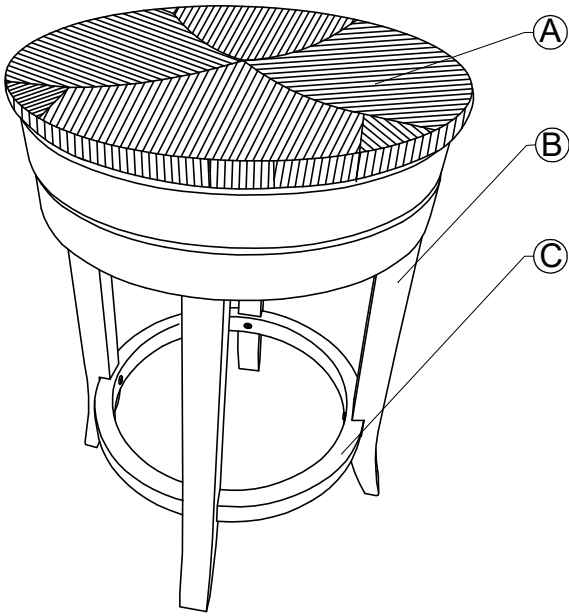



## ASSEMBLY INSTRUCTION



## PARTS CHECK LIST

CODE	COMPONENTS	Q'TY
(A)	SEAT	x01
(B)	LEGS	x04
(C)	FOOT RING	x01

## FITTINGS CHECK LIST

CODE	DESCRIPTION	Q'TY
(D)	 JCBC M6 x 35mm	x08
(E)	 JCBC M6 x 40mm	x04
(F)	 SPRING WASHER M6	x12
(G)	 FLAT WASHER M6	x08
(H)	 ALLEN KEY M4	x01

1. Assemble legs (B) to the seat (A) with JCBC (D), spring washer (F) and flat washer (G).  
Do not tighten all the way until step 2 is completed.

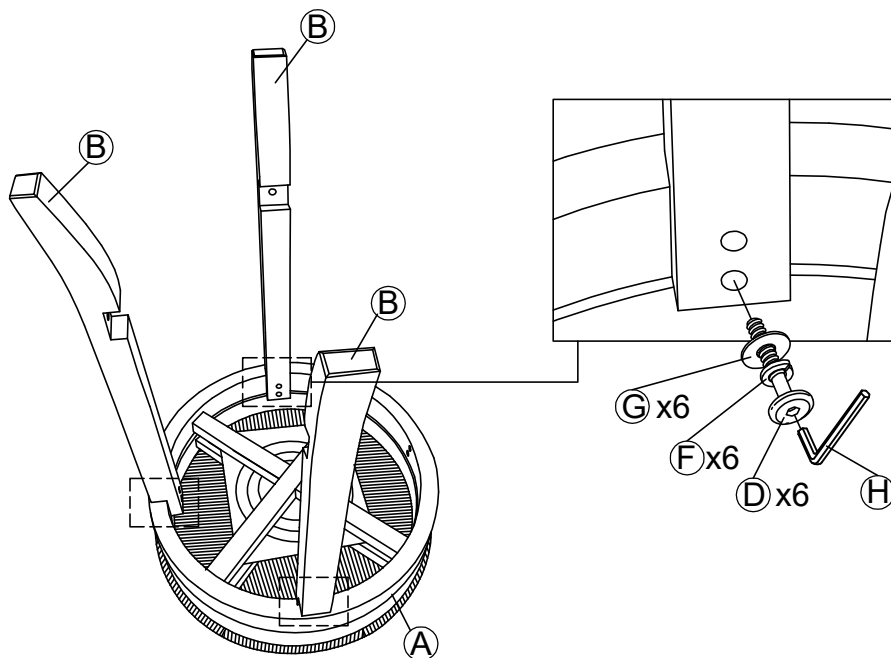

2.

STEP 2 - Tighten the foot ring (C) to leg (B) with JCBC (E) and spring washer (F).

STEP 2.1 - Assemble legs (B) to the seat (A) with JCBC (D), spring washer (F) and flat washer (G).

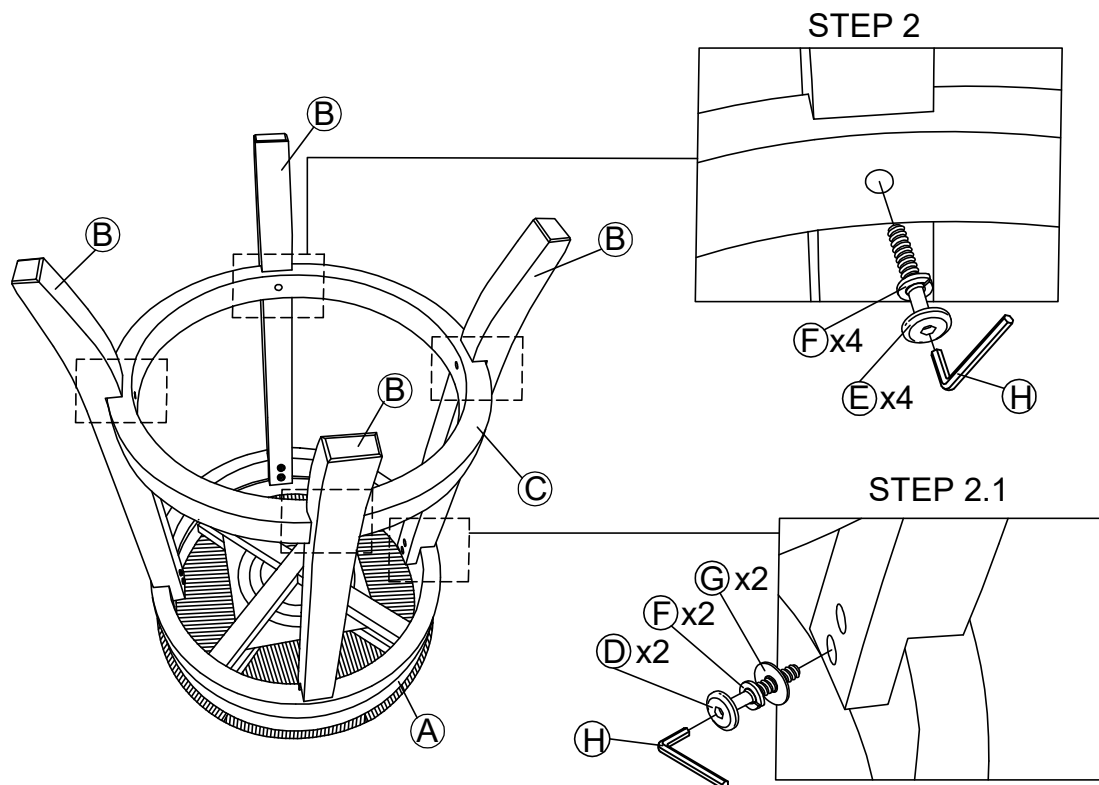

3.

Please make sure all screws are tightened 100%.

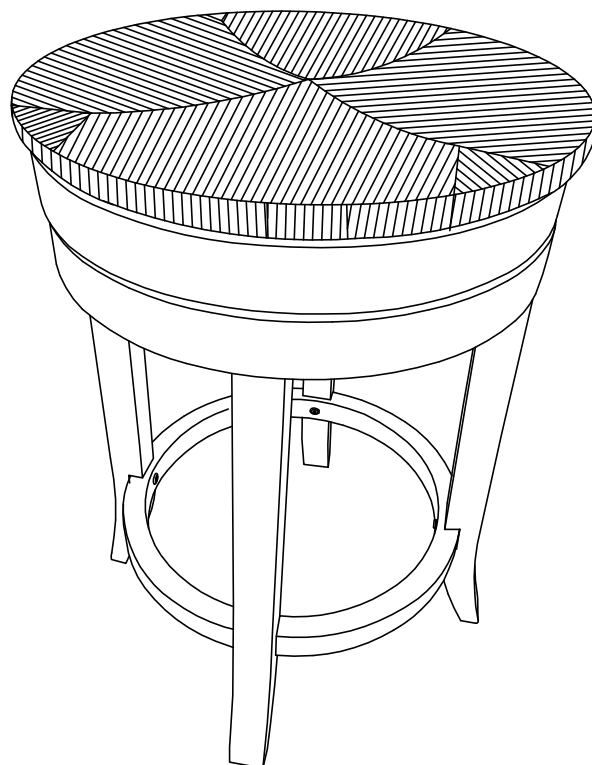

ASSEMBLY  
COMPLETED!!!