

INSTALLATION GUIDE

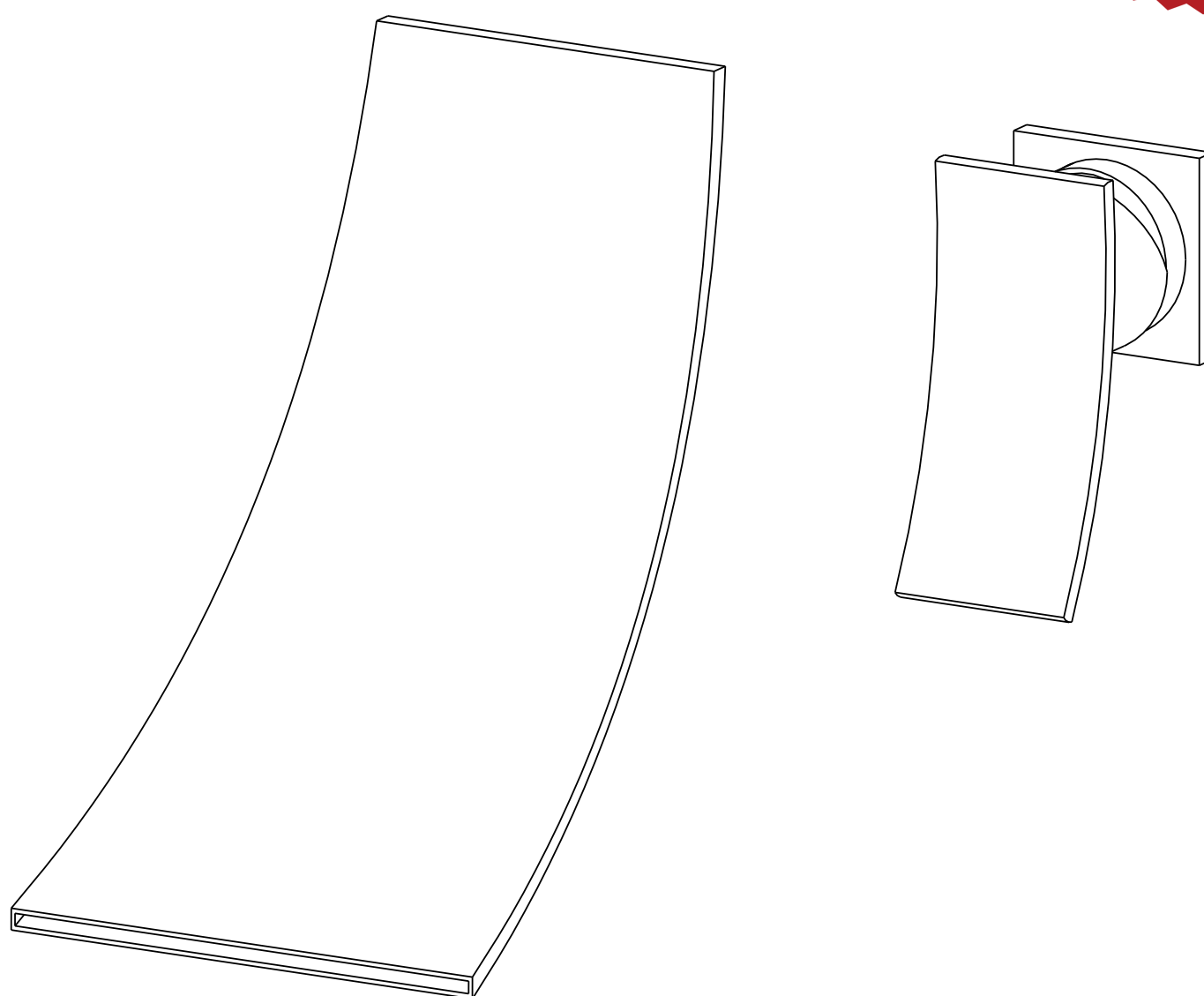

WALL MOUNTED WATERFALL VESSEL SINK FAUCET

WALL MOUNTED WATERFALL TUB FILLER

MODEL	FINISH
S1364CW	CHROME
S1364NW	BRUSHED NICKEL
S1364DW	MATTE BLACK
S1364BGW	BRUSHED GOLD

HOT LINE: +1-866-203-0866

THANK YOU

Dear Valued Customer,

Thank you for choosing SUMERAIN products. We sincerely appreciate your recent purchase and hope you are fully satisfied with your new product. At SUMERAIN, all our products are meticulously designed, engineered, and rigorously tested to ensure long-lasting, trouble-free performance under normal conditions.

Installation is simple with basic tools and our step-by-step illustrated guide. We welcome your questions or feedback and look forward to assisting you in the future. For any inquiries, please contact us at +1-866-203-0866 or email us at [support@sumerain.com](mailto:supports@sumerain.com).

Thank you again for selecting SUMERAIN. We remain dedicated to providing exceptional customer service.

Sincerely,

SUMERAIN Customer Service Department

BEFORE PROCEEDING

1. Unpack the product and ensure all components are included in the package. Keep the product in its original packaging until you are ready to install it to prevent damage.
2. Locate the water supply inlets and turn off the water supply valves, which are typically near the water meter or under the sink. If replacing an existing unit, remove the old one and thoroughly clean the mounting surface.
3. Follow all applicable local and state plumbing and building codes to ensure proper installation.
4. If you are uncertain about the installation process, we strongly recommend consulting a professional to avoid potential issues.

TOOLS RECOMMENDED

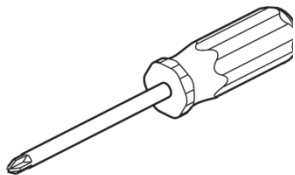

Philips Screwdriver

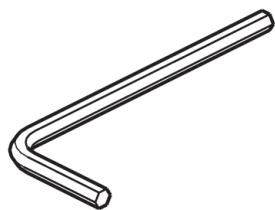

Allen Wrench

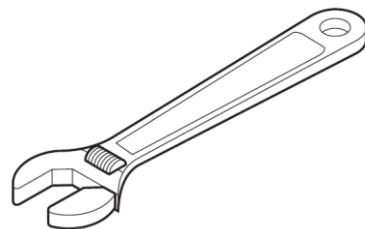

Adjustable Wrench



Channel Locks



Teflon Tape

LIMITED LIFETIME CONSUMER WARRANTY

VERSION: 140320.15.3

This product is manufactured and rigorously tested to meet the highest quality standards by HONGKONG SUMERAIN SANITARY INDUSTRY Co., Limited ("SUMERAIN"). This warranty is exclusively applicable to SUMERAIN products purchased by consumers in the United States on or after January 1, 2020. If a faucet develops leaks or drips during normal usage, SUMERAIN will provide the required faucet cartridge to the purchaser, free of charge, to restore the faucet to proper working condition. For any defects identified under normal residential use, SUMERAIN may, at its discretion, repair the product, supply replacement parts or products, or make necessary adjustments to ensure optimal functionality.

WHO IS COVERED BY THE WARRANTY

This warranty exclusively covers the original consumer purchaser, including those who purchased through online retail platforms. Customers specifically covered under the "Online Consumer Limited Lifetime Warranty & Return Policy" are also included. Please note that this warranty is non-transferable and cannot be assigned to any other individual or entity.

WHAT IS COVERED BY THE WARRANTY

This warranty applies exclusively to SUMERAIN-manufactured products purchased by the consumer. SUMERAIN warrants against defects in materials or workmanship under normal installation, use, service, and maintenance. If the product or its components are found to be defective due to faulty materials or workmanship, SUMERAIN will, at its discretion, provide free replacement parts or replace the entire product.

FINISH WARRANTY

Customers are responsible for inspecting the product for any material or finish defects within three days of receipt. Please note that surface finish defects are not covered under warranty once the fixture has been installed.

ELECTRONIC FAUCETS WARRANTY

SUMERAIN warrants its LED components, including electronic faucets, valves, controllers, and battery-powered devices, against material and manufacturing defects for one year from the date of purchase under normal use. The water flow impeller power device (LED power generation unit) is covered against manufacturing defects for three months from the date of purchase.

LENGTH OF WARRANTY

As stated in the following, any replacement or repaired parts of the product will be covered for the duration of this warranty, which SUMERAIN provides for a period of 1 year from the original date of purchase.

CIRCUMSTANCES THAT SUMERAIN WILL NOT WARRANT AND PAY FOR:

- A. Conditions, malfunctions, or damage that are not caused by defects in material or workmanship are not covered under the warranty.
- B. Conditions, malfunctions, or damage resulting from normal wear and tear, improper installation, improper maintenance, misuse, abuse, negligence, accidents, alterations, or the use of abrasive or caustic cleaning agents, "no-rinse" cleaning products, or operation contrary to the provided instructions, including issues caused by home conditions such as excessive water pressure or corrosion, are excluded from the warranty.
- C. Labor costs or other expenses related to the disconnection, deinstallation, or return of the product for warranty service, as well as the installation or reinstallation of the product, are not covered under the warranty.
- D. Accessories, connected materials, and related products (including but not limited to hand shower flexible hoses, spray flexible hoses, hand showers, and showerheads) that are not manufactured by SUMERAIN are excluded from warranty coverage.

TO OBTAIN WARRANTY PARTS OR INFORMATION

To obtain warranty parts or information, please follow these steps:

Contact your SUMERAIN retailer, call the technical service line at +1-866-203-0866, or email supports@sumerain.com.

When applying for warranty service, provide the following information:

- a. A sales receipt or proof of purchase date and platform.
- b. A detailed description of the issue.
- c. Ship the product or defective parts to the designated SUMERAIN warehouse in the United States with prepaid postage. Ensure the items are carefully packaged and insured. Once the warranty service is completed, repaired or replaced products or parts will be returned to you with prepaid postage.

If you have further questions or require additional assistance, please contact SUMERAIN using the information provided above.

EXCLUSIONS & LIMITATIONS

Under the terms of this warranty, repair, replacement, or, in limited cases, a refund of the purchase price is the sole remedy available to the purchaser. SUMERAIN assumes no obligations or liabilities and does not authorize any individual to create obligations or liabilities related to this product. SUMERAIN is not liable for any incidental, special, or consequential damages resulting from a breach of this warranty or any implied warranties, including merchantability. Please note that some states do not allow the exclusion or limitation of incidental or consequential damages, so the above limitations or exclusions may not apply to you. This warranty provides specific legal rights, and you may also have additional rights that vary by state. Before filing any legal action under the Magnuson-Moss Warranty Act, you may be required to provide SUMERAIN with a reasonable opportunity to address or resolve any non-compliance.

PRODUCT INSTRUCTIONS & QUESTIONS

Prior to installation, we strongly recommend thoroughly inspecting your SUMERAIN product for any potential damage or visible defects caused during shipping. Carefully review the included instructions for proper installation, maintenance, and care procedures. If you have any questions regarding the use, installation, performance, or warranty of your SUMERAIN product, please contact us at +1-866-203-0866 or email supports@sumerain.com. Our customer support team is available to assist with any concerns or inquiries you may have.

FUNCTIONS AND SPECIFICATIONS

Function	Bathtub Faucets
Feature	Waterfall, Wall Mounted
Theme	Modern ,Contemporary
Configuration	Vessel
Finish	Chrome/ Brushed Nickel/Matte Black/Brushed Gold
Installation Holes	Two
Number of Handles	One
Handle style	Lever
Faucet Total Height	Adjustable
Spout Reach	5-23/32"
Spout Width	4-7/8"
Spout Height	Adjustable
Installation Type	Wall Mounted
Valve Type	Ceramic Cartridge
Valve Body Material	Brass
Spout Material	304 Stainless Steel
Handle Material	Metal
Net Weight	3.95 lbs
Gross Weight	4.72 lbs
Working Water Press	20~100PSI
Max Flow Rate	9.06GPM@100PSI
Flow Rate	7.03GPM@60 PSI
Packing Box Size	9.0"x7-1/4" x5-1/2"

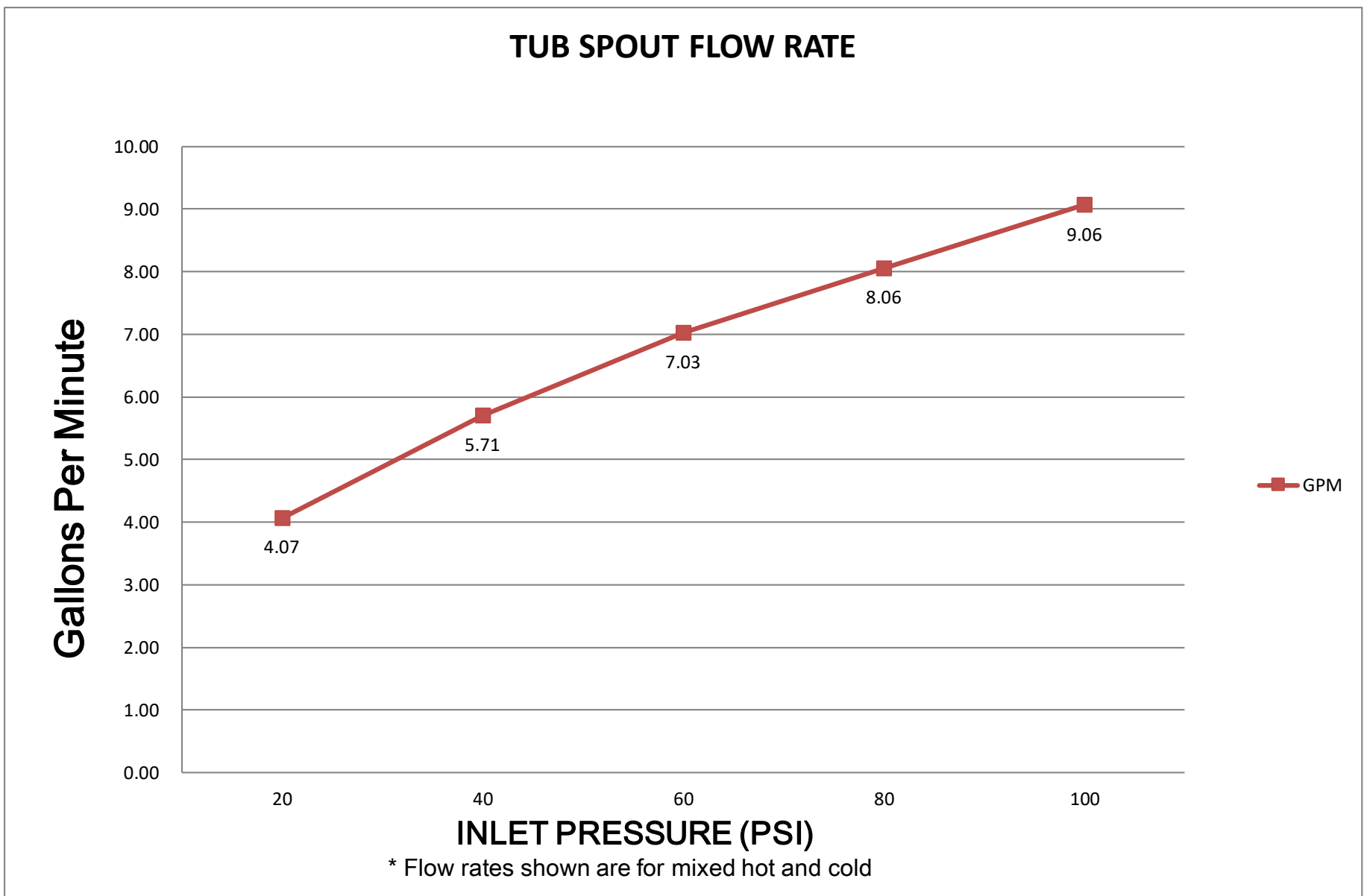

DIMENSION

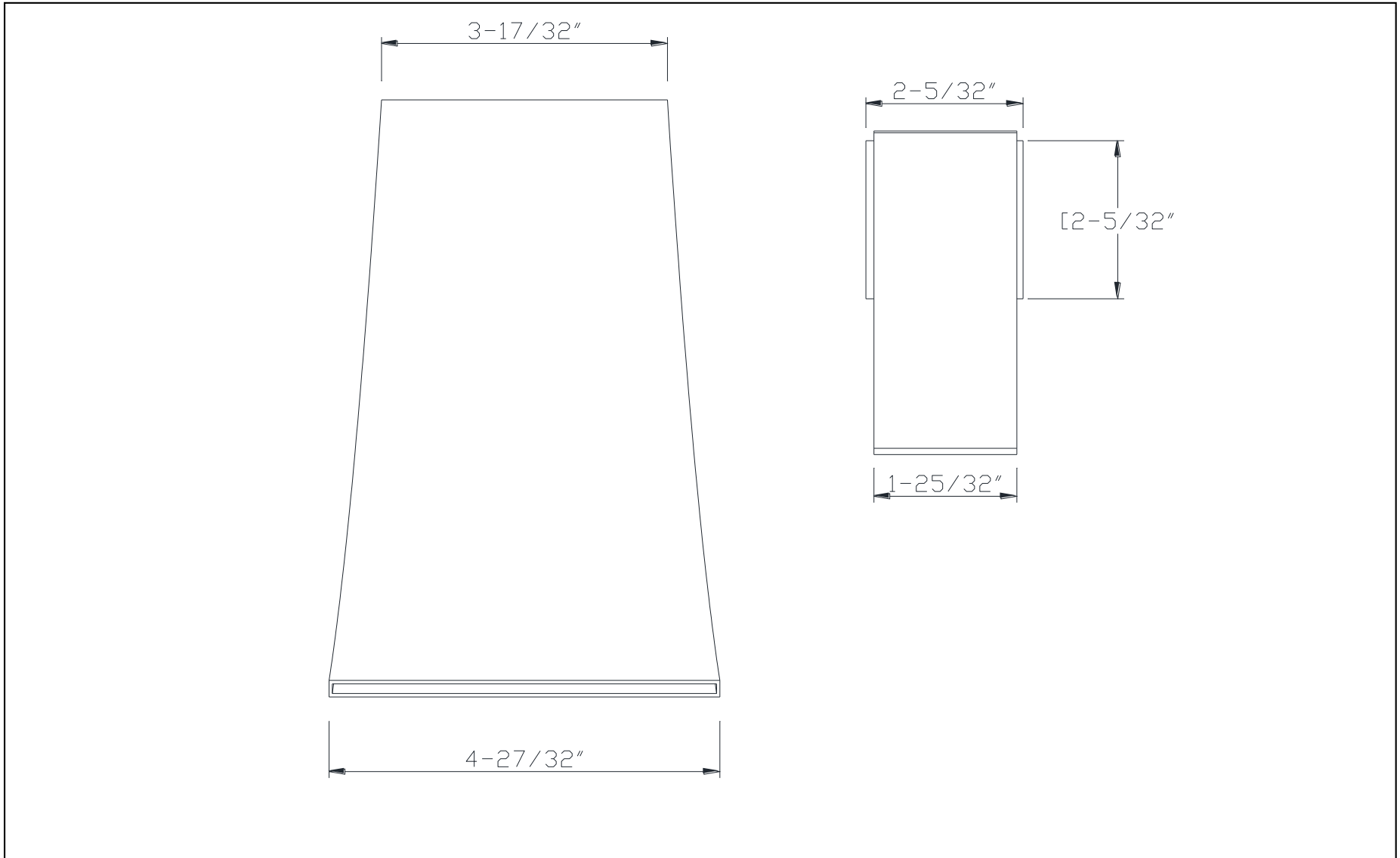

FRONT VIEW OF FAUCET

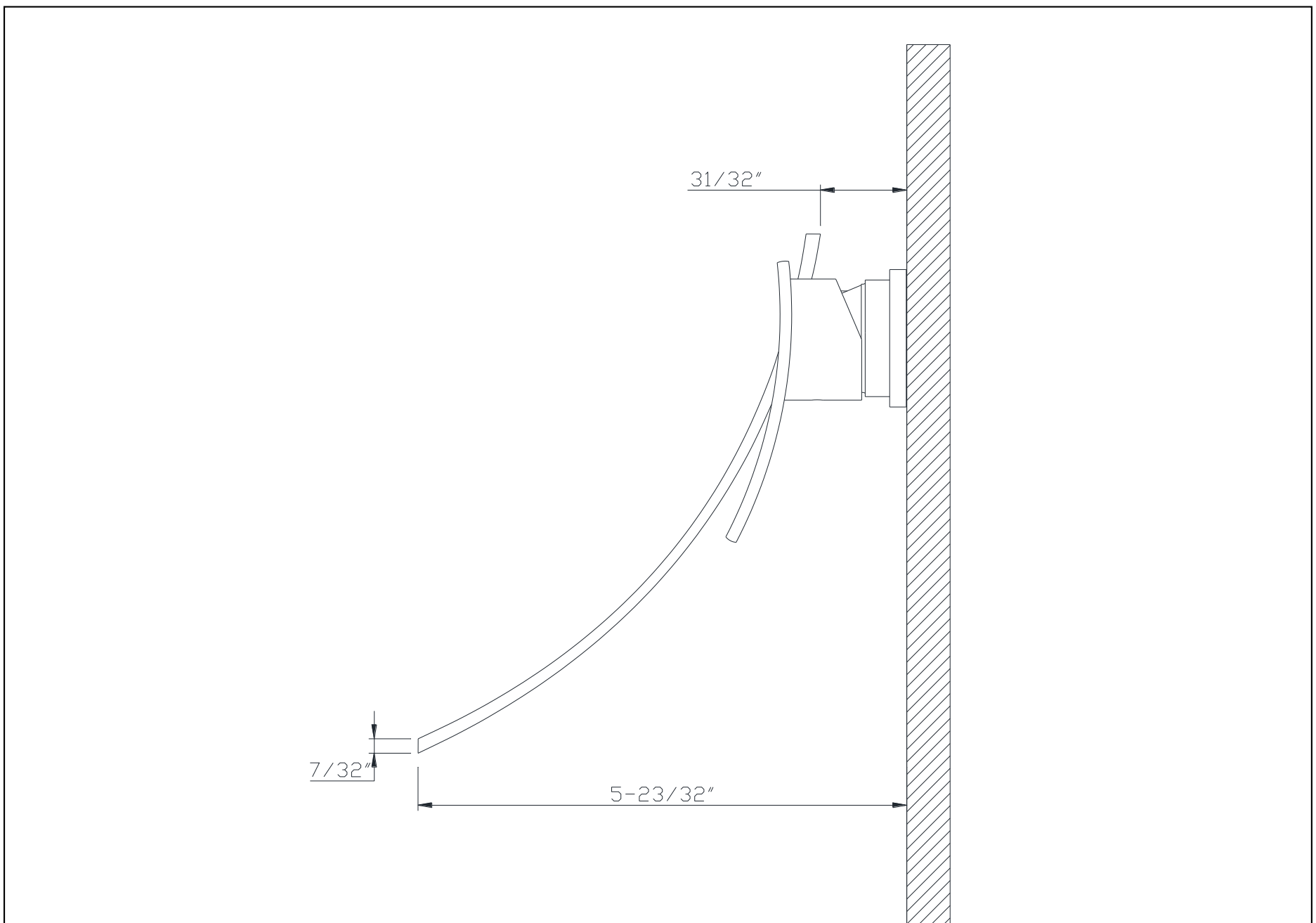

RIGHT SIDE VIEW OF F

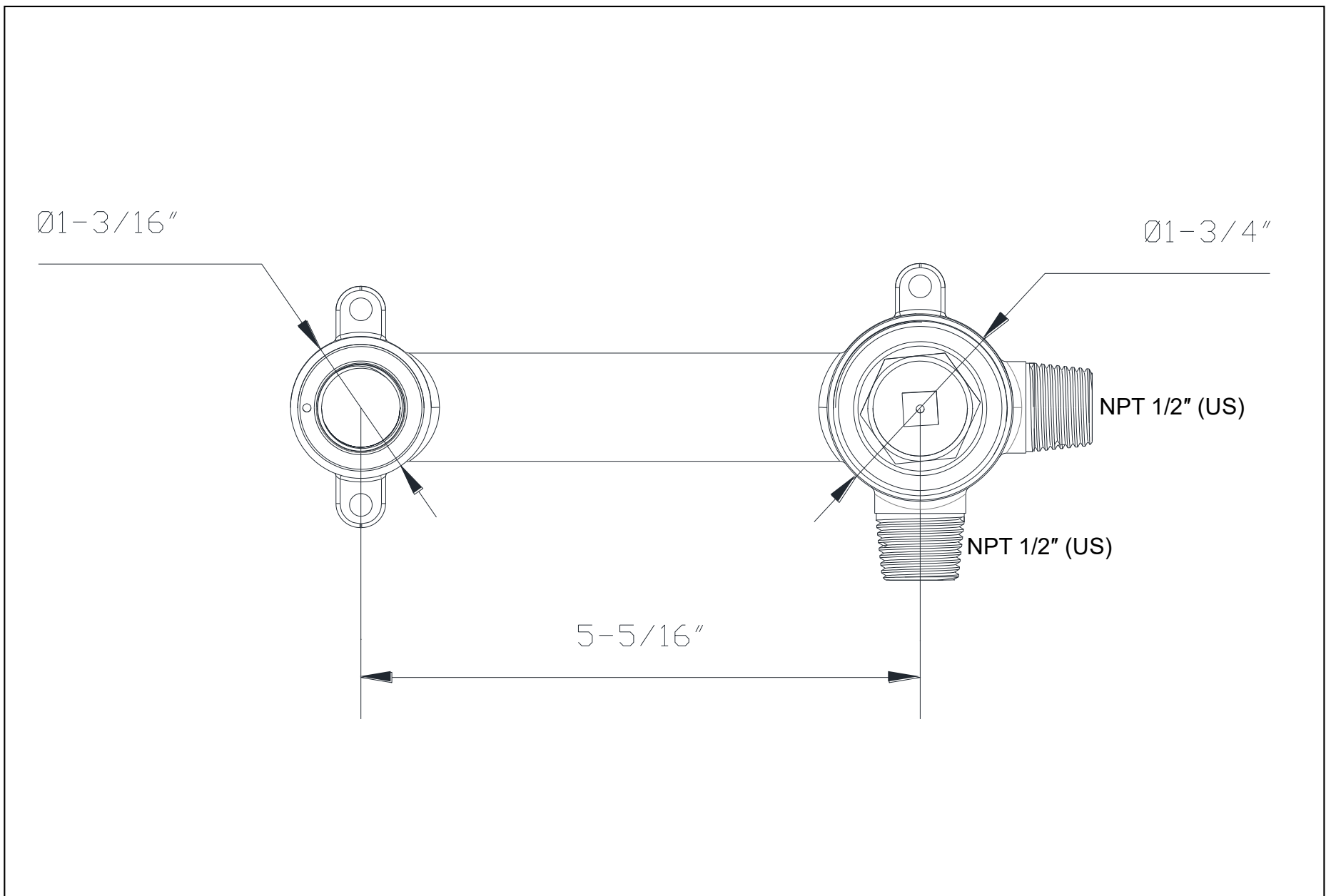

FRONT VIEW OF ROUGH IN VALVE

INSTALLATION STEPS

1. BEFORE PROCEEDING



WARNING: Before beginning any installation or operation, read all instructions carefully. If you are unsure about installing this product, consult a licensed professional. This product must be installed in compliance with all applicable local and state plumbing and building codes. Professional assistance is strongly recommended

2. SHUT OFF WATER SUPPLY

Locate the water supply inlets and turn off the corresponding water supply valves, typically located under the sink or near the water meter. If replacing an existing unit, remove the old unit and thoroughly clean the mounting surface to ensure proper installation

3. CHECKING THE CONTENTS OF THE BOX

Upon opening the box, verify that all the listed components are included.

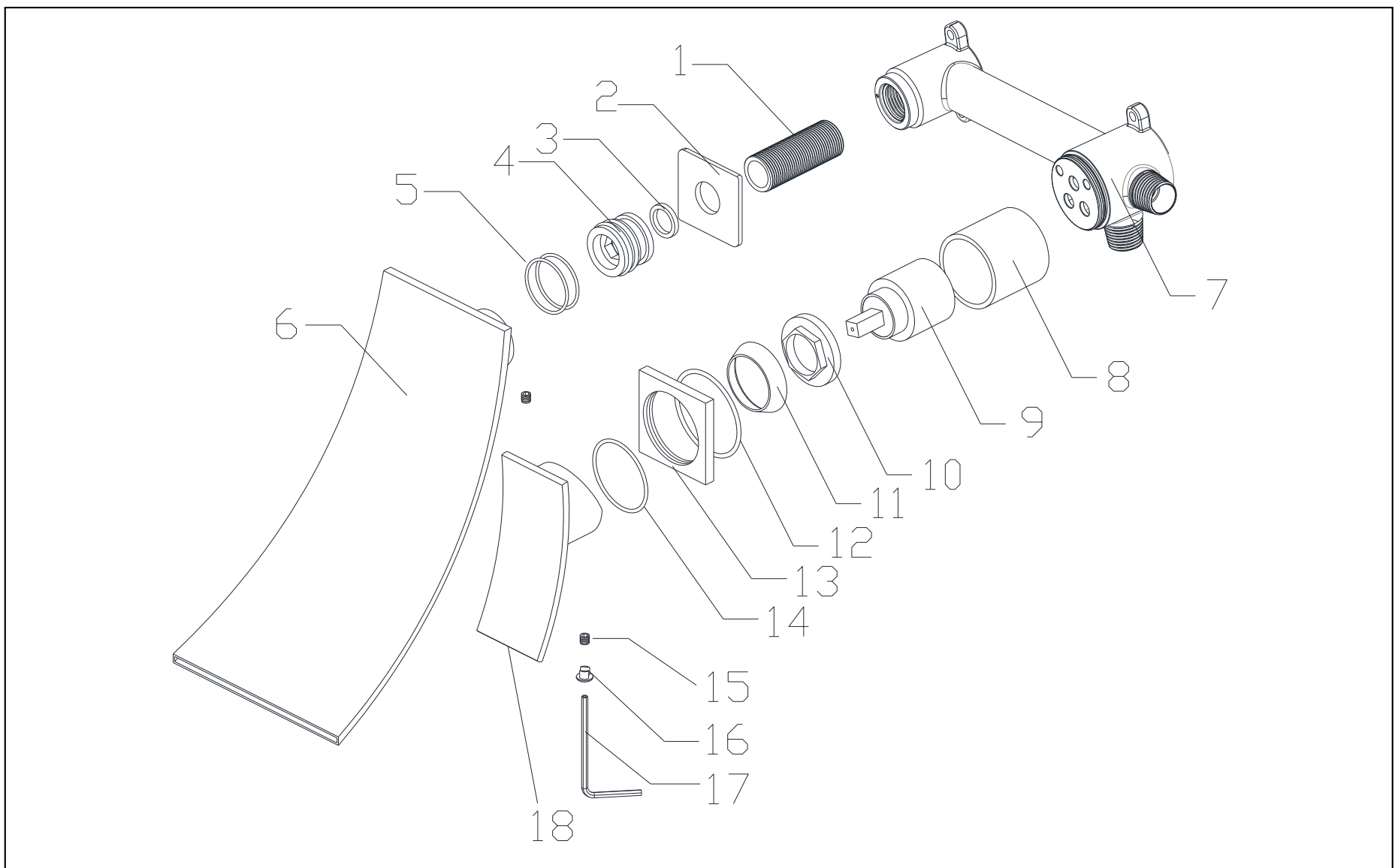

NO	ITEM NAME	MATERIAL	QTY	PART NO.	NO	ITEM NAME	MATERIAL	QTY	PART NO.
1	Spout Shank	HPB59-1	1	PCN12480XX	10	Bonnet	HPB59-1	1	PSC37125XX
2	Spout Flange	Zn Alloy No.3	1	PFC00003XX	11	Bonnet Cap	SUS304	1	PFC37125XX
3	Rubber Washer	NBR	1	PRW18020XX	12	O-Ring	NBR	1	POR50020XX
4	Spout Nipple	HPB59-1	1	PCN21290XX	13	Escutcheon	SUS304	1	PFC13640XX
5	O-Ring	NBR	2	POR28020XX	14	O-Ring	NBR	1	POR46020XX
6	Spout	SUS304	1	PSP13640XX	15	Set Screw	SUS304	2	PSC05050XX
7	Rough-in Valve	HPB59-1	1	PVB13642PB	16	Screw Cover	ABS	1	PSA00002XX
8	Sleeve	HPB59-1	1	PSL00001XX	17	Allen Wrench 2.5mm	Fe45#	1	PSA00003XX
9	35# Cartridge	ASSEMBLE	1	PCT35004XX	18	Handle (Lever)	Zn Alloy No.3	1	PHD13640XX

If any of these items are missing, please contact SUMERAIN consumer service by email to: supports@sumerain.com.

4. VALVE TRIM INSTALLATION

4.1 Construct a rough-in valve mounting bracket, typically made of wood, to securely hold the valve during installation. Ensure that the mounting surface of the bracket is recessed between 2" (minimum) and 2-1/2" (maximum) from the finished wall surface.

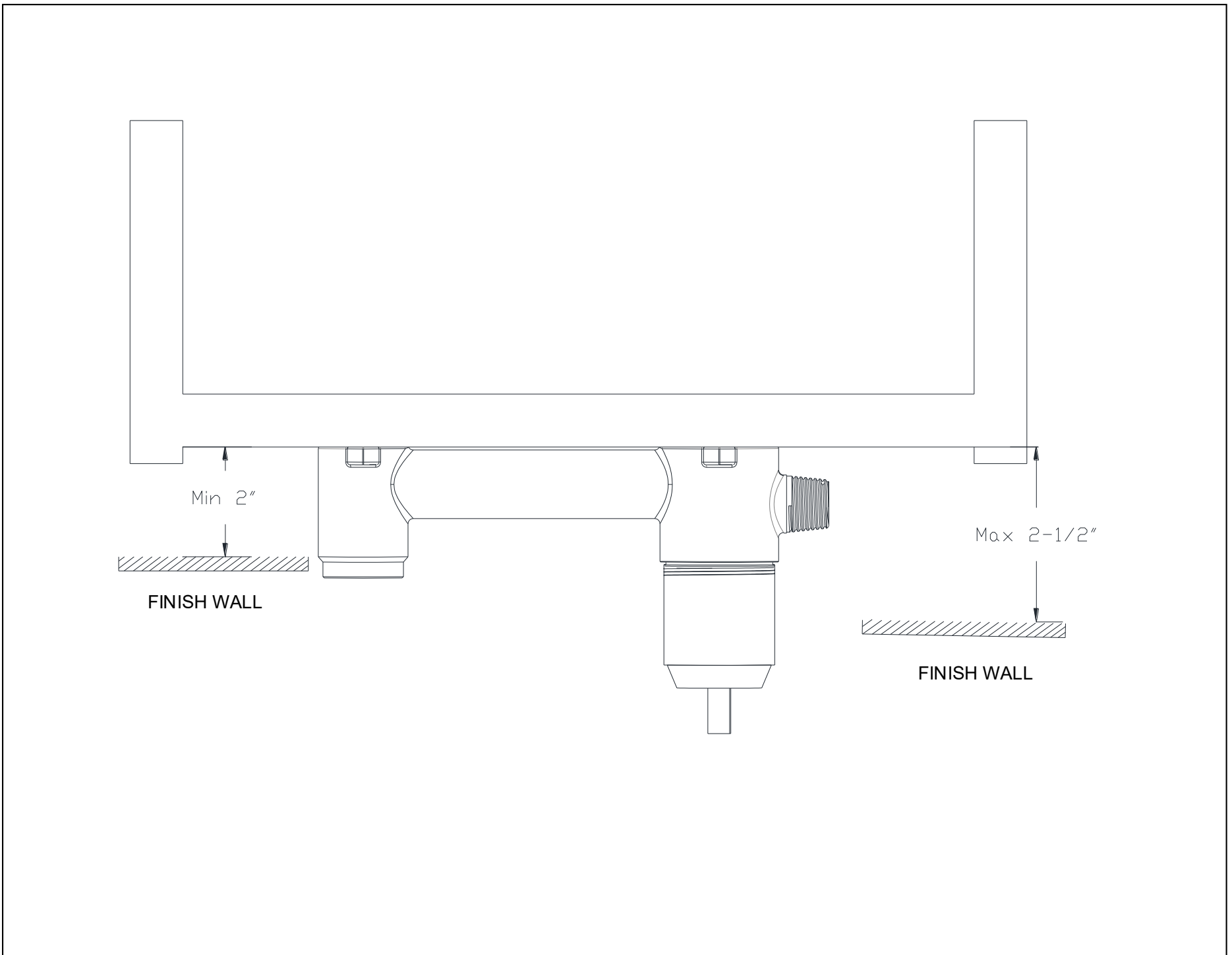
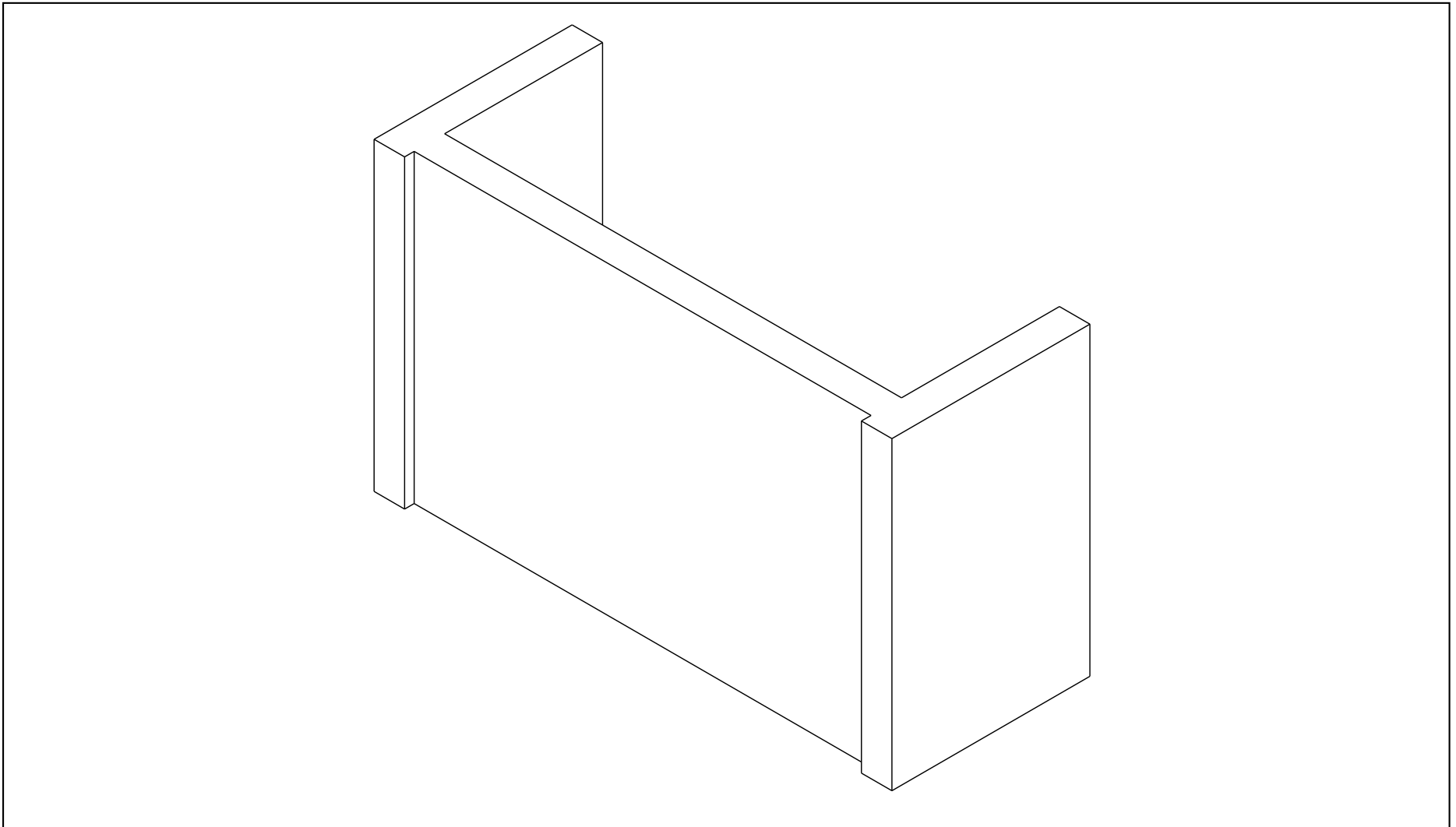

4.2 Secure the rough-in valve to the mounting bracket using screws (not included).

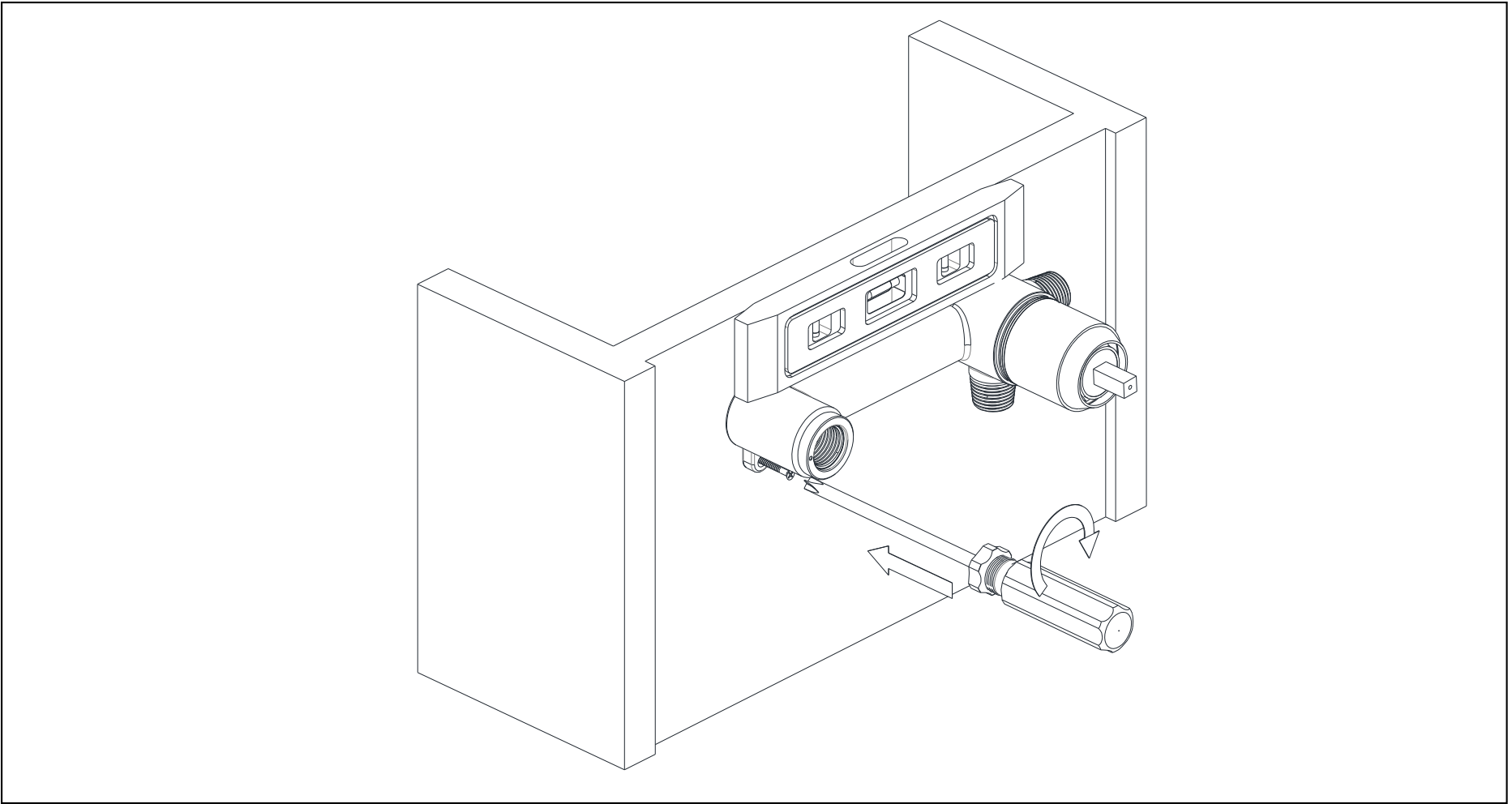

4.3 Turn on the shut-off valves to flush the hot and cold water supply lines before connecting them to the valve trim. Allow water to run for 3-5 minutes to remove any dirt and debris. After flushing, turn off the water supply again.

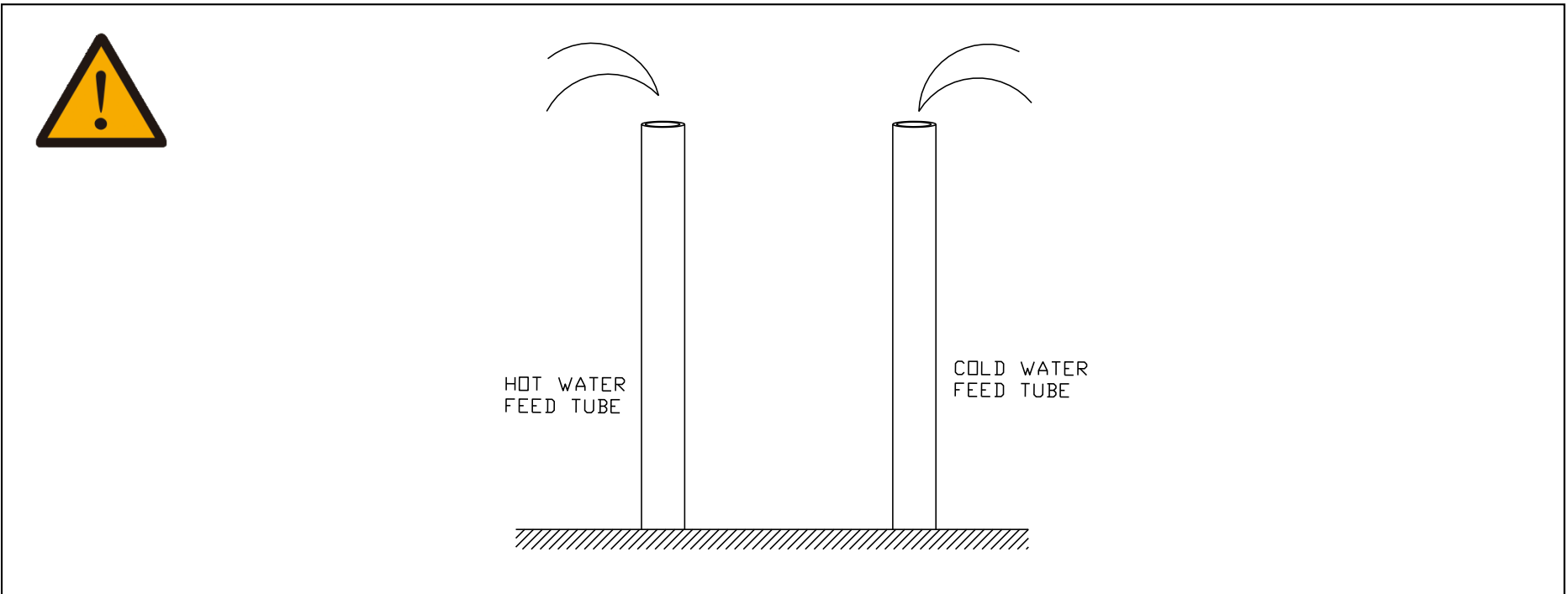

4.4 Apply Teflon tape to the threads of the tube inlet, then connect it to the valve trim using the elbow fitting.

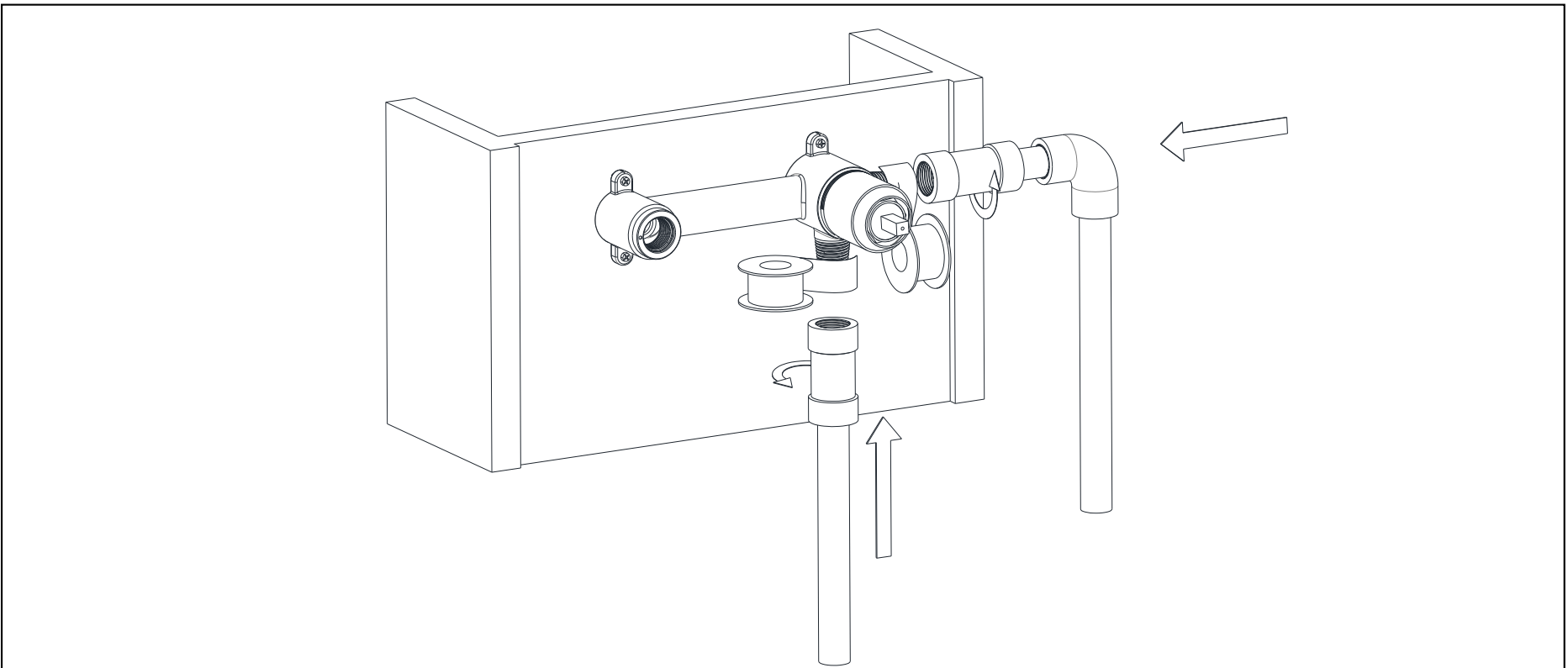

4.5 Plumbing Pressure Testing and Leak Testing.

(a.) Water Pressure Testing Standards

Test Pressure:

- The test pressure shall be 1.5 times the working pressure of the piping system, but not less than 60 PSI (pounds per square inch).
- If the design working pressure of the piping system is less than 60 PSI, the test pressure shall be 60 PSI.
- Recommended test pressure: 100 PSI to 120 PSI (approximately 6.9 to 8.2 bar).

Test Duration:

- The test duration is typically 15 minutes.
- During the test, the pressure should remain stable with no significant drop.

Testing Method:

1. Seal the piping system, ensuring all openings (e.g., faucets, valves) are closed.
2. Use a manual pump or pressure testing equipment to pressurize the system to the specified test pressure.
3. Observe the pressure gauge to ensure the pressure remains stable during the test.
4. Inspect all connections, joints, and faucets for any signs of leakage.

Pass Criteria:

- If the pressure remains stable with no significant drop and no leakage is observed during the test, the piping system passes the test.
- If the pressure drops or leakage is detected, repair the issue and retest.

Precautions:



- Safety: The test pressure should not exceed the rated pressure of the pipes and fittings to avoid damage.
- Record: Record the test pressure, duration, and results for future inspection or maintenance purposes.

(b.) Leak Testing: After completing the plumbing pressure test, turn on the hot and cold water supply again and check all connections for leaks. If no leaks are detected, shut off the hot and cold water supply and reinstall the plaster guard covers.

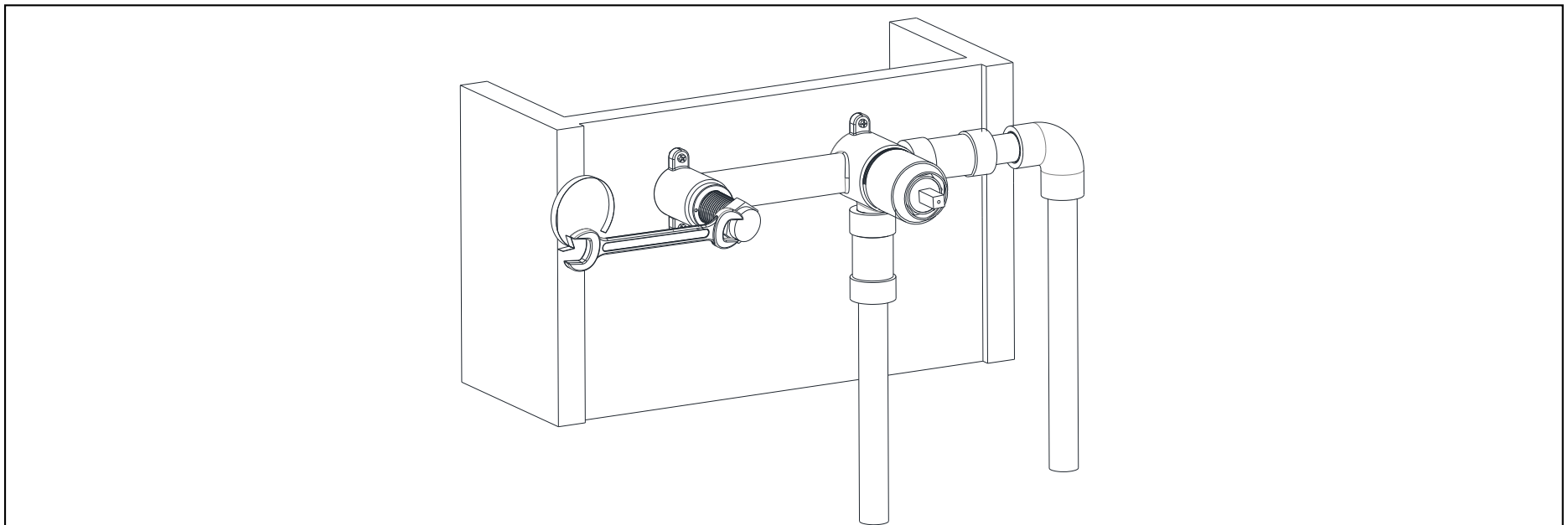

Precautions:



- Record: Record the test pressure, duration, and results for future inspection or maintenance purposes.

4.6 Install the finished wall.

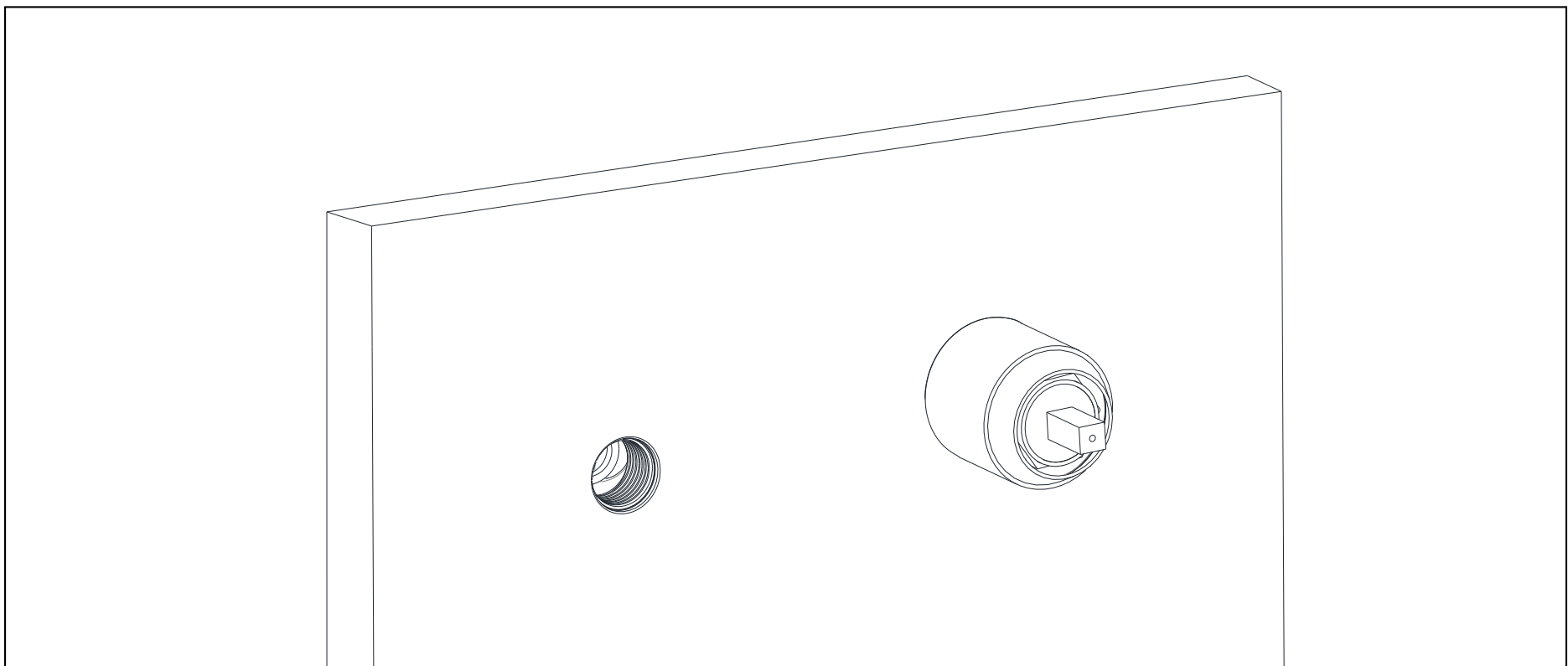

4.7 Install the spout adapter.

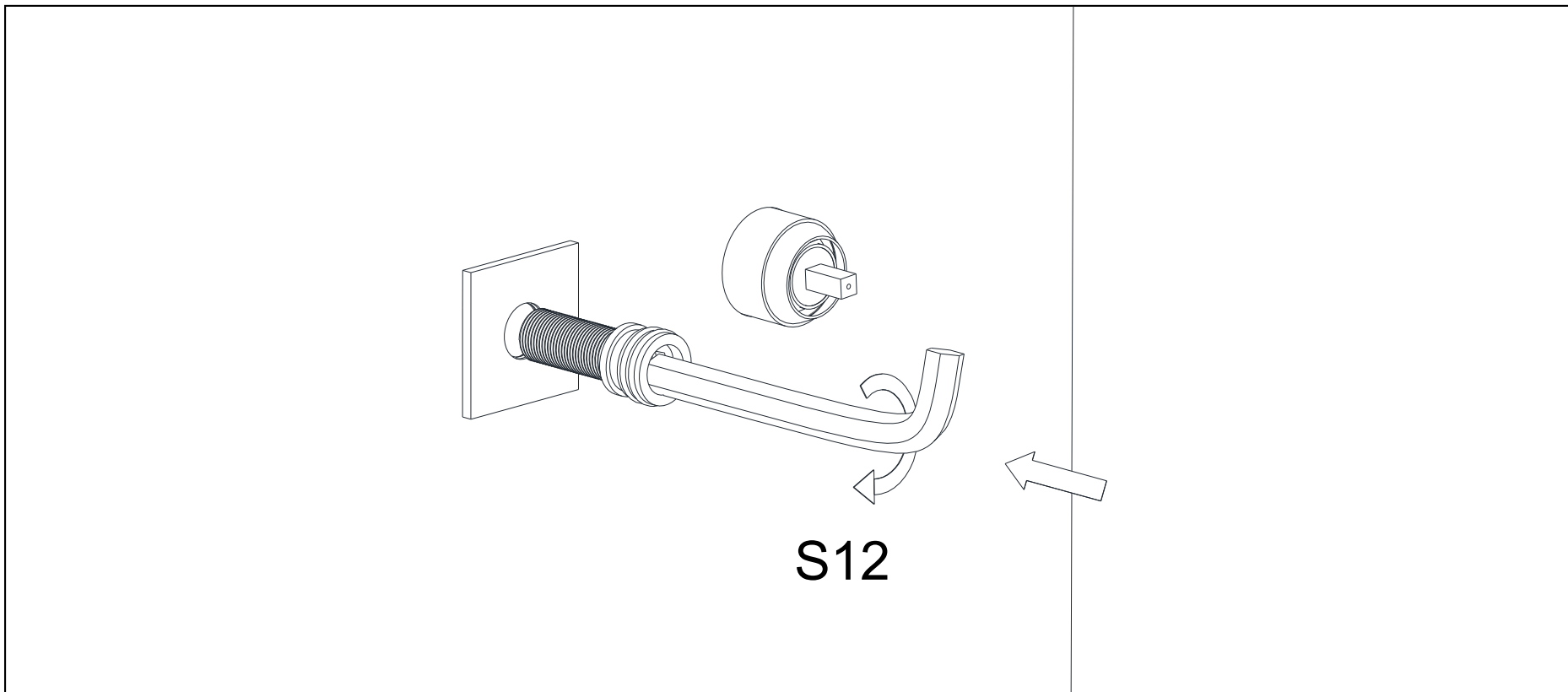

4.8 Attach the spout to the spout adapter.

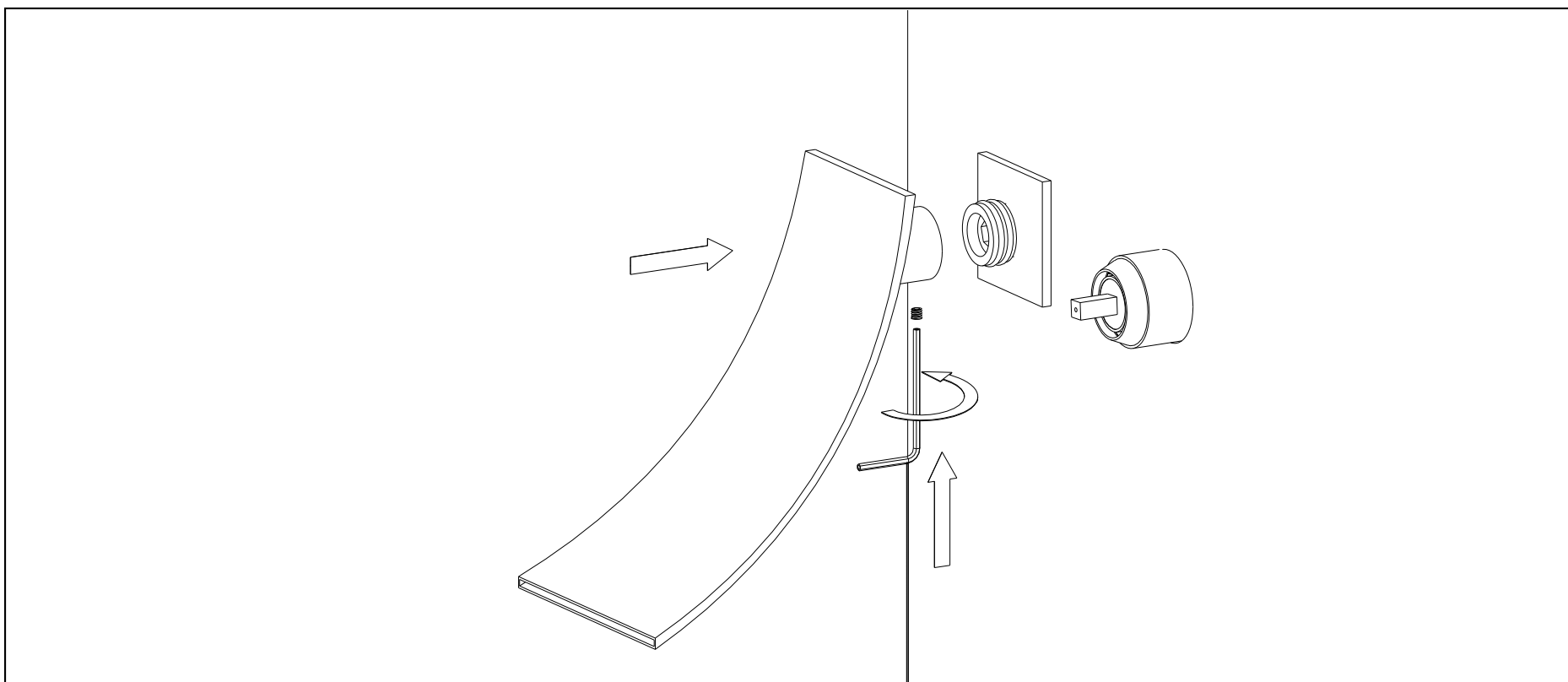

4.9 Slide the escutcheon over the cartridge sleeve and secure it to the finished wall.

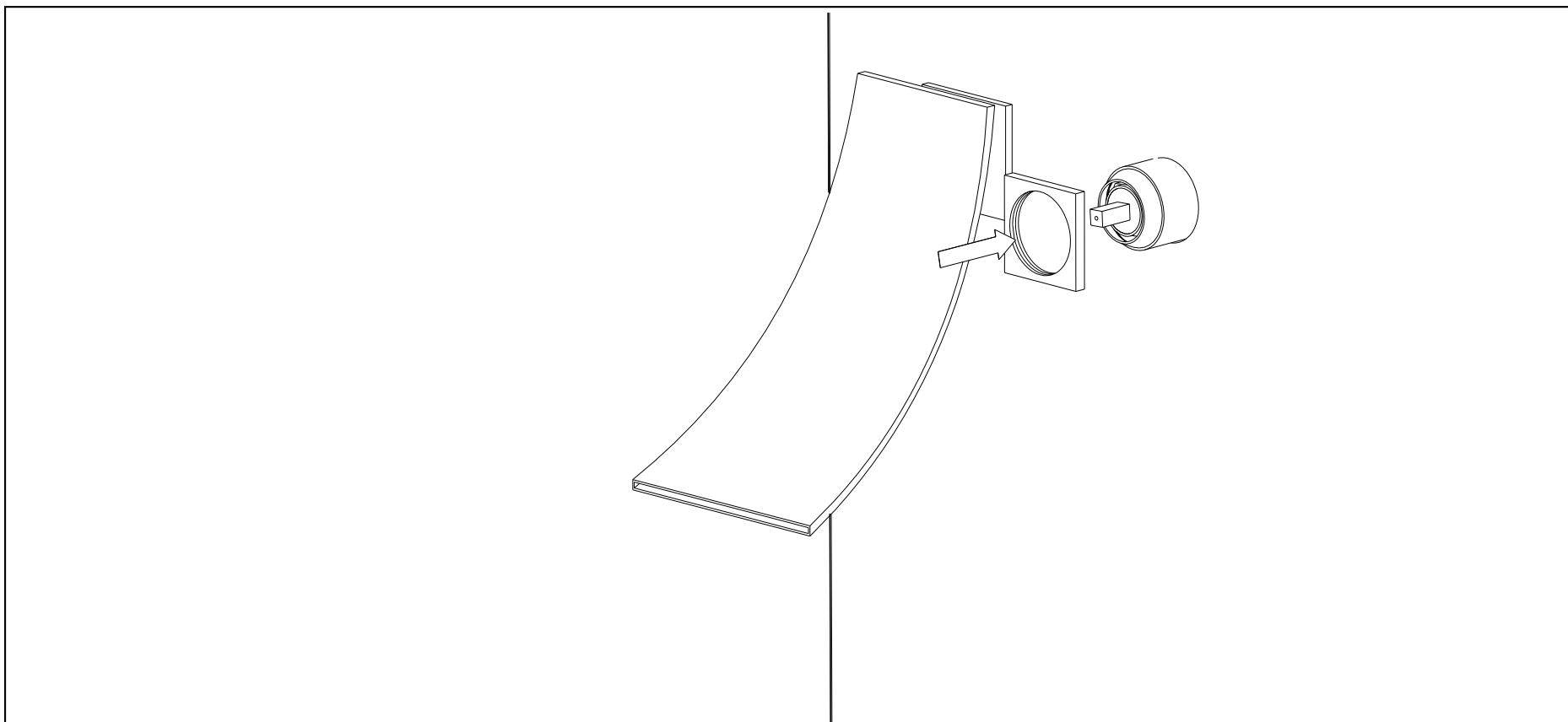

4.10 Place the handle onto the valve stem and tighten the set screw using the provided Allen wrench. Do not overtighten to avoid damage.

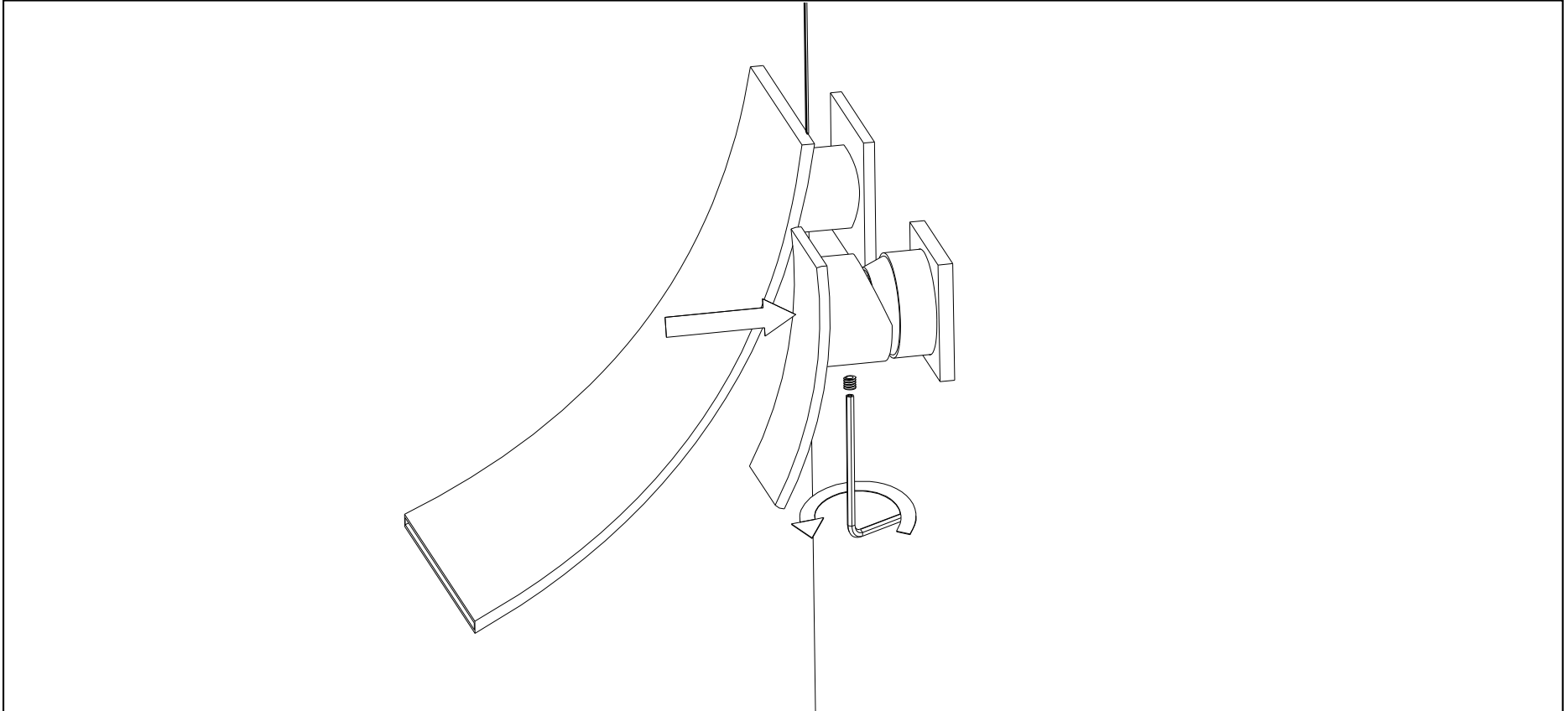

5. Attach the handle button (hot/cold indicator) onto the handle to conceal the set screw.

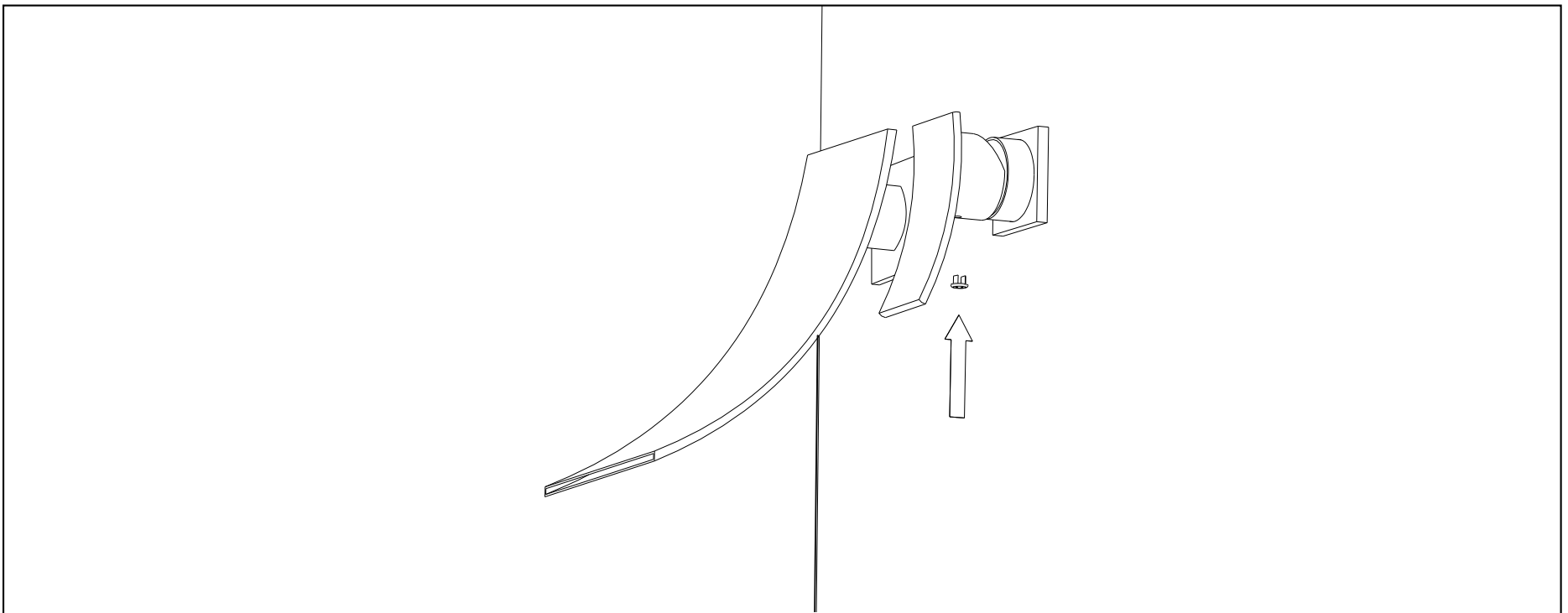

ASSEMBLY COMPLETE

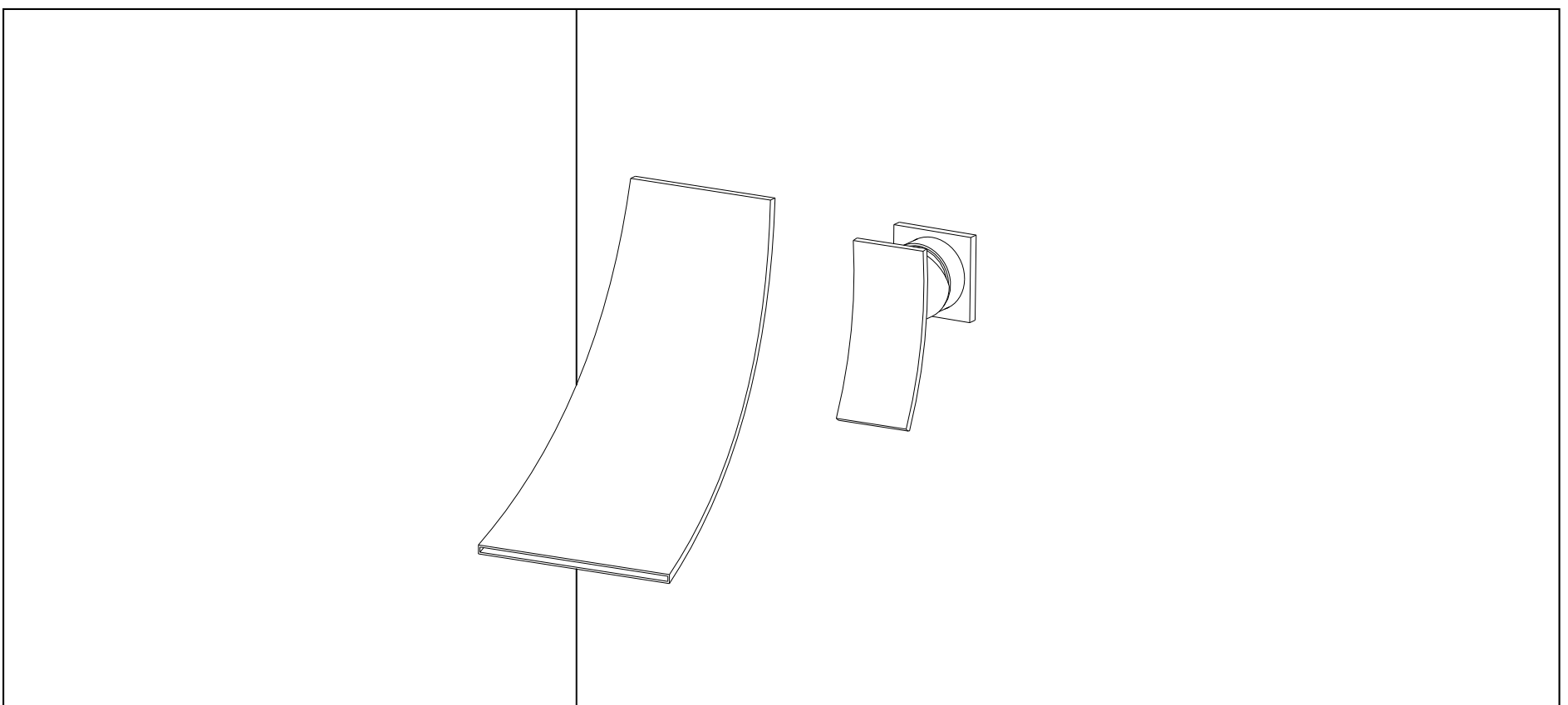

6. INSPECTION

6.1 Turn on the hot and cold water supplies and check all connections to ensure there are no leaks

7. FUNCTION INSPECTION

7.1 Turn on the handle to allow water to flow from the spout, and turn off the handle to stop the water flow.

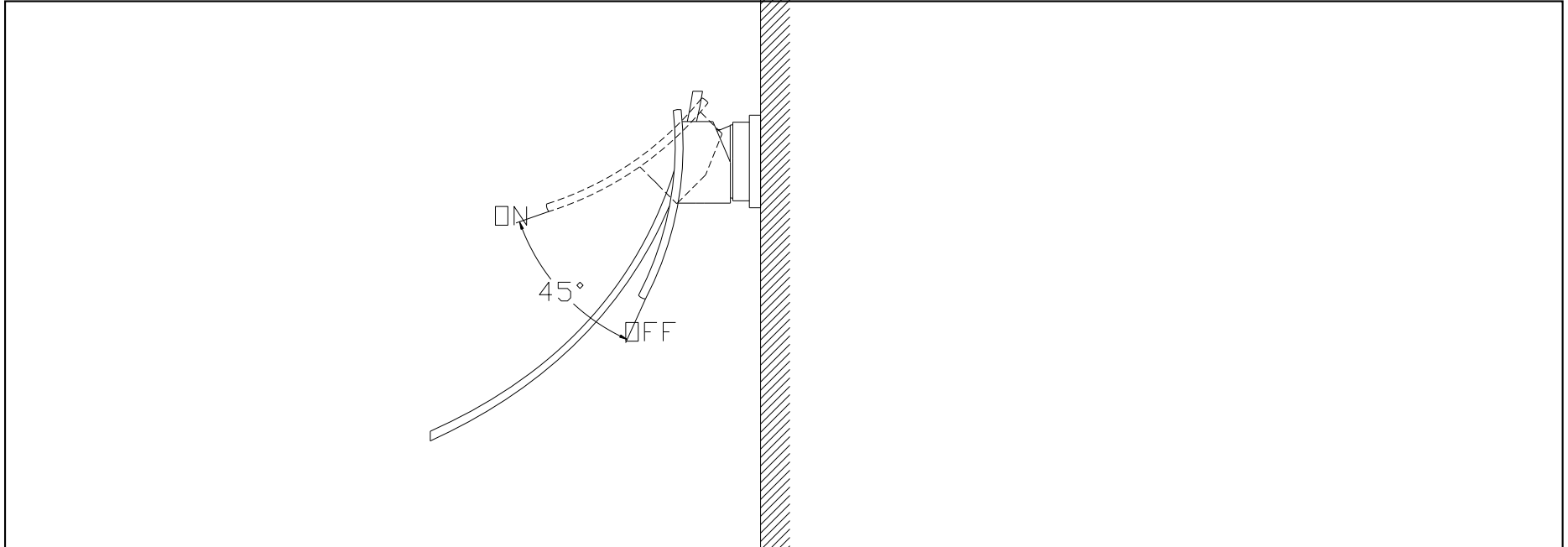

7.2 Turn the handle to the right to activate cold water. Conversely, turn the handle to the left to activate hot water.

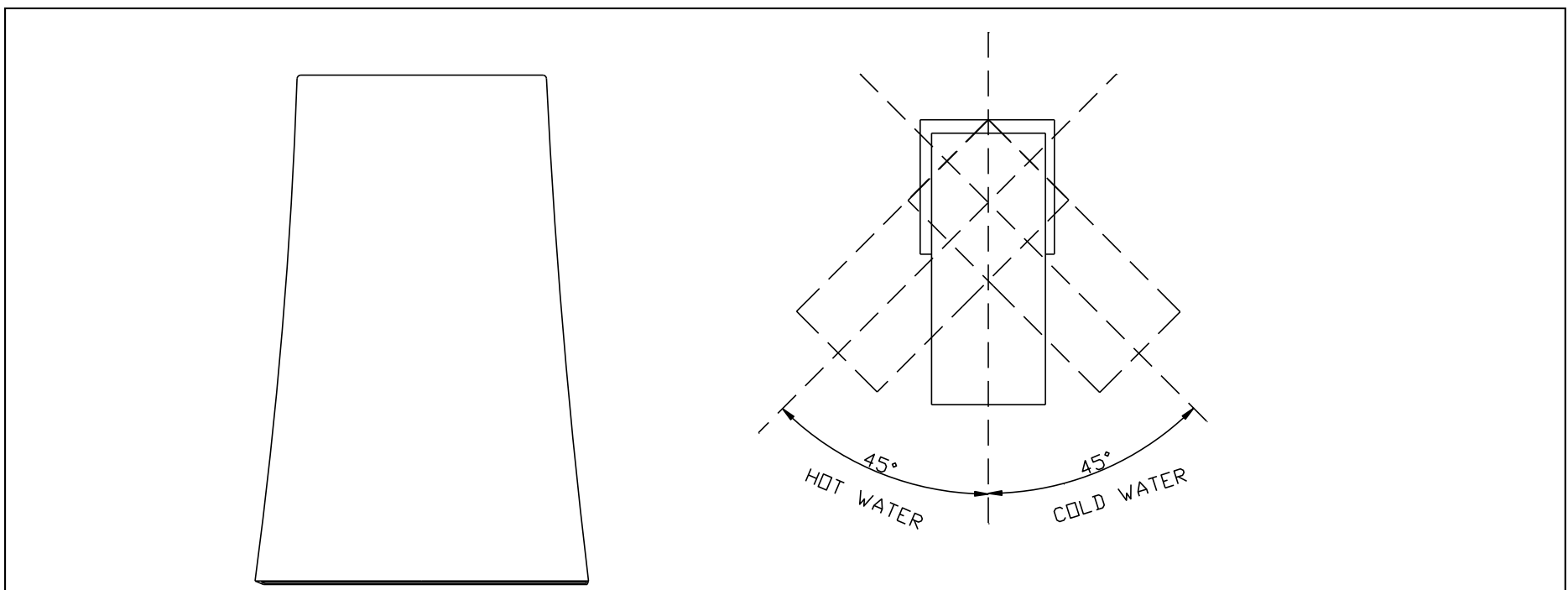

INSTALLATION FINISHED

TROUBLESHOOTING

Symptom	Solution
If the faucet leaks from the handle	A. Tighten the packing nut. B. Replace the O-ring or packing if necessary.
The water pressure is insufficient for optimal operation	A. Ensure that the water supply valves under the sink are fully open. B. Clean or replace the aerator to improve water flow. C. Inspect the plumbing system for potential water pressure issues
The spout disperses water irregularly, indicating a potential issue with the aerator or water pressure.	A. Clean or replace the aerator to ensure optimal water flow. B. Replace the aerator washer to prevent leaks or irregular water flow.
Water is leaking from the faucet connections beneath the sink	A. Verify that the water supply connections to the faucet are secure and properly tightened. B. Examine the water supply lines or hoses for any signs of leaks or damage.
The handle is loose and requires adjustment.	A. Remove the cap and securely tighten the screw to ensure proper fit. B. Identify the hex set screw and tighten it using the supplied hex wrench. B. Detach the handle and inspect the stem for stripped or damaged teeth. C. Remove the handle and check for stripped teeth on the stem.

CLEANING RECOMMENDATION FOR SUMERAIN PRODUCTS

Modern lavatory faucets, kitchen faucets, and showers are crafted from a variety of materials to meet the market's demands for both design and functionality. To prevent damage and reduce the likelihood of returns, it is essential to follow the recommended cleaning guidelines.

Cleaning Materials for faucets & showers

When cleaning faucets and showers, it is essential to follow these professional guidelines:

- Use acidic cleaning agents specifically formulated for lime removal.
- Only use cleaning products designed for this purpose to avoid damage.
- Do not use cleaning agents containing hydrochloric, formic, phosphoric, or acetic acid, as these can cause severe damage to the surface.
- Never mix different cleaning agents, as this may lead to harmful chemical reactions.
- Avoid abrasive cleaning products or tools, such as unsuitable cleaning powders, rough sponge pads, or microfiber cloths that could harm the finish.

Cleaning instructions for faucets & showers

Please follow the cleaning material manufacturer's instructions carefully. Additionally, observe the following guidelines to maintain your faucets and showers:

- Clean faucets and showers regularly as needed to preserve their optimal function and appearance.
- Use the recommended amount of cleaning product and apply it for the specified duration. Avoid leaving the cleaner on the surface longer than necessary to prevent potential damage.
- Regular cleaning helps prevent calcification. For scale deposits on faucet surfaces or spouts, use a commercial descaler such as Lime-Away® or CLR®.
- If rust forms due to hard water, gently remove it by rubbing the affected area with aluminum foil soaked in water until smooth. Then, apply a small amount of chrome polish or an appropriate product like automotive wax (e.g., Meguiar's® or Turtle Wax®) to restore the finish.
- Solid stainless steel faucets and spouts, especially waterfall designs, usually lack a protective coating. While stainless steel resists tarnishing, it can oxidize over time. Keep stainless steel fixtures clean and dry, and use a stainless steel-specific cleaner such as Weiman® or CLR® for proper maintenance.
- When using spray cleaners, apply the product to a soft cloth or sponge first instead of spraying it directly onto the faucet. This prevents water droplets from entering the faucet openings and causing damage.
- After cleaning, rinse all surfaces thoroughly with clean water to remove any cleaner residue.

Important

Residues from liquid soap, shampoo, and shower gel can contribute to surface damage over time. To prevent this, thoroughly rinse these substances off with clean water after each use



Note: If the surface is already damaged, using cleaning materials may worsen the damage.

Components with damaged surfaces must be replaced to prevent potential injury.

Please note that any damage caused by improper use, maintenance, or cleaning is not covered under the warranty.



SUMERAIN INTERNATIONAL GROUP INC

Address: 1226 NORTH KING ST NUM 522
WILMINGTON, DE 19801
United States

Tel: +1(866)203-0866

Web: <http://www.sumerain.com>

E-mail: supports@sumerain.us

HONGKONG SUMERAIN SANITARY INDUSTRY CO., LIMITED

Address: FLAT/RM 3B 3/F BANK TOWER
NOS.351&353 KING'S ROAD
NORTH POINT
HK

Tel: +86-750-2731579

E-mail: supports@sumerain.com

SUMERAIN EUROPE SUPPORT

Address: Flottwellstr.15
10785 Berlin,
Deutschland

Tel: +49 (0)30/23975898

E-mail: de@sumerain.com