

INSTALLATION & ASSEMBLY

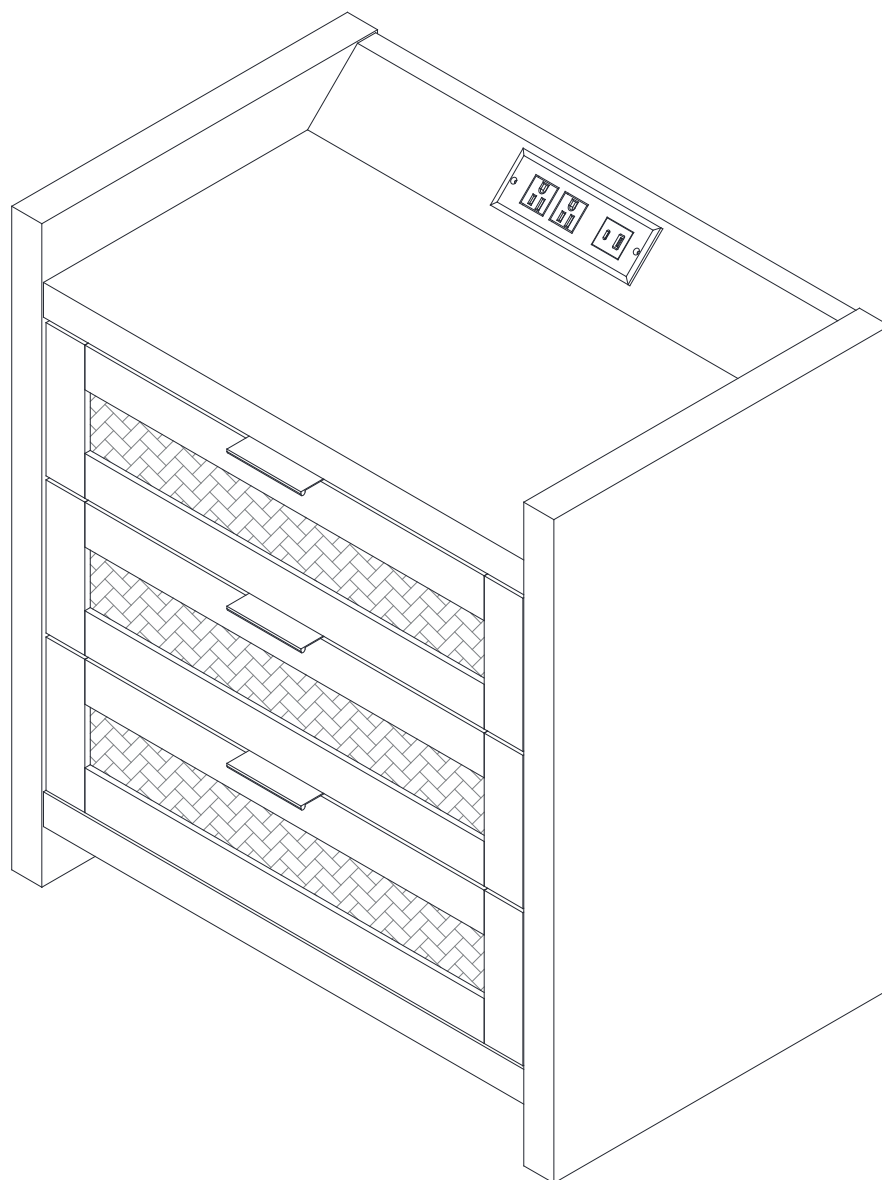

Made In China

Assembly Instructions

Before beginning the assembly process, please read and save these instructions for reference. Following these guidelines will ensure a smooth and successful assembly of your product.

1. Part Identification:

Carefully separate and identify all the parts included in your package. Confirm that you have all the components listed in the instruction manual. This step will help you avoid any missing or misplaced parts during assembly.

2. Work Surface:

To prevent any scratches or damage to the product, assemble it on a soft mat or a similar protective surface. This will provide a cushioned area for the components and protect the surfaces from unwanted marks.

3. Step-by-Step Assembly:

Follow the assembly instructions provided, proceeding one step at a time. Take care to understand each step properly before proceeding to the next one. This sequential approach ensures that the assembly is done correctly and minimizes the chance of errors.

4. Proper Screw Seating:

When attaching screws and nuts, it is essential not to fully tighten them until all screws are correctly seated. By partially tightening each screw and nut initially, you can ensure that they are aligned properly and fit securely before final tightening.

5. Avoid Over-Tightening:

While each screw and nut should be tightened correctly, it is crucial not to over-tighten them. Over-tightening can cause damage to the product or compromise its structural integrity. Use the appropriate amount of force to secure the components without excessive tightening.

Parts List

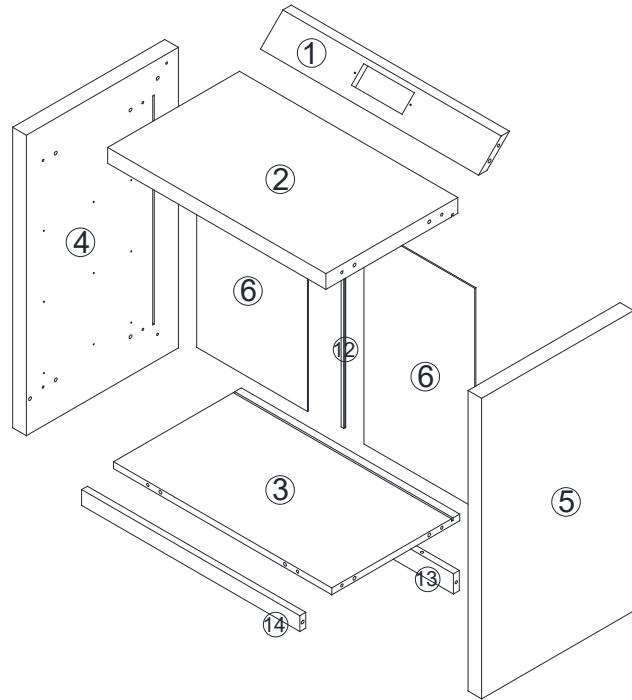
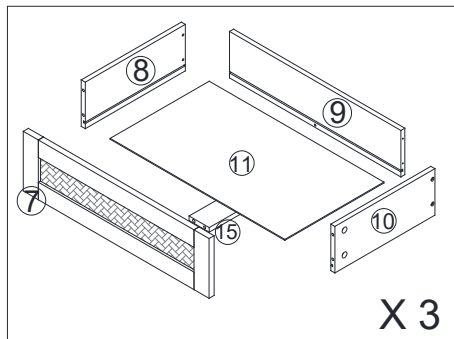

Hardware List

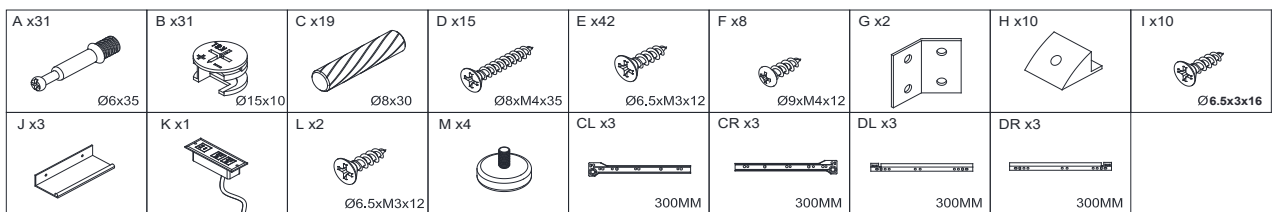



Code	Description	Quantity
A	Cam bolt	31+2
B	Cam lock	31+2
C	Wooden dowel	19+2
D	M4x35MM Screw	15+2
E	M3x12MM Screw	42+2
F	M4x12MM Screw	8+2
G	Iron sheet	2
H	Back clip	10+2

Code	Description	Quantity
I	M3x16MM Screw	10+2
J	Handle	3
K	Furniture Power Distribution Unit	1
L	M3x12MM Screw	2+2
M	Adjusting the footrest	4
CL	300mm Drawer runner set	3
CR	300mm Drawer runner set	3
DL	300mm Drawer runner set	3
DR	300mm Drawer runner set	3

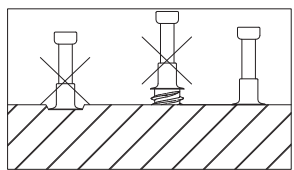
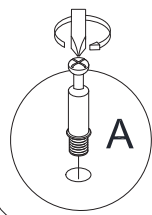
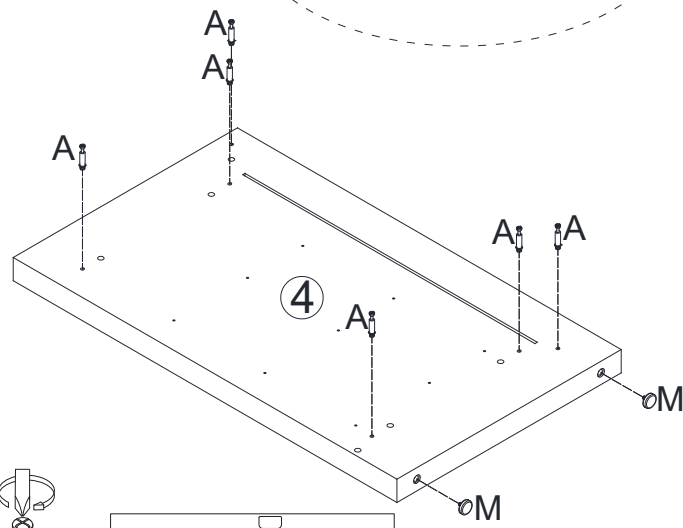
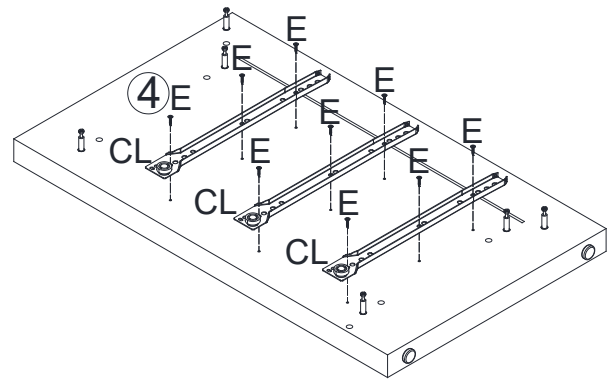
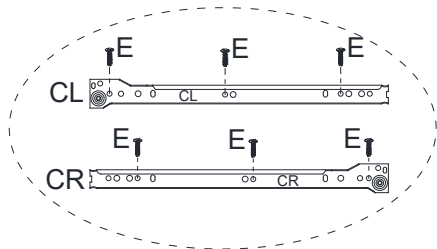

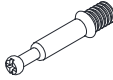

Step 1

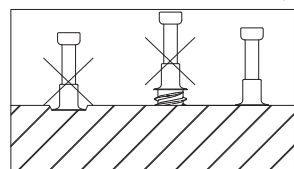
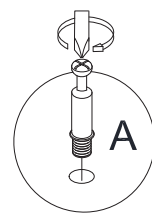
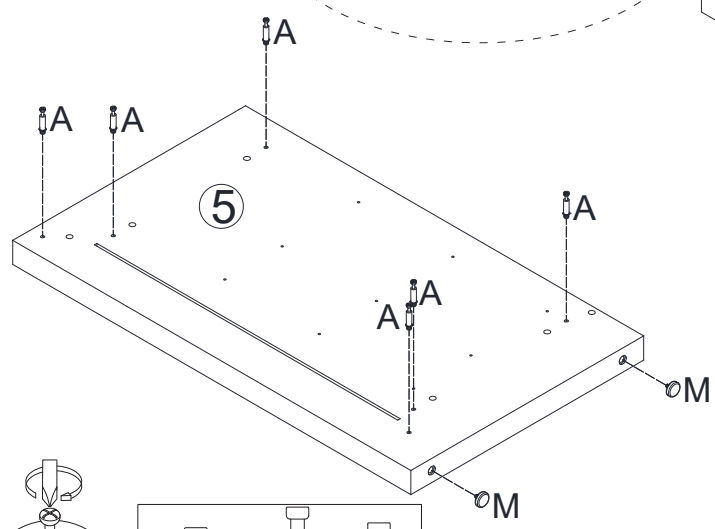
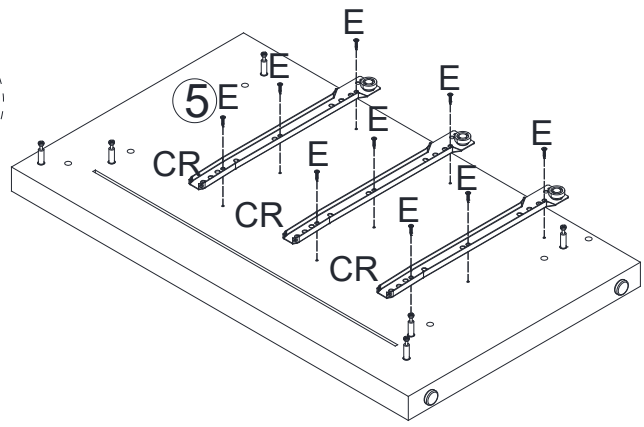
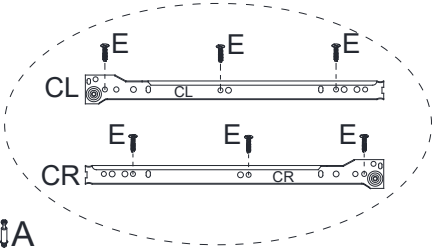

- CL  X 3
- M  X 2
- E  X 9
- A  X 6

Step 2



- CR  X 3
- M  X 2
- E  X 9
- A  X 6

Step 3

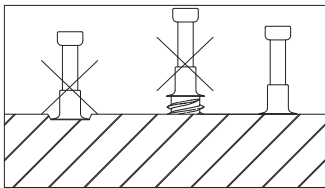
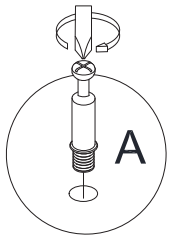
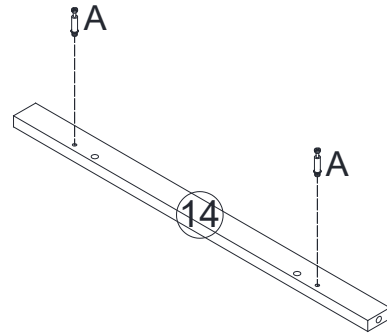
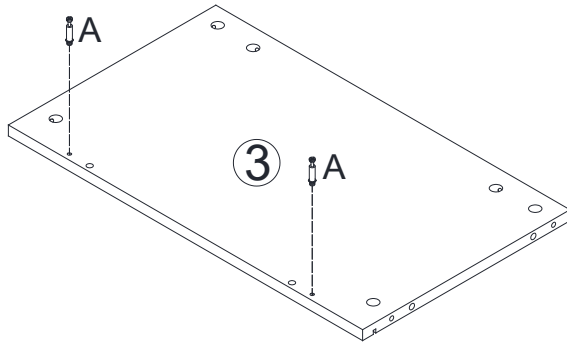

A

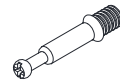

X 4

Step 4

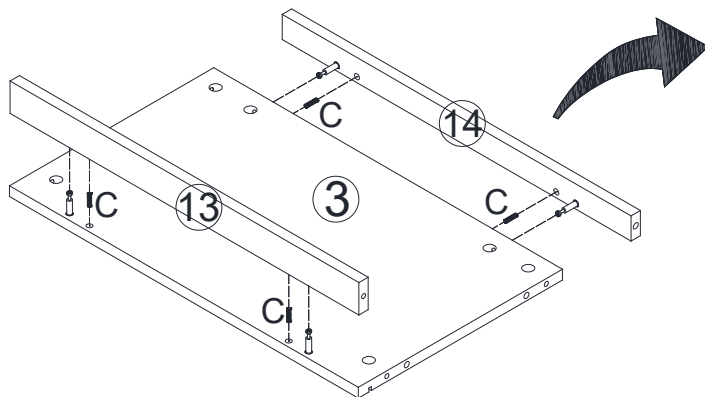
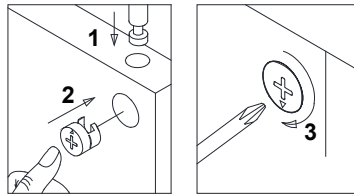

C



X 4

B



X 4

Step 5

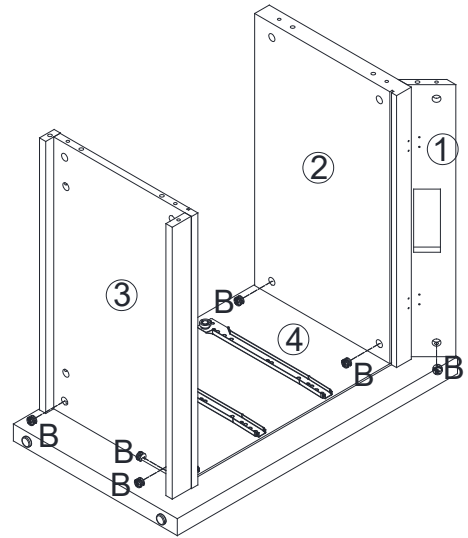
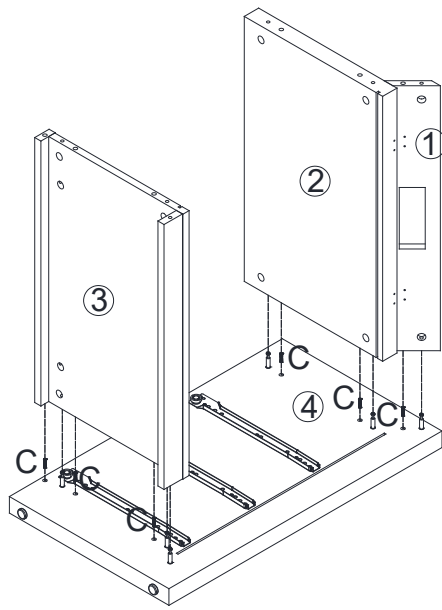
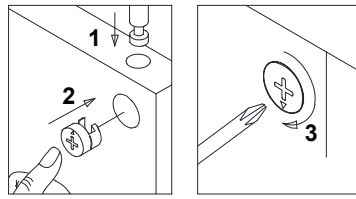

C



X 6

B



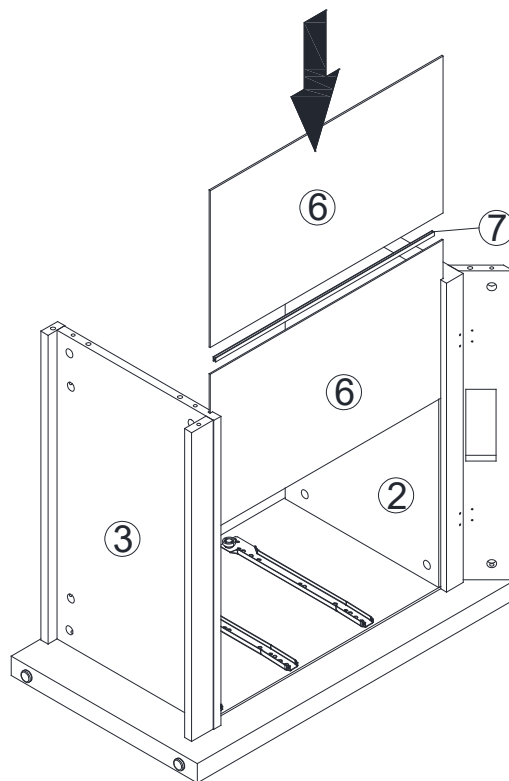

X 6

Step 6



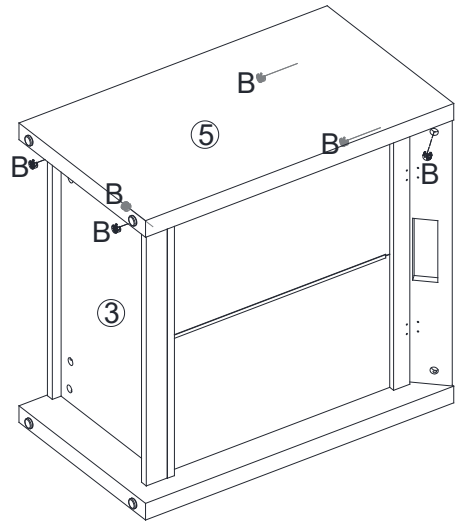
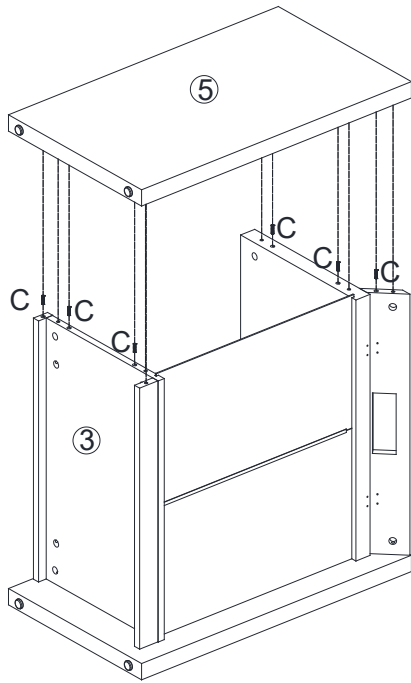

Step 7

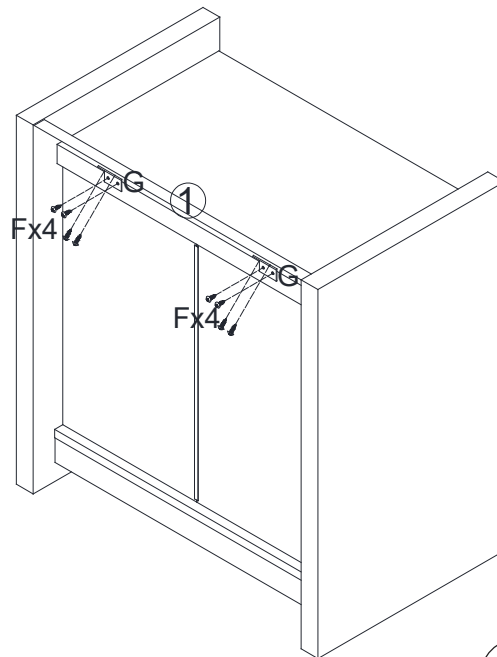
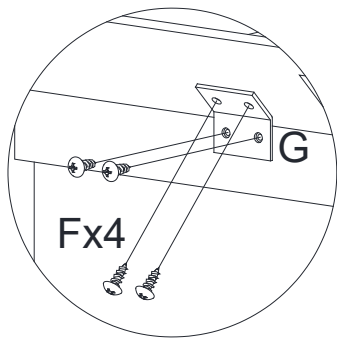

- C**  X 6
- B**  X 6

Step 8



- G**  X 2
- F**  X 8

Step 9

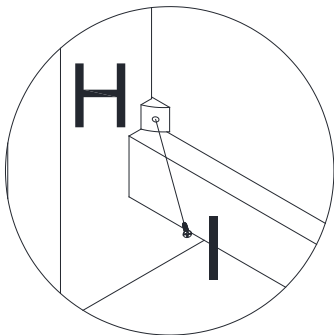
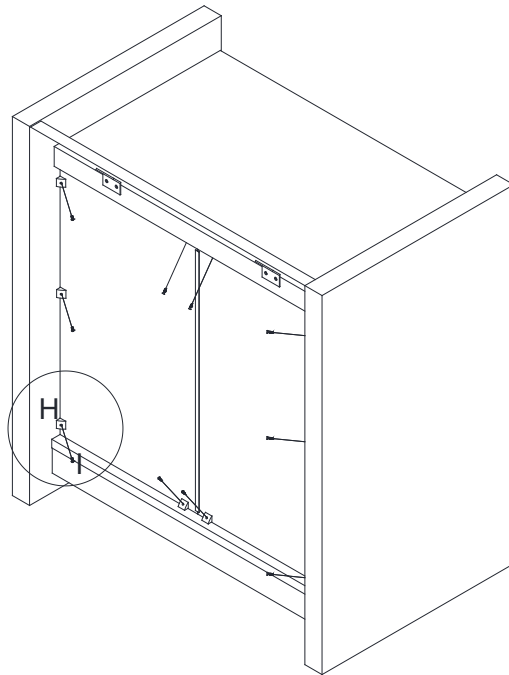

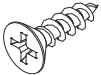
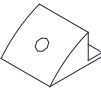
- | | | |
|---|---|------|
| I |  | X 10 |
| H |  | X 10 |

Step 10

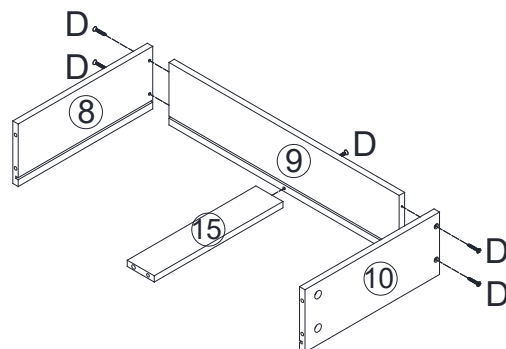
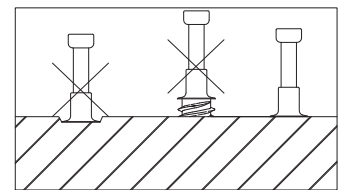
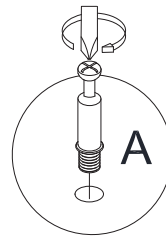
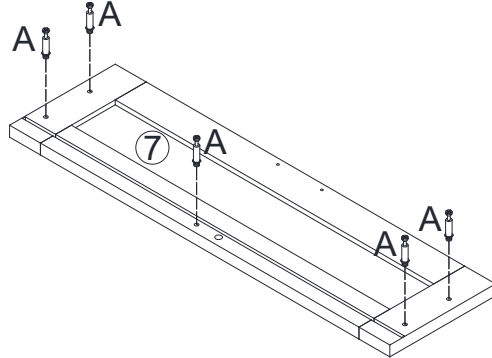

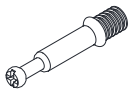

x3

- | | | |
|---|---|------|
| D |  | X 15 |
| A |  | X 15 |

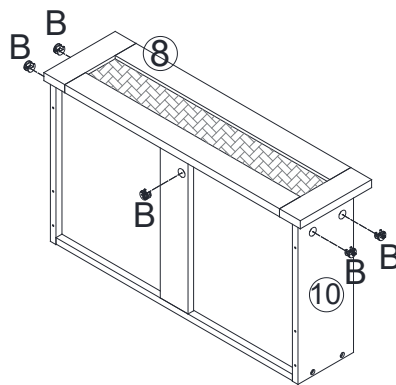
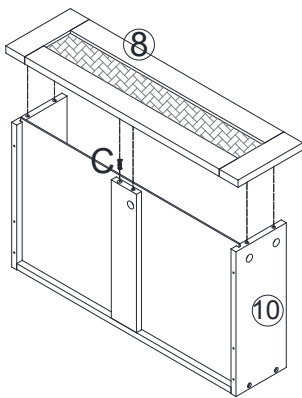
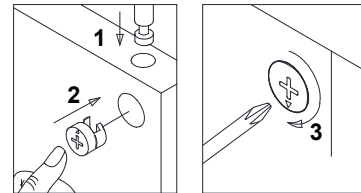
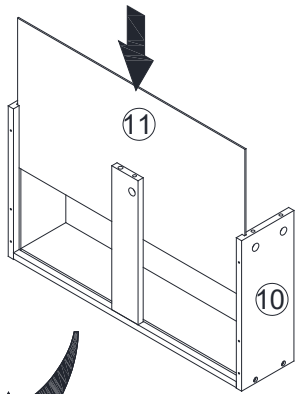
Step 11



x3



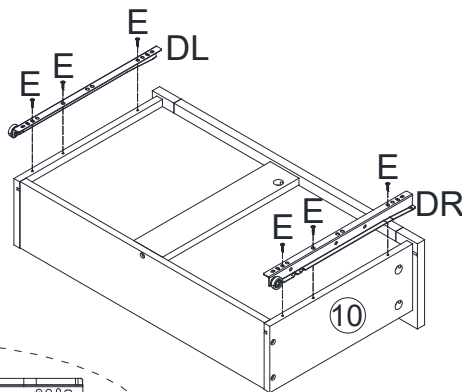

- C**  X 3
- B**  X 15

Step 12

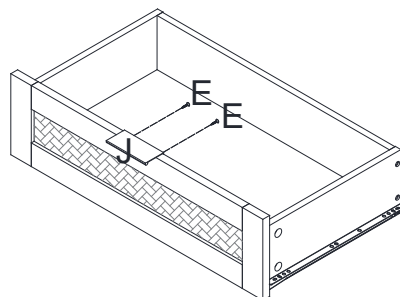
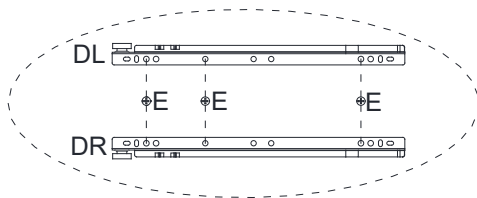

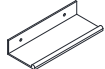

x3

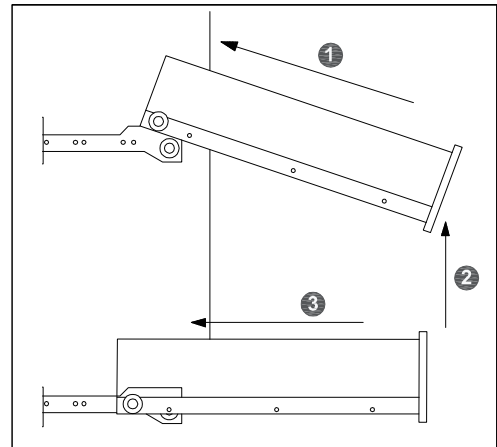
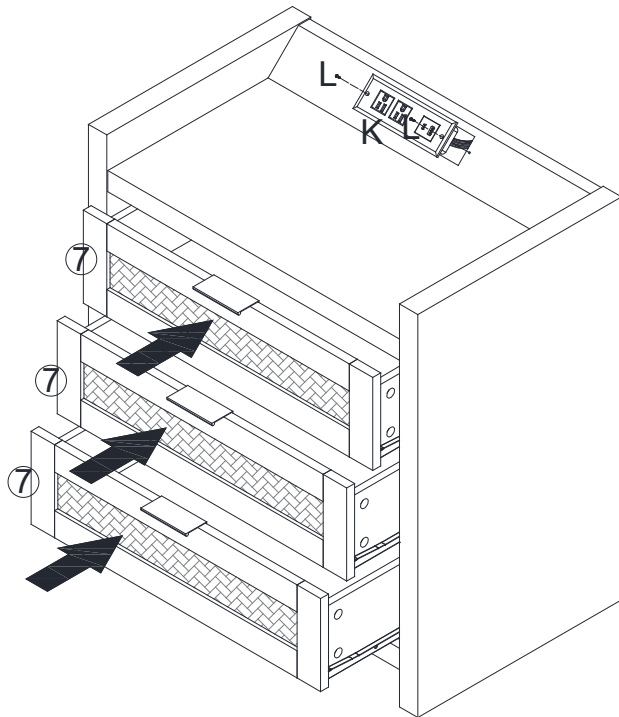

- DR**  X 3
- DL**  X 3
- J**  X 3
- E**  X 24

Step 13



- K**  X 1
- L**  X 2

Step 14

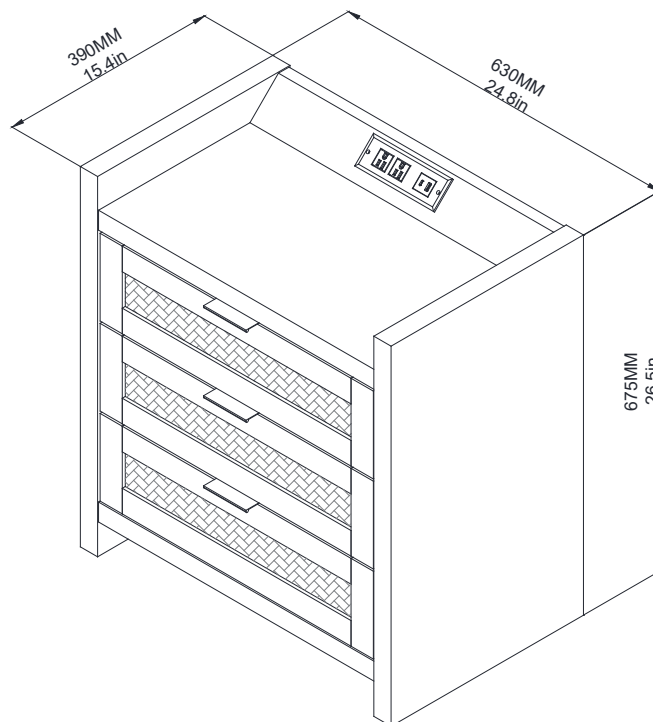

Final assembly