

ASSEMBLY INSTRUCTIONS

DEAR CUSTOMER,

Caution:

1. Please read all instructions before assembly and check the carton for any parts that may have come loose during shipment. It is recommended to use two or more persons during the assembly process.
2. Please do not discard any packaging before you have checked all the parts and fittings are included. If for any reason this product needs to be returned it must be returned packed in its original packaging.
3. Assemble this product on a flat and clean surface to avoid scratching.
4. Please don't tighten the screws completely and go back later for a final tightening of all the screws after pieces are aligned with each other!

DJ504125

DJ504126

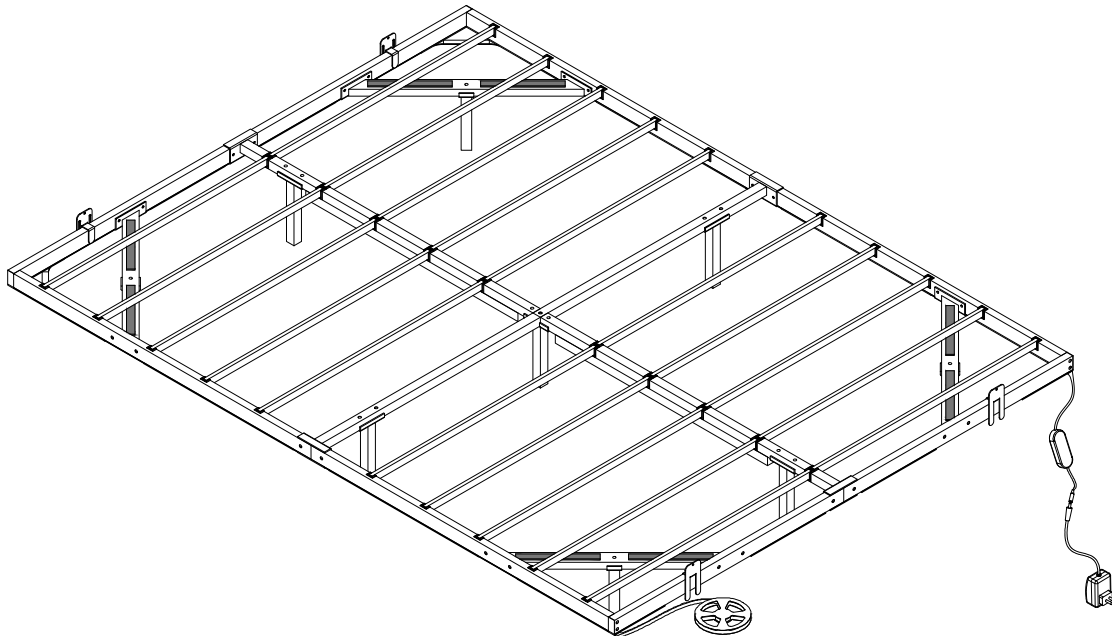

You can choose mobile control or 2.4G Remote Control.
First, pull out the plastic card on the 2.4G Remote Controller
and power on the 2.4G Remote Controller.

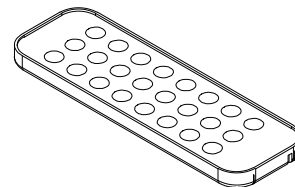

Mobile phone control steps:

1. Connect LED Lamp and 2.4G remote control.
2. Plug in the Adaptor Power supply.
3. Scan the 2.4G remote control OR code on the remote control and download the software Lotus Lantern.
4. Turn on the Bluetooth function of the mobile phone and search for Bluetooth pairing "Trinoes".
5. Open the "LotusLantern" APP and switch colors change.
Click the music switch to realize the skip mode of different LED lights.
Press the timing switch to realize the automatic light off function.etc





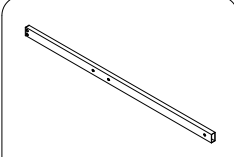
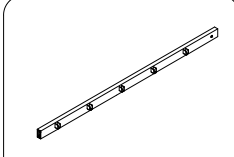
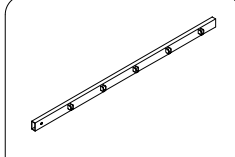
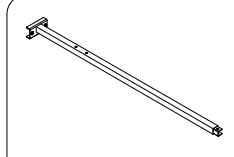
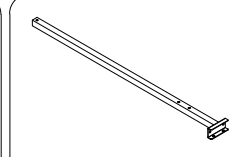
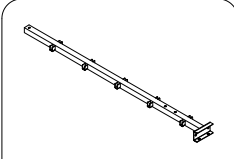
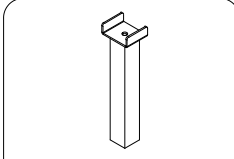
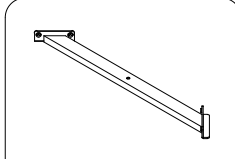
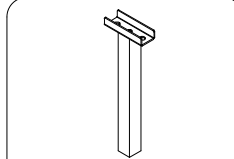
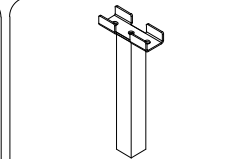
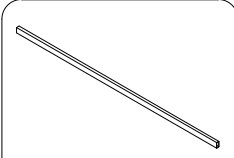
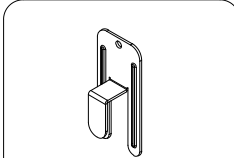
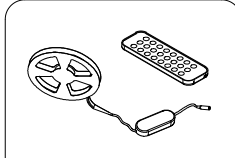
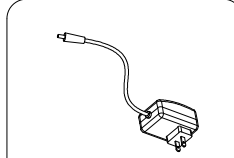

Parts List

 Pls make sure all the accesories are complete!

				
① 4PCS	② 2PCS	③ 2PCS	④ 1PC	⑤ 1PC
				
⑥ 2PCS	⑦ 4PCS	⑧ 4PCS	⑨ 4PCS	⑩ 1PC
				
⑪ 20PCS	⑫ 4PCS	⑬ 1PC	⑭ 1PC	⑮ 8PCS

Hardware List

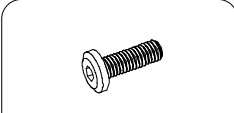
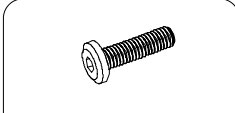
 Pls make sure all the accesories are complete!

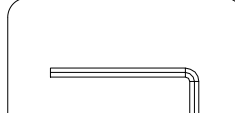

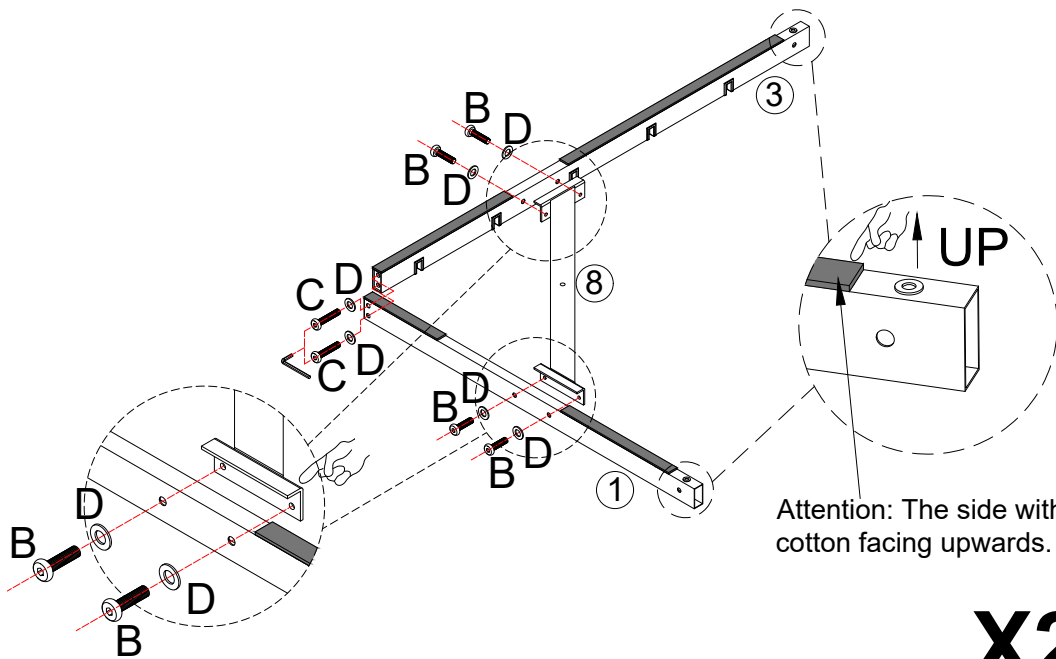
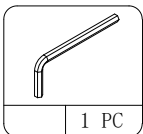
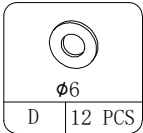
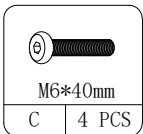
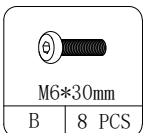
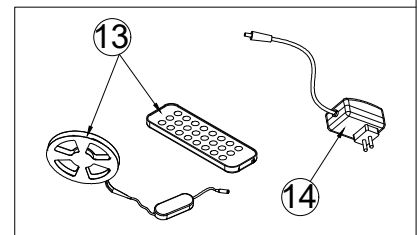
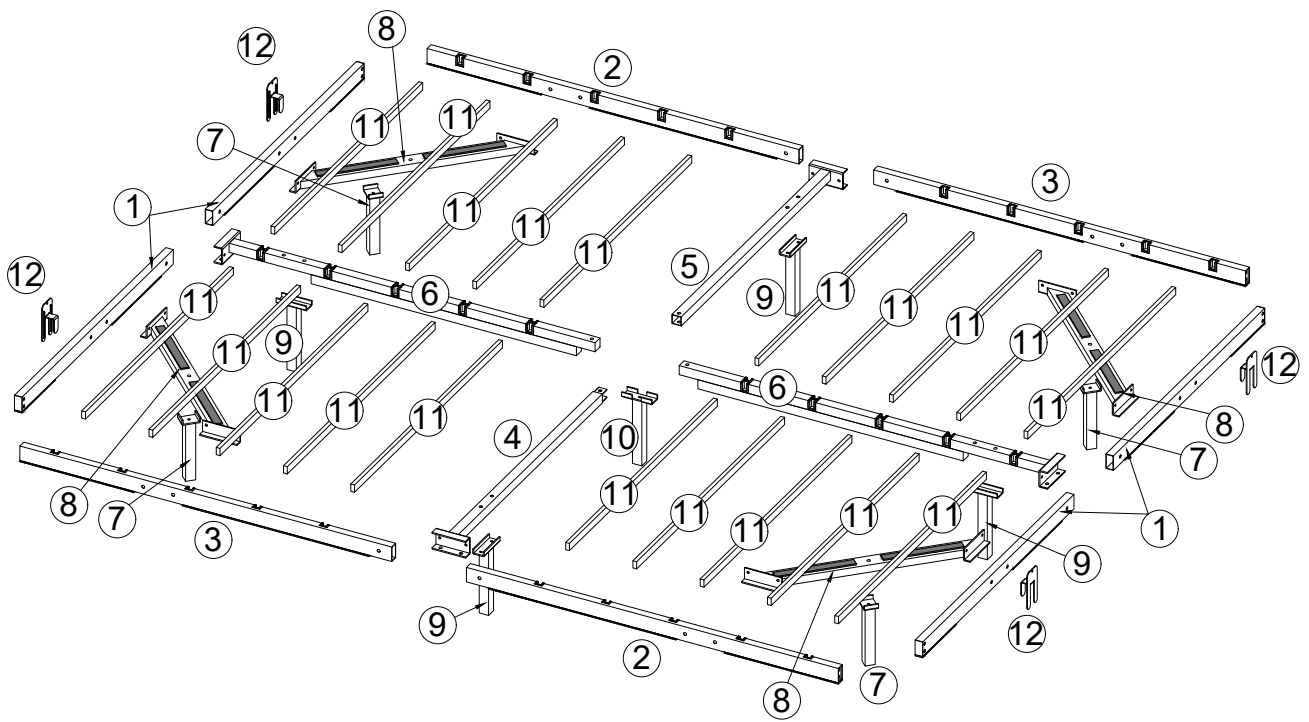

				
M6*15mm	M6*30mm	M6*40mm	φ6	
Ⓐ 8PCS	Ⓑ 28PCS	Ⓒ 19PCS	Ⓓ 55PCS	1PC



Attention: The side with silent cotton facing upwards.

X2

2

M6*30mm
B 8 PCS

M6*40mm
C 4 PCS

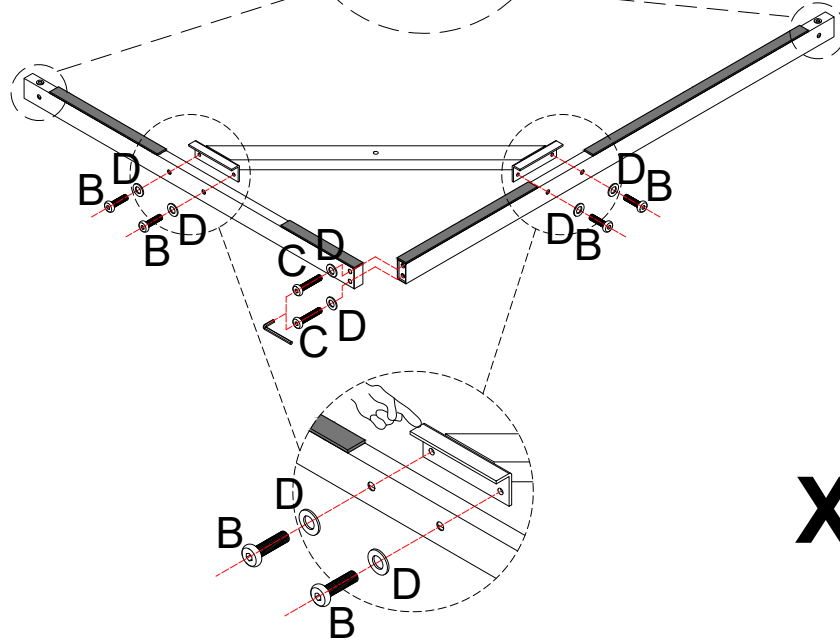
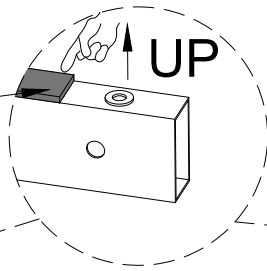
φ6
D 12 PCS

1 PC





Attention: The side with silent cotton facing upwards.



X2

Please don't tighten the screws completely.

3

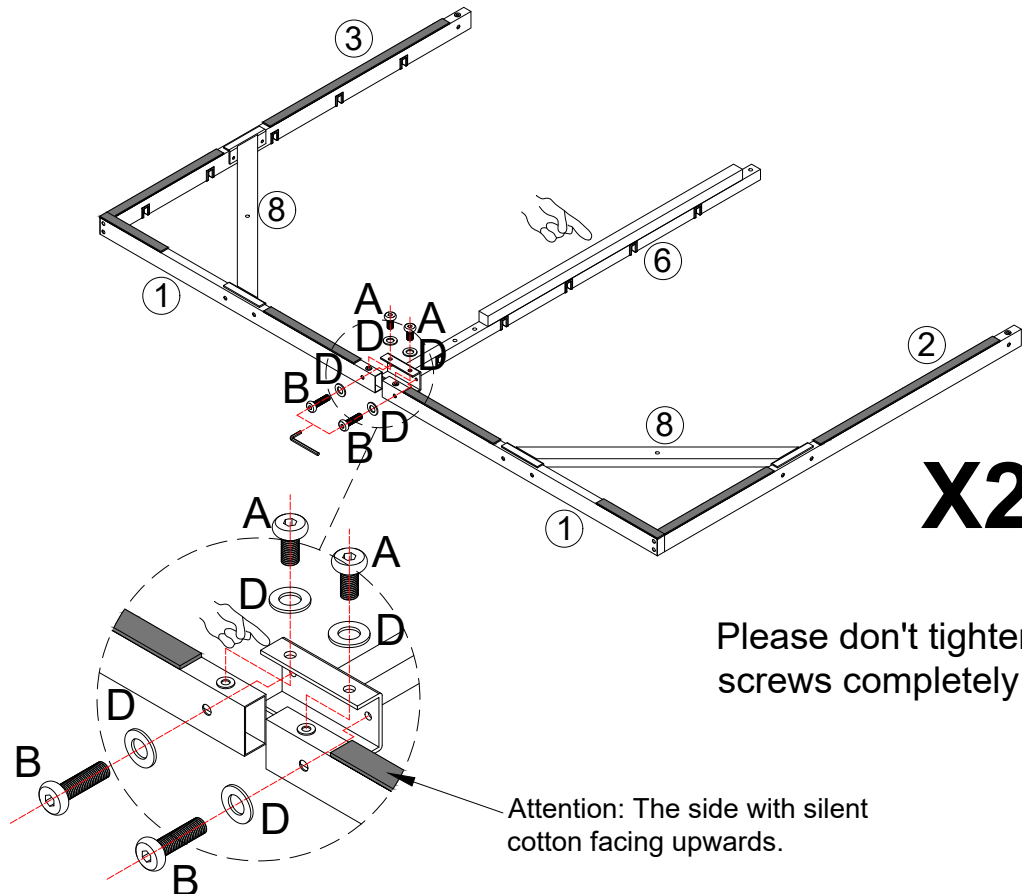

M6*15mm
A 4 PCS

M6*30mm
B 4 PCS

φ6
D 8 PCS

1 PC

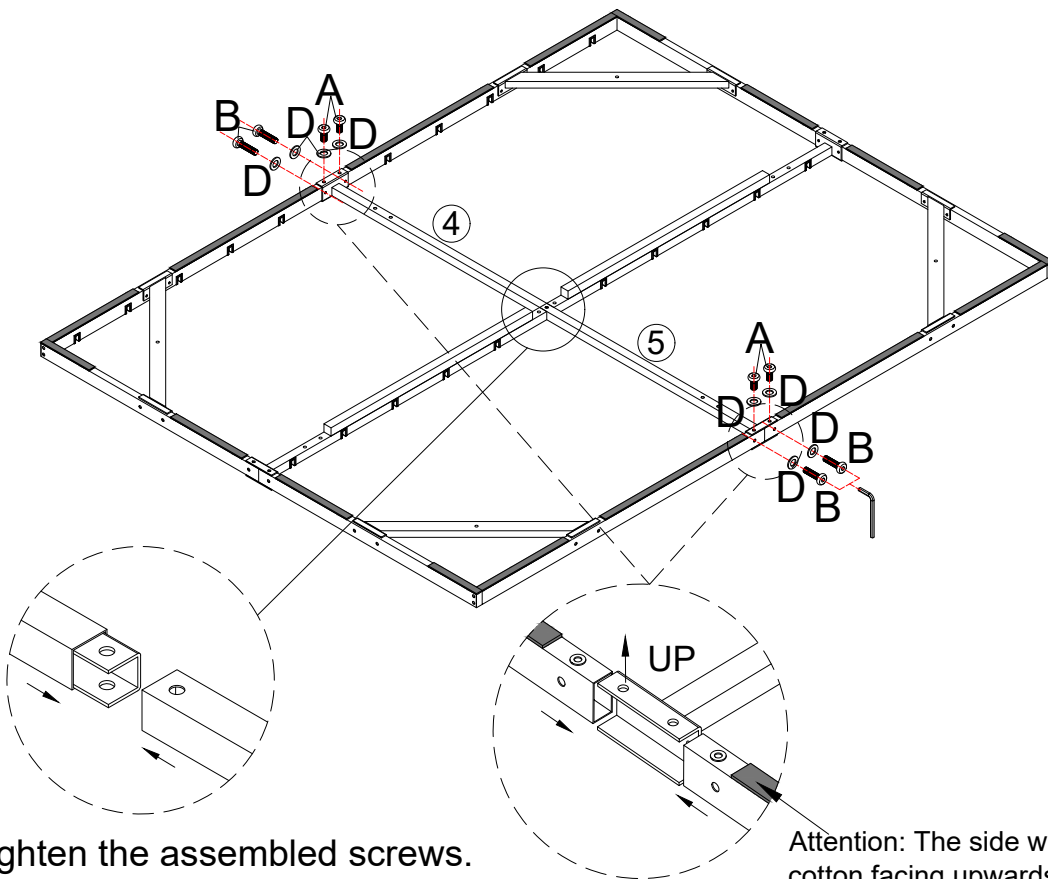
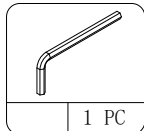
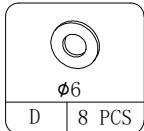
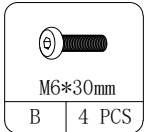
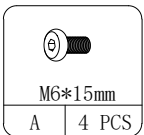

X2

Please don't tighten the screws completely.

Attention: The side with silent cotton facing upwards.



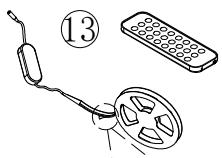

Please tighten the assembled screws.

Attention: The side with silent cotton facing upwards.



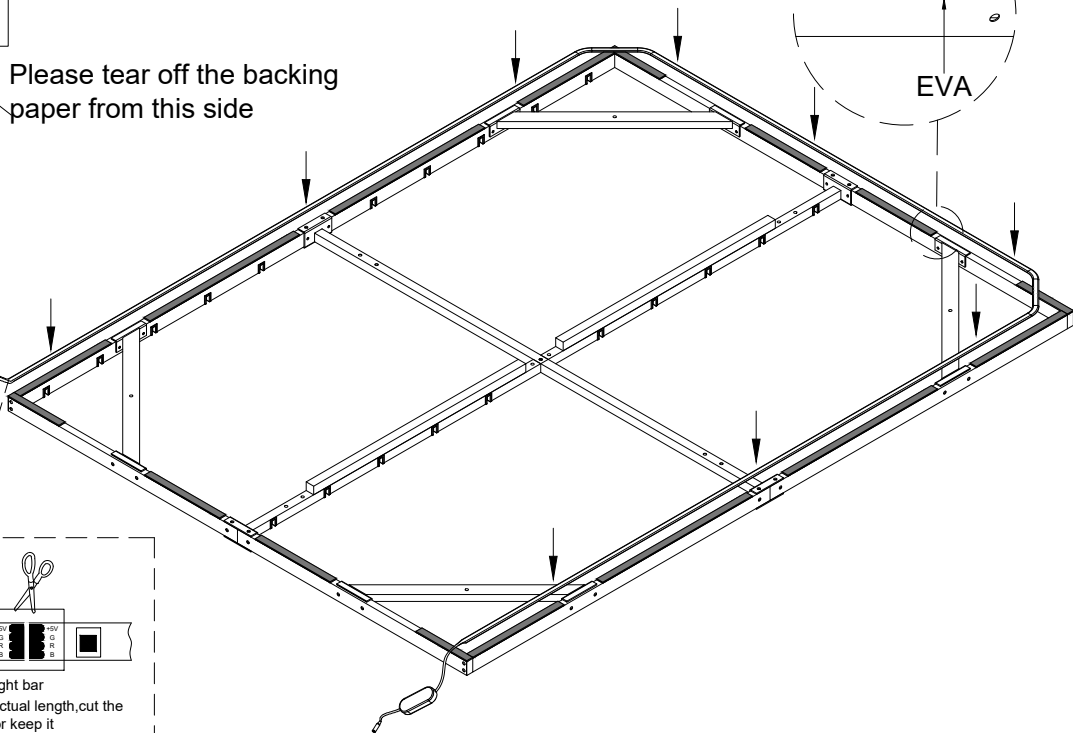
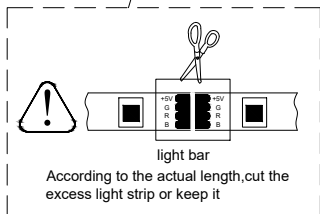
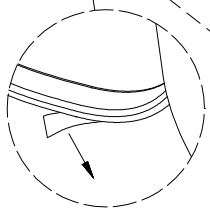
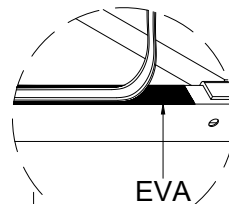

Please tear off the backing paper from this side

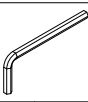

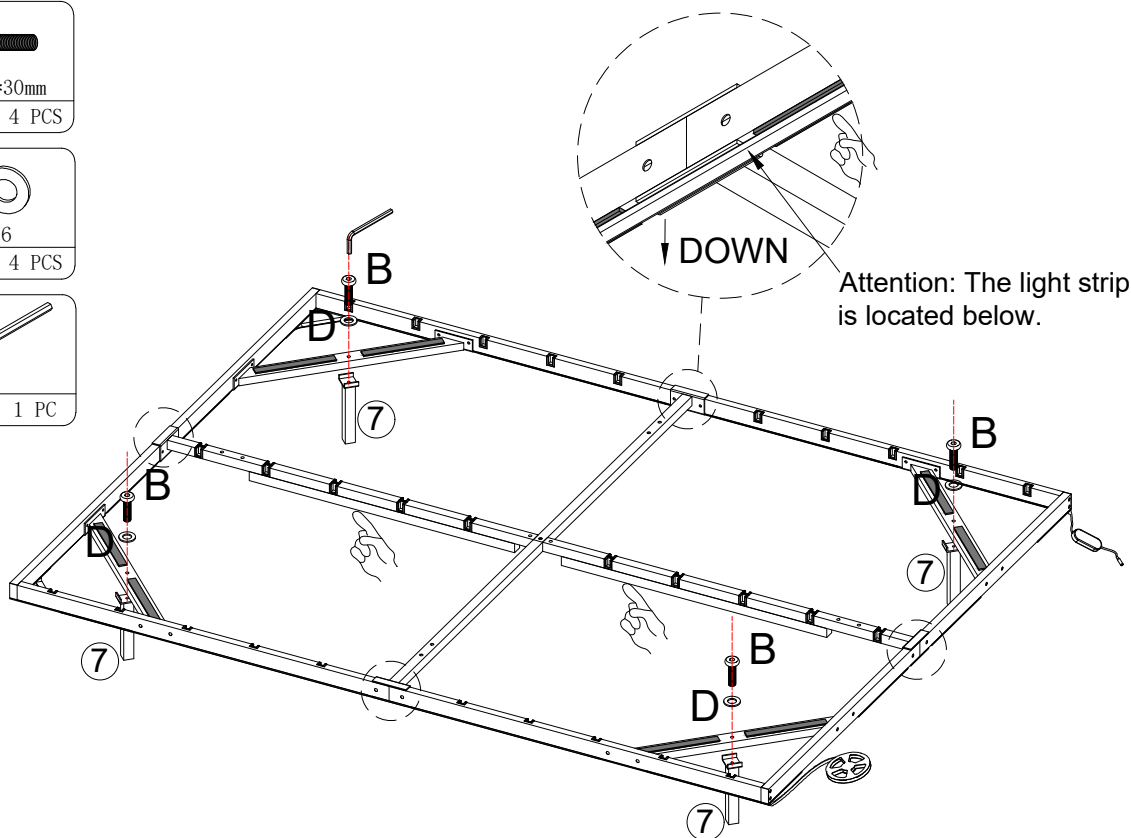
-  M6*30mm
B 4 PCS
-  Ø6
D 4 PCS
-  1 PC



-  M6*40mm
C 3 PCS
-  Ø6
D 3 PCS
-  1 PC

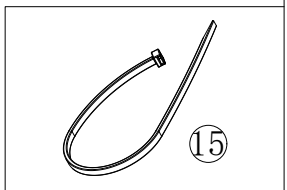
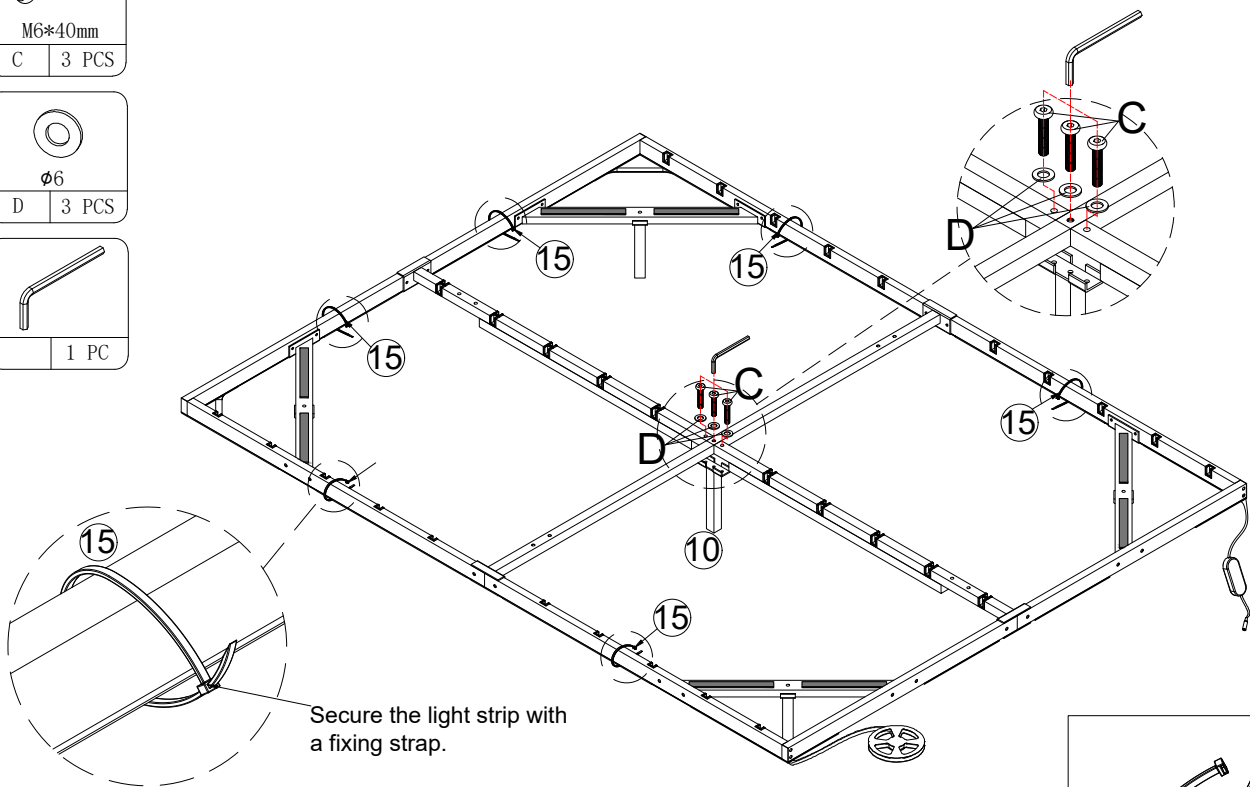

8

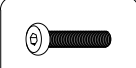
	M6*40mm
C	8 PCS

	ø6
D	8 PCS

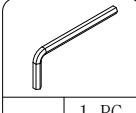
	1 PC
---	------

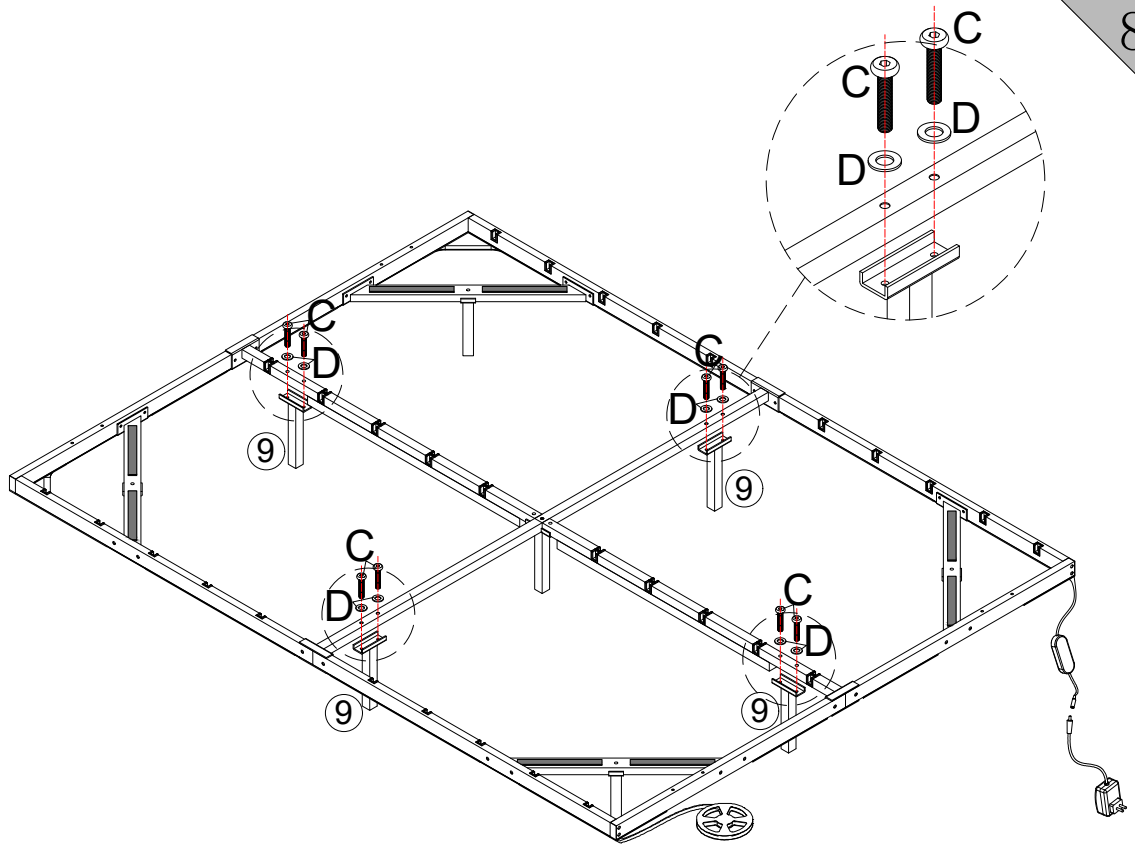

Please tighten all screws at the end of each screw alignment.

9

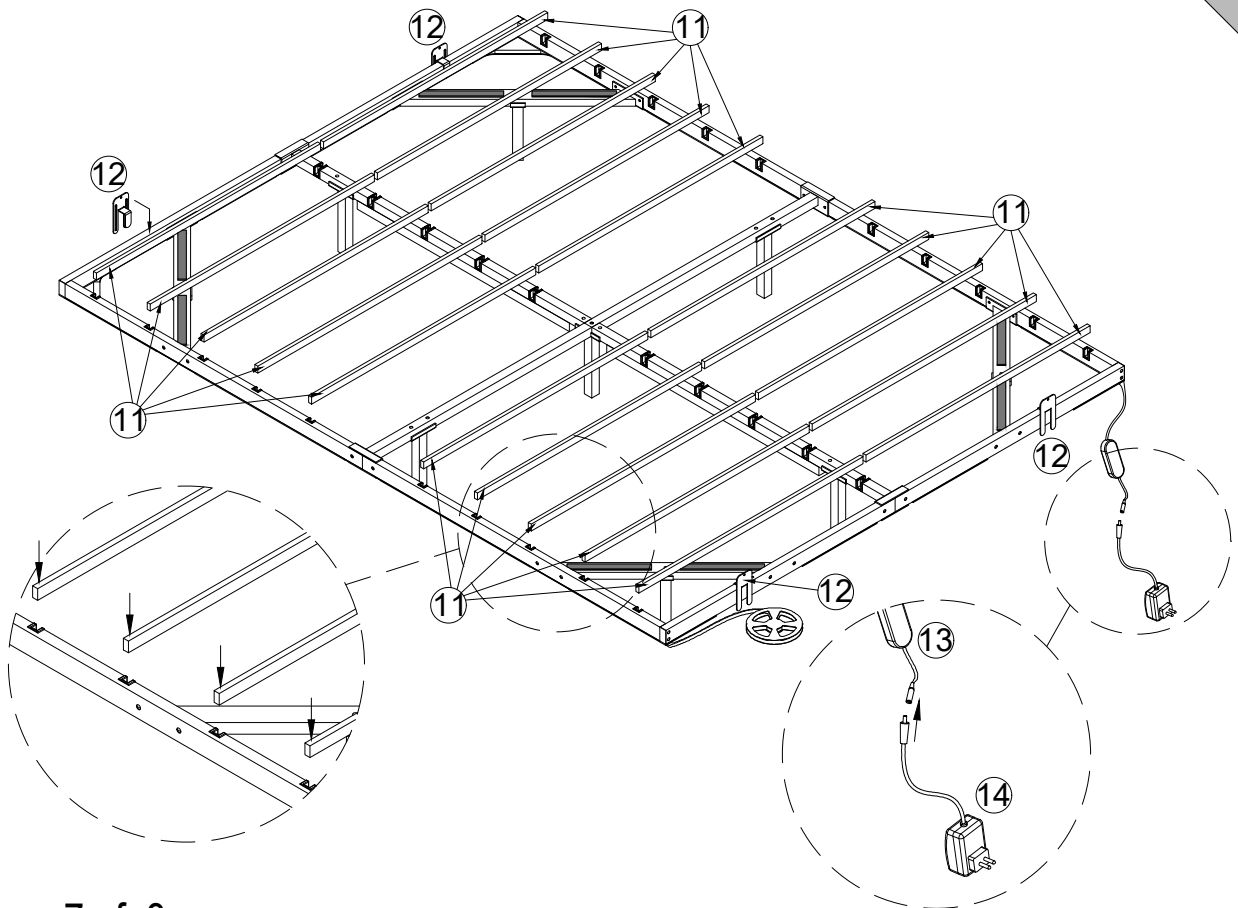

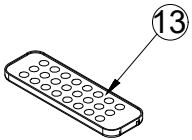

You can choose mobile control or 2.4G Remote Control
First, pull out the plastic card on the 2.4G Remote Controller
and power on the 2.4G Remote Controller.

Mobile phone control steps:

1. Connect LED Lamp and 2.4G remote control.
2. Plug in the Adaptor Power supply.
3. Scan the 2.4G remote control OR code on the remote control and download the software Lotus Lantern.
4. Turn on the Bluetooth function of the mobile phone and search for Bluetooth pairing "Trinoes".
5. Open the "LotusLantern " APP and switch colors change.
Click the music switch to realize the skip mode of different LED lights.
Press the timing switch to realize the automatic light off function.etc

