

# ASSEMBLY INSTRUCTIONS

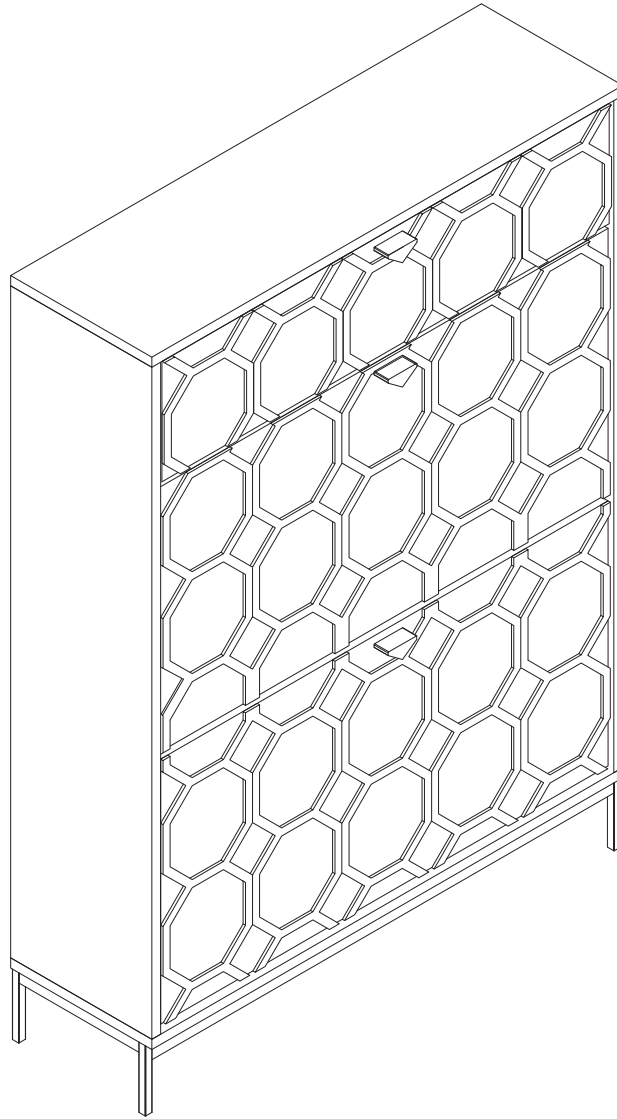

**WARNING:**

**TIPPING HAZARD.** This cabinet can tip over if not secured, causing serious injury or death. Always attach to the wall using the safety wall strap (Part U) provided. Never allow children to climb on doors or shelves.

U.S. Customer Service: (951) 213-4742 (Mon-Fri, 9AM-5PM PST)  
Email: [contactus24service@gmail.com](mailto:contactus24service@gmail.com)

Part list:

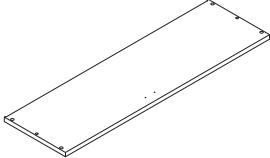
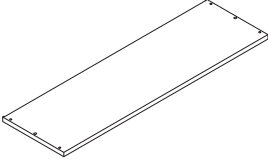
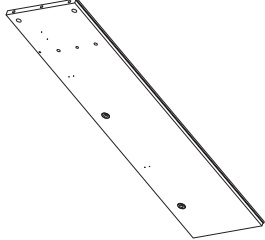
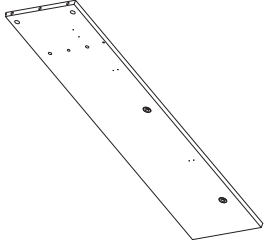
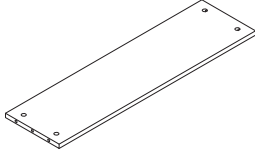
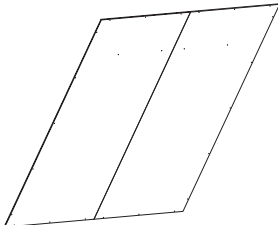
ITEM	DESCRIPTION	PART	QTY
1	Top panel		1
2	Bottom lamination		1
3	Left side panel		1
4	Right side panel		1
5	Shelf		1
6	Back panel		1

Part list:

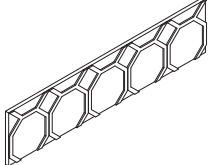
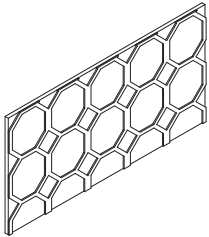
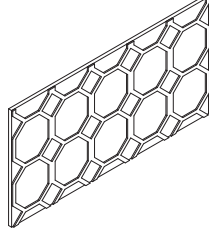
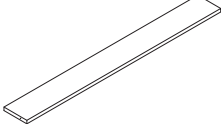
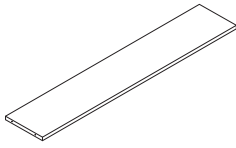
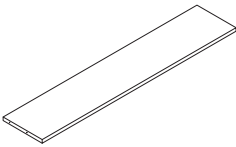
ITEM	DESCRIPTION	PART	QTY
7	Upper door panel		1
8	Lower door panel		1
9	Lower door panel		1
10	Bottom lamination		2
11	Back lamination		2
12	Middle lamination		2



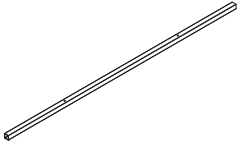



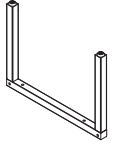



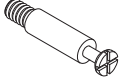

## Part list:

ITEM	DESCRIPTION	PART	QTY
13	Metal Strip		2



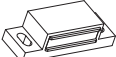

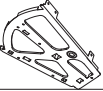
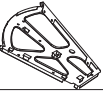





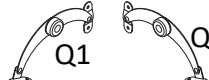

## Part list:

ITEM	DESCRIPTION	PART	QTY
14	Metal Leg		2

## Hardware List:

ITEM	DESCRIPTION	PART	QTY
A	Camlock bolt		8
B	Camlock		8
C	Wooden dowel	 Φ0.23*1.18"	6
D	Bolt	 Φ0.23*1.18"	8
E	Bolt	 Φ0.23*1.57"	4
F	Allen wrench		1
G	Handle		3
H	Machine screw	 Φ0.15*0.98"	6
I	Magnet		1
J	Wood screw	 Φ0.13*0.62"	30
K	Wood screw	 Φ0.11*0.47"	8
L	Left bracket		2
M	Right bracket		2
N	Screw button		4

## Hardware List:

ITEM	DESCRIPTION	PART	QTY
O	Screw	 Φ0.15*0.39"	4
P	Stopper		4
Q	Safety hinge	 Q1 Q2	1
R	Left hinge		1
S	Right hinge		1
T	Back screw	 Φ0.11*0.55"	26
U	Safety wall strap		2
V	Plastic anchor		2
W	Mounting screw	 Φ0.15*1.57"	2
X	Washer		2
Y	Wood screw	 Φ0.15*1.37"	4
Z	Wood screw	 Φ0.13*0.47"	20
a	Iron sheet		1

- \* Required screwdriver & mallet, not included.
- \* Before discarding packing materials, please check to make sure that all parts and hardware is present.
- \* Two people needed for assembly.
- \* Please follow the instructions closely; Do not over-tighten screws or bolts unless specified.
- \* After a few days from initial assembly, the product may adjust to the environment. Please retighten the hardware.

## Guideline For Assembling of Cam Lock (A & B)

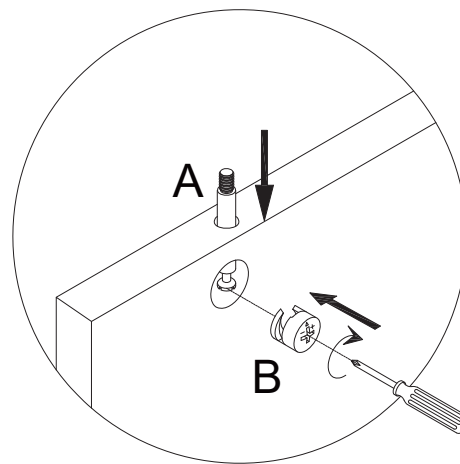
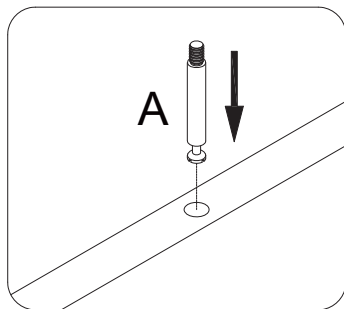



Screw camlock bolt (A) to wood part.

Do not assemble camlock (B) unless instructed.



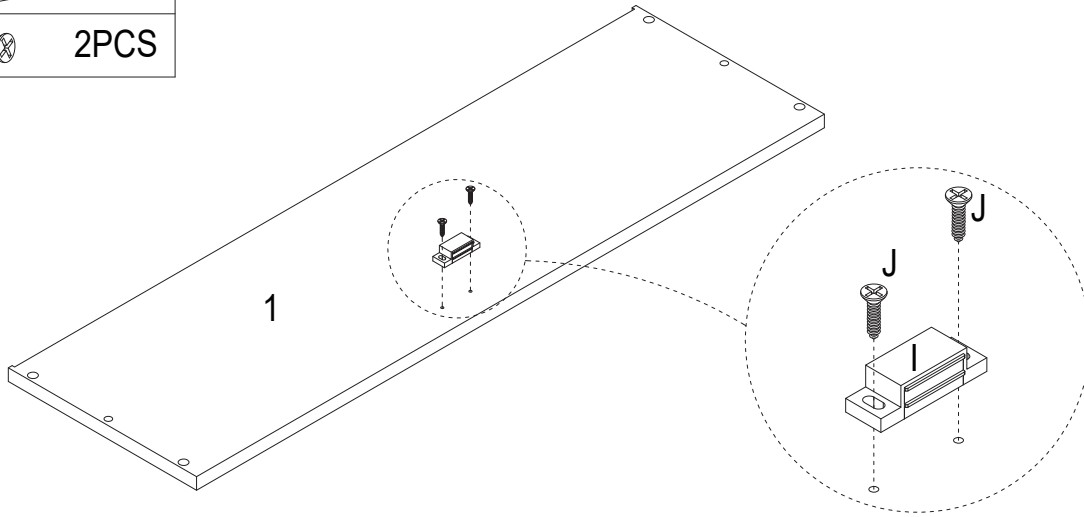

To assemble camlock (B), ensure long side of the + is facing the bolt (A) before inserting into hole.

## STEP 1

I:		1PC
J:		2PCS







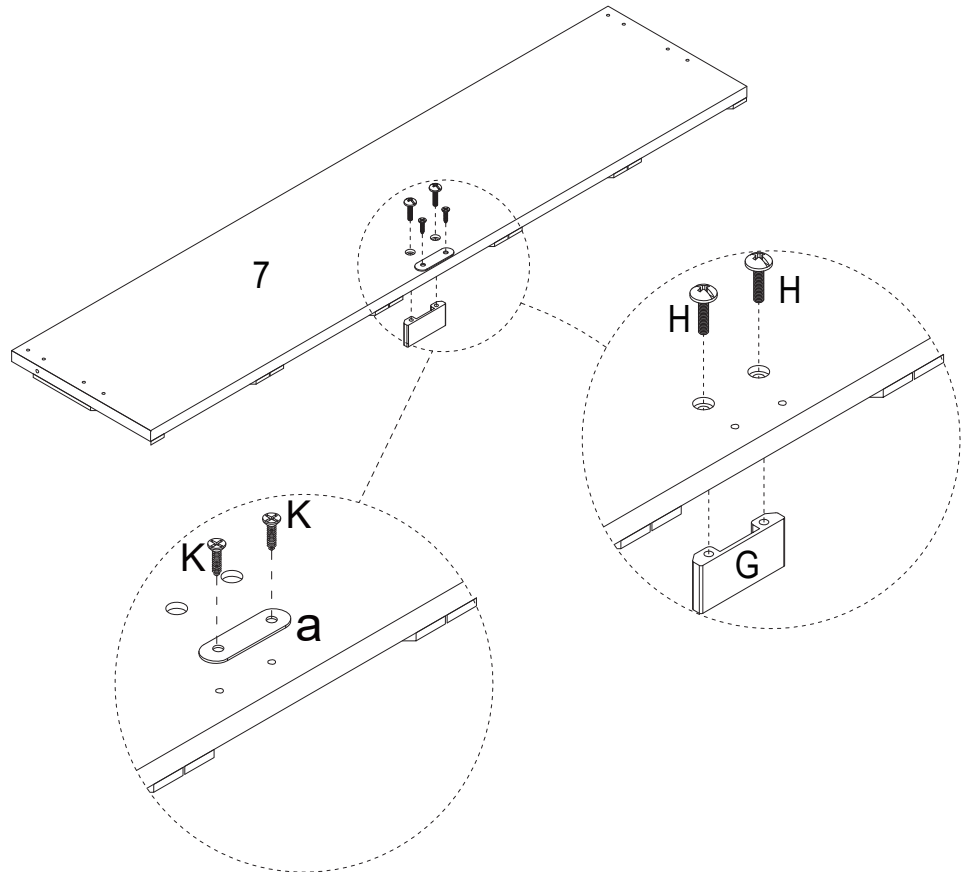

## STEP 2

G:		1PC
H:		2PCS
K:		2PCS
a:		1PC







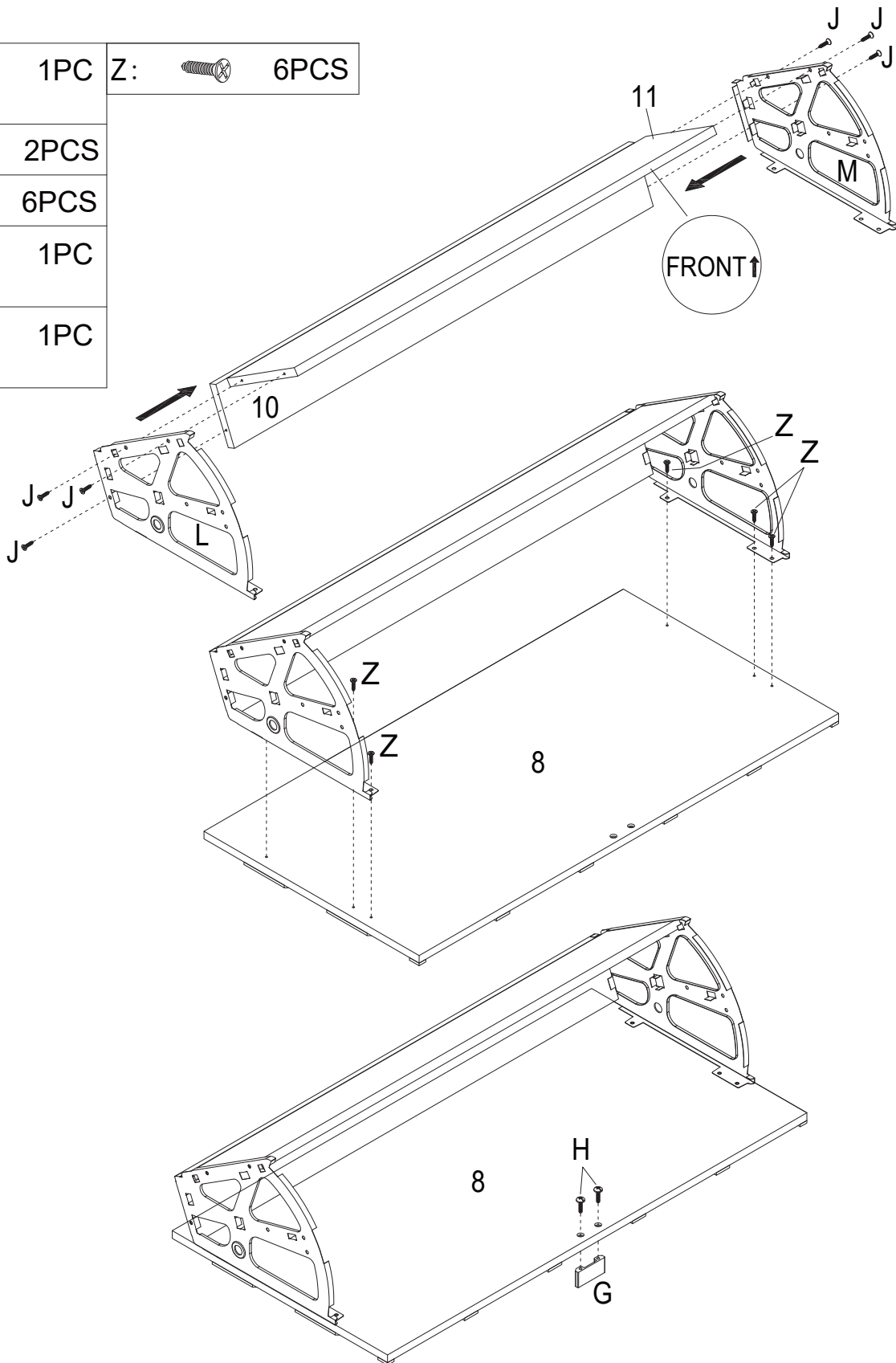

## STEP 3

G:		1PC	Z:		6PCS
H:		2PCS			
J:		6PCS			
L:		1PC			
M:		1PC			



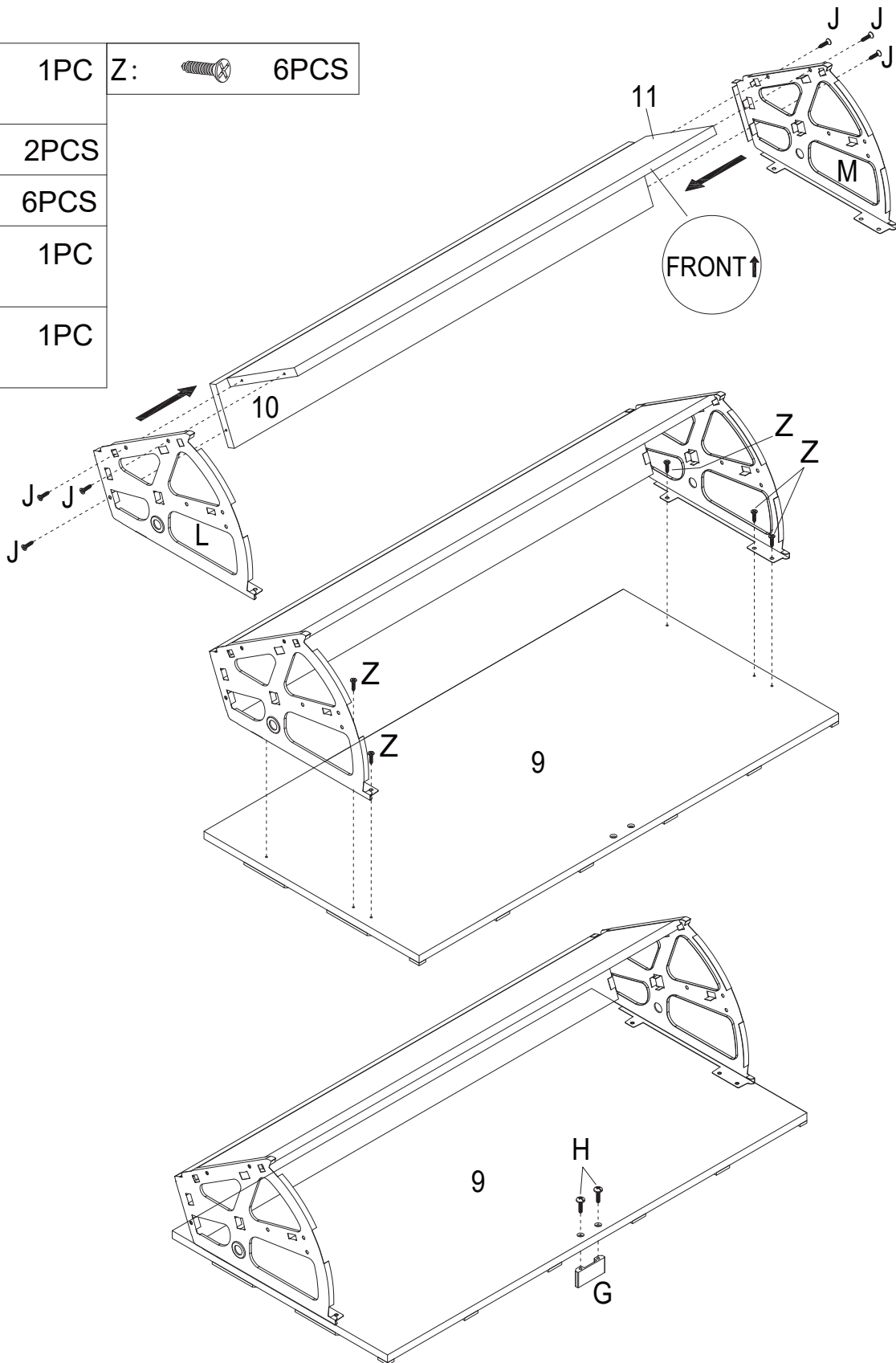

## STEP 4

G:		1PC	Z:		6PCS
H:		2PCS			
J:		6PCS			
L:		1PC			
M:		1PC			



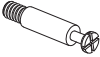

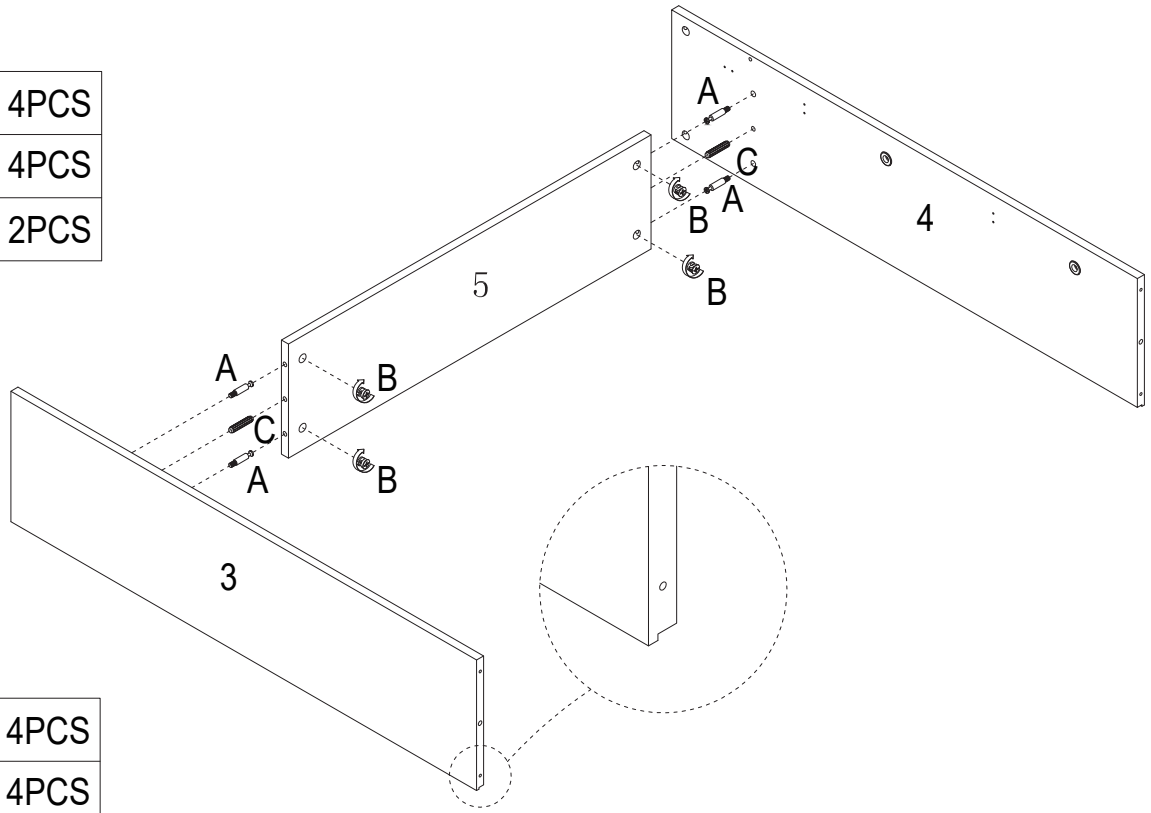

## STEP 5

A:		4PCS
B:		4PCS
C:		2PCS

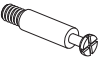

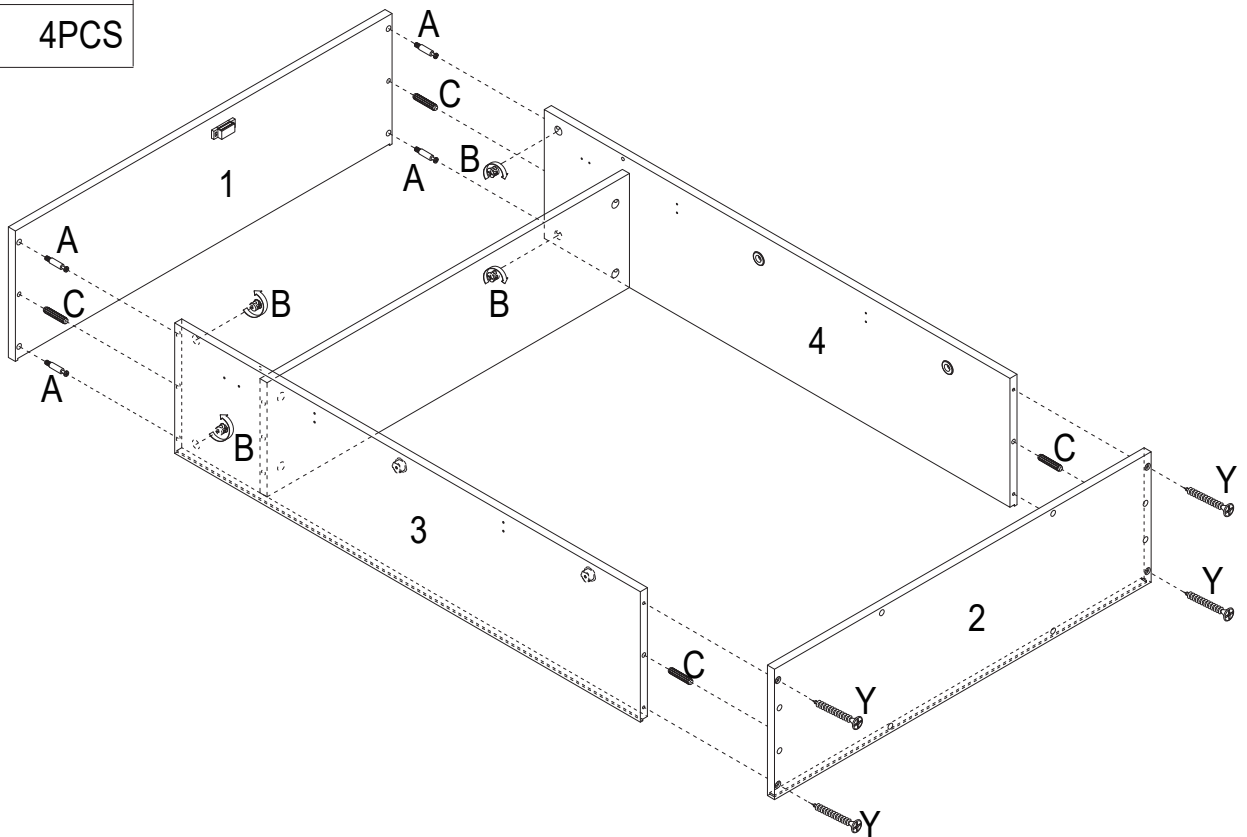

## STEP 6

A:		4PCS
B:		4PCS
C:		4PCS
Y:		4PCS



## STEP 7

E:		4PCS
F:		1PC

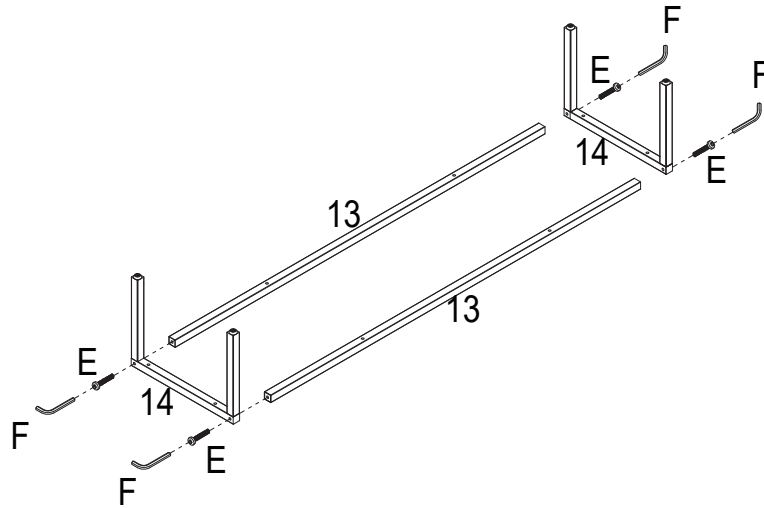

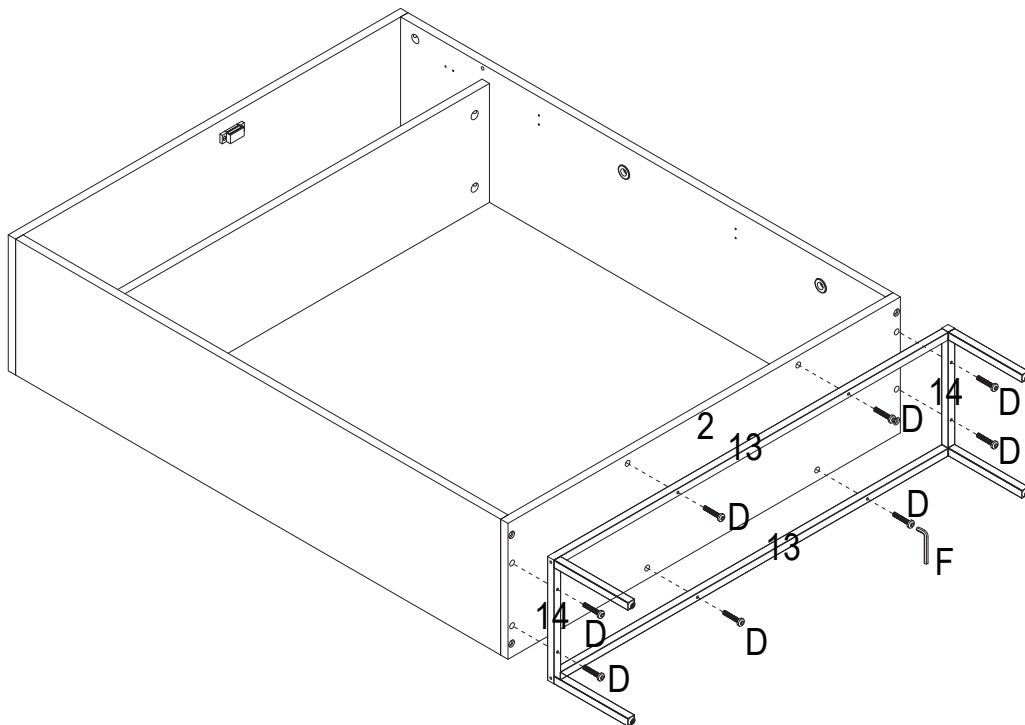

## STEP 8

D:		8PCS
----	---	------





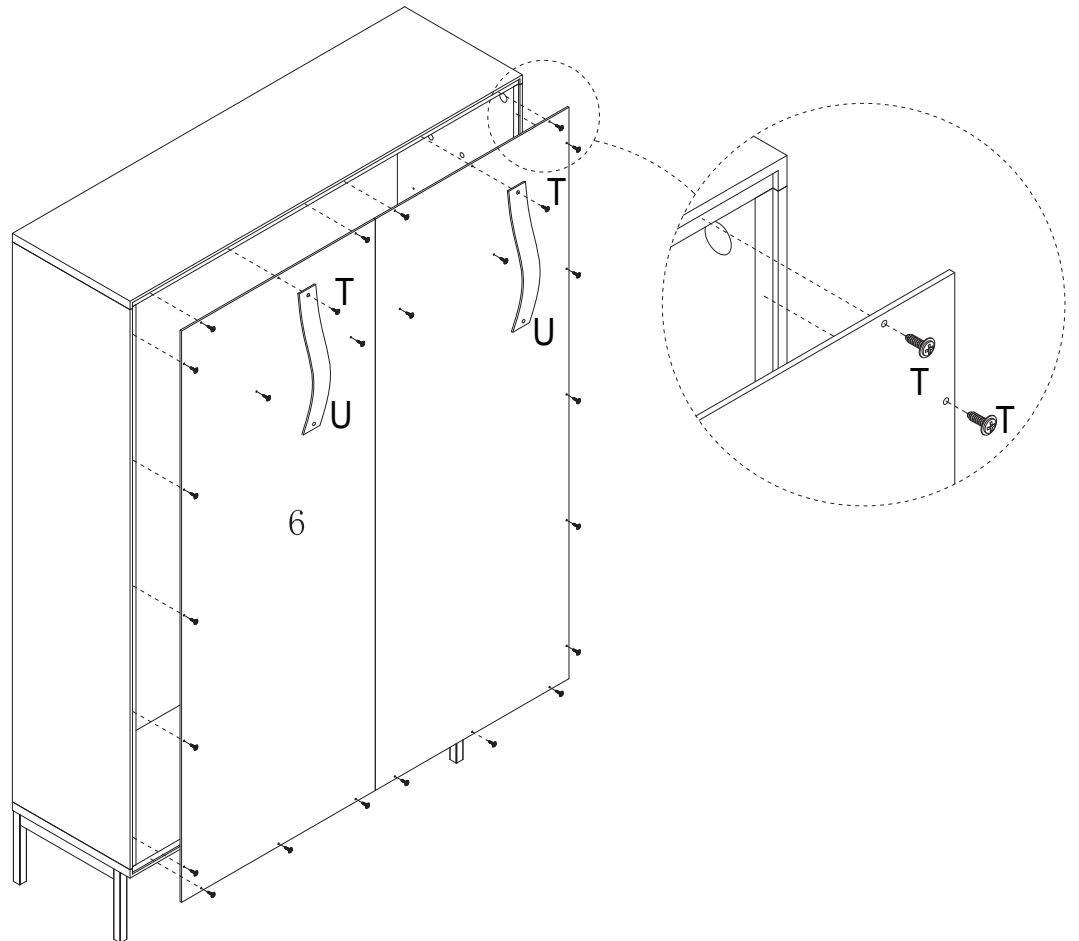

## STEP 9

T:		26PCS
U:		2PCS



## STEP 10

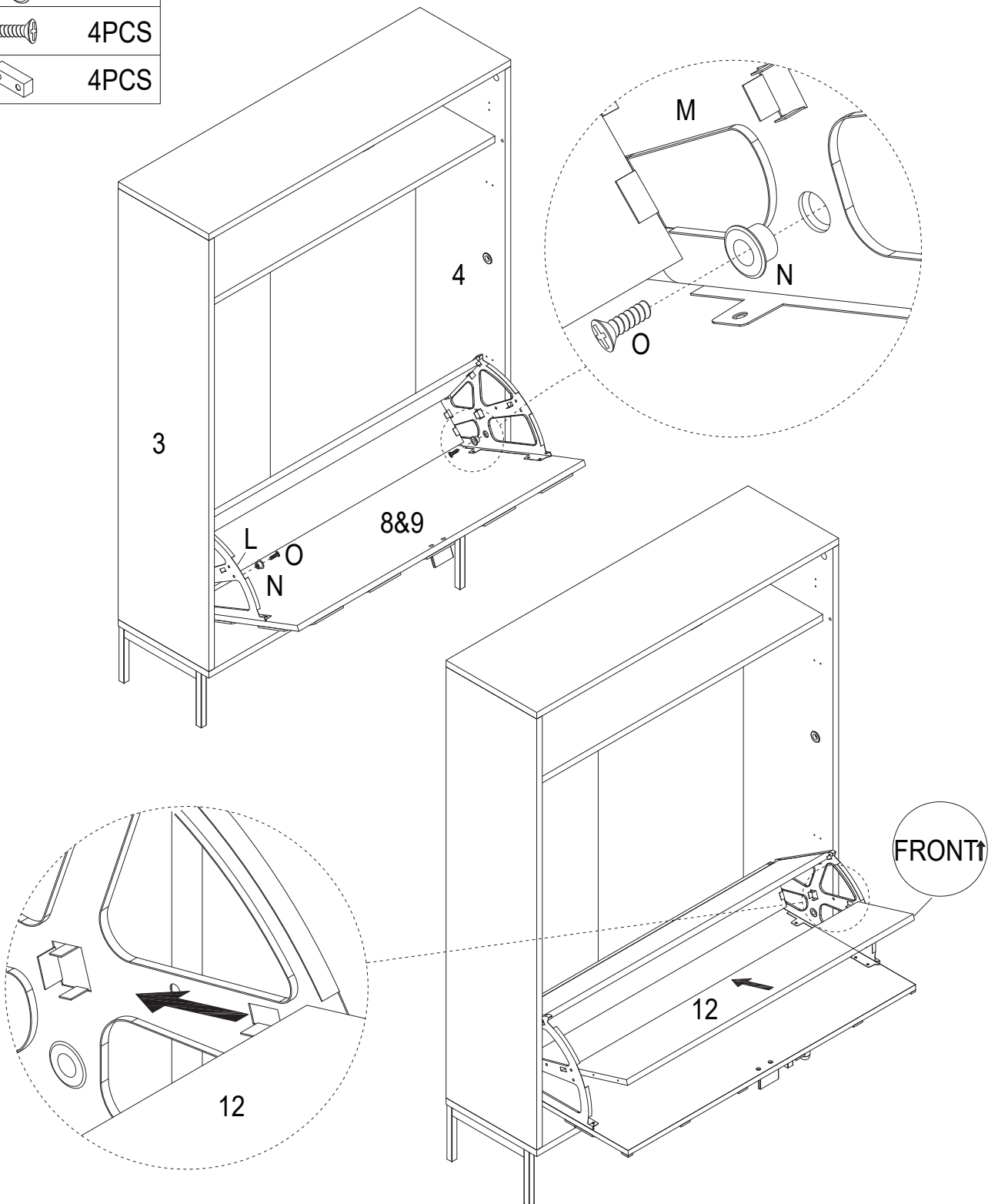

Repeat step 10 for the other shoe storage.

J:		16PCS
N:		4PCS
O:		4PCS
P:		4PCS

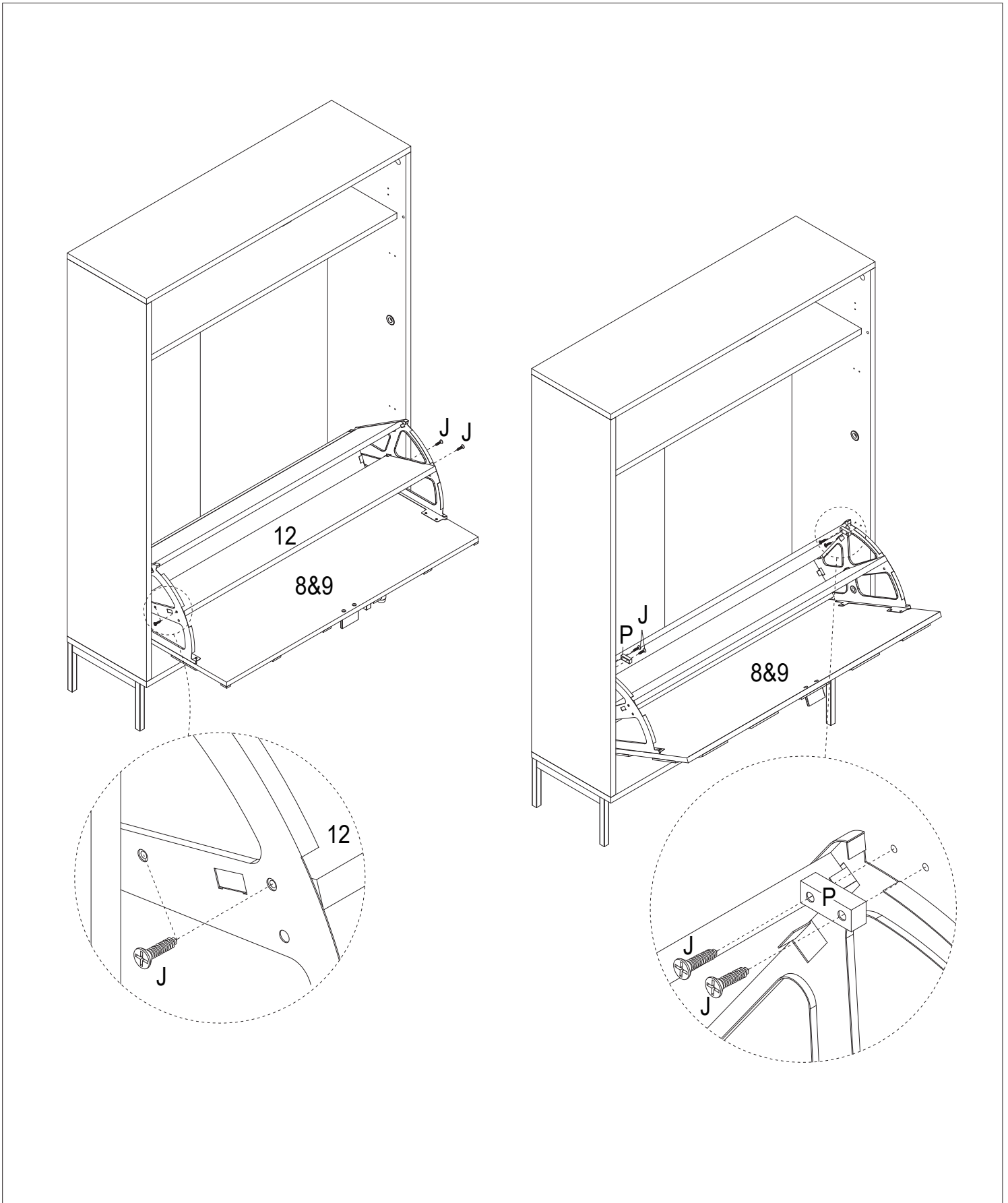



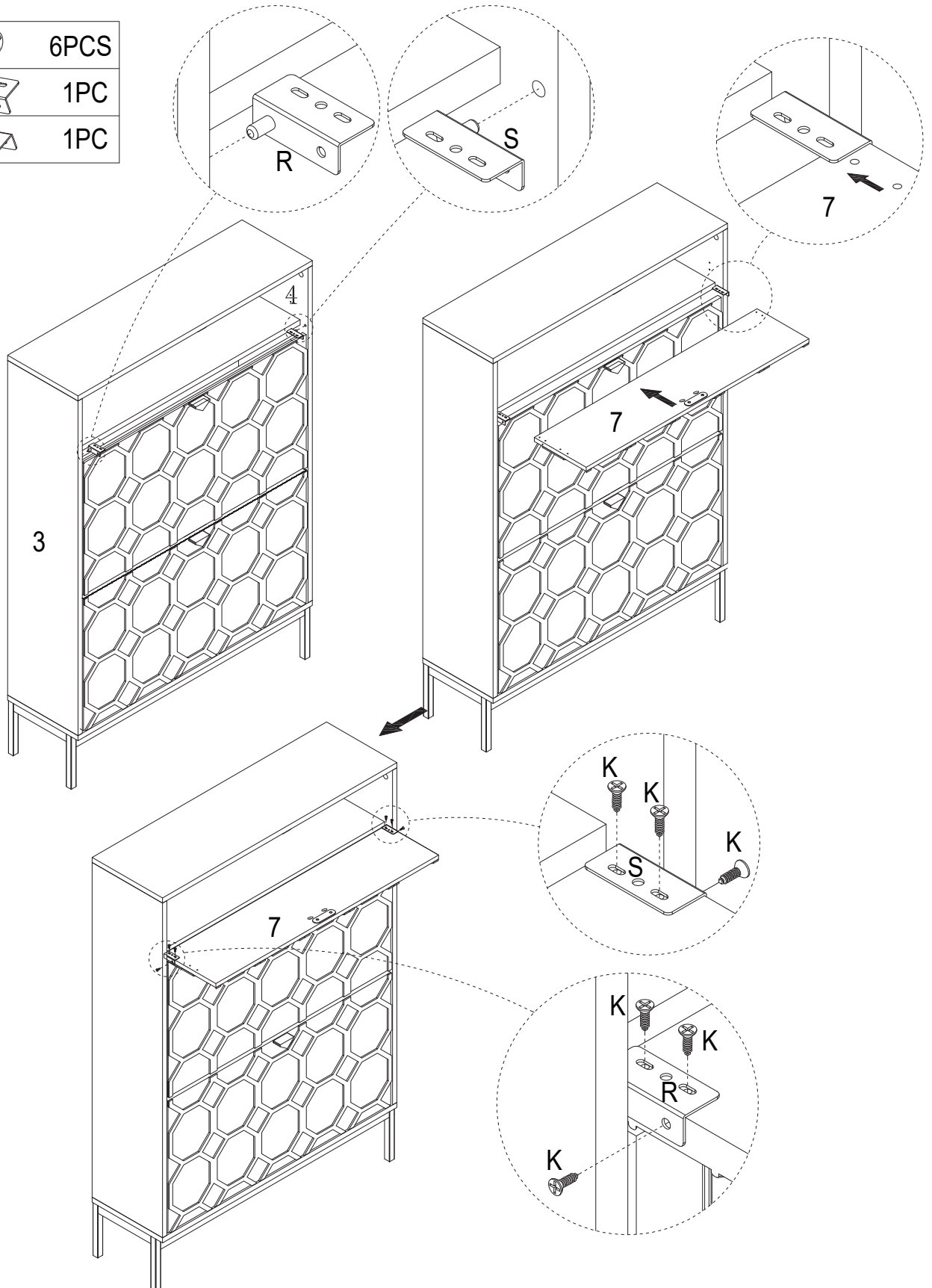

## STEP 11

K:		6PCS
R:		1PC
S:		1PC



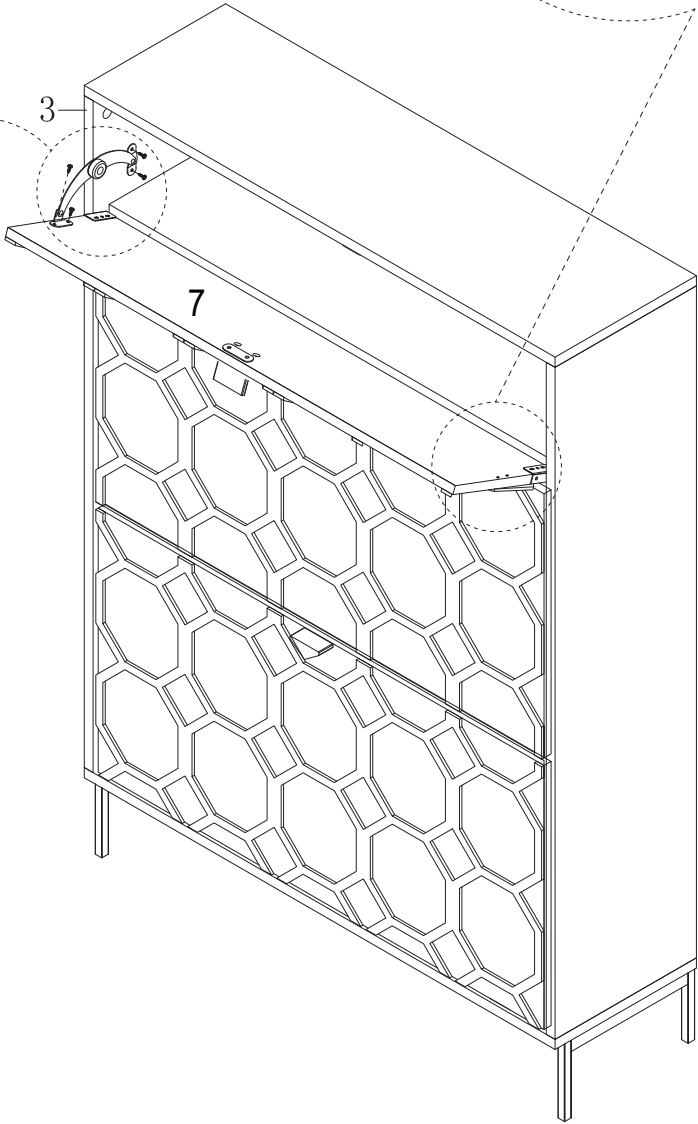
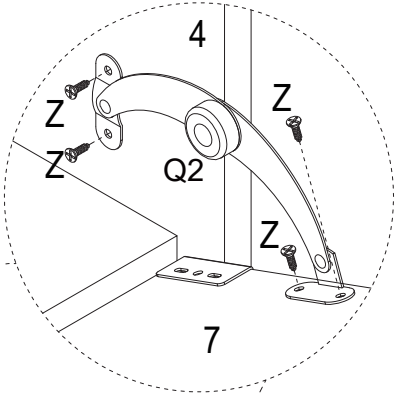
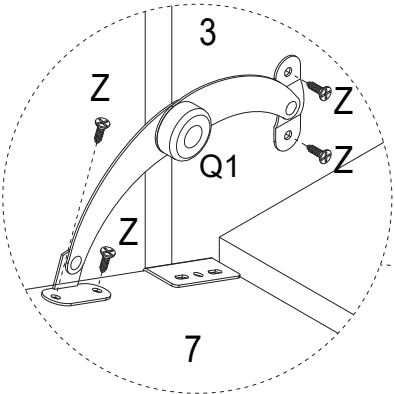

STEP 12

Z:		8PCS
Q:		1PC
Q:		1PC



## STEP 13

V:		2PCS
W:		2PCS
X:		2PCS

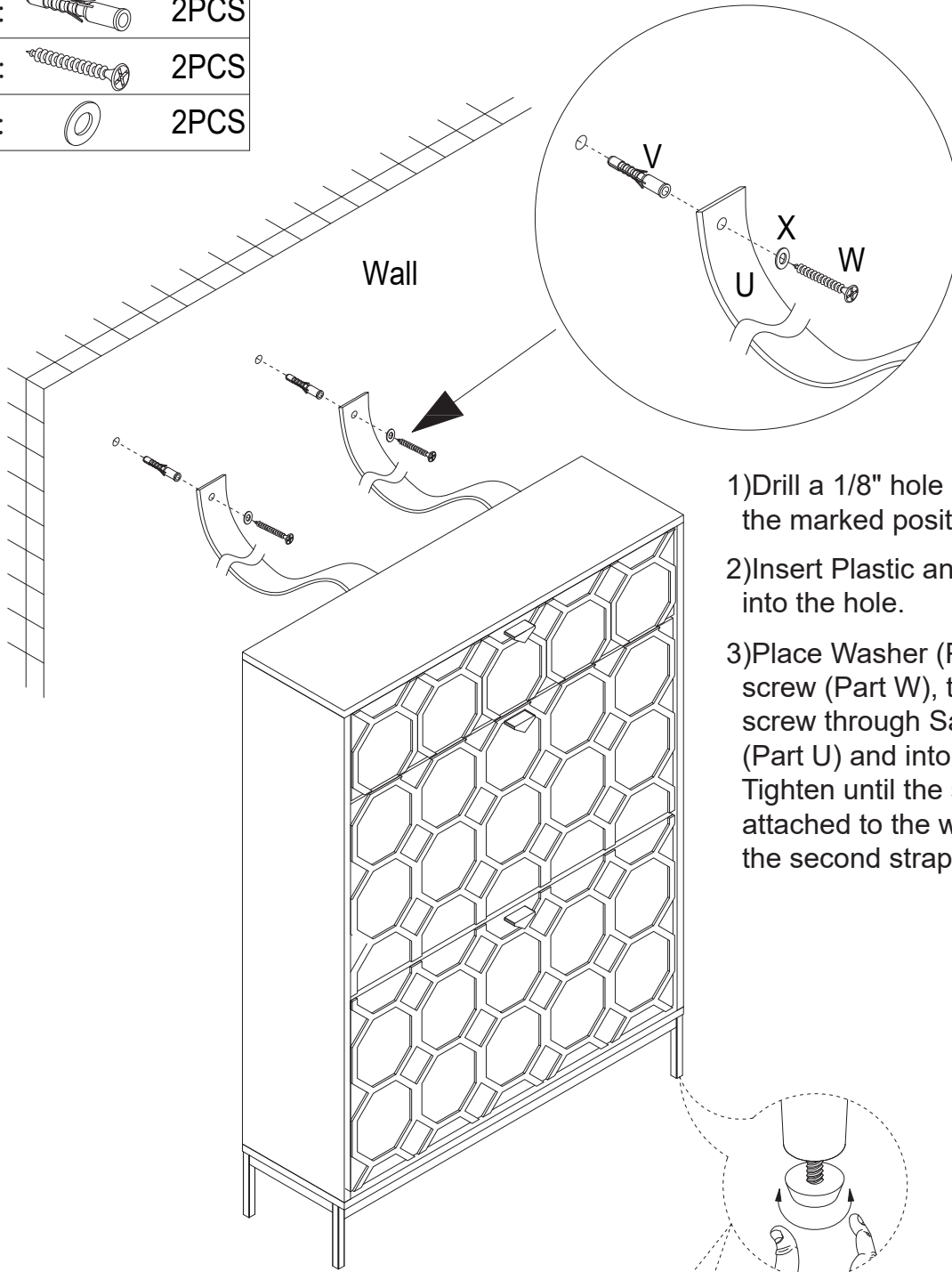

1) Drill a 1/8" hole into the wall at the marked position.

2) Insert Plastic anchor (Part V) into the hole.

3) Place Washer (Part X) over Mounting screw (Part W), then drive the screw through Safety wall strap (Part U) and into the anchor. Tighten until the strap is firmly attached to the wall. Repeat for the second strap.

Turn the adjustable feet (located at the base) clockwise/counterclockwise to level the cabinet; ensure all feet contact the floor to prevent wobbling.