

SOLAR WORKBENCH SHOP LIGHT

INSTALLATION, USAGE, & CARE GUIDE

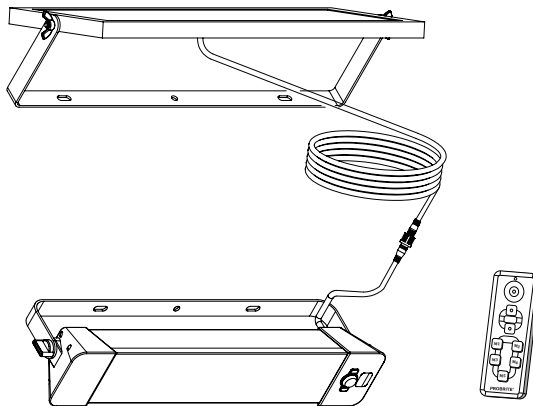

Questions? / Missing Parts? / Need Accessories?

Before returning to the store, call or email PROBRITE
Customer Service 9am-5pm EST Monday to Friday.

1-844-507-5651

support@PROBRITE.com

PROBRITE.COM

Visit us online anytime or call us to get information on our product range, download detailed spec & photometric files, find product and mounting accessories, view installation tutorials and videos, and learn about our DLC® rebate eligible products.

TABLE OF CONTENTS

Table of Contents	2	Installation	5
Safety Information	2	Wall Mount Installation.....	5
Pre-Installation	3	Solar Panel Installation.....	6
Planning Installation.....	3	Operation	7
Specifications.....	3	Care & Cleaning	9
Tools Required.....	4	Troubleshooting	10
Package Contents.....	4	Warranty	10
Hardware Included.....	4		

SAFETY INFORMATION

IMPORTANT

THIS PRODUCT MUST BE INSTALLED IN ACCORDANCE WITH THE APPLICABLE NATIONAL ELECTRICAL CODE AND LOCAL BUILDING CODES BY A PERSON FAMILIAR WITH THE CONSTRUCTION AND OPERATION OF THE PRODUCT AND THE HAZARDS INVOLVED.

PRECAUTIONS

- Please read and understand this entire manual before attempting to assemble, install, or operate this light fixture.
- This light fixture requires no power source other than included solar panel.
- Make sure connections are secure using intergral plug-and-tighten cable connectors.
- This light fixture should be installed outdoors to a wall or a wooden pole.
- This solar panel should be installed outdoors with direct sunlight access; Can be mounted on ground, wall or rooftop.

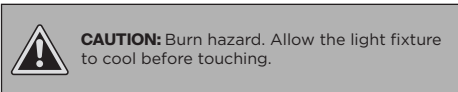
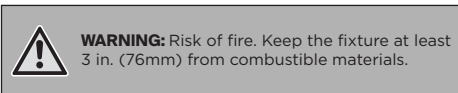

PRE-INSTALLATION

PLANNING INSTALLATION

Before installing the light fixture, ensure that all parts are present. Compare parts with the *Hardware Included* and *Package Contents* sections. If any part is missing or damaged, do not attempt to assemble, install, or operate this light fixture.

SPECIFICATIONS

MODEL	SQAD 30
Lumens (Light Output)	Up to 2400 Lumens
Max Watts	24 Watts
Lumens/Watts (Efficacy)	100 Lumens per Watt
Power Consumption	18 (M1) / 19 (M2) / 19 (M3) / 6 (M4) / 20 (M5)W (integral battery)
Battery Capacity	6.4V 6000mah
Charging	8 hrs (solar panel included)
Light Color (CCT)	5000K
Dimmable (Operated by Remote Control, Excluding mode 4/5)	20% / 40% / 60% / 80% / 100%
Operation Modes (Operated by Remote Control)	<p>Mode 1: 4Hr Mode</p> <ul style="list-style-type: none"> ● 200 Lumens for 4 hrs ● 2000 Lumens when motion detected <p>Mode 2: All-night Mode</p> <ul style="list-style-type: none"> ● 140 Lumens for 4 hrs ● 40 Lumens for 8 hrs ● 1300 Lumens when motion detected <p>Mode 3: Energy Saving Mode</p> <ul style="list-style-type: none"> ● 120 Lumens for 4 hrs ● 40 Lumens for 10 hrs ● 900 Lumens when motion detected <p>Mode 4: Motion-only</p> <ul style="list-style-type: none"> ● 2400 Lumens when motion detected <p>Mode 5: Occupancy Mode</p> <ul style="list-style-type: none"> ● First trigger: 1400 Lumens for 20 secs ● Second trigger: 900 Lumens for 30 mins ● Third trigger: 460 Lumens for 4 hrs

PRE-INSTALLATION

TOOLS REQUIRED

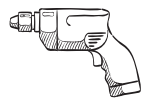

Power
Drill



Wrench



Ladder

PACKAGE CONTENTS

Part	Description	Quantity
A	Light fixture	1
B	Integral motion sensor	1
C	Solar panel	1
D	Remote control	1

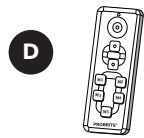

(Battery included)

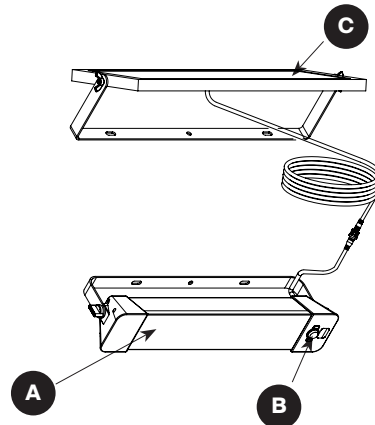

HARDWARE KIT



NOTE: Hardware *not* shown to actual size.

Part	Description	Quantity
AA	Hex head screws	8
BB	Wing nuts	2
CC	Spring lock washers	2
DD	Flat washers	2

AA



BB



CC



DD



WALL MOUNT INSTALLATION

1 FOR BEST RESULTS



CAUTION: Do not tamper with motion sensor as it is wired into fixture.

- When mounting the fixture, ensure the motion sensor (B) has clear line of sight to target area for motion detection.
- Ensure solar panel (C) has direct sunlight exposure.
- Do NOT connect fixture to any wires or power supply.
- Hardware provided to mount fixture to wood. Concrete walls will require alternate hardware (not included).

2 MOUNTING THE FIXTURE TO THE WALL

- Position the light against a wall and secure light fixture by tightening set hex head screw (AA).

(Fig 1).

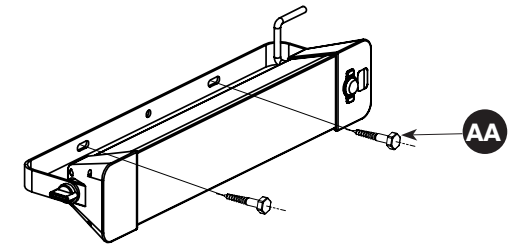

SOLAR PANEL INSTALLATION

3 MOUNT PANEL

- Mount bracket on the solar panel (C) to appropriate platform as shown in (Fig 2).



NOTE: Gasket Holes pre-drilled in bracket for ease of mounting).

- To adjust the angle of the solar panel, loosen the butterfly nuts on each side of the panel.
- Once aimed, tighten the butterfly nuts to lock the solar panel position.
- Plug the connector of the solar panel wire into the connector of the fixture wire and screw outer connector as shown in (Fig 3) to lock connectors together.

(Fig 2)

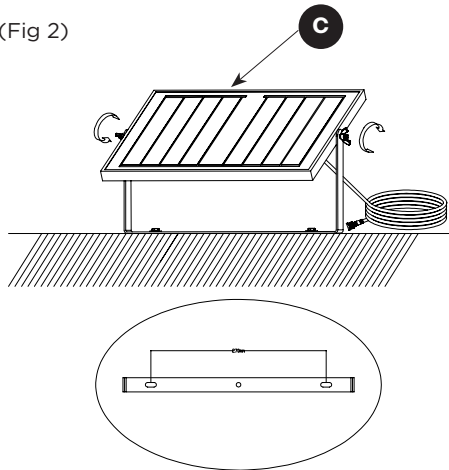

(Fig 3)

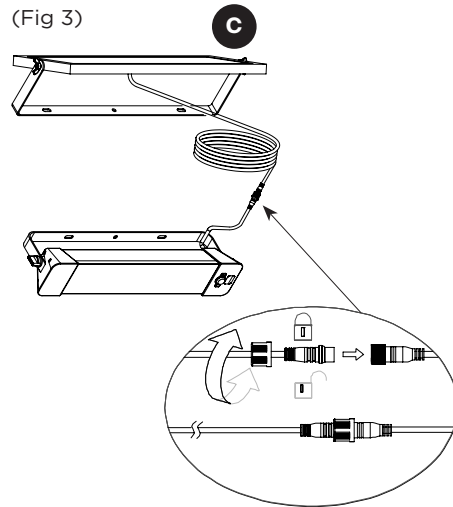

OPERATION

1 REMOTE CONTROL OPERATION

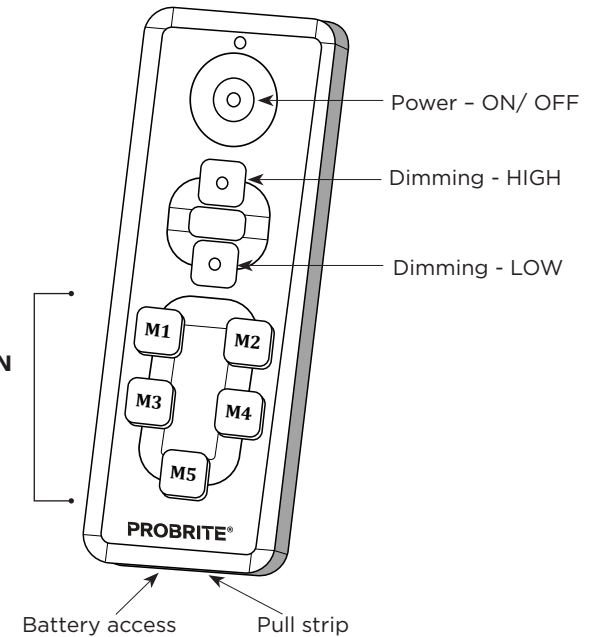

MODES OF OPERATION

(Operate at maximum of 25ft from the fixture)

SELECT MODE WITH REMOTE CONTROL

OPTION 1: 4 HOURS MODE (M1)

4 HOURS MODE enables the light fixture to turn ON for 4 hours at 200 lumens ambient light. Upon motion detection, light emits 2000 lumens for security lighting.

- Once this mode is selected it will remain in the current mode until the fixture is manually turned off through the remote control.
- Dimming will be proportionate to the lumens (200) in the selected mode, until the fixture is manually turned off or a new mode has been selected.

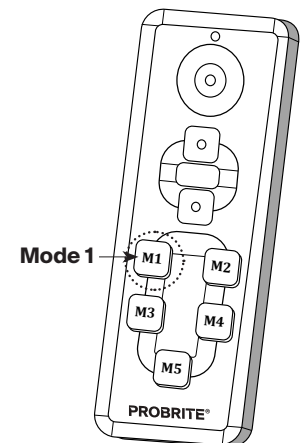

OPERATION (CONTINUED)

OPTION 2: ALL-NIGHT MODE (M2)

ALL-NIGHT MODE enables the light fixture to turn on for first 4 hours at 140 lumens, followed by 8 hours at 40 lumens for lighting through out the night Upon motion detection, light emits 1300 lumens.

- Once this mode is selected, it will remain in the current mode until the fixture is manually turned off through the remote control.
- Dimming will be proportionate to the lumens (140, 40) in the selected mode, until the fixture is manually turned off or a new mode has been selected.

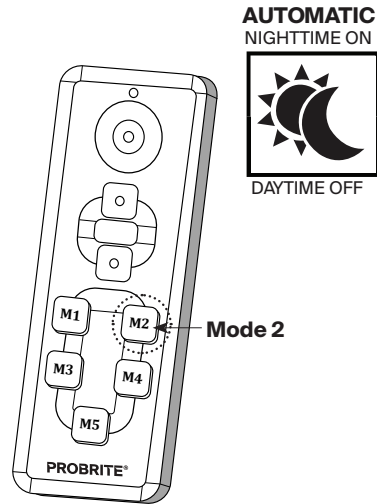

OPTION 3: ENERGY-SAVING MODE (M3)

ENERGY-SAVING MODE enables the light fixture to turn on for first 4 hours at 120 lumens, followed by 10 hours at 40 lumens to conserve the battery. Upon motion detection, light emits 900 lumens.

- Once this mode is selected, it will remain in the current mode until the fixture is manually turned off through the remote control.
- Dimming will be proportionate to the lumens (120, 40) in the selected mode, until the fixture is manually turned off or a new mode has been selected.

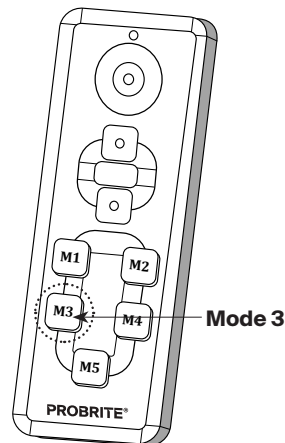

OPERATION (CONTINUED)

OPTION 4: MOTION-ONLY MODE (M4)

MOTION-ONLY MODE enables the light fixture to turn on ONLY when motion is detected. Upon motion detection, light emits 2400 lumens for maximum security lighting.

- Once this mode is selected, it will remain in the current mode until the fixture is manually turned off through the remote control.
- Dimming is unavailable in this mode.

OPTION 5: OCCUPANCY MODE (M5)

OCCUPANCY MODE enables the light fixture to turn on ONLY when motion is detected:

- 1st trigger: 1400 lumens for 20 seconds
- 2nd trigger: 900 lumens for 30 minutes
- 3rd trigger: 460 lumens for 4 hours
- Once this mode is selected, it will remain in the current mode until the fixture is manually turned off through the remote control.
- Dimming is unavailable in this mode.

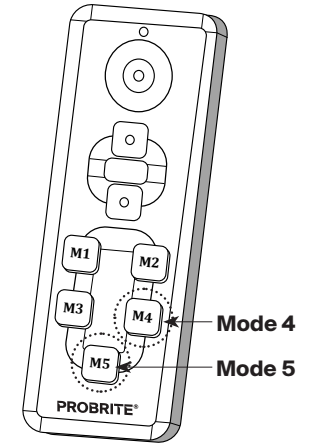

2 MANUAL OPERATION

ON-FIXTURE CONTROLS:

- Power - depress button on left of motion sensor for ON/OFF operation.
- Depress button on right of motion sensor for Mode. Continue pressing button until desired Mode is achieved.

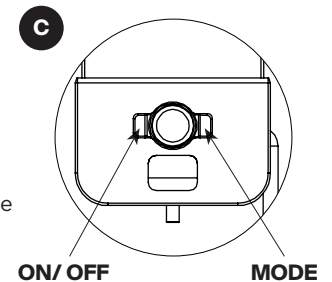

CARE AND CLEANING

- Clean the solar panel with clear water and a soft damp cloth on a regular basis to ensure batteries can fully charge.
- To prolong the original appearance of the light fixture clean with clear water and a soft, damp cloth only.
- Do not use abrasive cleaners or cleaners that contain alcohol. Do not apply paints, solvents, or any other chemicals on this light fixture. They could cause a premature deterioration of the finish and may void the warranty.
- Do not spray the light fixture with a hose or power washer.

TROUBLE SHOOTING

Problem	Possible Cause	Solution
Light does not turn ON	Low battery	Check the power meter on the integral motion sensor. If red, the battery needs to be charged for 8 hours before use. Check that cable connection is secure. Ensure the solar panel has exposure to sunlight and that there is no debris covering the solar panel.
	No motion detected	Check if the motion sensor is blocked by obstacle or dirt.
Remote control unresponsive	Low battery on the remote	Replace the battery cell (3V Lithium CRV2032) on the remote.
	Angle and distance	Turn the light OFF and ON under different angles and distances.
Light not bright enough	Wrong mode selected	Turn the light OFF and ON again to select a mode with higher output.
Light cycles ON and OFF continuously	Motion sensor is faulty	Clean the motion sensor with a damp, clean cloth. If the problem persists, please contact customer service.

LIMITED WARRANTY

This is a limited warranty offered by Probrite for one year from the date of purchase to its customers. Probrite warrants to customers that the product will be free from defects in material and workmanship. The obligation of Probrite under this warranty is limited to the provision of replacement of product and is extended to the original purchaser of the product on presenting valid purchase receipt or other proof of date of original purchase acceptable to Probrite. The receipt is required for rendering the warranty performance. Any warranty claims without original proof of purchase would not be accepted.

It should be noted that the warranty does not apply to Probrite products that have been altered or repaired by unauthorized personnel, have been subjected to neglect, abuse, misuse or accident or damages caused during shipping. Any other products not manufactured by Probrite which have been supplied, installed and/or used in conjunction with Probrite products are not covered under this warranty. Any damages caused by replacements bulbs, LEDs or corrosion or discoloration of brass components are also not covered by this warranty.

LIMITATION OF LIABILITY:

In no event Probrite shall be liable for indirect, consequential, incidental or special damages, or lost profits. Probrite is not liable for any claims or damage arising out of or connected with the manufacture, sale, delivery, use, maintenance and repair or modification of Probrite products, or supply of any replacement parts that exceed the purchase price of Probrite products, giving rise to a claim. Labor charges to remove or install the fixtures will not be accepted.

TO CLAIM:

Please contact PROBRITE customer service at 1-844-507-5651 or email support@PROBRITE.com and include your name, address and contact number, along with a copy of the purchase receipt and a brief description of the problem.

PROBRITE™

Questions? / Problems? / Missing Parts? / Need Accessories?

Before returning to the store, call or email PROBRITE
Customer Service 9am-5pm EST Monday to Friday.

1-844-507-5651

support@PROBRITE.com

PROBRITE.COM

RETAIN THIS MANUAL FOR FUTURE USE

Para las traducciones en español,
visit www.probrite.com/install