

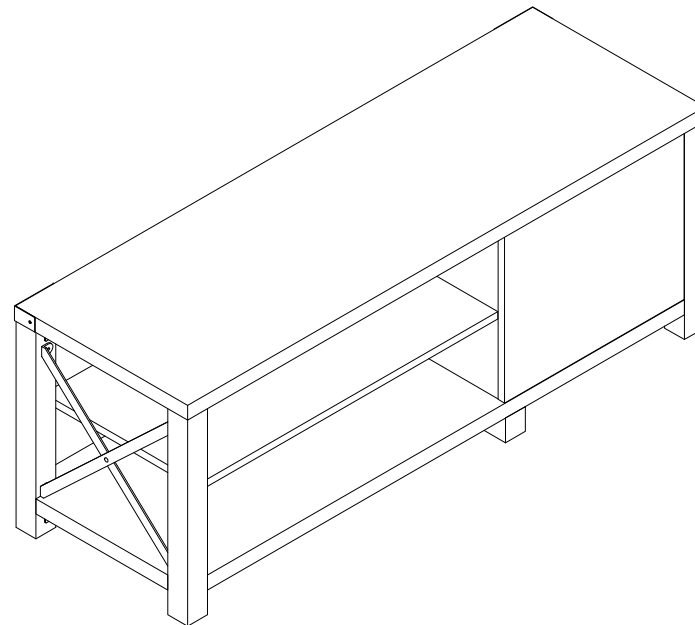

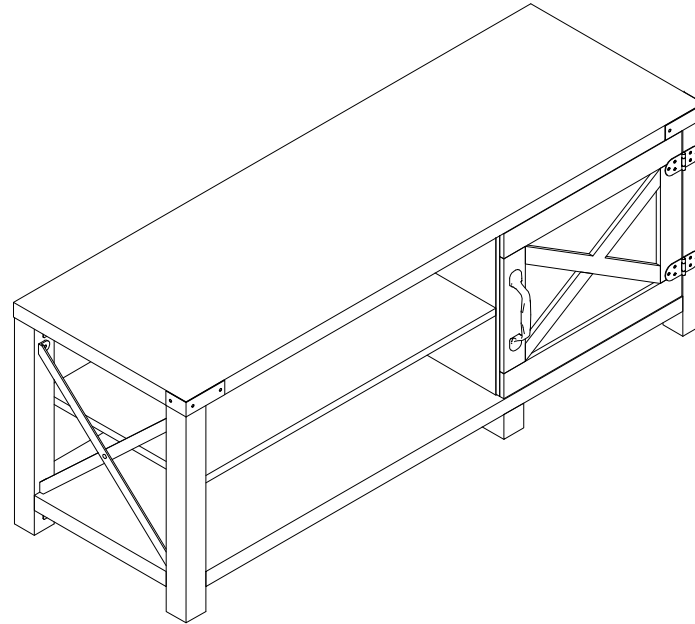

User Manual

ASSEMBLY INSTRUCTION

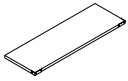
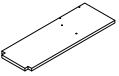
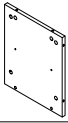
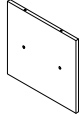
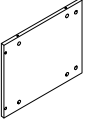
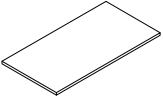

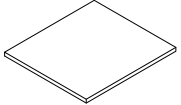
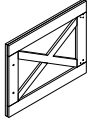
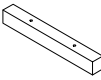











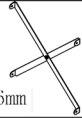

Parts List

NO.	Drawing	Dimension	QTY
1		1200*400*30mm	1
2		1152*398*30mm	1
3		366*306*15mm	1
4		335*364*15mm	1
5		416*335*15mm	1
6		691*362*15mm	1

NO.	Drawing	Dimension	QTY
7		398*362*15mm	1
8		413*331*18mm	1
9		398*46*50mm	1
10		415*46*46mm	1
11		415*46*46mm	1
12		415*46*46mm	1
13		415*46*46mm	1

Hardware Fitting

NO.	Drawing	QTY
A		26
B		26
C		4
D	 6*6mm	2
E	 3.5*14mm	28
F	 300*306mm	1
G	 8*40mm	2

NO.	Drawing	QTY
H		1
I	 6*55mm	2
J	 5mm	4
K		2
L	 3.5*14mm	12
M		1
N	 4*20mm	2
		1



Cam Coupling Using Methods

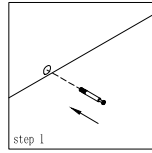

Step1.

Connect the cam coupling A as directed in the assembly instructions using hand.

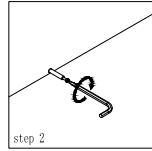

Step2.

Screw the cam coupling A as directed in the assembly instructions.

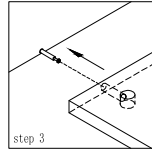

Step3.

Push the cam coupling A into the entry hole.

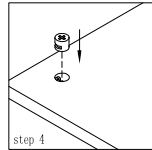

Step4.

Insert the cam coupling B as shown in the instructions.

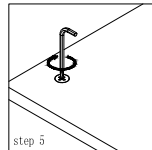

Step5.

Turn the cam coupling B clockwise with a screwdriver

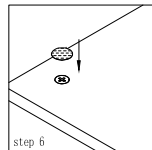

Step6.

Put on Beautycam.

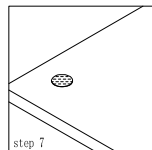



Step7.

Finished.

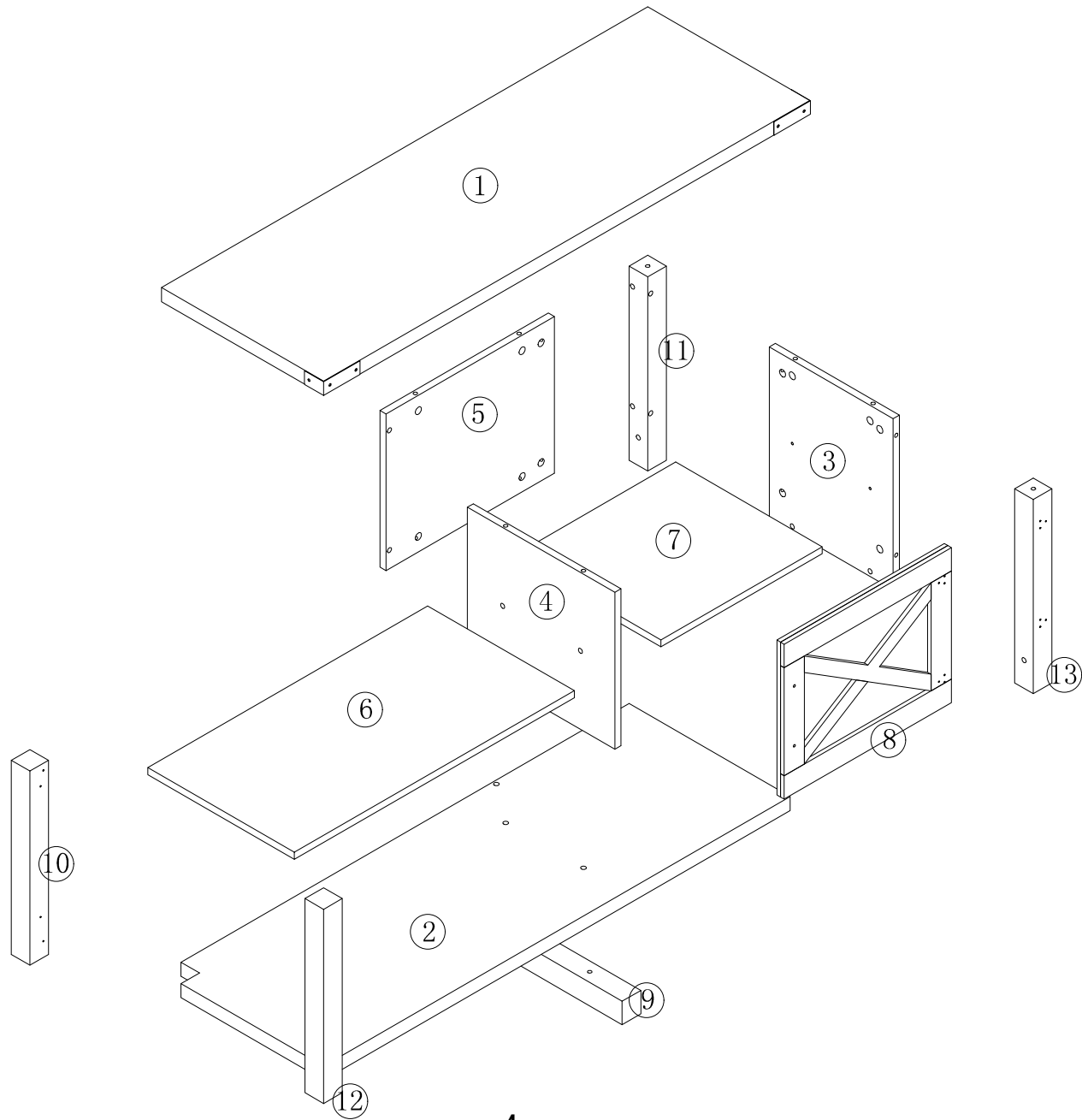

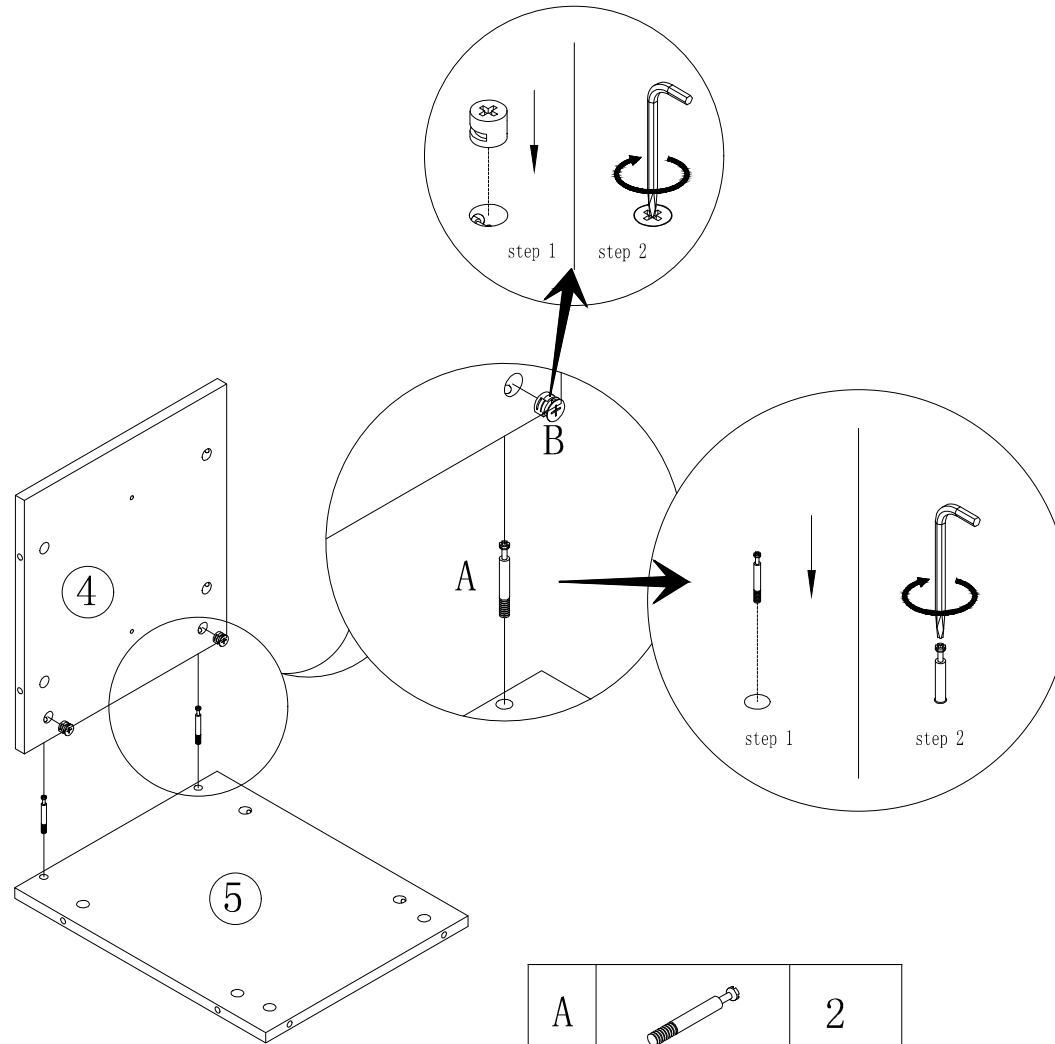
You should feel a click when the camlock is locked in place.
The joint is now secure.

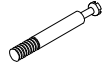



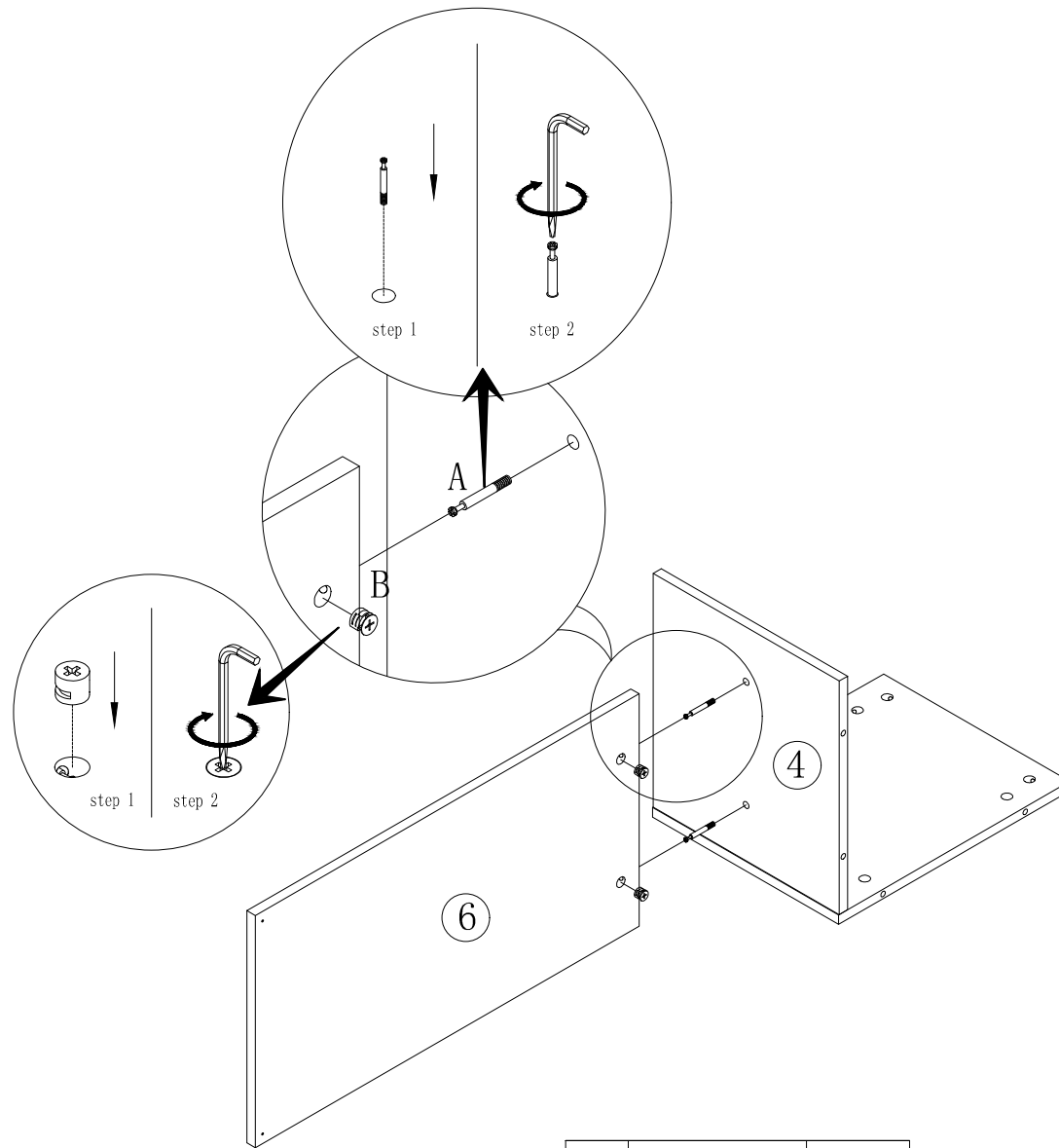

A		2
B		2

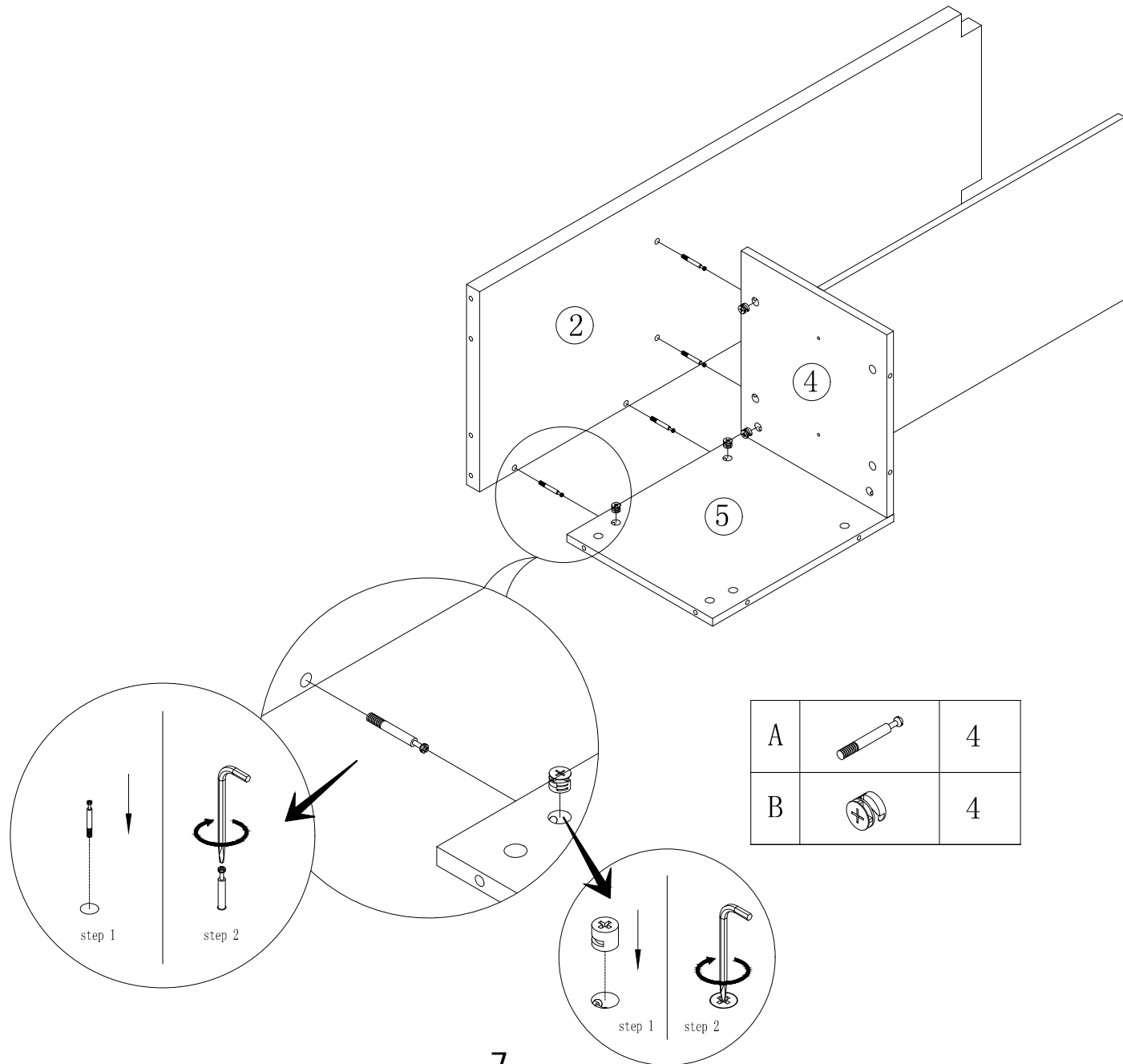

A		2
B		2

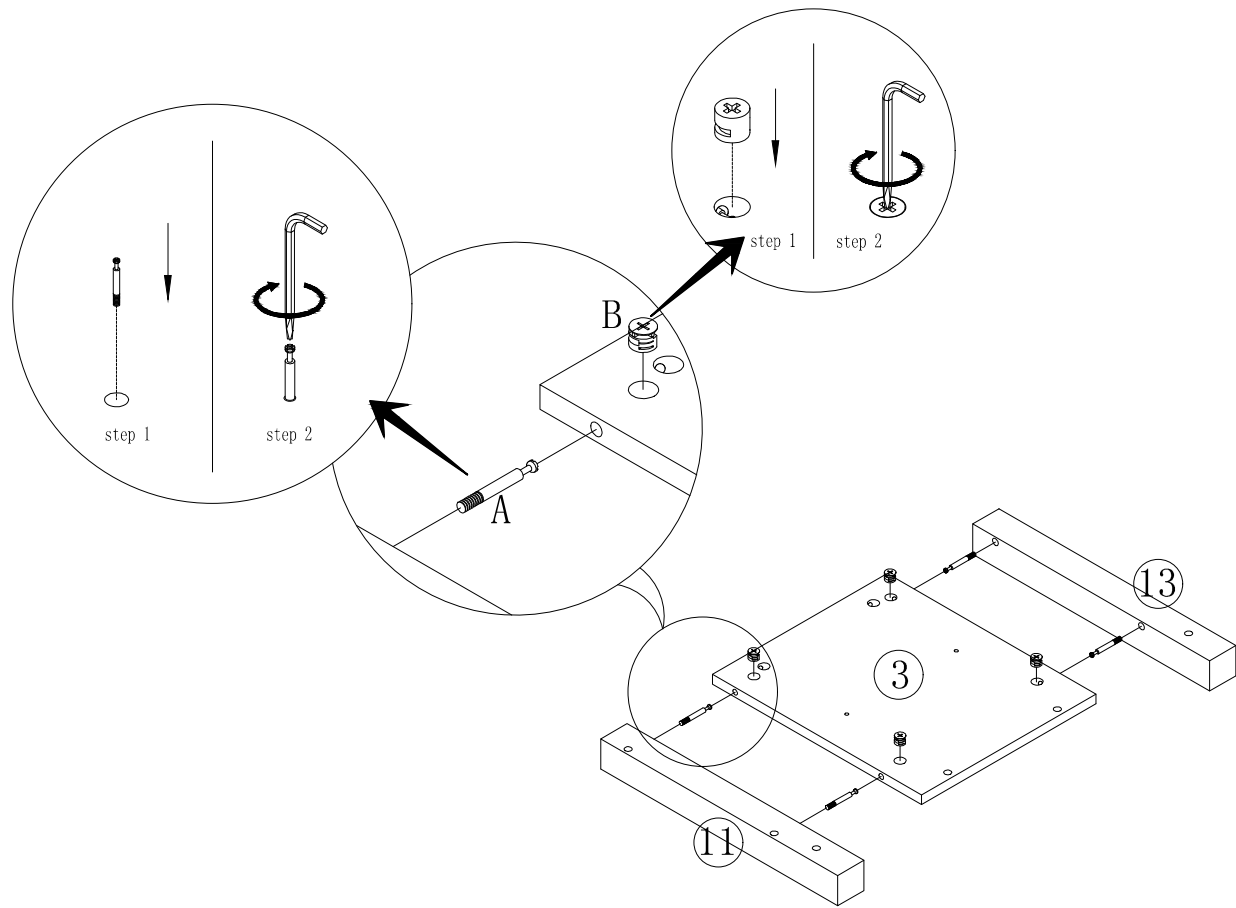



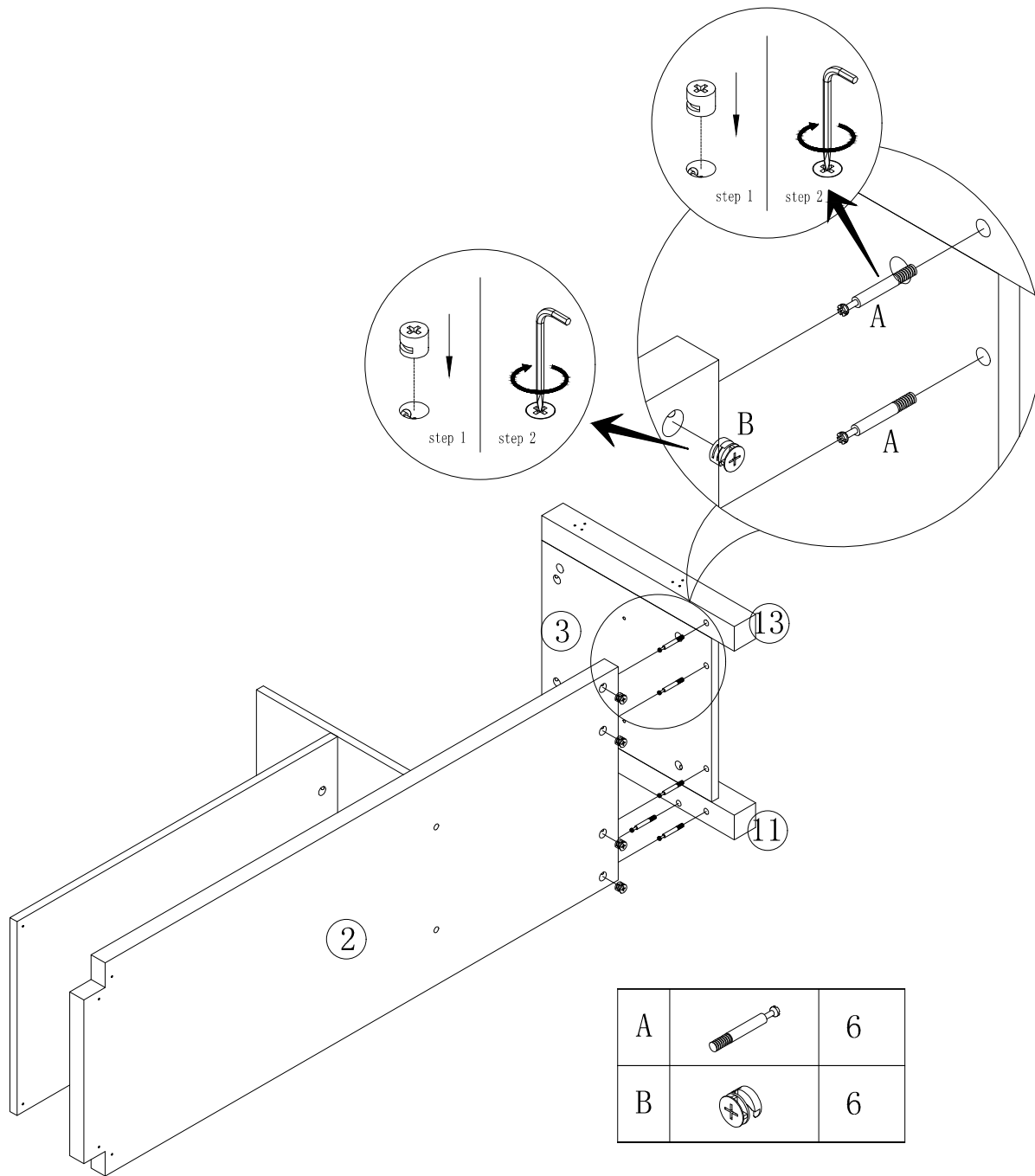

A		4
B		4

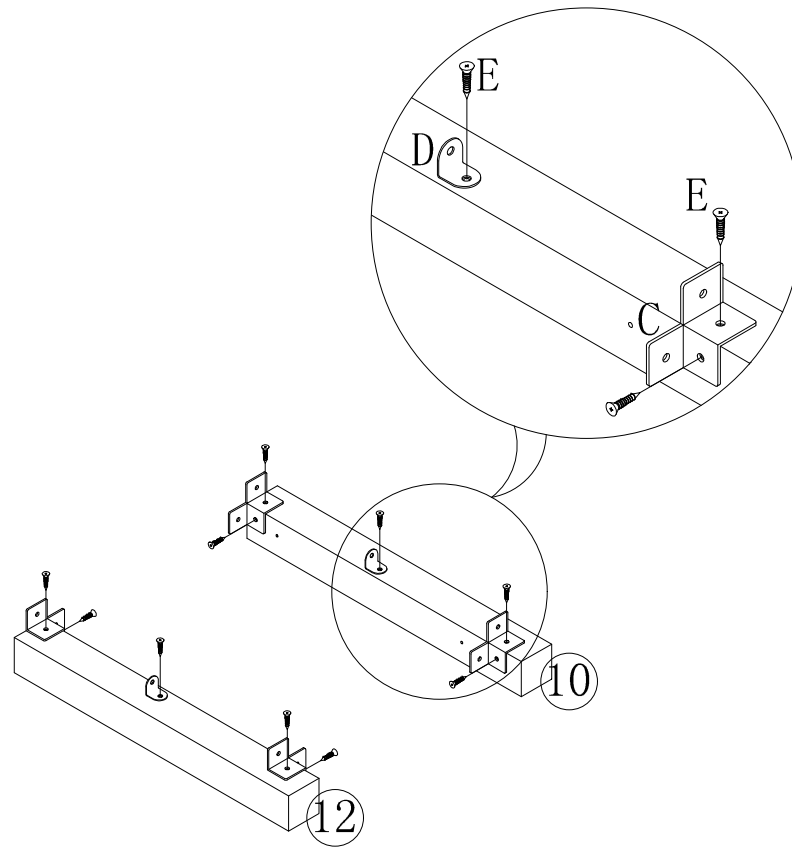





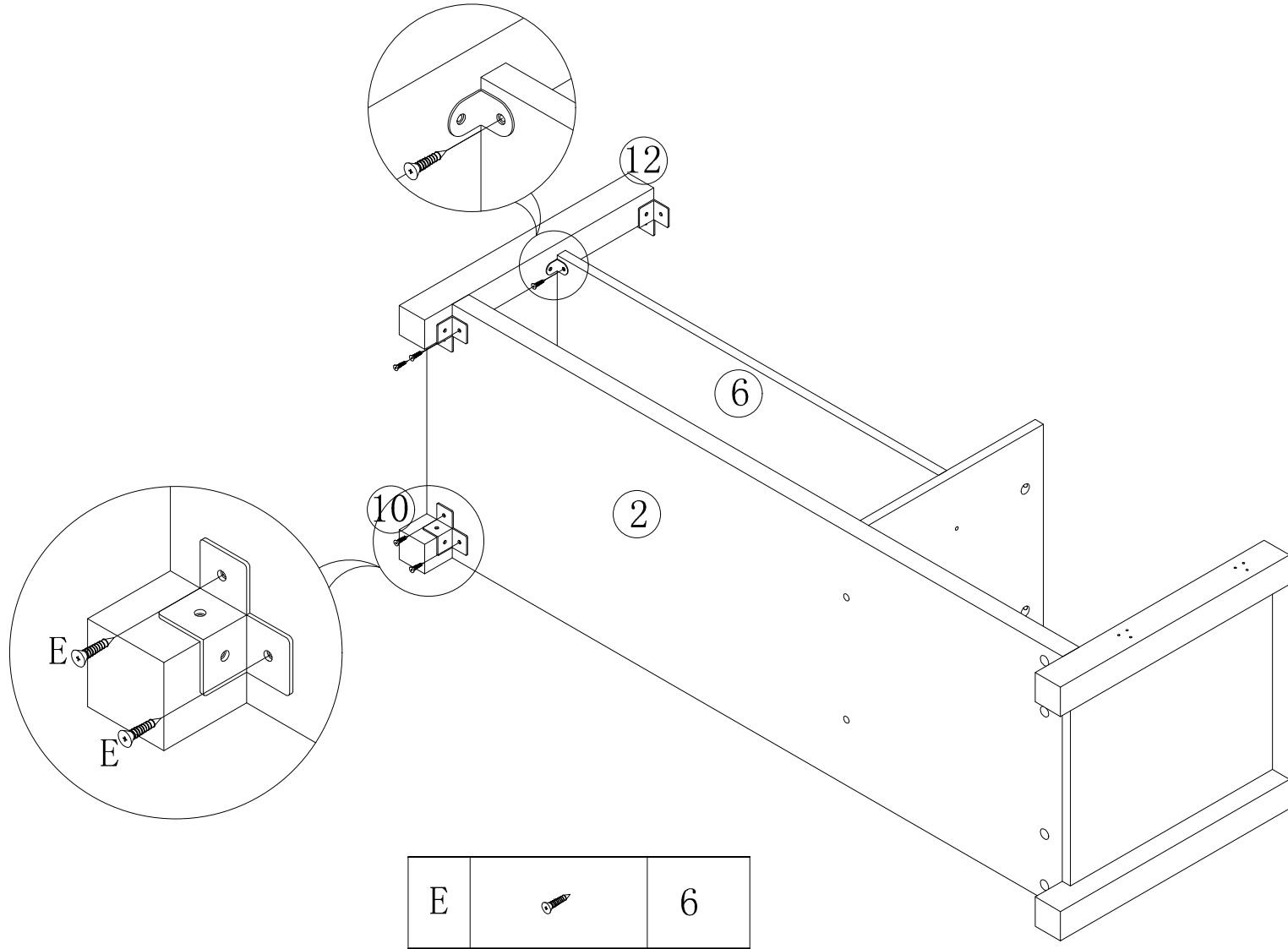

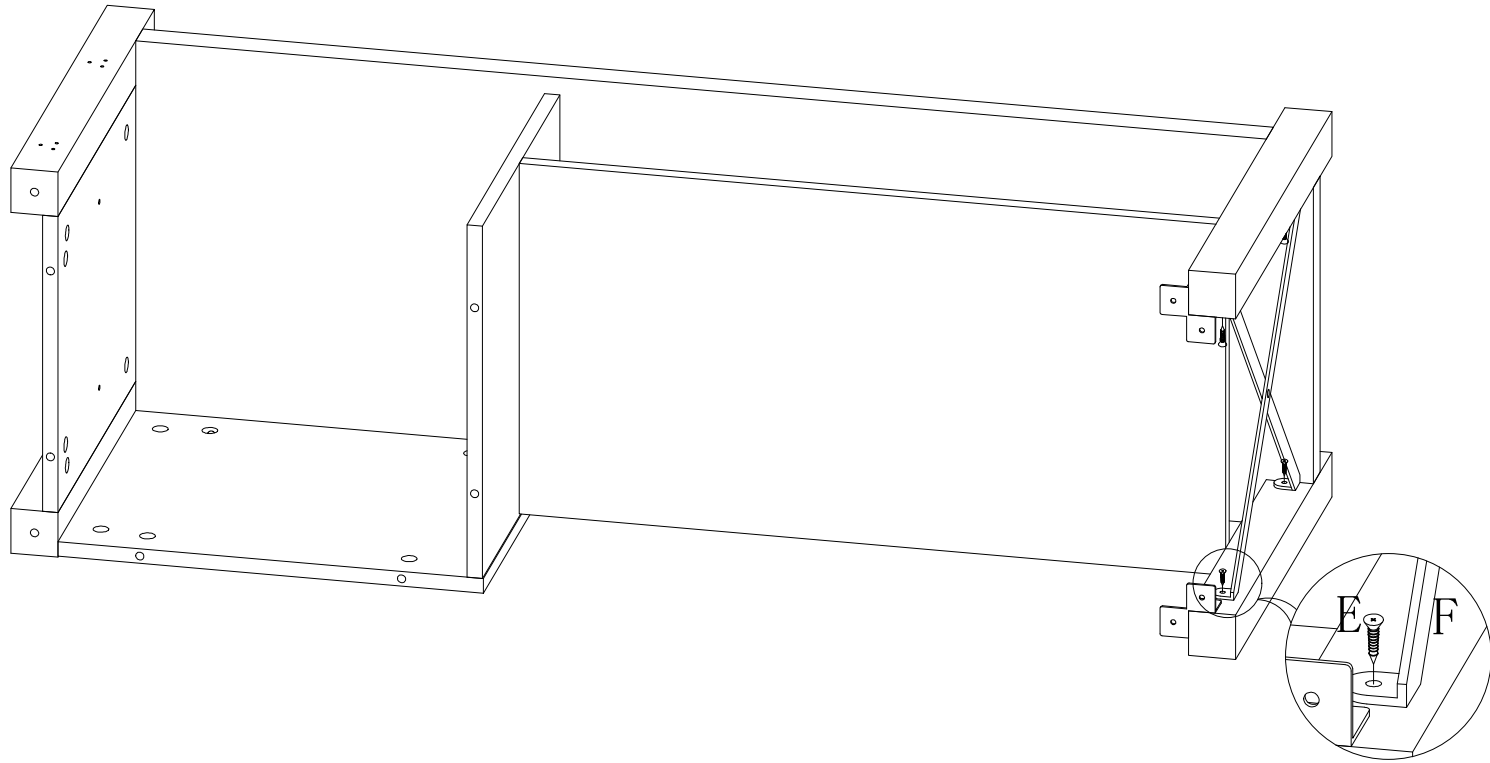

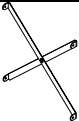
C		4
D		2
E		10

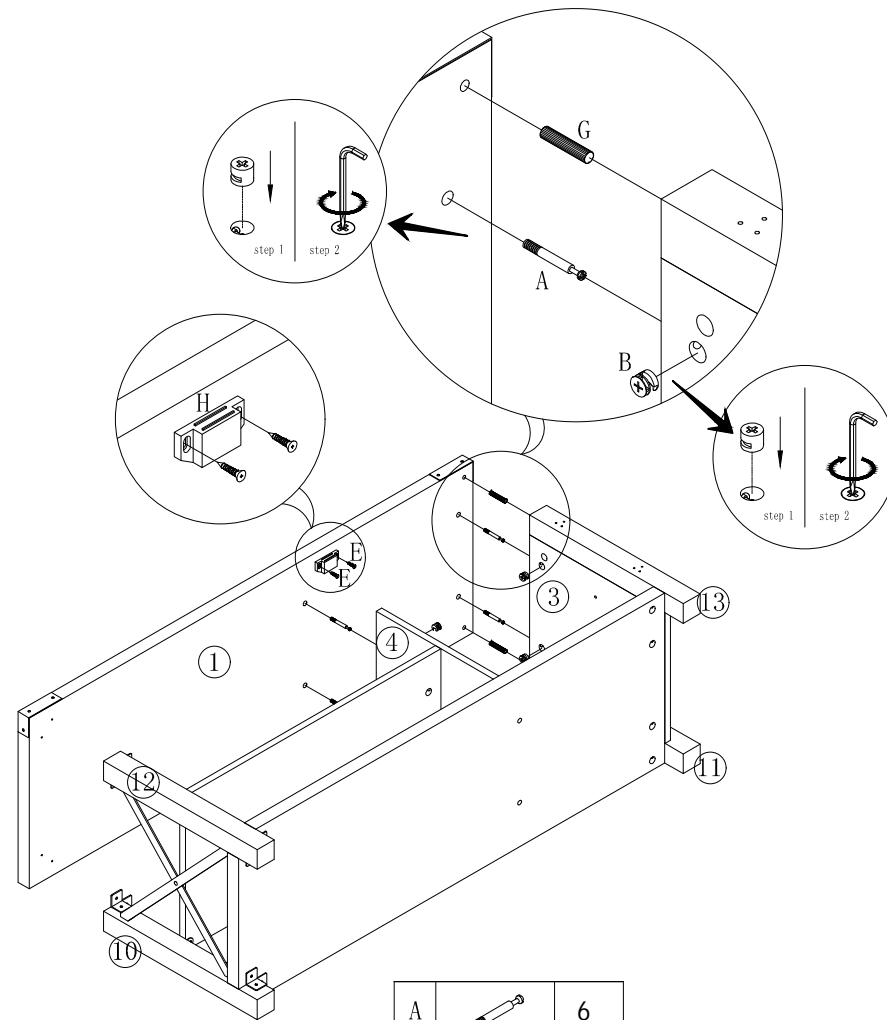





E		4
F		1

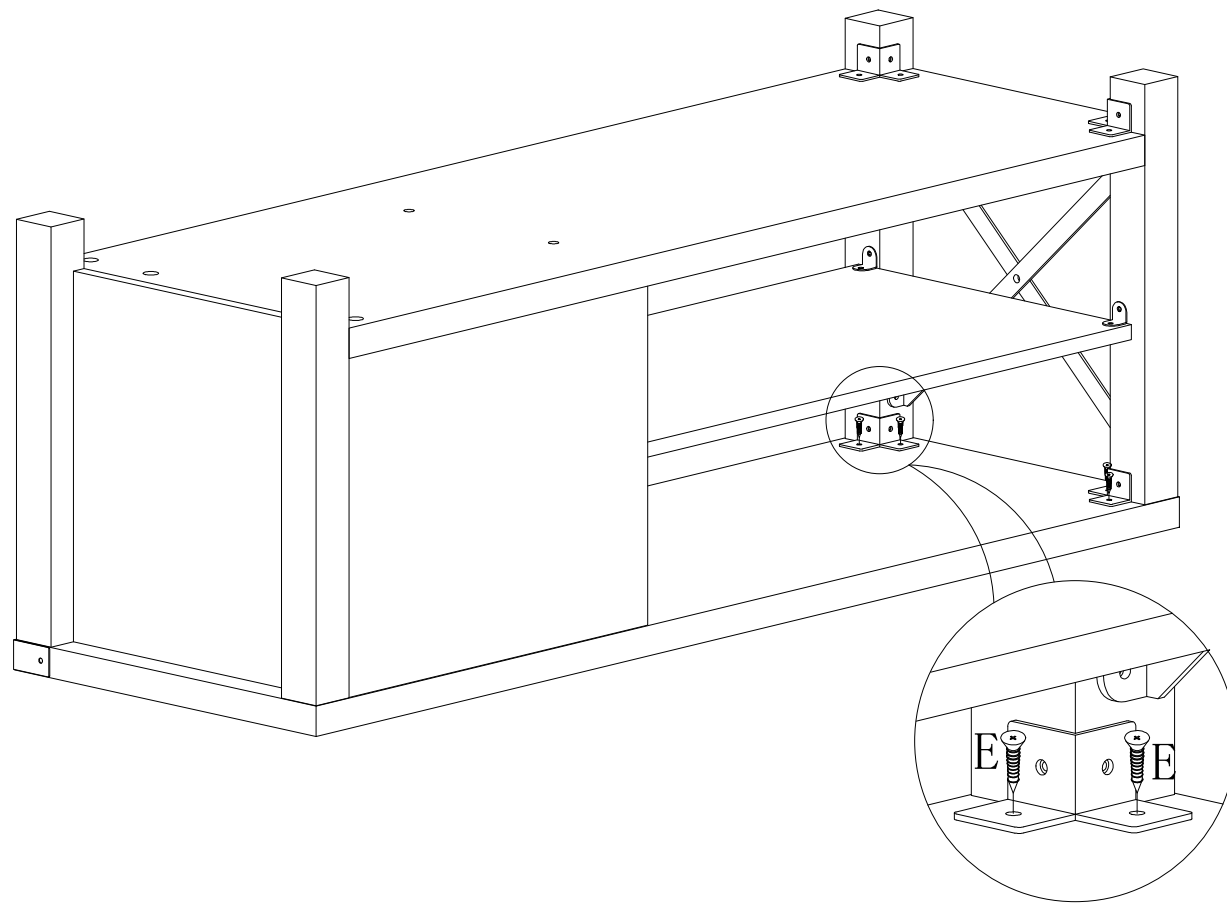

A		6
B		6
G		2
H		1
E		2



E		4
---	---	---

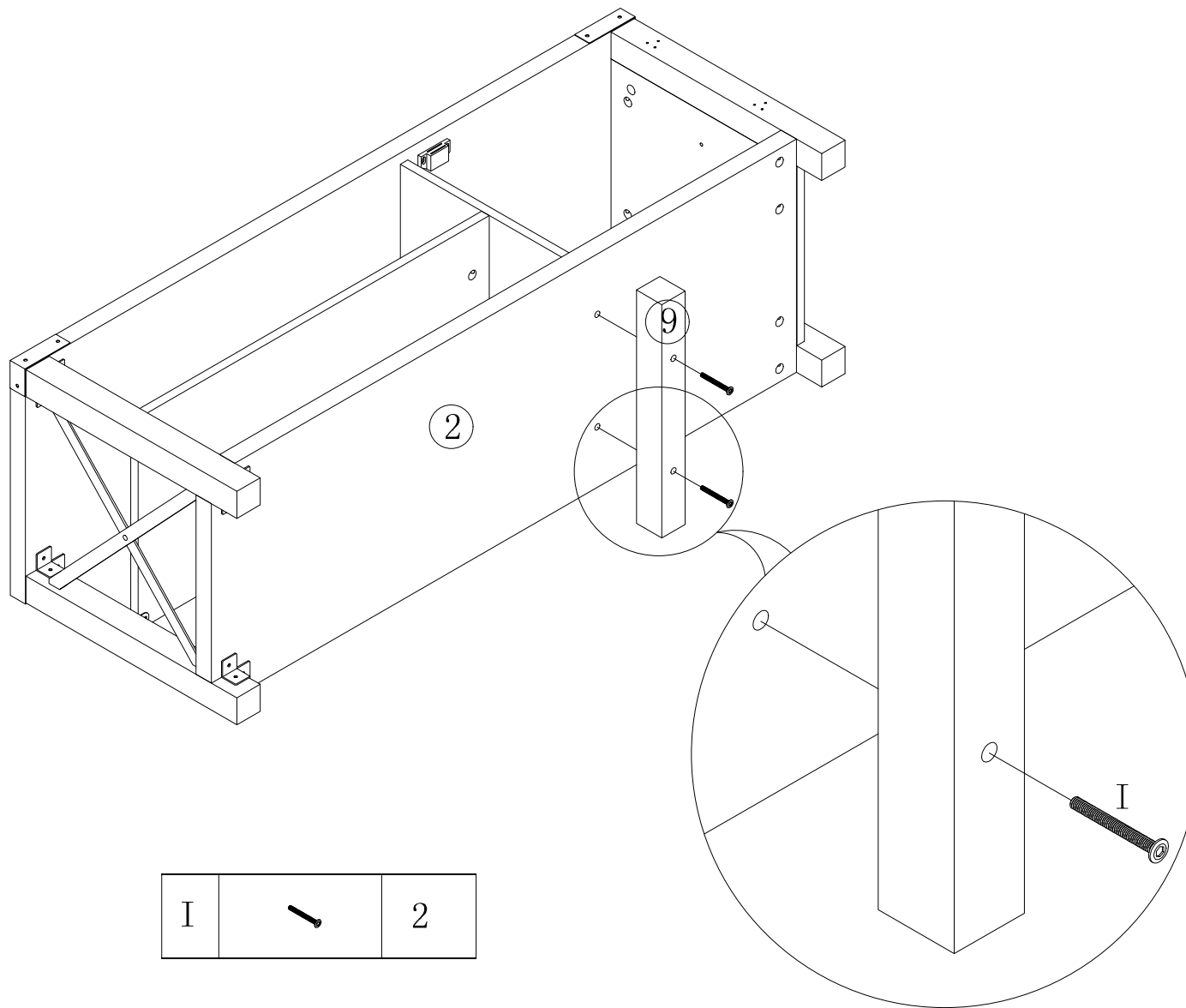

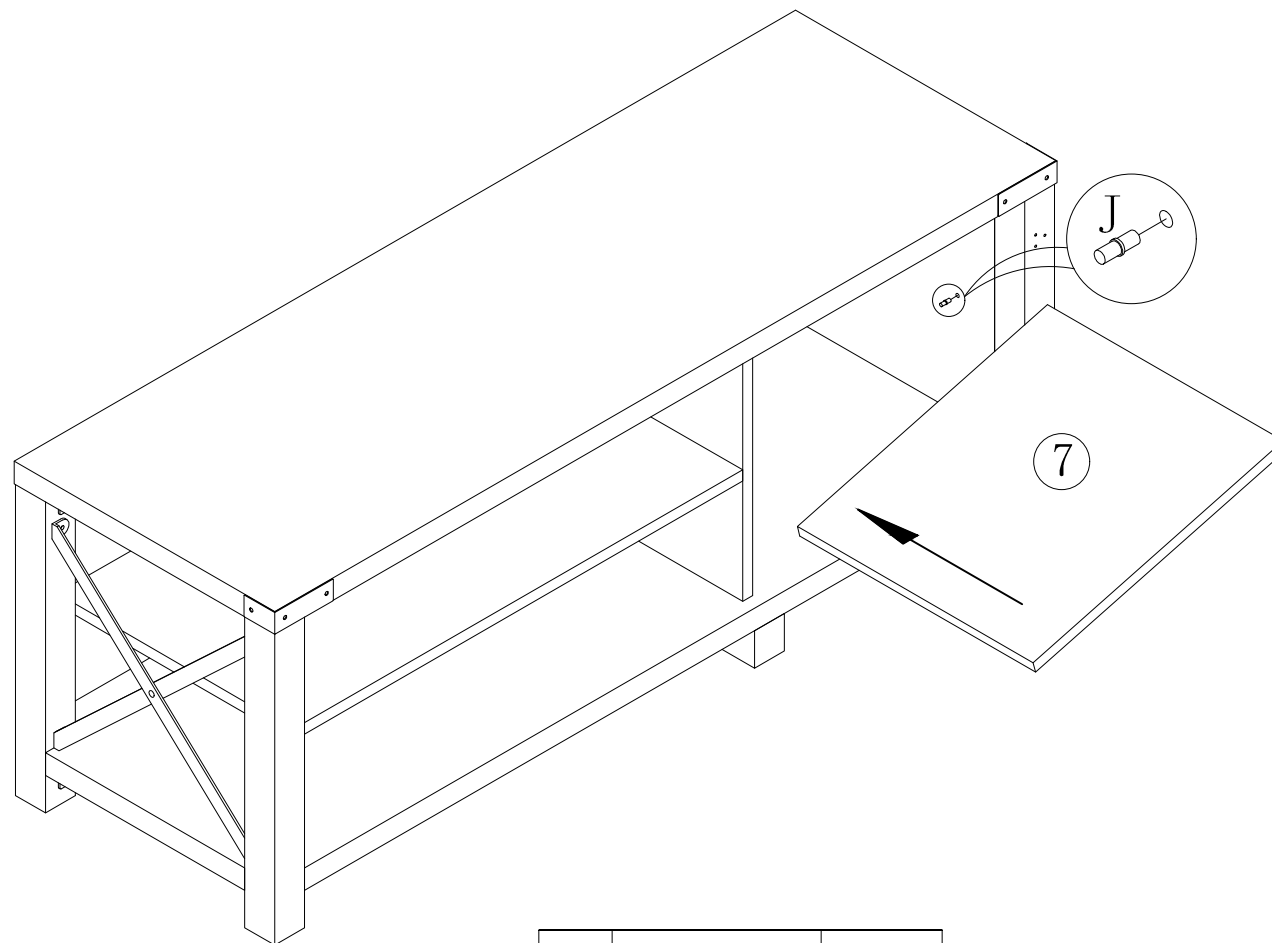

I		2
---	---	---



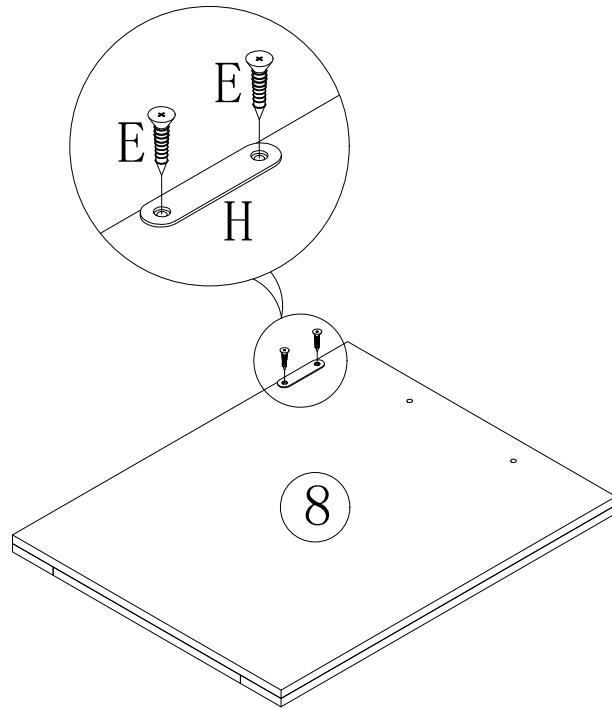

J		4
---	---	---



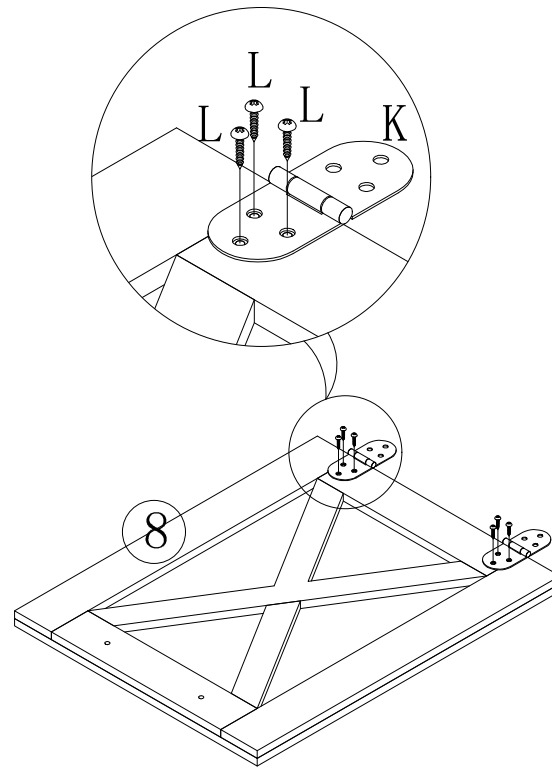

H		1
E		2

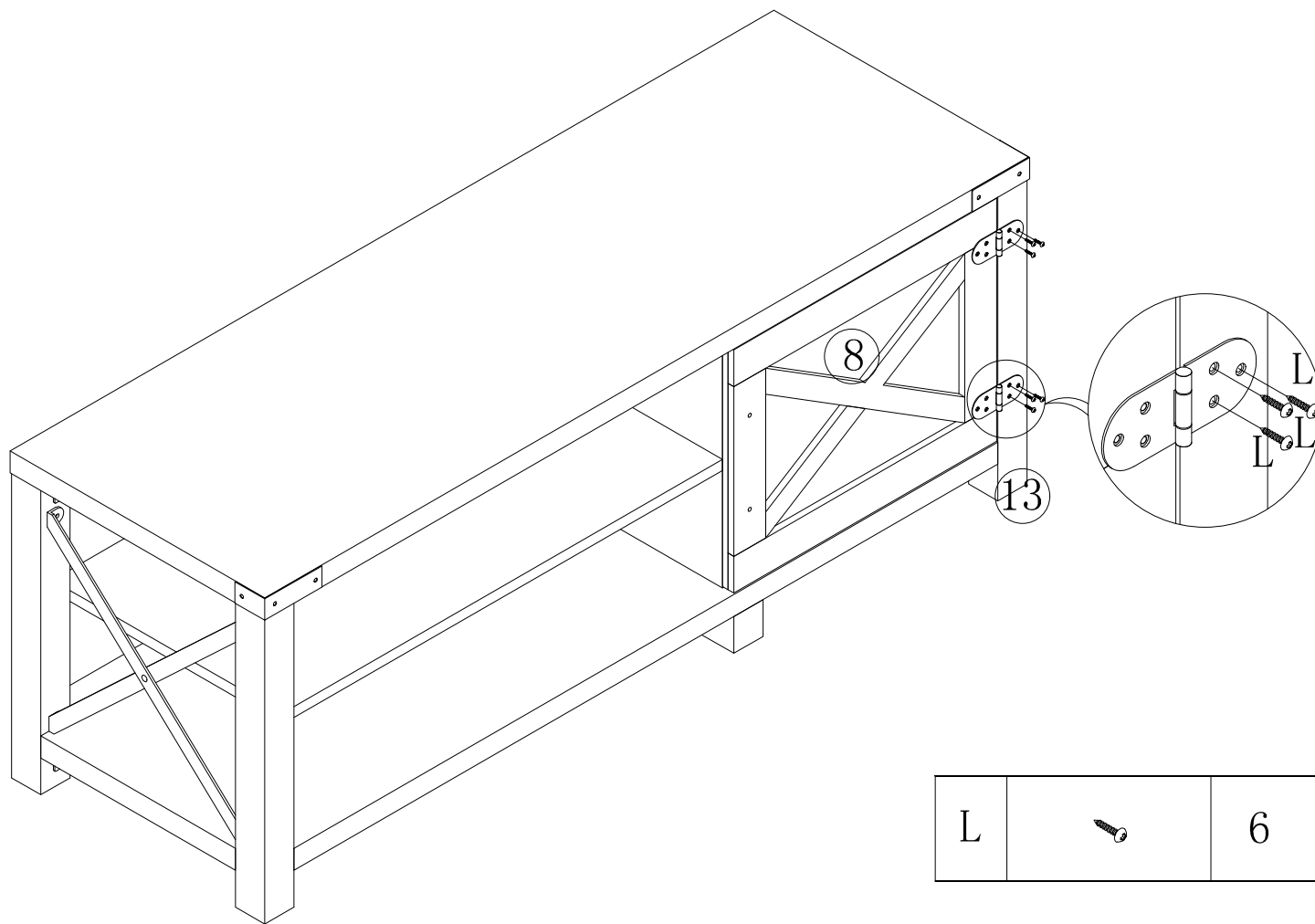

K		2
L		6

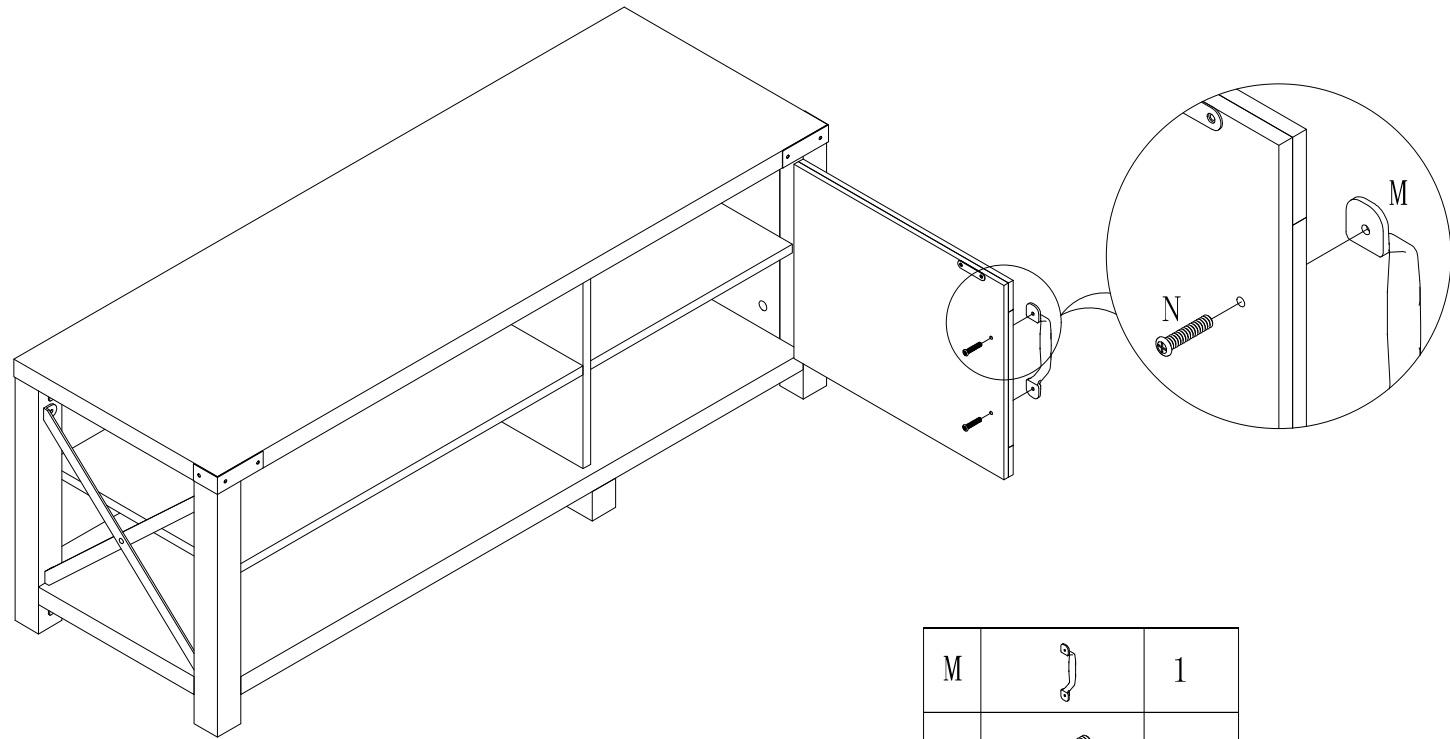



M		1
N		2

