

Installationsanleitung/Installation Instruction/Instruction d'installation
Istruzioni di installazione/Instrucciones de instalación
Esstisch-N620P355731/N620P355732

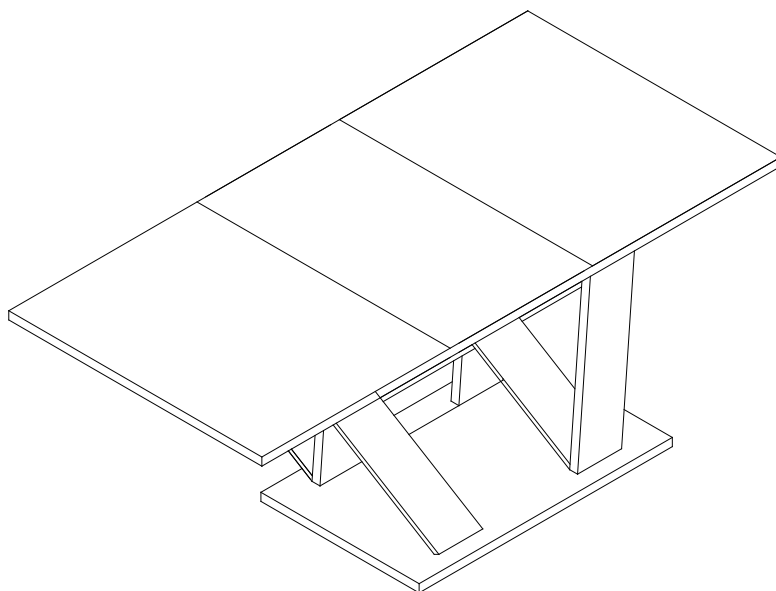

DE: Unser Produkt wird Ihnen in 2 Paketen geliefert. Die Lieferzeiten dieser 2 Pakete können abweichen, bitte haben Sie etwas Geduld und vielen Dank für Ihr Verständnis.

UK: Our product will be delivered to you in 2 packages. The delivery times of these 2 packages may differ, please be patient and thank you for your understanding.

FR: Notre produit vous sera livré en 2 colis. Les délais de livraison de ces 2 colis peuvent différer, soyez patient et merci pour votre compréhension.

IT: Il nostro prodotto verrà consegnato in 2 pacchi. I tempi di consegna di questi 2 pacchi possono variare; vi preghiamo di avere un po' di pazienza e vi ringraziamo per la vostra comprensione.

ES: Nuestro producto se entregará en 2 paquetes. Los tiempos de entrega de estos 2 paquetes pueden variar; por favor, tenga un poco de paciencia y gracias por su comprensión.

Installatie-instructies/Installationsanvisningar/Instrukcje instalacji

NL: Ons product wordt in 2 pakketten bij u geleverd. De levertijden van deze 2 pakketten kunnen verschillen, we vragen om uw geduld en bedanken u voor uw begrip.

SE: Vår produkt kommer att levereras till dig i 2 paket. Leveranstiderna för dessa 2 paket kan variera, vi ber om ditt tålamod och tackar för din förståelse.

PL: Nasz produkt zostanie dostarczony w 2 paczkach. Czas dostawy tych 2 paczek może się różnić, prosimy o cierpliwość i dziękujemy za zrozumienie.

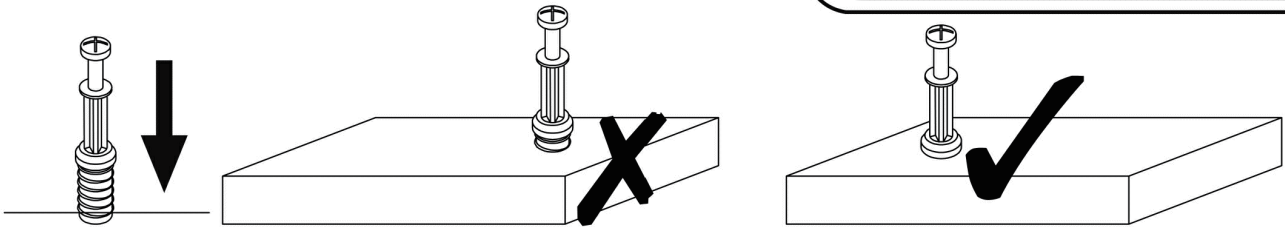

EN_QUICKFIT: Tighten quickfit until shoulder is flush with panel. Do not overtighten or undertighten.

FR_RACCORD RAPIDE: Faites serrer le raccord rapide jusqu'à ce que l'épaulement soit parfaitement encastré dans le panneau. Il ne faut ni trop serrer ni insuffisamment serrer.

ES_QUICKFIT: Apriete quickfit hasta que el hombro se descargue con el panel. NO lo sobreapriete ni lo apriete poco.

DE_QUICKFIT: Ziehen Sie den Quickfit fest, bis die Schulter mit der Platte bündig ist. Bitte nicht zu fest oder zu schwach anziehen.

IT_MONTAGGIO RAPIDO: Stringere il montaggio rapido fino a quando la spalla è a filo con il pannello, non stringere troppo o troppo poco.

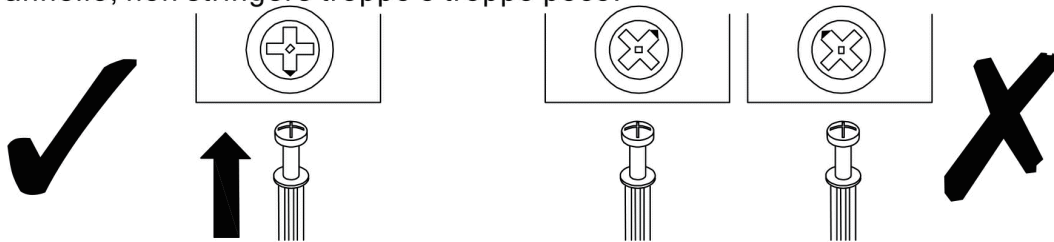

EN_CAM LOCK: When fitting cam lock, ensure starting position is correct before you insert connecting quickfit.

FR_SERRURE BATTEUSE: Avant d'insérer la serrure batteuse, veillez à la bonne orientation avant d'insérer le raccord rapide.

ES_CIERRE DE LA CÁMARA: Cuando instale el cierre de la cámara, asegúrese de que la posición de inicio es correcta antes de que inserte el quickfit conector.

DE_CAM-LOCK: Achten Sie bei der Montage des Cam-Locks auf die richtige Ausgangsposition, bevor Sie den Quickfit einsetzen.

IT_BLOCCAGGIO A CAMMA: Quando si monta il bloccaggio a camma, assicurarsi che la posizione iniziale sia corretta prima di inserire il montaggio rapido di collegamento.

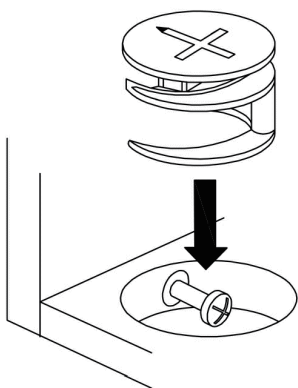

EN_Quickfit head should be in the centre of the cam lock when the two panels are joined.

Cam lock should be inserted before quickfit.

FR_Lorsque les deux panneaux sont assemblés, la tête du raccord rapide doit reposer au centre de la serrure batteuse.

Il faut insérer la serrure batteuse avant le raccord rapide.

ES_El cabezal del quickfit debe estar en el centro del cierre de la cámara cuando se unan los dos paneles.

Se debe insertar el cierre de la cámara antes que el quickfit.

DE_Der Quickfit-Kopf sollte sich in der Mitte des Cam-Locks befinden, wenn die beiden Platten zusammengefügt sind.

Der Cam-Lock sollte vor dem Quickfit eingesetzt werden.

IT_La testa del montaggio rapido deve trovarsi al centro del bloccaggio a camma quando i due pannelli sono uniti.

Il Bloccaggio a Camma deve essere inserito prima del montaggio rapido.

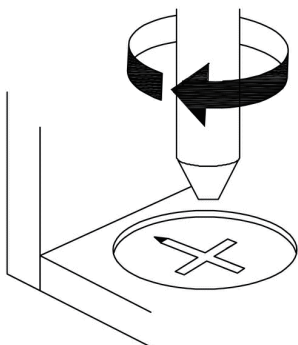

EN_Turn cam lock clockwise to tighten.

FR_Faites tourner la serrure batteuse dans le sens des aiguilles d'une montre pour la resserrer.

ES_Gire el cierre de la cámara en sentido horario para apretarlo.

DE_Drehen Sie den Cam-Lock im Uhrzeigersinn, um ihn festzuziehen.

IT_Ruotare il bloccaggio a camma in senso orario per stringere.

DE

1. Die maximale Tragfähigkeit der Oberplatte beträgt 60 kg, bitte nicht überladen.
2. Lassen Sie Kinder nicht auf Möbeln klettern, da dies zu Umstürzen und schweren Verletzungen führen kann.
3. Um die Sicherheit zu gewährleisten, installieren Sie bitte gemäß der Anleitung und ziehen Sie bei Bedarf Fachleute hinzu.
4. Stellen Sie Möbel nicht in die Nähe von Feuerquellen oder heißen Gegenständen, um Brandgefahr zu vermeiden.
5. Stellen Sie Möbel nicht in feuchten Umgebungen auf, um Materialschäden zu verhindern.
6. Überprüfen Sie regelmäßig alle Verbindungs- und Befestigungselemente, um sicherzustellen, dass sie fest sitzen und Unfälle zu vermeiden.

UK

1. The maximum weight capacity of the top panel is 60kg; please do not overload.
2. Do not allow children to climb on furniture, as this may cause tipping and serious injury.
3. To ensure safety, please install correctly according to the instructions and seek professional assistance if necessary.
4. Do not place furniture near fire sources or hot objects to avoid fire hazards.
5. Do not place furniture in damp environments to prevent material damage.
6. Regularly check all connectors and fasteners to ensure they are secure to prevent accidents.

FR

1. La charge maximale du panneau supérieur est de 60 kg, ne pas surcharger.
2. Ne laissez pas les enfants grimper sur les meubles, cela peut entraîner des basculements et des blessures graves.
3. Pour garantir la sécurité, installez correctement selon les instructions et demandez l'aide de professionnels si nécessaire.
4. Ne placez pas les meubles près de sources de chaleur ou d'objets chauds pour éviter les risques d'incendie.
5. Ne placez pas les meubles dans des environnements humides pour éviter d'endommager les matériaux.
6. Vérifiez régulièrement tous les connecteurs et les fixations pour vous assurer qu'ils sont bien serrés et éviter les accidents.

IT

1. La capacità massima del pannello superiore è di 60 kg; non sovraccaricare.
2. Non permettere ai bambini di arrampicarsi sui mobili, poiché ciò può causare ribaltamenti e gravi infortuni.
3. Per garantire la sicurezza, installare correttamente secondo le istruzioni e, se necessario, chiedere assistenza a professionisti.
4. Non posizionare i mobili vicino a fonti di calore o oggetti caldi per evitare rischi di incendio.
5. Non posizionare i mobili in ambienti umidi per prevenire danni ai materiali.
6. Controllare regolarmente tutti i connettori e le viti per assicurarsi che siano saldi e prevenire incidenti.

ES

1. La capacidad máxima del panel superior es de 60 kg; no sobrecargar.
2. No permita que los niños escalen los muebles, ya que esto puede causar volcaduras y lesiones graves.
3. Para garantizar la seguridad, instale correctamente según las instrucciones y busque ayuda profesional si es necesario.
4. No coloque los muebles cerca de fuentes de fuego u objetos calientes para evitar riesgos de incendio.
5. No coloque los muebles en ambientes húmedos para evitar daños en los materiales.
6. Revise regularmente todos los conectores y sujetadores para asegurarse de que estén seguros y prevenir accidentes.

NL

1. De maximale draagcapaciteit van het bovenpaneel is 60 kg; niet overbelasten.
2. Laat kinderen niet op meubels klimmen, dit kan leiden tot omvallen en ernstige verwondingen.
3. Installeer correct volgens de instructies om de veiligheid te waarborgen, en schakel indien nodig professionele hulp in.
4. Plaats meubels niet in de buurt van vuurbronnen of warme objecten om brandgevaar te voorkomen.
5. Plaats meubels niet in vochtige omgevingen om materiaalschade te voorkomen.
6. Controleer regelmatig alle verbindingen en bevestigingsmiddelen om ervoor te zorgen dat ze stevig zijn en om ongevallen te voorkomen.

SE

1. Den maximala viktkapaciteten för överpanelen är 60 kg; överbelasta inte.
2. Låt inte barn klättra på möbler, då detta kan orsaka tippning och allvarliga skador.
3. För att säkerställa säkerheten, installera korrekt enligt instruktionerna och sök professionell hjälp om det behövs.
4. Placera inte möbler nära eldkällor eller heta föremål för att undvika brandrisk.
5. Placera inte möbler i fuktiga miljöer för att förhindra skador på materialen.
6. Kontrollera regelbundet alla kopplingar och fästelement för att säkerställa att de är säkra för att förhindra olyckor.

PL

1. Maksymalne obciążenie górnej płyty wynosi 60 kg; nie przeciążaj.
2. Nie pozwól dzieciom wspinąć się na meble, ponieważ może to prowadzić do przewrócenia się i poważnych obrażeń.
3. Aby zapewnić bezpieczeństwo, zainstaluj prawidłowo zgodnie z instrukcją i w razie potrzeby skorzystaj z pomocy profesjonalistów.
4. Nie stawiaj mebli w pobliżu źródeł ognia lub gorących przedmiotów, aby uniknąć ryzyka pożaru.
5. Nie stawiaj mebli w wilgotnych środowiskach, aby zapobiec uszkodzeniu materiałów.
6. Regularnie sprawdzaj wszystkie złącza i elementy mocujące, aby upewnić się, że są stabilne i aby zapobiec wypadkom.

-Components - fittings

Please check you have all the panels listed below.

Note: The quantitie below are the correct amount to complete the assembly. In some cases more fittings may be supplied than are required.

-Komponenten Verschraubungen

Bitte überprüfen Sie, ob Sie alle unten aufgeführten Panels haben.

Hinweis: Die folgende Menge ist die richtige Menge, um die Montage abzuschließen. In einigen Fällen können mehr Armaturen geliefert werden, als erforderlich.

-Composants - accessoires

Veuillez vérifier que vous possédez tous les panneaux énumérés ci - dessous.

Remarque: les quantités ci - dessous sont les quantités correspondantes nécessaires pour terminer

l'assemblage. Dans certains cas, plus d'accessoires que nécessaire peuvent être fournis.

N620P355731- Box:1/2

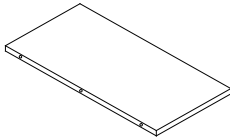
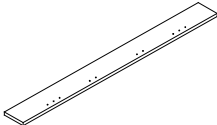
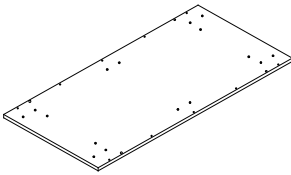
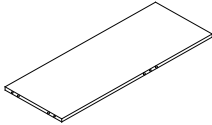
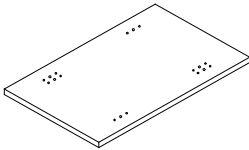
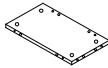
 ② X1	 ④ X2	 ⑤ X1
 ⑥ X1	 ⑦ X1	 ⑧ X2

N620P355732- Box:2/2

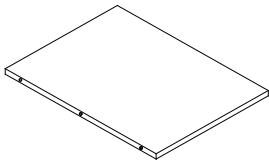
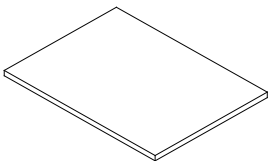
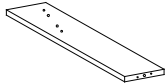
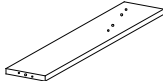
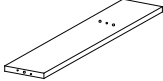
 ① X1	 ③ X1	 ⑨ X2
 ⑩ X2	 ⑪ X2	

•Components - fittings

Please check you have all the panels listed below.

Note: The quantitie below are the correceet amount to complete the assembly. In some cases more fittings may be supplied than are required.

•Komponenten Verschraubungen

Bitte überprüfen Sie, ob Sie alle unten aufgeführten Panels haben.

Hinweis: Die folgende Menge ist die richtige Menge, um die Montage abzuschließen. In einigen Fällen

können mehr Armaturen geliefert werden, als erforderlich.







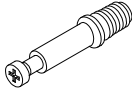

•Composants - accessoires

Veuillez vérifier que vous possédez tous les panneaux énumérés ci - dessous.

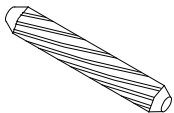
Remarque: les quantités ci - dessous sont les quantités correspondantes nécessaires pour terminer

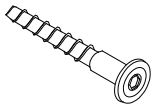
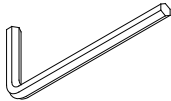
l'assemblage. Dans certains cas, plus d'accessoires que nécessaire peuvent être fournis.

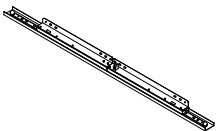
N620P355731- Box:1

				
6*35mm	15*10mm	6*30mm		6*40mm
Ax14PCS	Bx14PCS	Cx36PCS	Dx6PCS	Ex38PCS
				
Fx1PC	Gx4PCS	Hx2PCS	5*14mm	
			Ix44PCS	

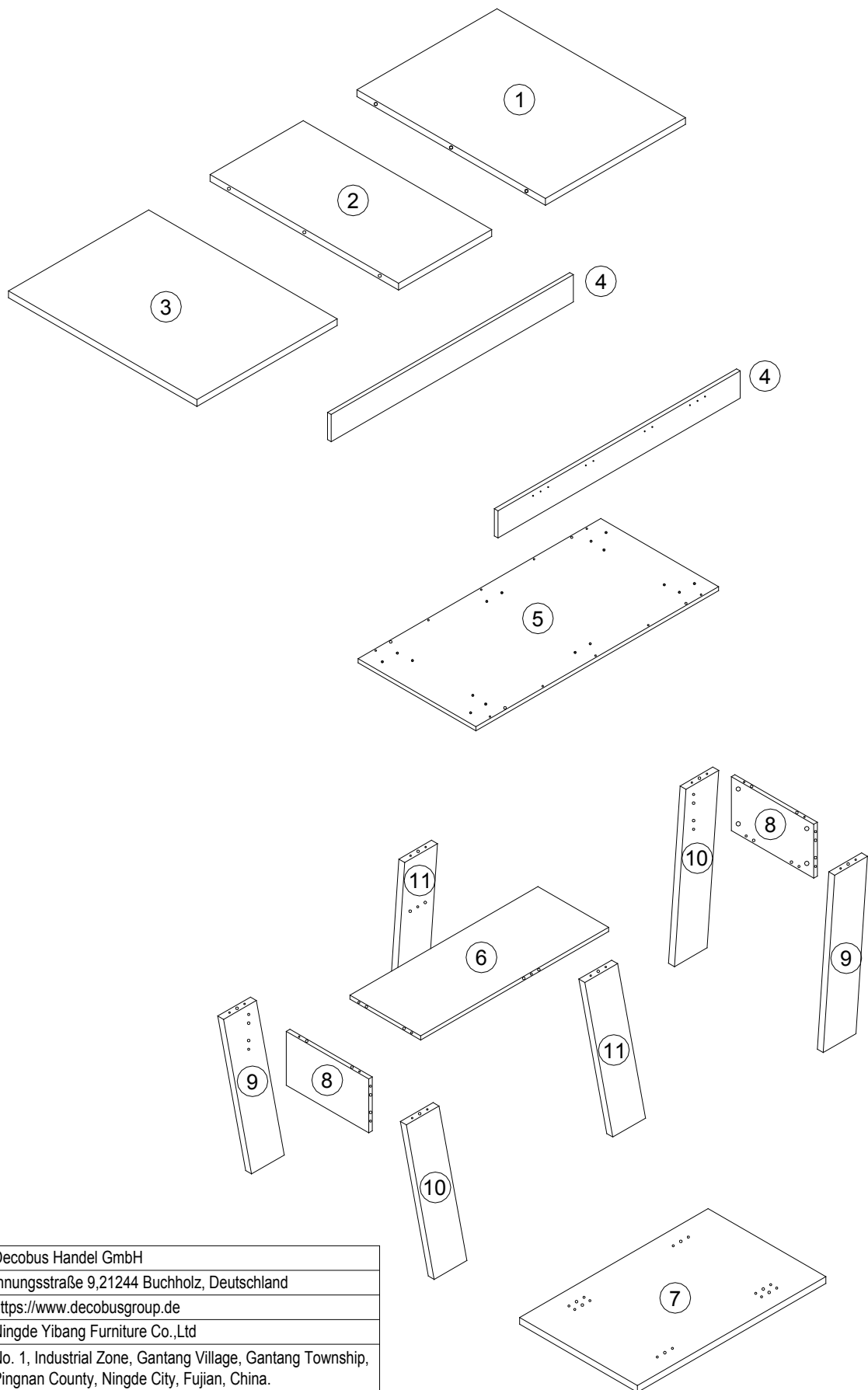

Importeur	Decobus Handel GmbH		
Adresse	Innungsstraße 9, 21244 Buchholz, Deutschland		
URL	https://www.decobusgroup.de		
Hersteller	Ningde Yibang Furniture Co., Ltd		
Adresse	No. 1, Industrial Zone, Gantang Village, Gantang Township, Pingnan County, Ningde City, Fujian, China.		
Email/URL	yvonne@yibang-fur.com		
Partienummer	C253DYB20250716FC		
Hergestellt in	CHINA		
<table border="1" style="display: inline-table; vertical-align: middle;"> <tr> <td>EC</td> <td>REP</td> </tr> </table>	EC	REP	Decobus Handel GmbH Innungsstraße 9, 21244 Buchholz, Deutschland https://www.decobusgroup.de
EC	REP		

STEP 1/SCHRITT 1/étapes 1/Passo 1/Paso 1

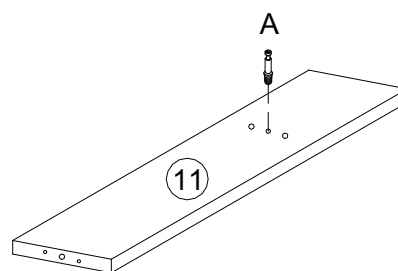
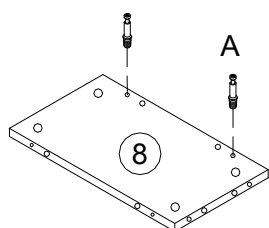
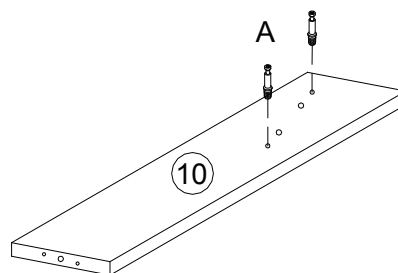
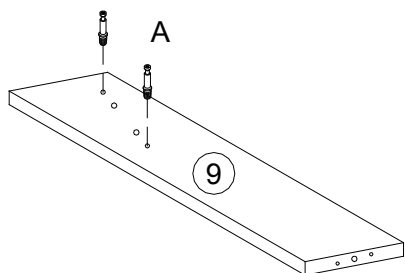



x2

A x 14pcs

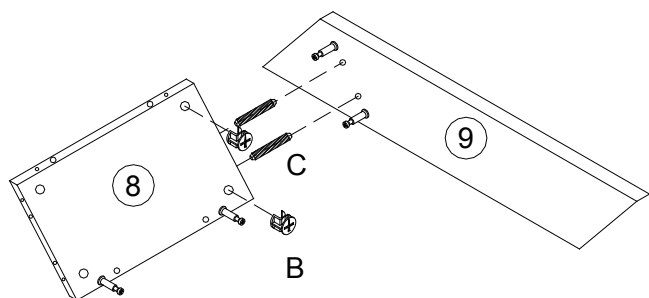
STEP 2/SCHRITT 2/
étapes 2/Passo 2/Paso 2





x2

	
B x 4pcs	C x 4pcs

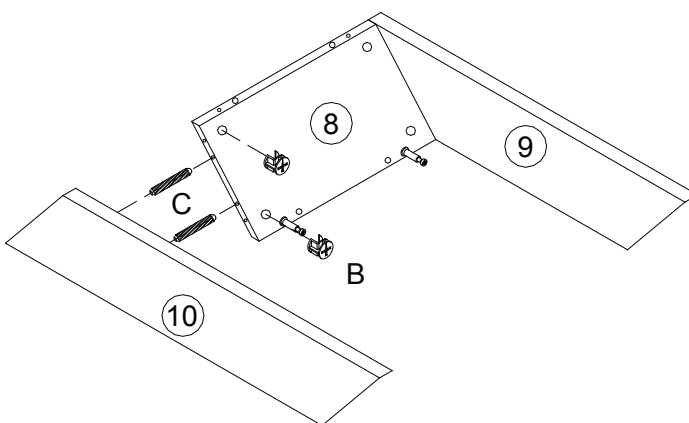
STEP 3/SCHRITT 3/
étapes 3/Passo 3/Paso 3





x2

	
B x 4pcs	C x 4pcs

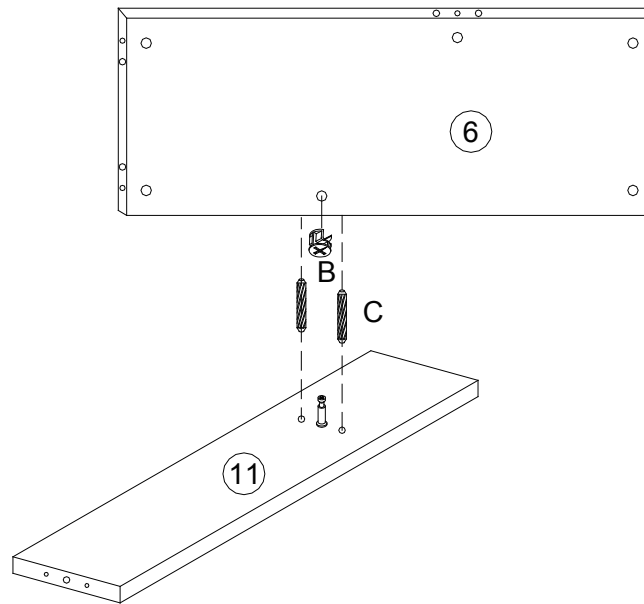

STEP 4/SCHRITT 4/étapes 4/Passo 4/Paso 4



	
B x 1pc	C x 2pcs

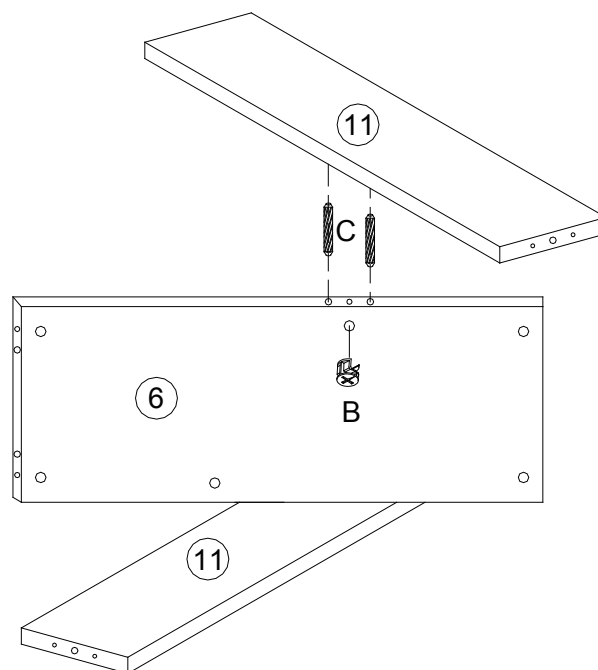

STEP 5/SCHRITT 5/étapes 5/Passo 5/Paso 5



	
B x 1pc	C x 2pcs

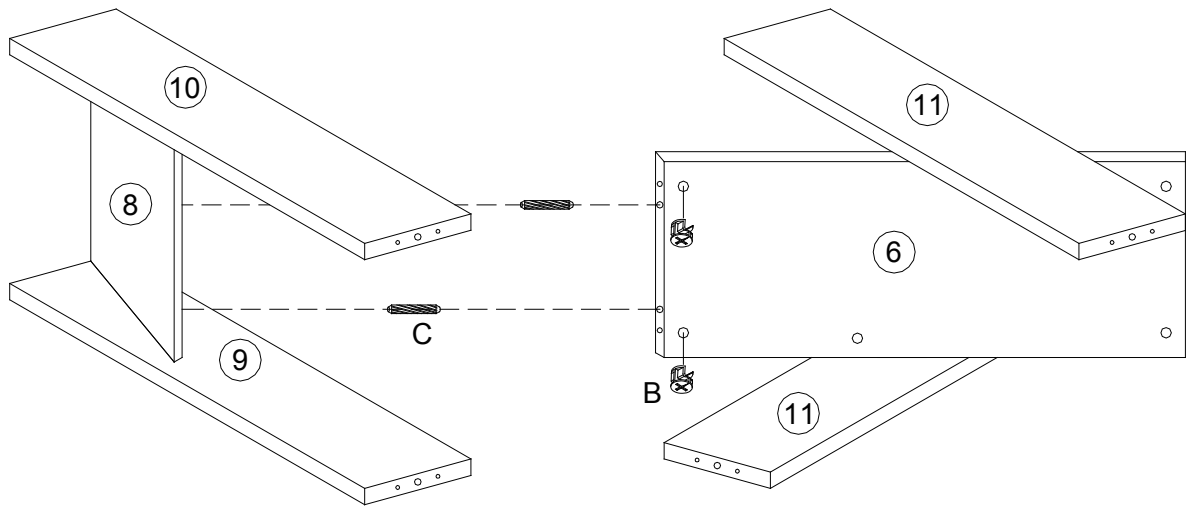

STEP 6/SCHRITT 6/étapes 6/Passo 6/Paso 6

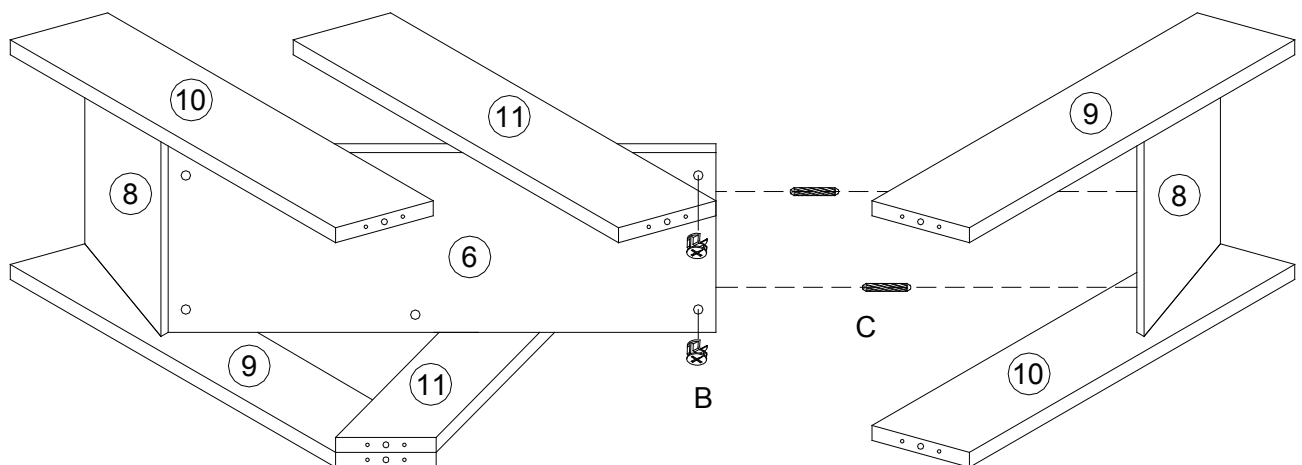

	
B x 2pcs	C x 2pcs

STEP 7/SCHRITT 7/étapes 7/Passo 7/Paso 7





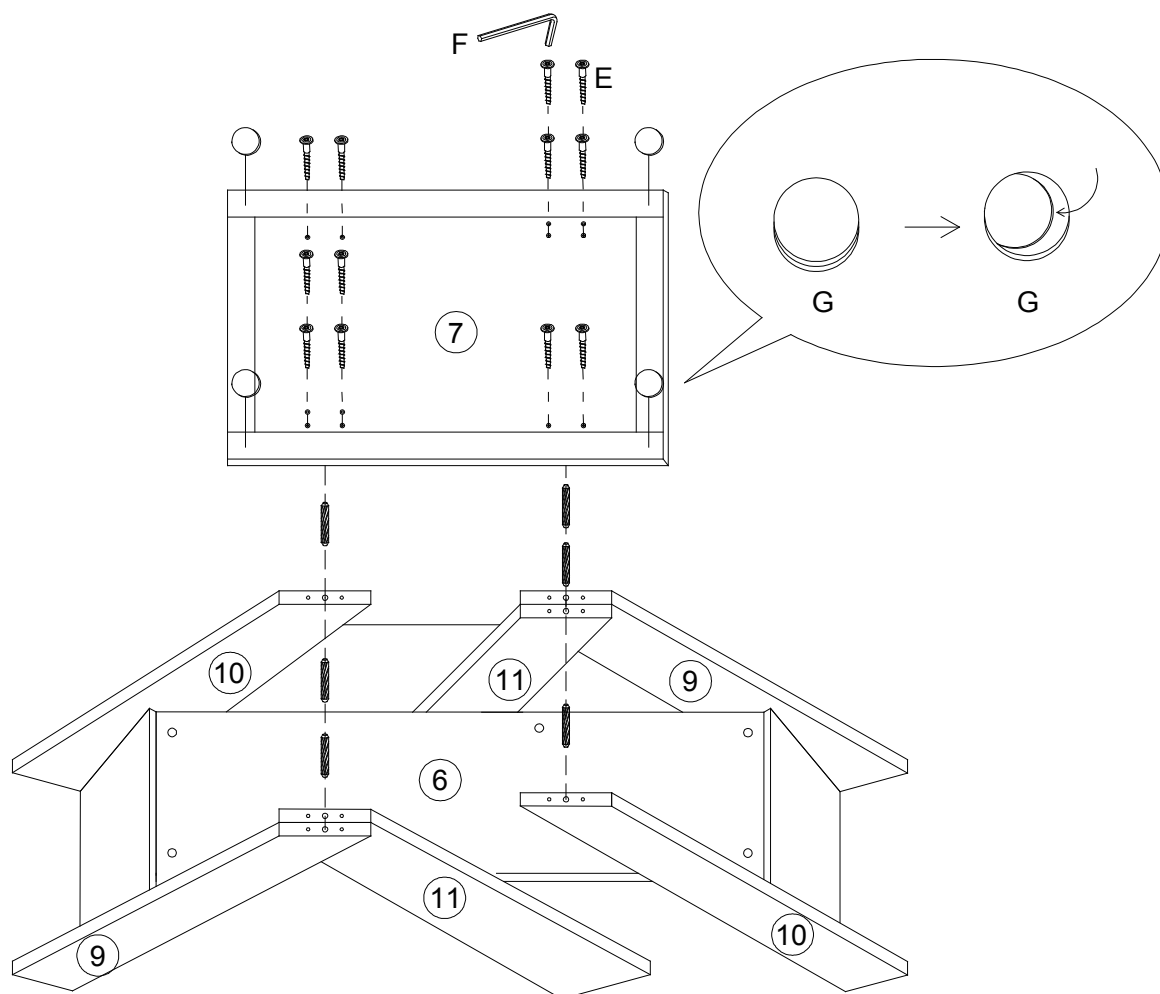

	
B x 2pcs	C x 2pcs

STEP 8/SCHRITT 8/étapes 8/Passo 8/Paso 8

NOTE:97% TIGHTEN BEFORE FIXING ALL BOLTS



			
C x 6pcs	E x 12pcs	F x 1pc	G x 4pcs

STEP 9/SCHRITT 9/étapes 9/Passo 9/Paso 9

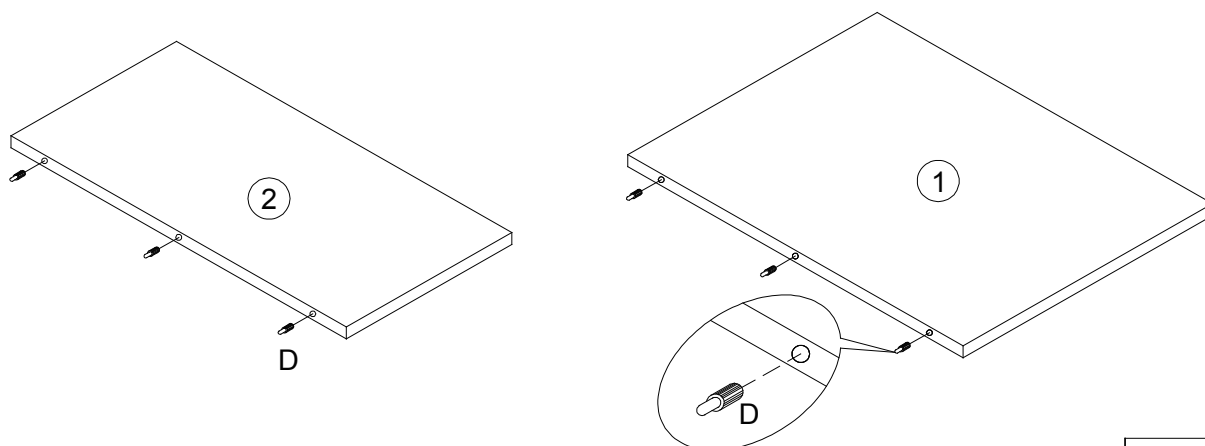



D x 6pcs

Installationsanleitung/Installation Instruction/Instruction d'installation
Istruzioni di installazione/Instrucciones de instalación

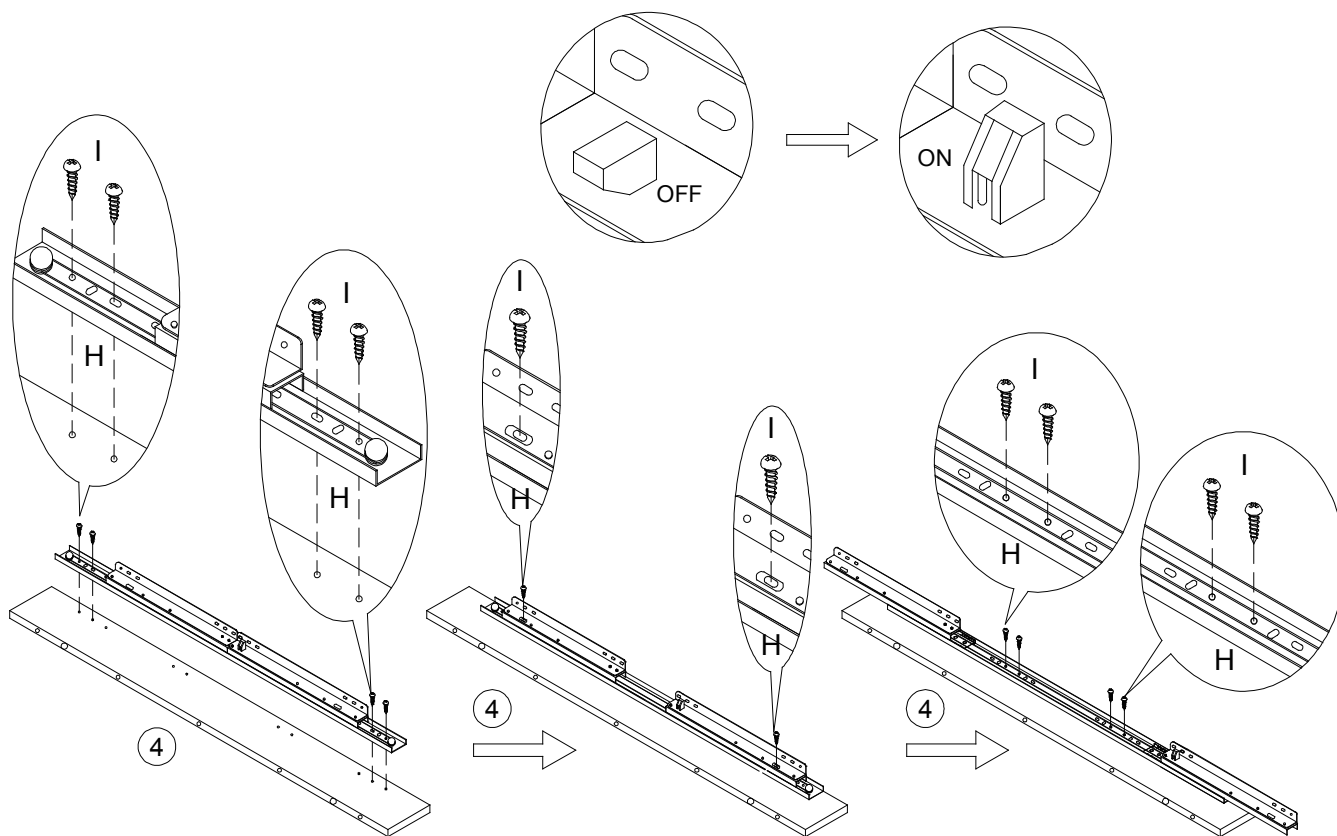
STEP 10/SCHRITT 10/étapes 10/Passo 10/Paso 10





x2

	
H x 2pcs	I x 20pcs

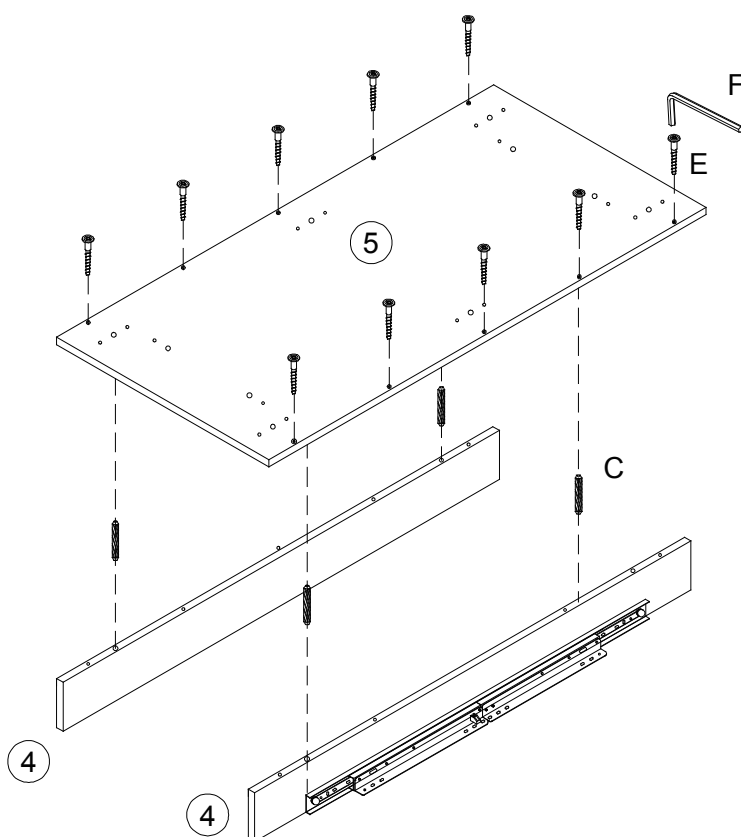
STEP 11/SCHRITT 11/étapes 11/Passo 11/Paso 11



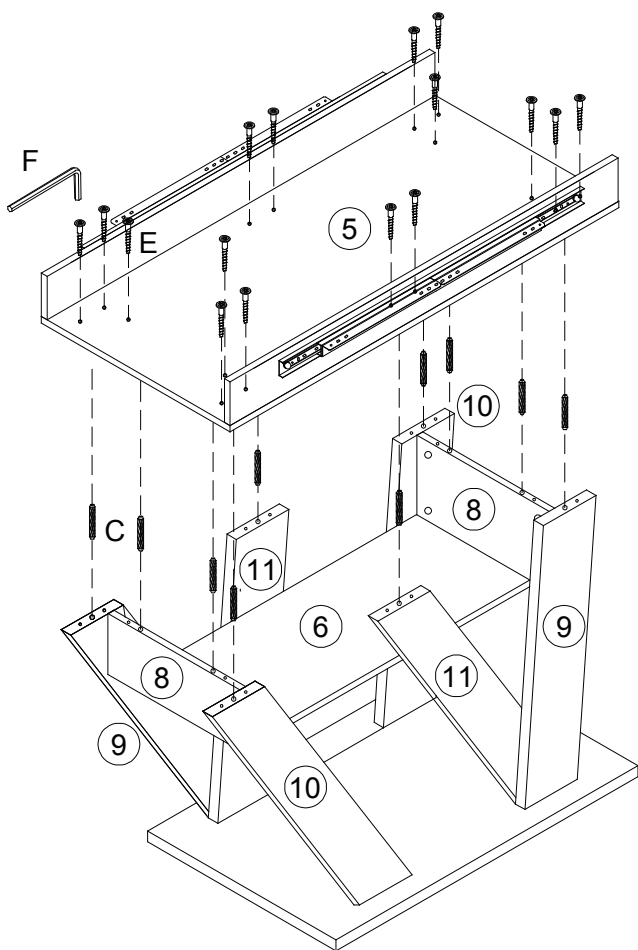

	
C x 4pcs	E x 10pcs

STEP 12/SCHRITT 12/étapes 12/Passo 12/Paso 12



NOTE: 100% TIGHTEN ALL THE BOLTS OF STEP 12, THEN 100% TIGHTEN ALL THE BOLTS OF STEP 8

	
C x 10pcs	E x 16pcs

STEP 13/SCHRITT 13/étapes 13/Passo 13/Paso 13

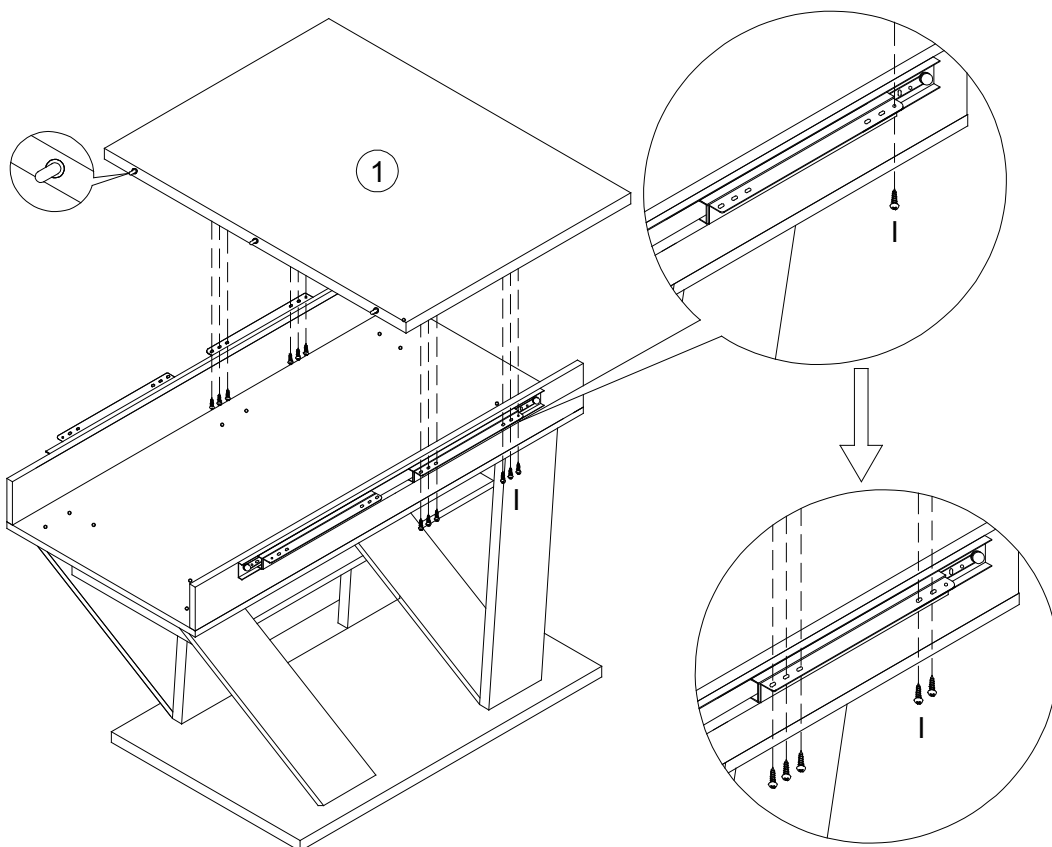

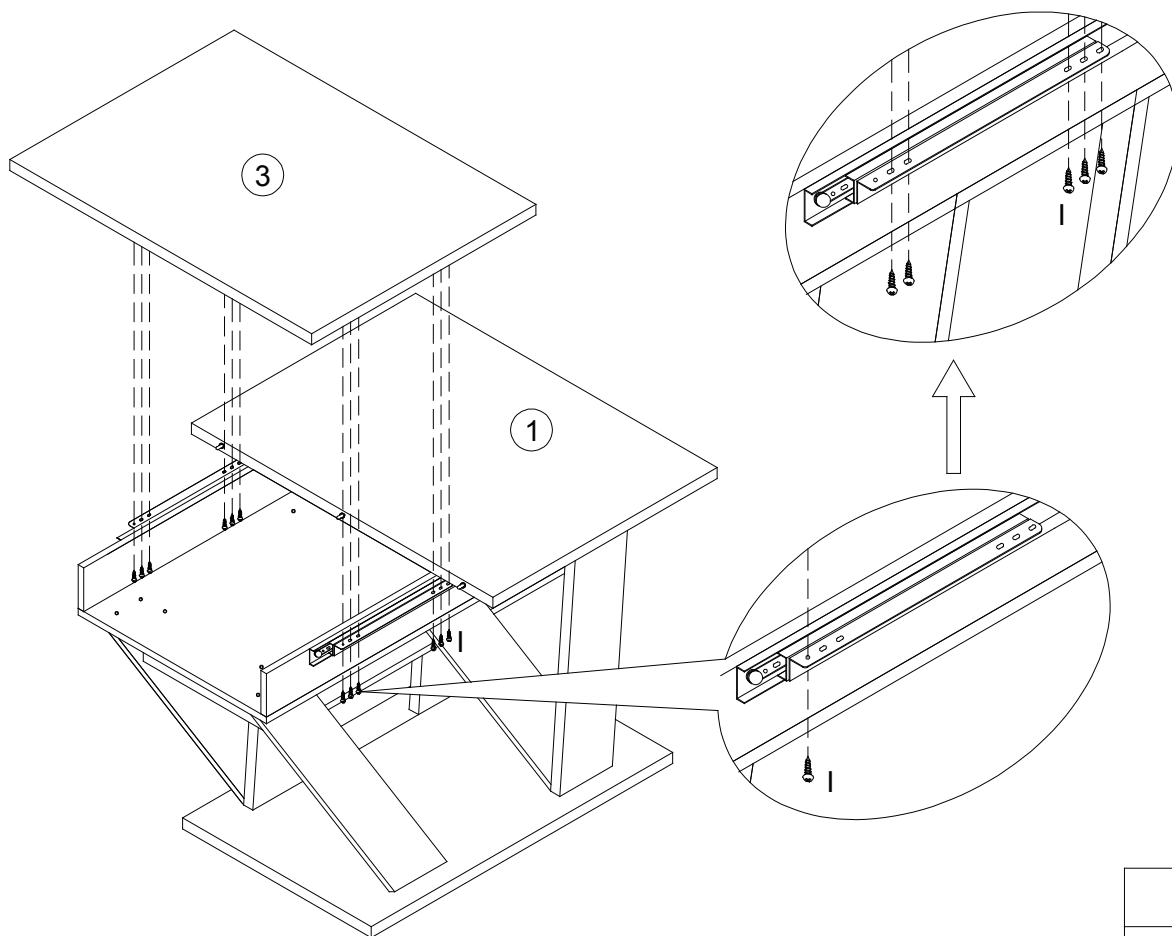

I x 12pcs

STEP 14/SCHRITT 14/étapes 14/Passo 14/Paso 14



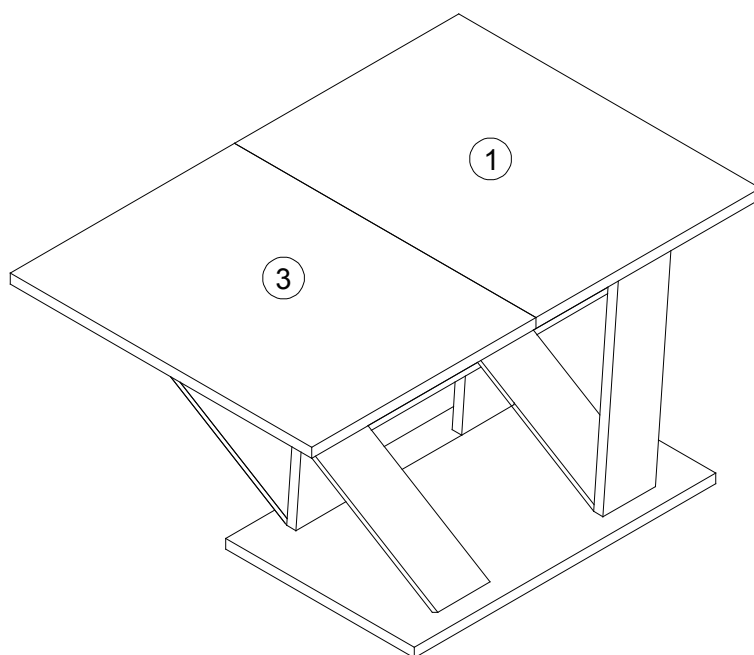

I x 12pcs

STEP 15/SCHRITT 15/étapes 15/Passo 15/Paso 15

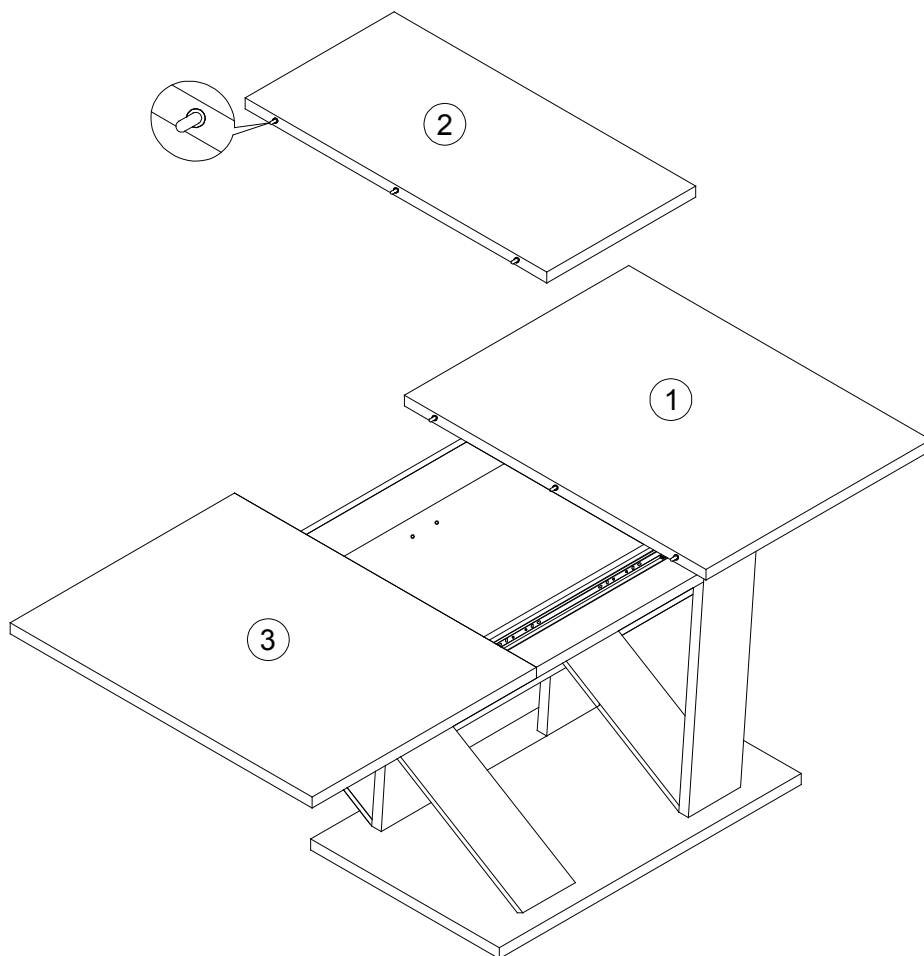

STEP 16/SCHRITT 16/étapes 16/Passo 16/Paso 16



STEP 17/SCHRITT 17/étapes 17/Passo 17/Paso 17

