

## NOTICE

---

- \* Please make sure that you have all parts indicated and they are in good condition before you begin assembly of this item. Refer to part list and hardware list below for guidance.
- \* This item should be assembled on a soft surface to prevent scratching the finish during assembly.
- \* This item may require periodic tightening.
- \* If you are having difficulty, our friendly Customer Care team is always here to help. Please email [customersupport@safavieh.com](mailto:customersupport@safavieh.com)

## PREPARATION

---

- \* Before beginning assembly of product, make sure all parts are present. Compare parts with part contents list and hardware contents list.
- \* If any part is missing or damaged, do not attempt to assemble the product.
- \* Estimated Assembly Time : 10 minutes.
- \* Tools required for Assembly (included) : Allen Key
- \* Tools Required for Assembly (not included) : Screwdriver

## CARE AND MAINTENANCE

---

**WOOD CARE:** Adhesive felt pads should always be applied to areas of furniture which make direct contact with flooring, said application will prevent damage to the furniture and or surfaces on which the furniture lies. Objects placed on articles of furniture should rest on nonabrasive material as to prevent damage to the wood finish. Wipe up spills immediately and avoid common hazards such as hot dishes, harsh solvents and abrasives. Cleaning should be done with a soft lint free cotton cloth dampened with water or furniture polish.

**UPHOLSTERY CARE:** To prevent overall soiling, frequent vacuuming or light brushing is recommended. Cushions and pillows should be turned on a weekly basis. Down-filled cushions should be brushed rather than vacuumed. Spot clean should undertake a complete overall cleaning. The use of steam or water-based cleaners may cause excessive shrinking or staining.



**ITEM ID:** DTB1410

**ITEM DIMENSION:** 47.24"W x 31.49 (16.53)"D x 29.52"H

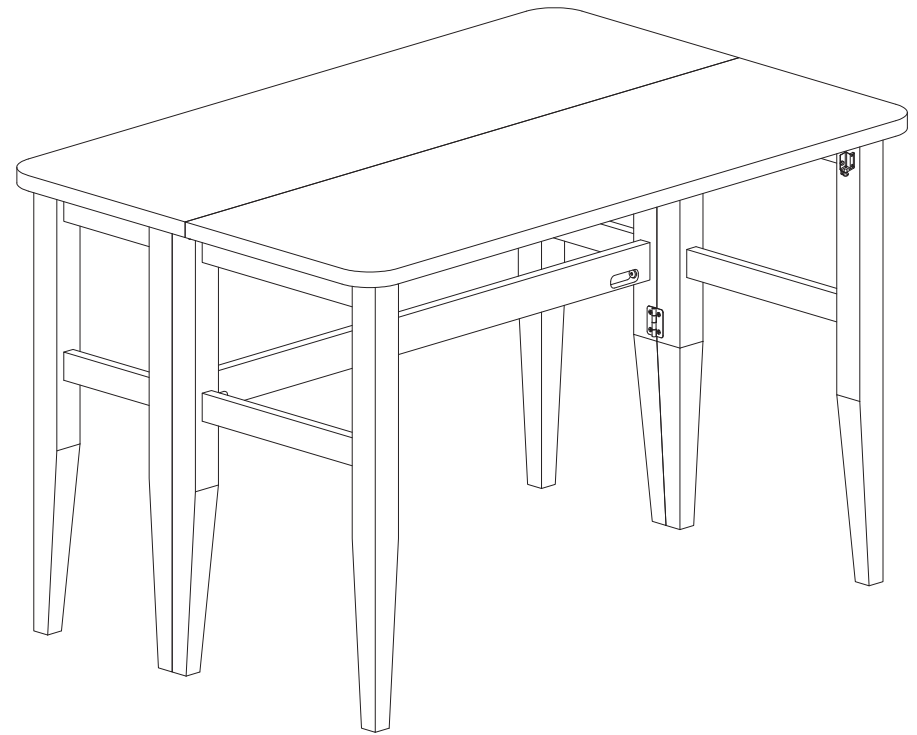







**WARNING**

Weight capacity - 206 LBS

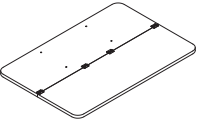
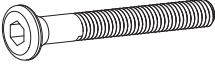
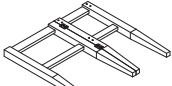
Warning : Do not stand on table.

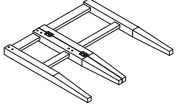
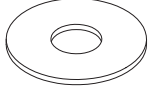
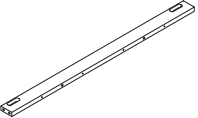
Warning : Do not over torque bolts.

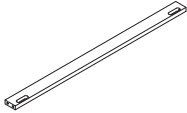
## Part List and Hardware List

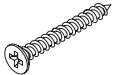
PIECE	DESCRIPTION	PICTURE	QTY	PIECE	DESCRIPTION	PICTURE	QTY
A	TABLE TOP		1x	HW 1	Jcbb Bolt M6x0.5x50mm		6x
B	LEG FRAME (LEFT)		1x	HW 2	Spring Washer 6mm		6x
C	LEG FRAME (RIGHT)		1x	HW 3	Flat Washer 6mm		6x
D	TOP STRETCHER		2x	HW 4	Allen Key M4 (Long)		1x
E	BOTTOM STRETCHER		1x	HW 5	Wood Dowel 8x30		10x
				HW 6	CSK Screw M4x2.0x30mm		8x

# PREPARATION

- \* Before beginning assembly of product, make sure all parts are present. Compare parts with part contents list and hardware contents list.
- \* If any part is missing or damaged, do not attempt to assemble the product.
- \* Estimated Assembly Time : 10 minutes.
- \* Tools Required for Assembly (included) : Allen Key
- \* Tools Required for Assembly (not included) : Screwdriver

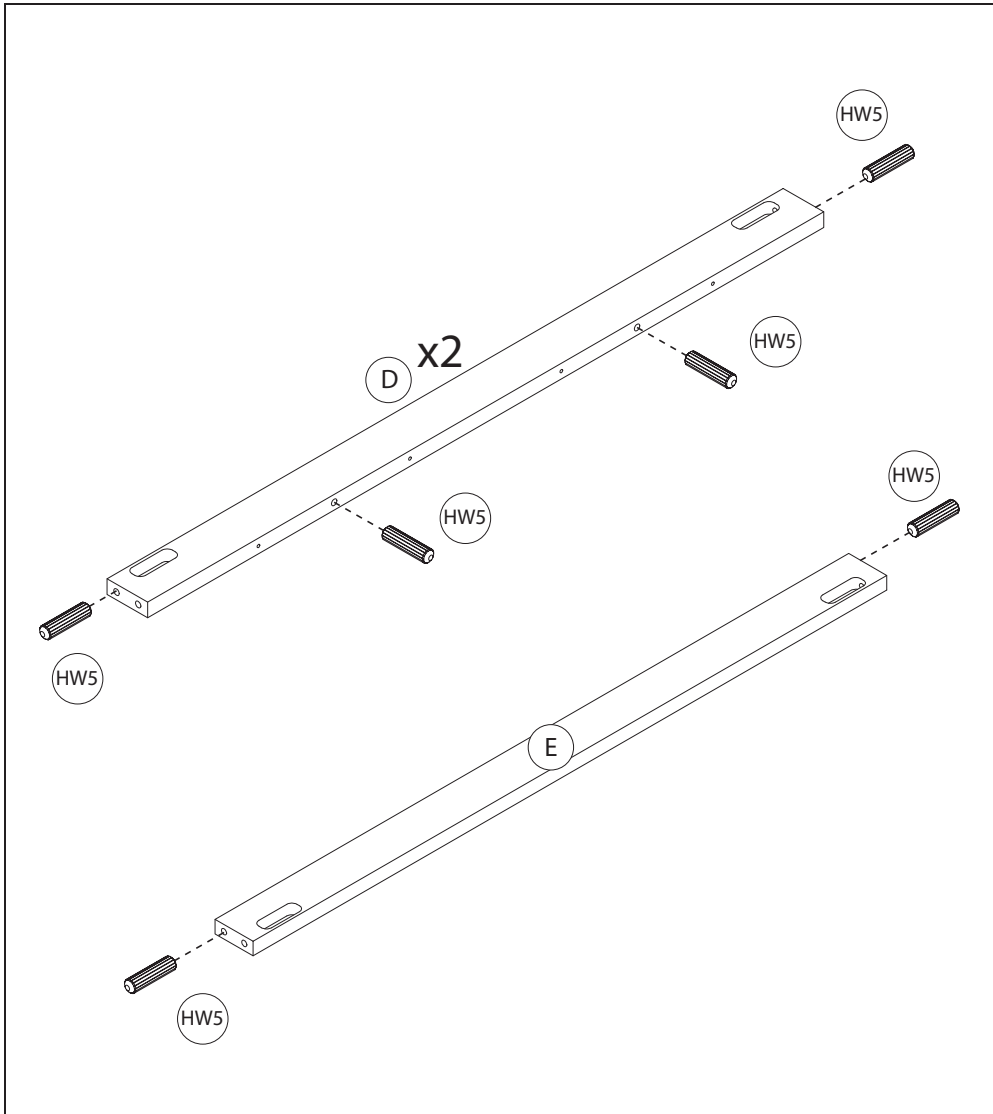

**Step 1 :** Attach Wood Dowel (HW5) to the Top Stretcher (D) and Bottom Stretcher (E).

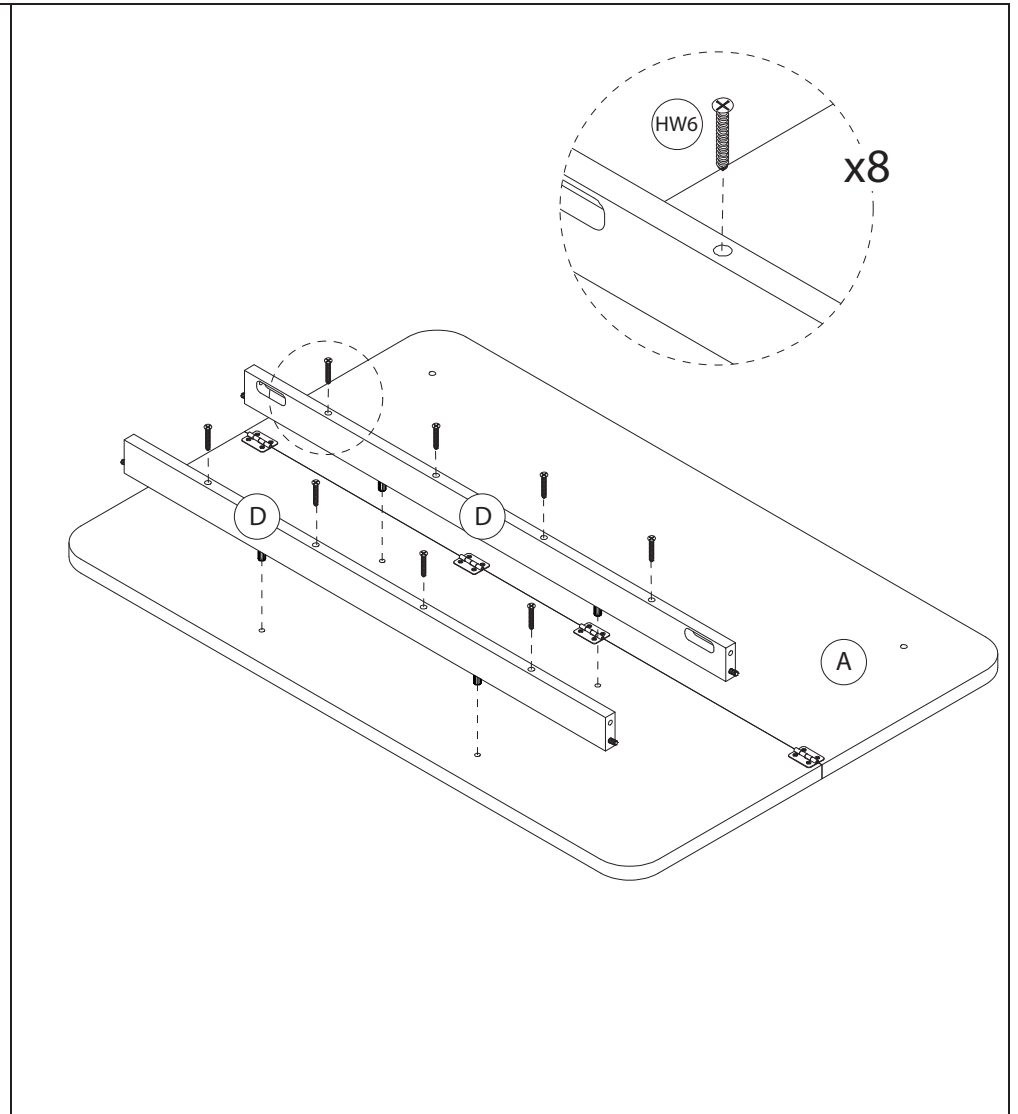

**Step 2 :** Attach the Top Stretcher (D) to the Table Top (A). Align the wood dowel at the top stretcher with the hole at the table top. Screw in the top stretcher using Screws (HW6).

# PREPARATION

- \* Before beginning assembly of product, make sure all parts are present. Compare parts with part contents list and hardware contents list.
- \* If any part is missing or damaged, do not attempt to assemble the product.
- \* Estimated Assembly Time : 10 minutes.
- \* Tools Required for Assembly (included) : Allen Key
- \* Tools Required for Assembly (not included) : Screwdriver

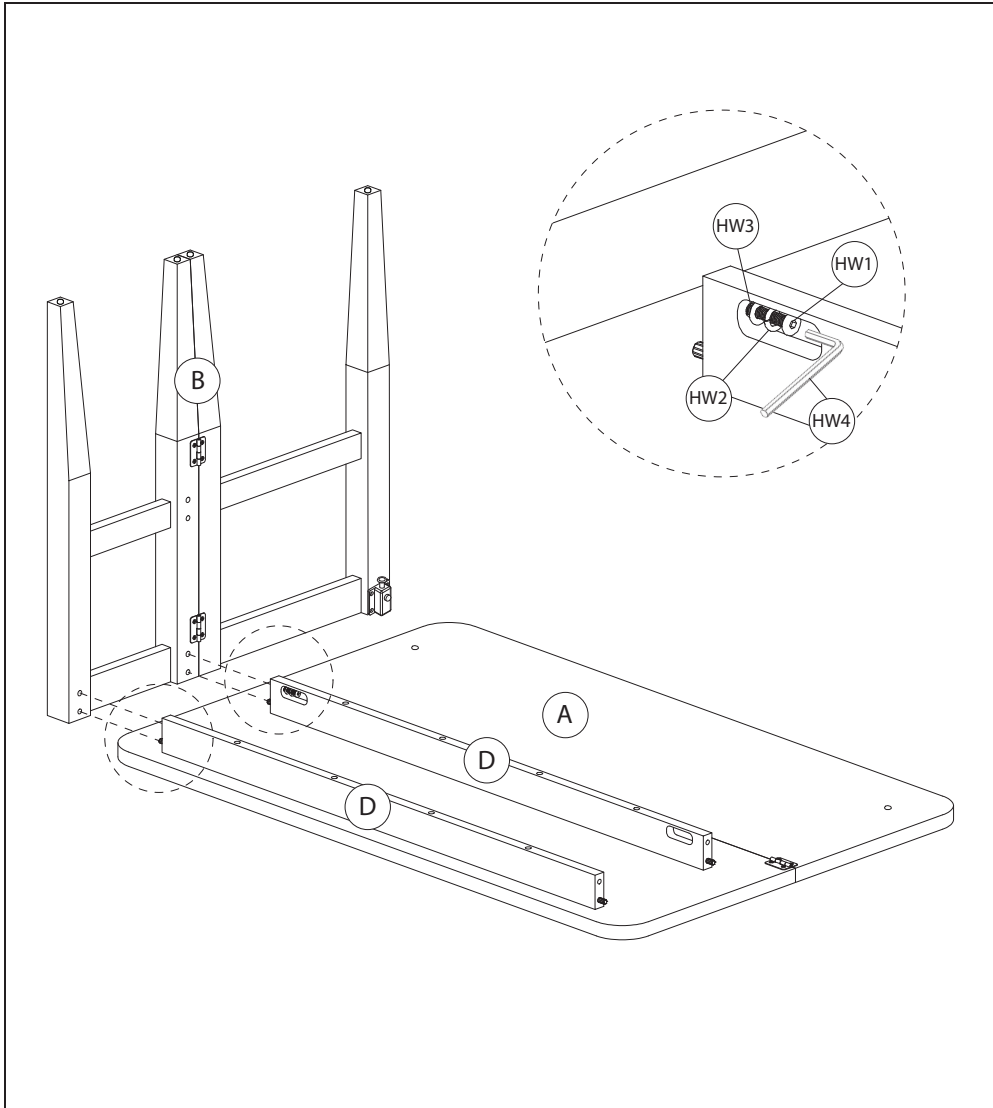

**Step 3 :** Place table leg (left)(B) to the position align with the wood dowel at the stretchers (D). Screw in the bolts (HW1). Put the washer (HW2,HW3) on the bolts (HW1) in the order shown.

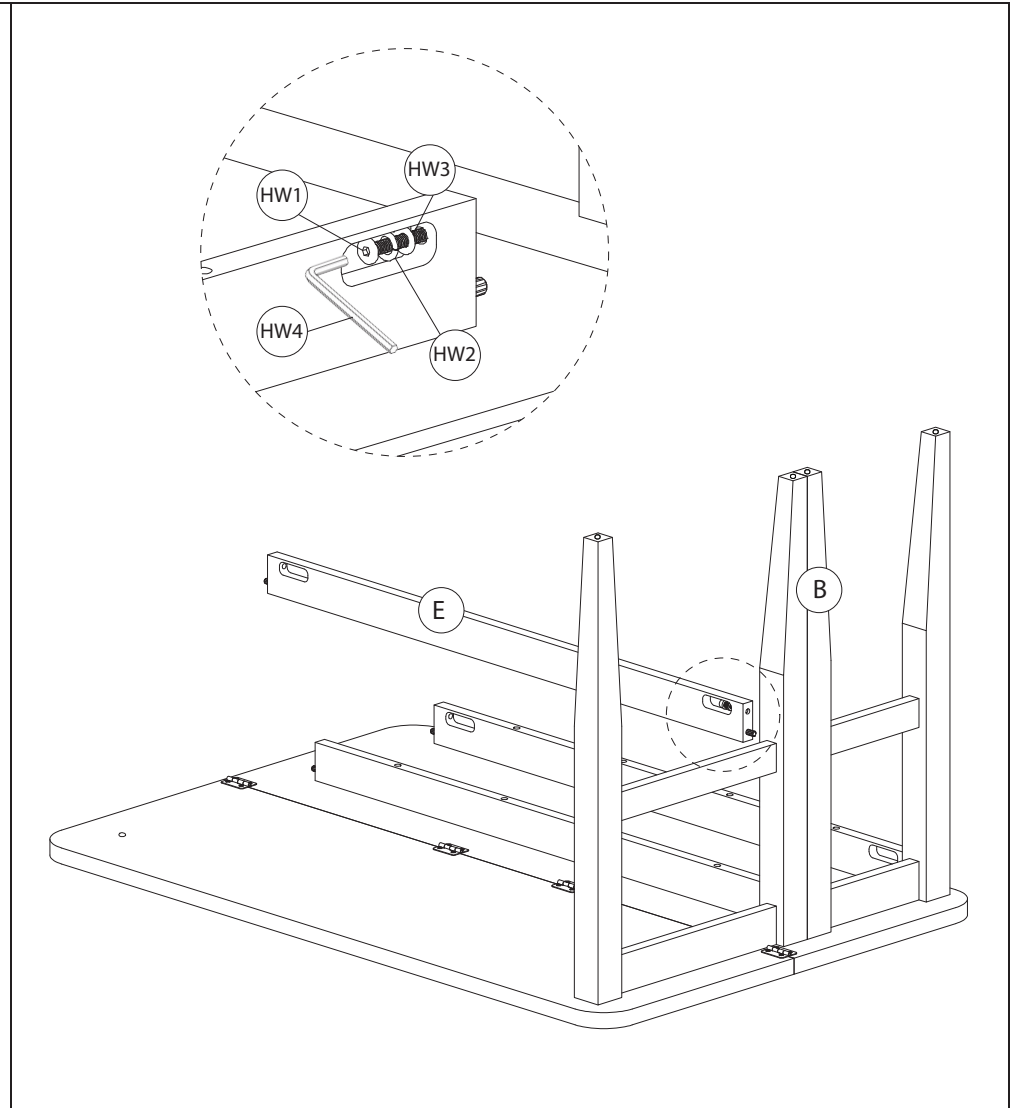

**Step 4 :** Attach the stretcher (E) to the leg (B). Screw in the bolts (HW1). Put the washer (HW2,HW3) on the bolts (HW1) in the order shown.

# PREPARATION

- \* Before beginning assembly of product, make sure all parts are present. Compare parts with part contents list and hardware contents list.
- \* If any part is missing or damaged, do not attempt to assemble the product.
- \* Estimated Assembly Time : 10 minutes.
- \* Tools Required for Assembly (included) : Allen Key
- \* Tools Required for Assembly (not included) : Screwdriver

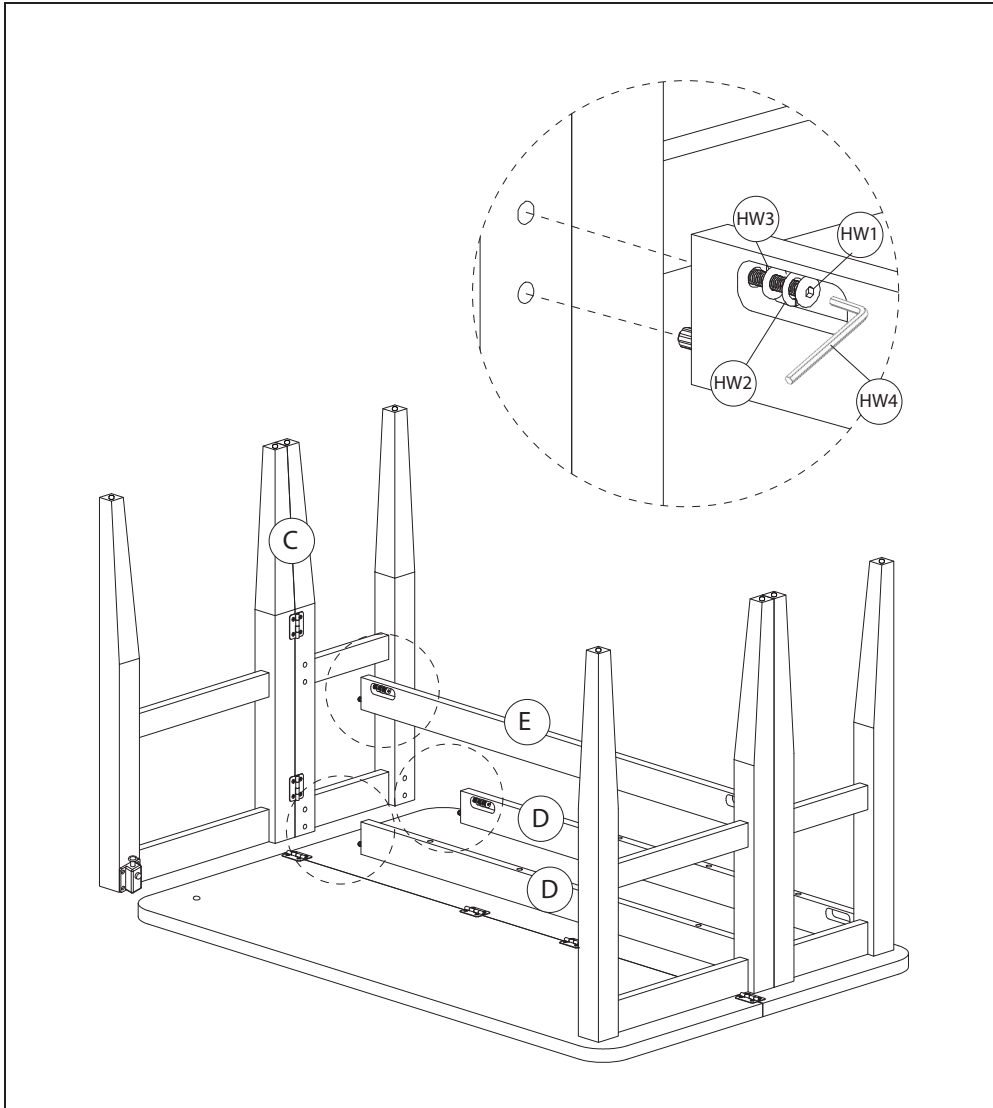

**Step 5 :** Attach leg (right) (C) align to the stretchers (D & E). Screw in the bolts (HW1).Put in the washers (HW2,HW3) on the bolts (HW1) in the order shown.

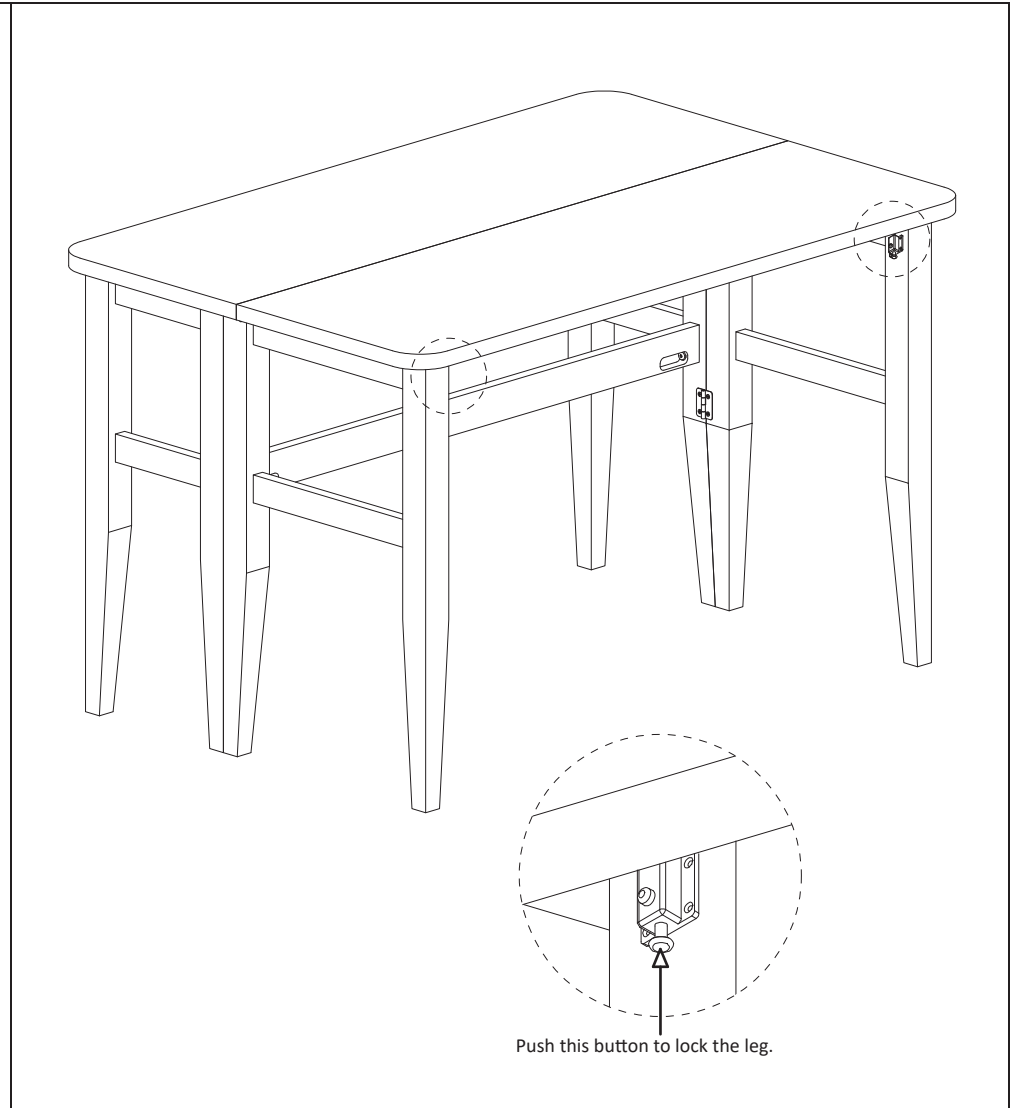

**Step 6 :** Lock the leg to the table top by push the lock button at both leg.

# HOW TO USE (CLOSE)

## Step 1

Unlock the lock at the leg. Push the leg to the inside.

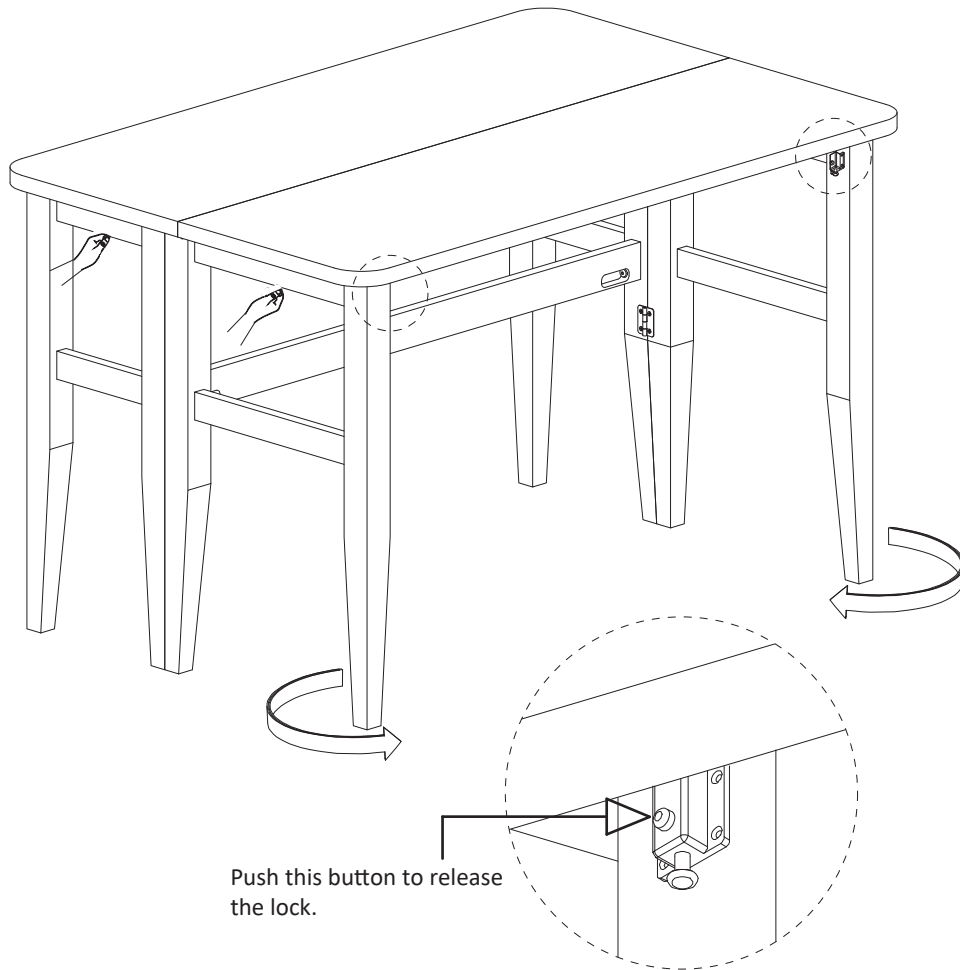

## Step 2

Slowly let down the table top.

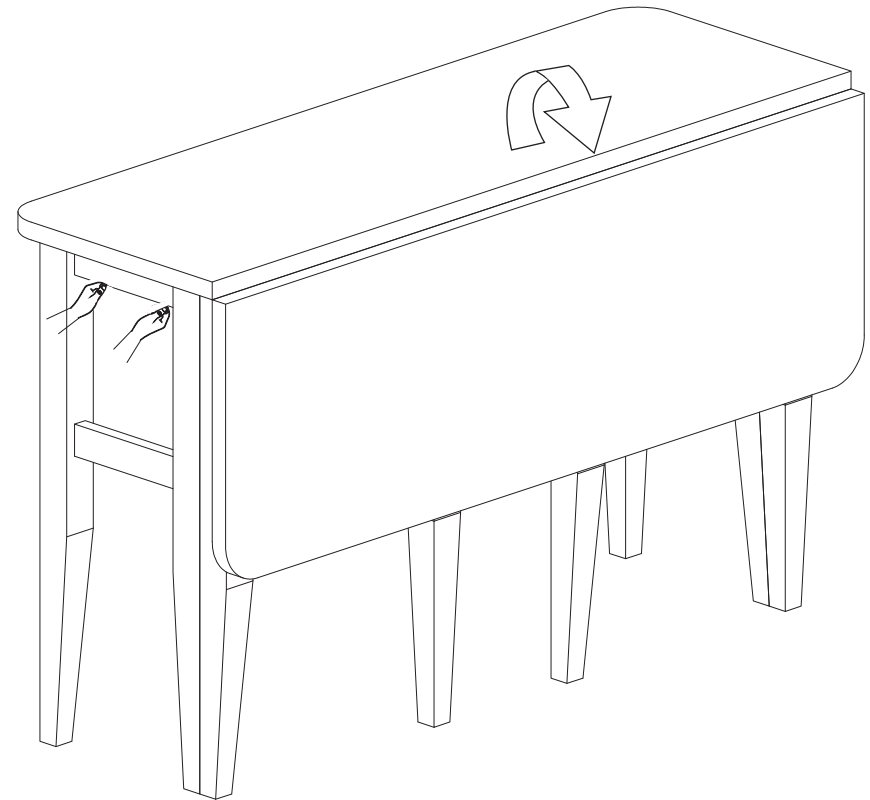

**Important Reminder : ( 2 people needed to lift)  
Please lift the table by the side of table.**

# HOW TO USE (OPEN)

## Step 1

Pull up the table top.

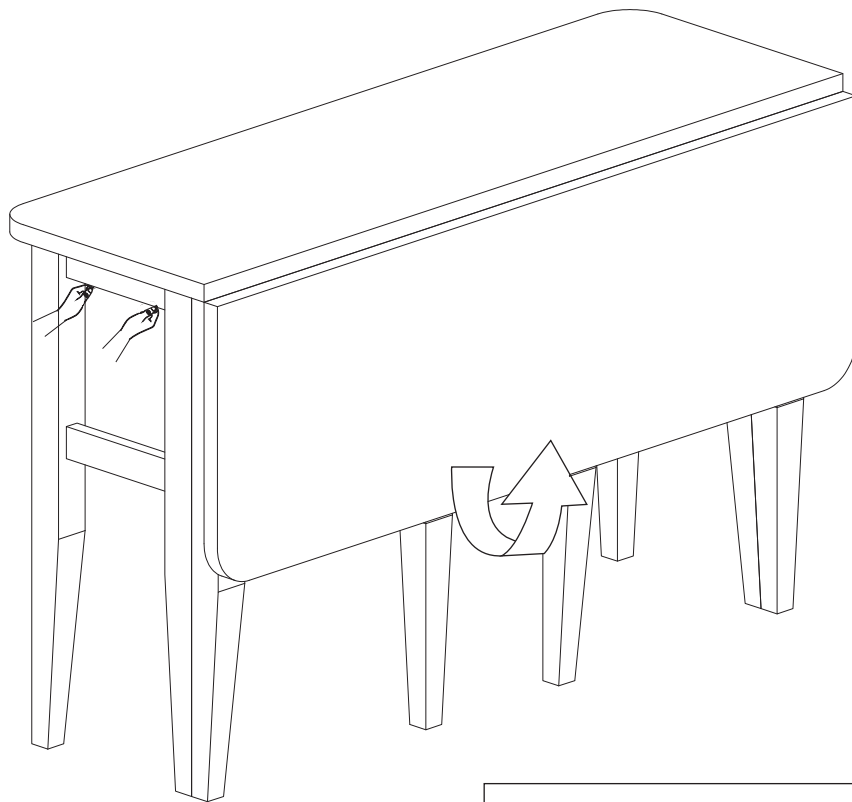

## Step 2

Pull out both of the table legs. Lock the leg to the table top.

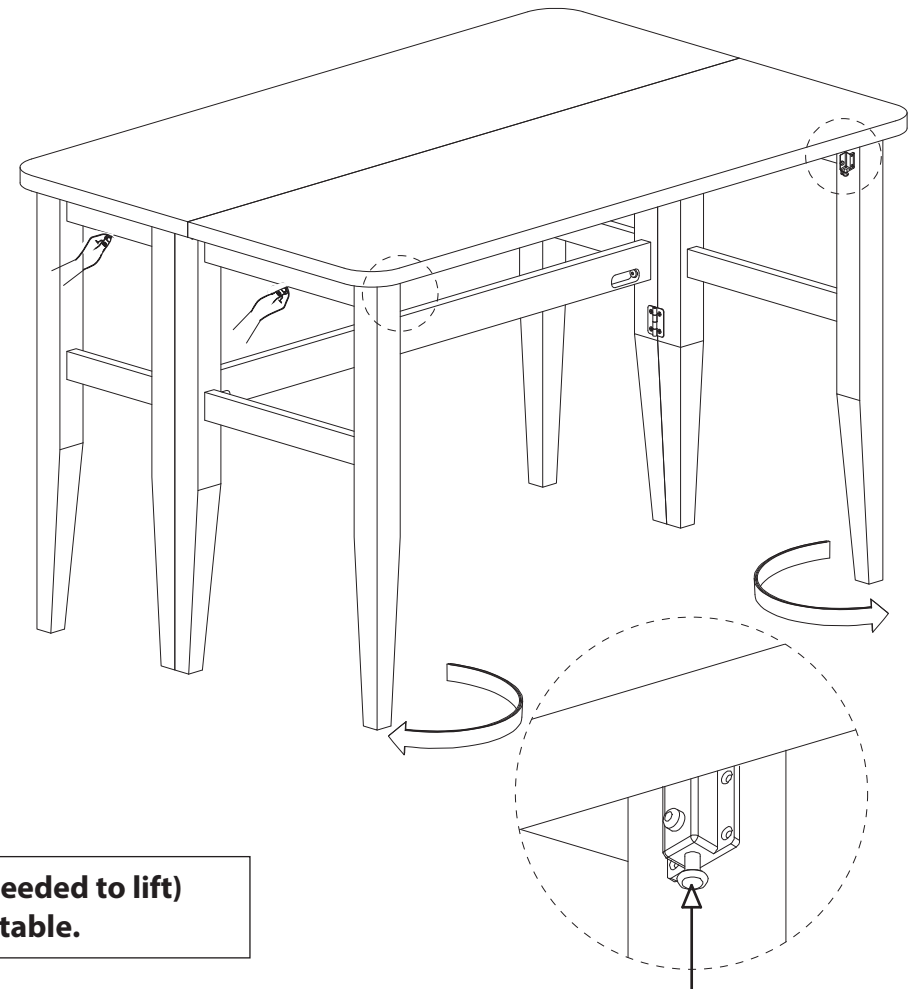

**Important Reminder : ( 2 people needed to lift)  
Please lift the table by the side of table.**

Push this button to lock the leg after the table open.