

MODEL/MODELO
G78422-01

Assembly Instructions

Instrucciones De Ensamblaje

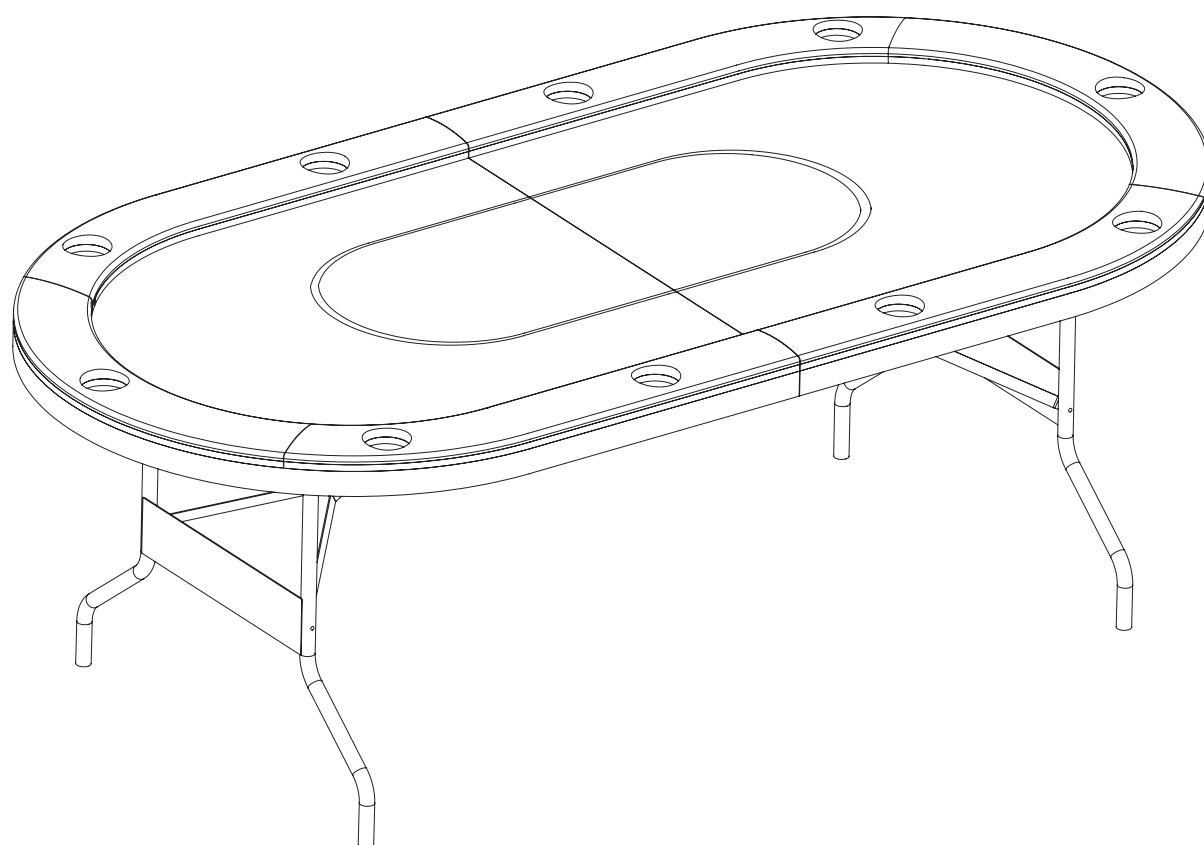

PARTS IDENTIFIER

IDENTIFICADOR DE PIEZAS

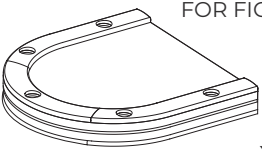
PART NUMBER NÚMERO DE PIEZA	1	FOR FIG. 1	FIG NUMBER NÚMERO DE FIG
PART PIEZA			QUANTITY CANTIDAD
PART NAME	Folded Poker Table	Plegable mesa para póker	NOMBRE DE PIEZA









HARDWARE

HARDWARE

A1		x1
Wrench	Llave Inglesa	

PRE-INSTALLED PARTS

PIEZAS PREINSTALADAS

P1	FOR FIG. 2	P2	FOR FIG. 2	P3	FOR FIG. 1	P4	FOR FIG. 2
	x4		x16		x10		x4
"U" Bracket	Corchete "U"	4x15mm Screw	Tornillo 4x15mm	Cup Holder	Portavasos	Outer Leg Cap	Corra de pierna exterior
P5	FOR FIG. 2	P6	FOR FIG. 2	P7	FOR FIG. 2	P8	FOR FIG. 2
	x1		x1		x1		x1
Steel Wire - A	Cable de acero - A	Steel Wire - B	Cable de acero - B	Butterfly Nut	Tuerca de mariposa	M5 Nut	Tuerca M5
P9	FOR FIG. 2						
	x1						
M5 Spring Lock Washer	Arandela de cerradura de resorte M5						

BEFORE ASSEMBLY

ANTES DE MONTAR



1. Find a clean, level place to begin the assembly of your product.
2. Verify that you have all listed parts as shown on the part list page. If any parts are missing, call our customer service.

1. Encuentre un lugar limpio y nivelado para comenzar el ensamblaje del producto.
2. Compruebe que tenga todas las piezas que se muestran en la lista de piezas. Si falta alguna pieza, llame a nuestro servicio al cliente.

ASSEMBLY

MONTAJE

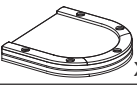



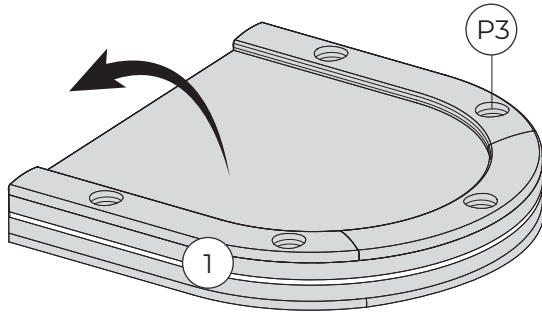



FIG. 1

-  1 x1
Pre-installed
-  P3 x10



Note: Unfold the Folded Poker Table (1).
 Nota: Abra la plegable mesa para póker (1).

FIG. 2

-  P1 x4
Pre-installed
-  P2 x16
-  P4 x4
Pre-installed
-  P5 x1
Pre-installed
-  P6 x1
Pre-installed
-  P7 x1
Pre-installed
-  P8 x1
Pre-installed
-  P9 x1
Pre-installed

Note: To unfold the legs - Make sure that the hinges are locked in the correct position.
 Nota: Para abrir las patas - Estar seguro de tener las bisagras cerradas en la correcta posición.

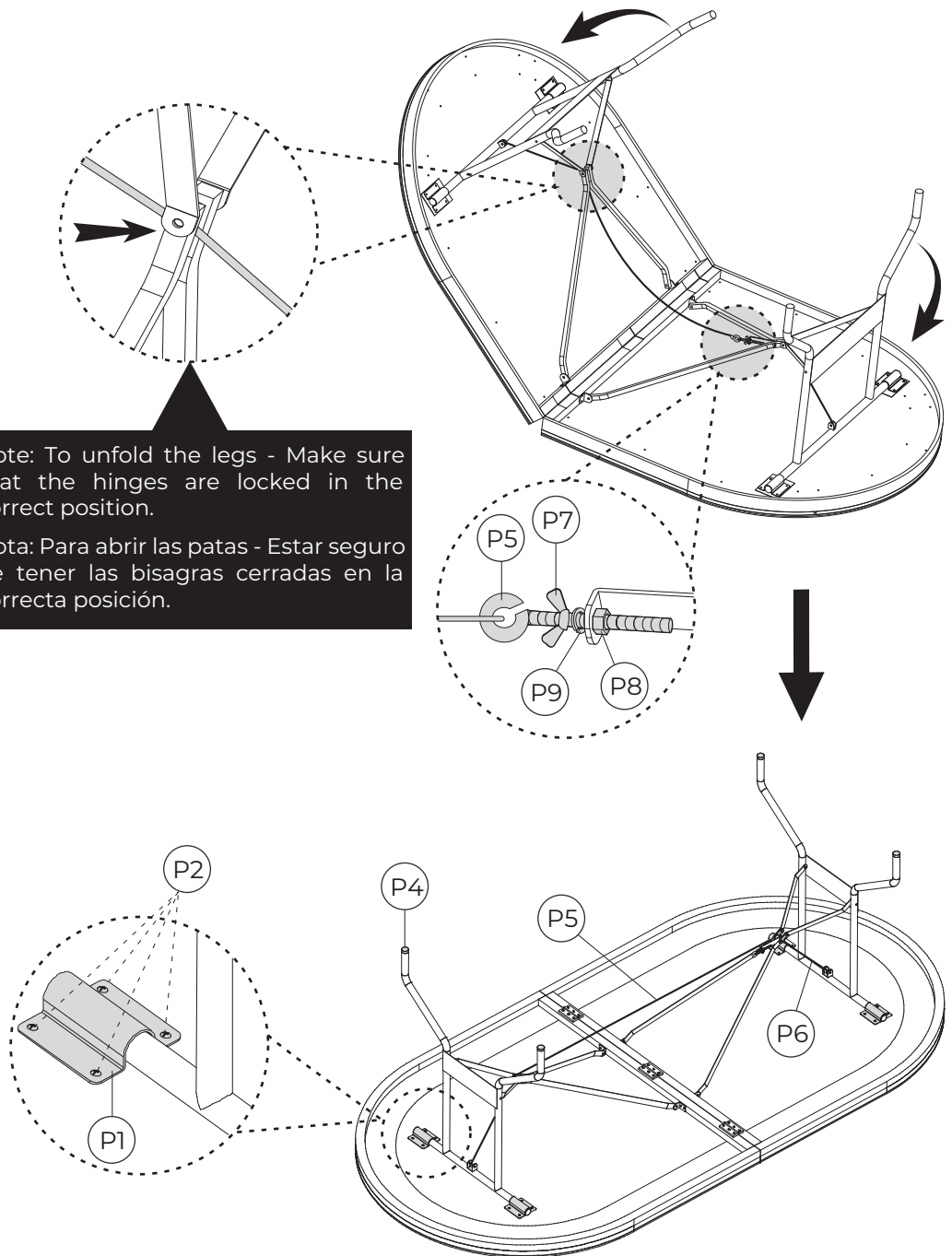

ASSEMBLY

MONTAJE

FIG. 3

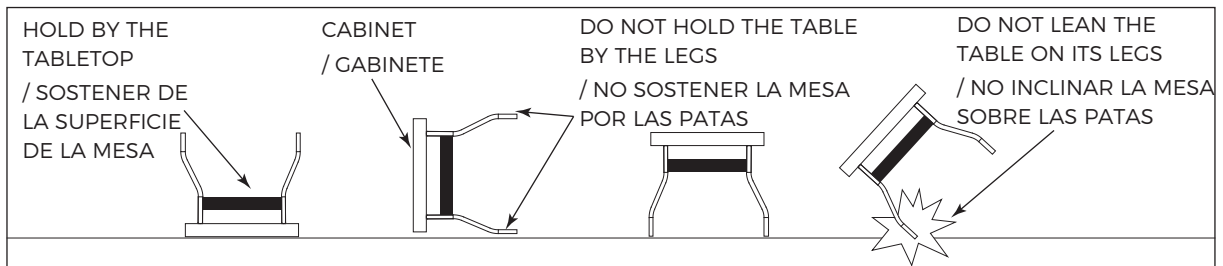
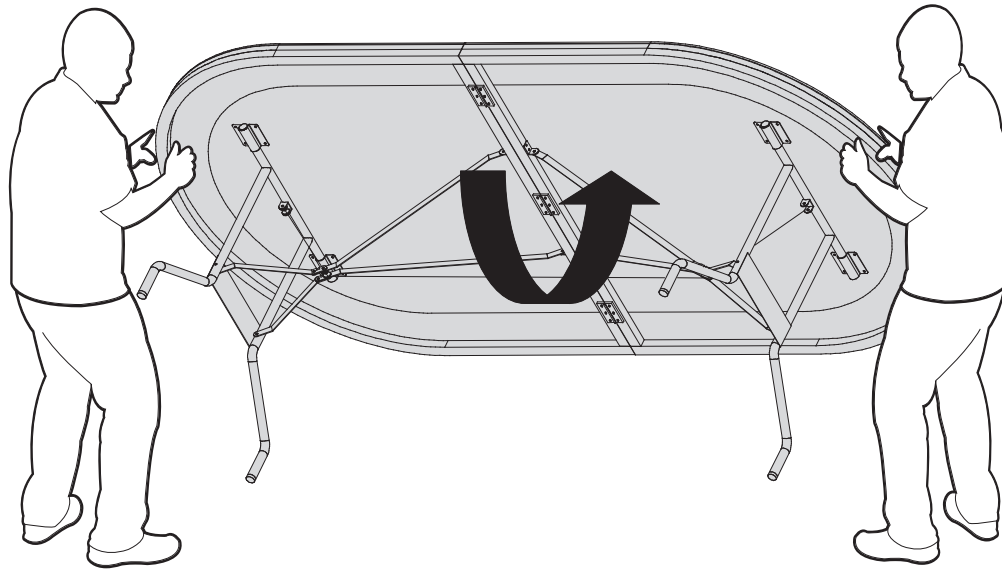

⚠ CAUTION

Two strong adults are recommended to turn over the table as shown.

1. Lift the table off the ground.
2. Turn the table over.
3. Place it on all feet at the same time on the ground.

⚠ PRECAUCIÓN

Se recomienda la participación de dos adultos para invertir la mesa como se muestra.

1. Levante la tabla del suelo.
2. Voltee la mesa.
3. Coloque las patas en el suelo al mismo tiempo.

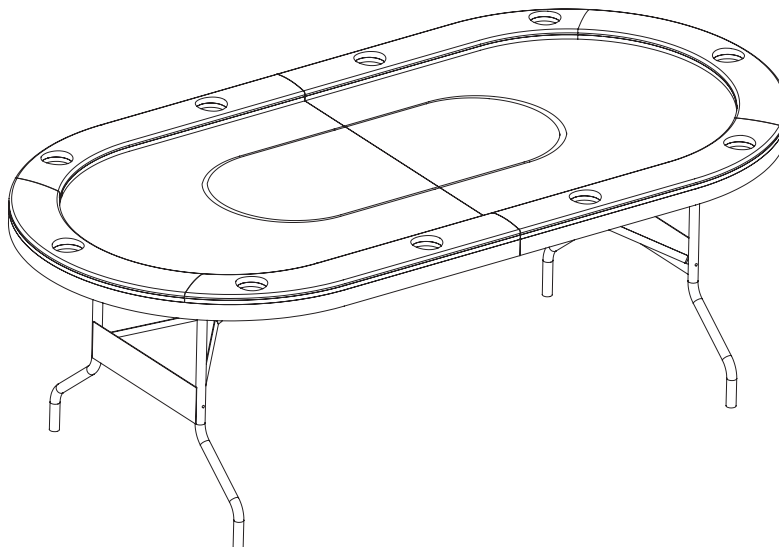

HOW TO LEVEL YOUR TABLE

CÓMO NIVELAR SU MESA

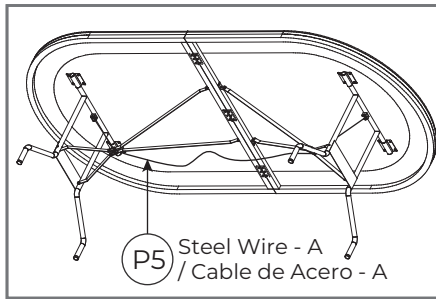
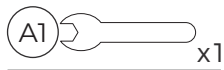

TIP

When the steel wire is too tight, place the side edge of the Table against the ground first (pay attention to protecting the product), then fold it inward and loosen the steel wire for adjustment.



CONSEJO

Quando el cable de acero esté demasiado apretado, coloque la mesa de lado apoyada sobre el suelo (no olvide proteger el producto), luego pliéguela hacia dentro y afloje el cable de acero para ajustarlo.

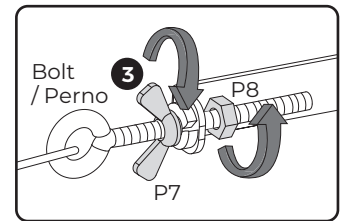
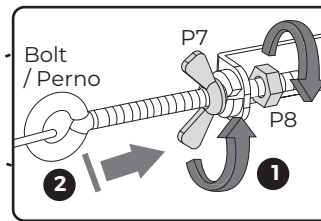
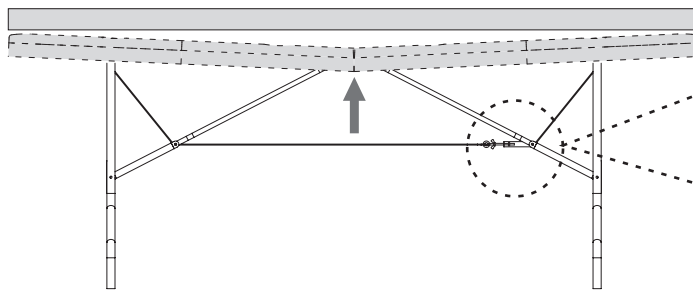

ADJUST CONCAVE TABLE

1. Loosen P7 and P8.
2. Push the Bolt inwards until the playfield is even.
3. Tighten P7 and P8.

AJUSTAR LA MESA CÓNCAVA

1. Afloje P7 y P8.
2. Empuje el Perno hacia dentro hasta que el campo esté a nivel.
3. Apriete P7 y P8.

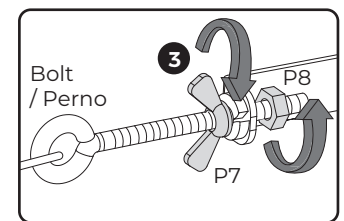
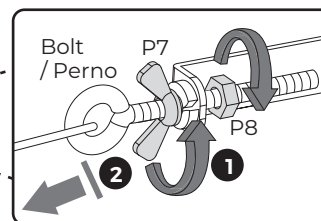
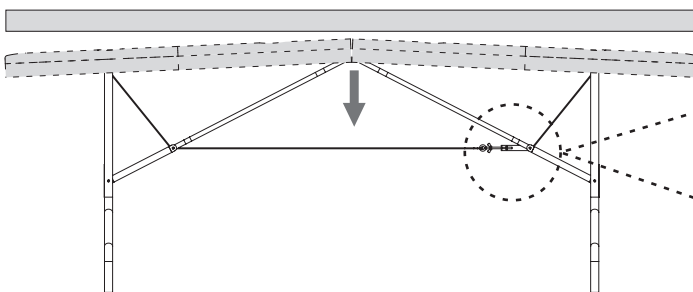

ADJUST CONVEX TABLE

1. Loosen P7 and P8.
2. Pull the Bolt outwards until the playfield is even.
3. Tighten P7 and P8.

AJUSTAR LA MESA CONVEXA

1. Afloje P7 y P8.
2. Tiras el Perno hacia fuera hasta que el campo esté a nivel.
3. Apriete P7 y P8.

