



**INSTRUCTIONS D'ASSEMBLAGE  
ASSEMBLY INSTRUCTIONS**

---

**TABLE A MANGER -  
36"X 60" / FAUX BOIS NOIR**

**DINING TABLE -  
36"X 60" / BLACK RECLAIMED WOOD-LOOK**



**POUR DE L'ASSISTANCE OU POUR COMMANDER  
DES PIÈCES CONTACTEZ NOTRE DÉPARTEMENT  
DE SERVICE À LA CLIENTÈLE.**

**FOR ASSISTANCE OR TO ORDER PARTS  
CONTACT OUR CUSTOMER SERVICE DEPARTMENT**

**LISTE DES PIÈCES**  
**PARTS LIST**

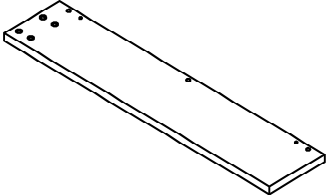
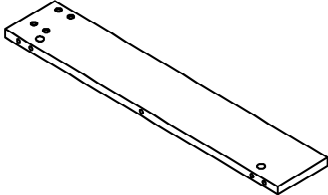
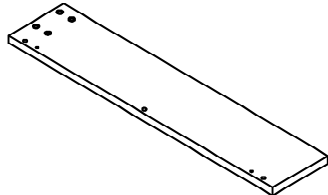
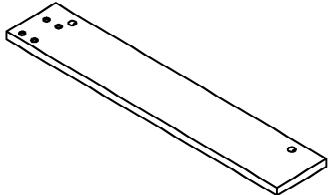
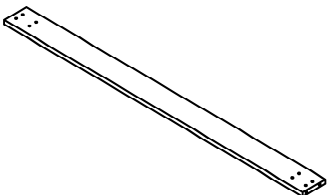
PIÈCE / PART #	IMAGE	DESCRIPTION	QTY / QTÉ
1		LEG PATTE	2
2		LEG PATTE	2
3		LEG PATTE	2
4		LEG PATTE	2
5		CROSSBAR BARRE TRANSVERSALE	2

**LISTE DES PIÈCES**  
**PARTS LIST**

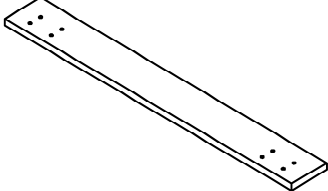
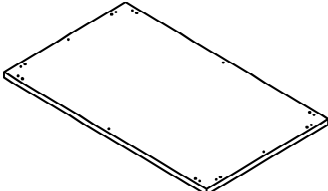
PIÈCE / PART #	IMAGE	DESCRIPTION	QTY / QTÉ
<b>6</b>		<b>CROSSBAR</b> <b>BARRE TRANSVERSALE</b>	<b>2</b>
<b>7</b>		<b>TABLE TOP</b> <b>SURFACE DE TABLE</b>	<b>1</b>

**LISTE DES PIÈCES DE MONTAGE**  
**HARDWARE LIST**

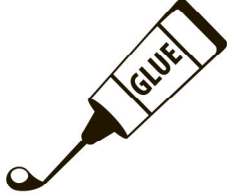
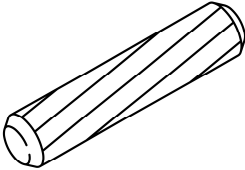
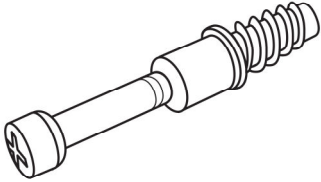
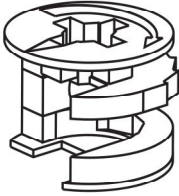
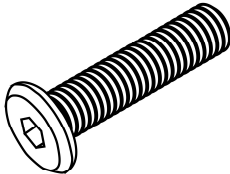
PIÈCE / PART #	IMAGE	DESCRIPTION	QTY / QTÉ
<b>A</b>		GLUE - 40G  COLLE - 40G	<b>1</b>
<b>B</b>		WOOD DOWEL - Ø3/8" X 1 1/8"  GOUJON DE BOIS - Ø3/8" X 1 1/8"	<b>28</b>
<b>C</b>		CAM LOCK SCREW - 1 3/8"  VIS CAM LOCK - 1 3/8"	<b>20</b>
<b>D</b>		CAM LOCK CONNECTOR - Ø5/8" X 1/2"  ÉCROU CAM LOCK - Ø5/8" X 1/2"	<b>20</b>
<b>E</b>		ASSEMBLING BOLT - 1 3/8"  BOULON D'ASSEMBLAGE - 1 3/8"	<b>32</b>

**LISTE DES PIÈCES DE MONTAGE**  
**HARDWARE LIST**

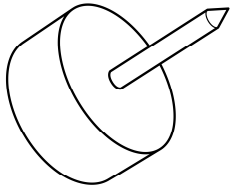
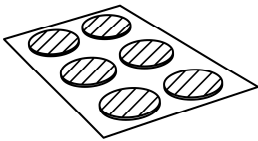
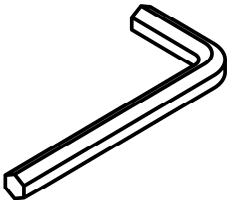
PIÈCE / PART #	IMAGE	DESCRIPTION	QTY / QTÉ
<b>F</b>		<b>FLOOR PROTECTOR - Ø3/4"</b> <b>PROTECTEUR DE PLANCHER - Ø3/4"</b>	<b>8</b>
<b>G</b>		<b>FINISHING STICKER - Ø3/4"</b> <b>COLLANT DE FINITION - Ø3/4"</b>	<b>20</b>
<b>H</b>		<b>HEX KEY</b> <b>CLÉ HEXAGONALE</b>	<b>1</b>

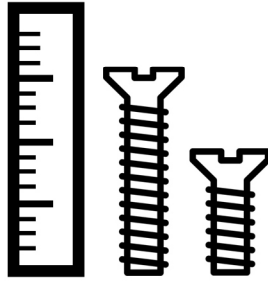

**OUTIL DE VÉRIFICATION DE DIMENSIONS DES PIÈCES  
HARDWARE DIMENSIONS VERIFICATION TOOL**

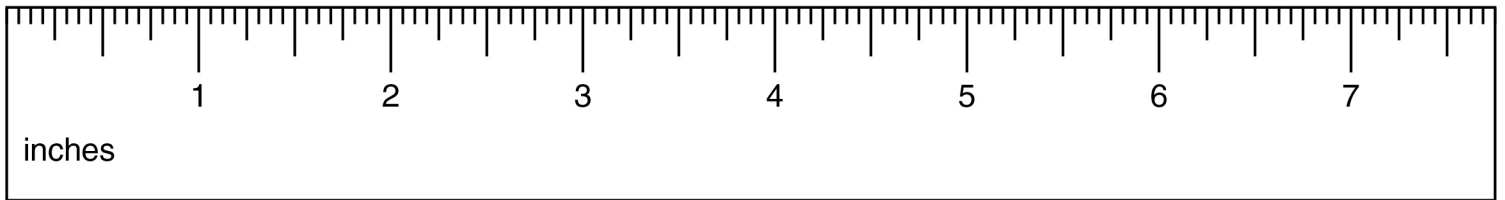

## ÉTAPE / STEP 1

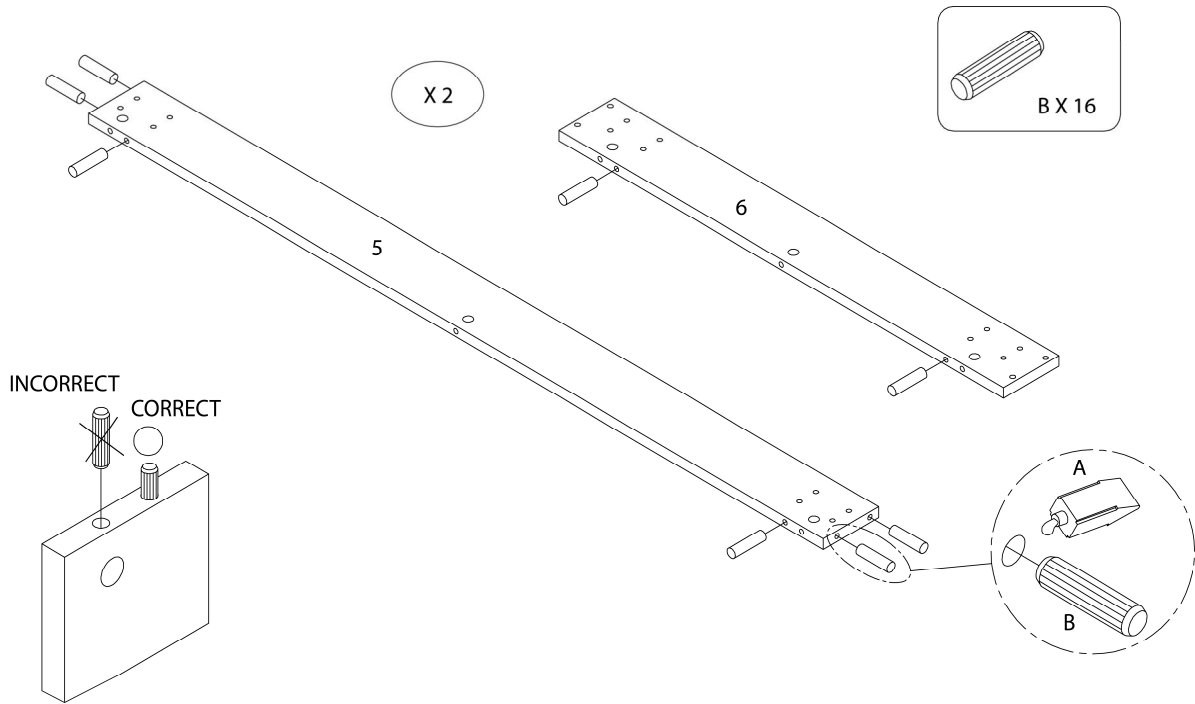

## ÉTAPE / STEP 2

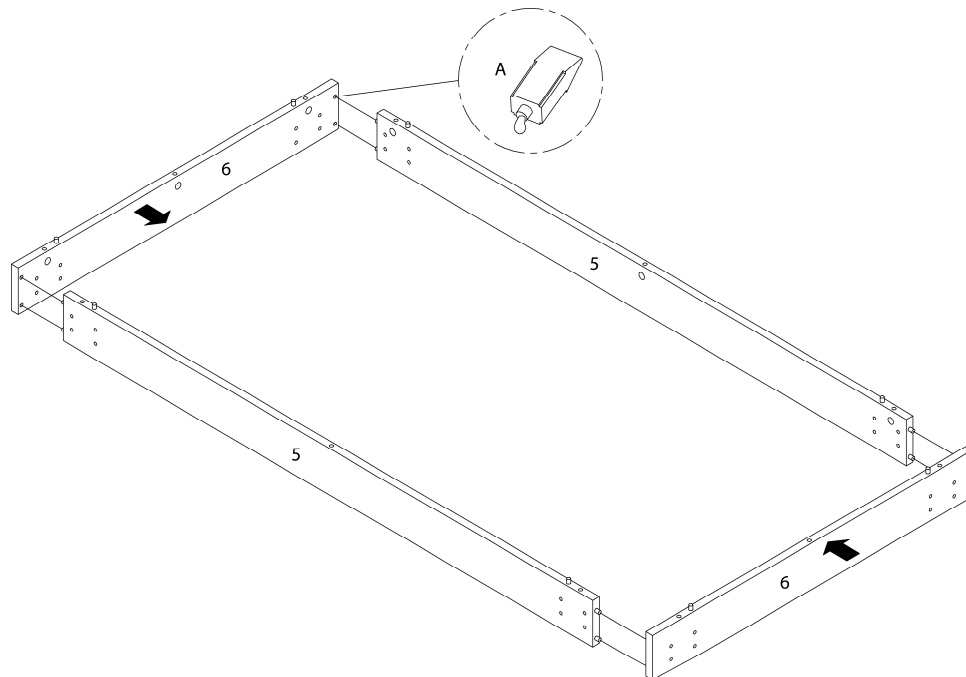

### ÉTAPE / STEP 3

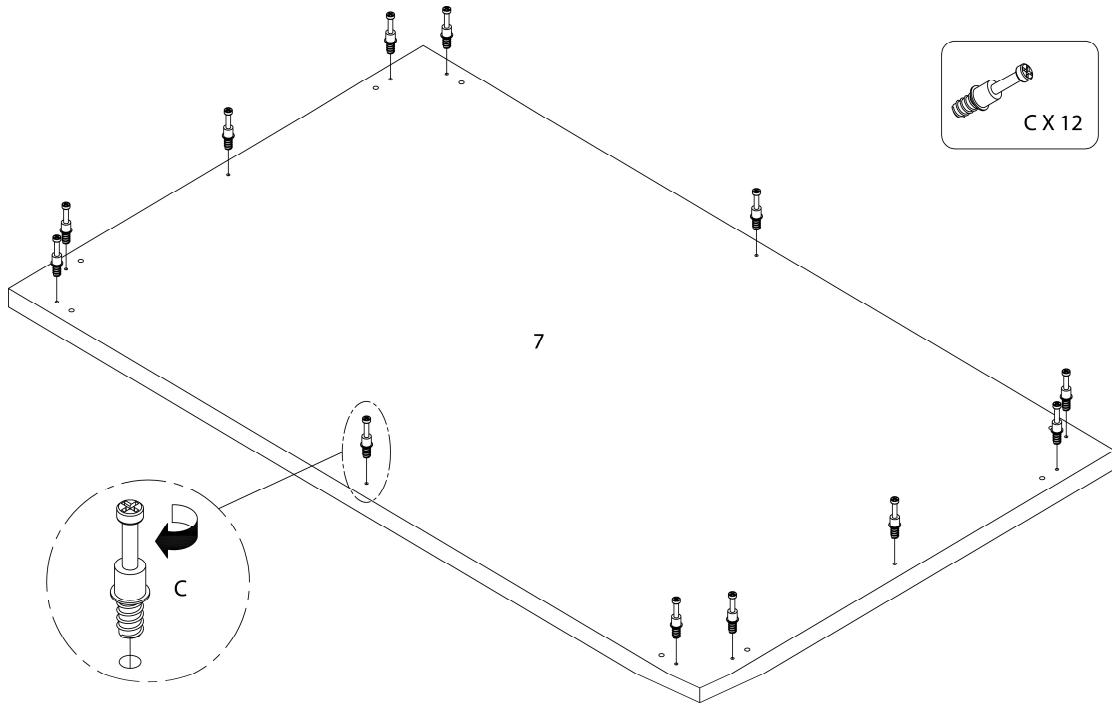

### ÉTAPE / STEP 4

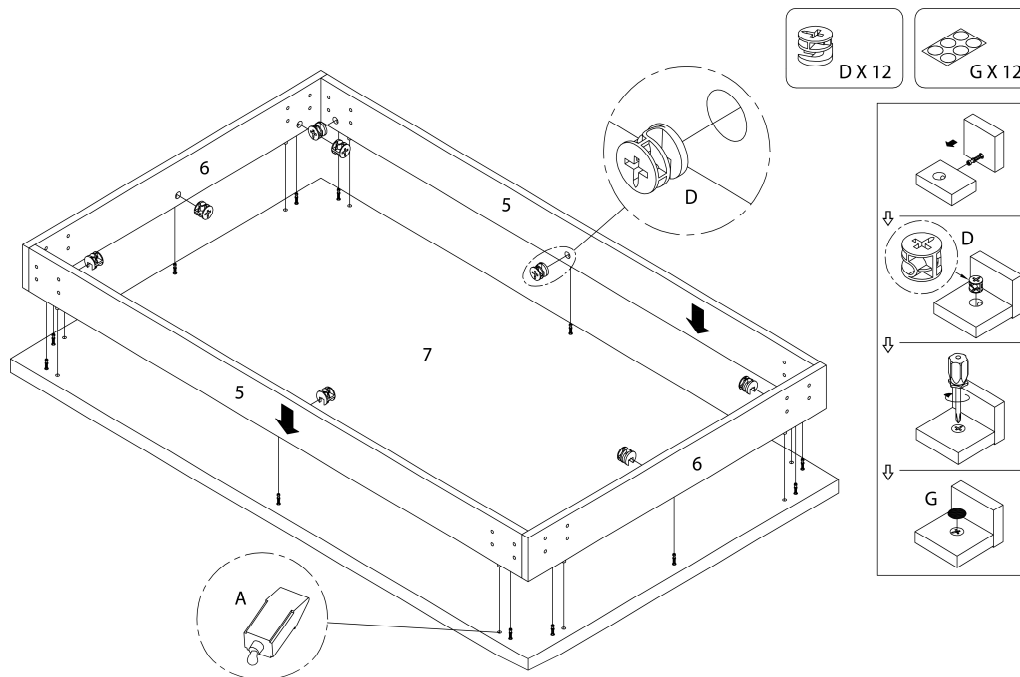

ÉTAPE / STEP 5

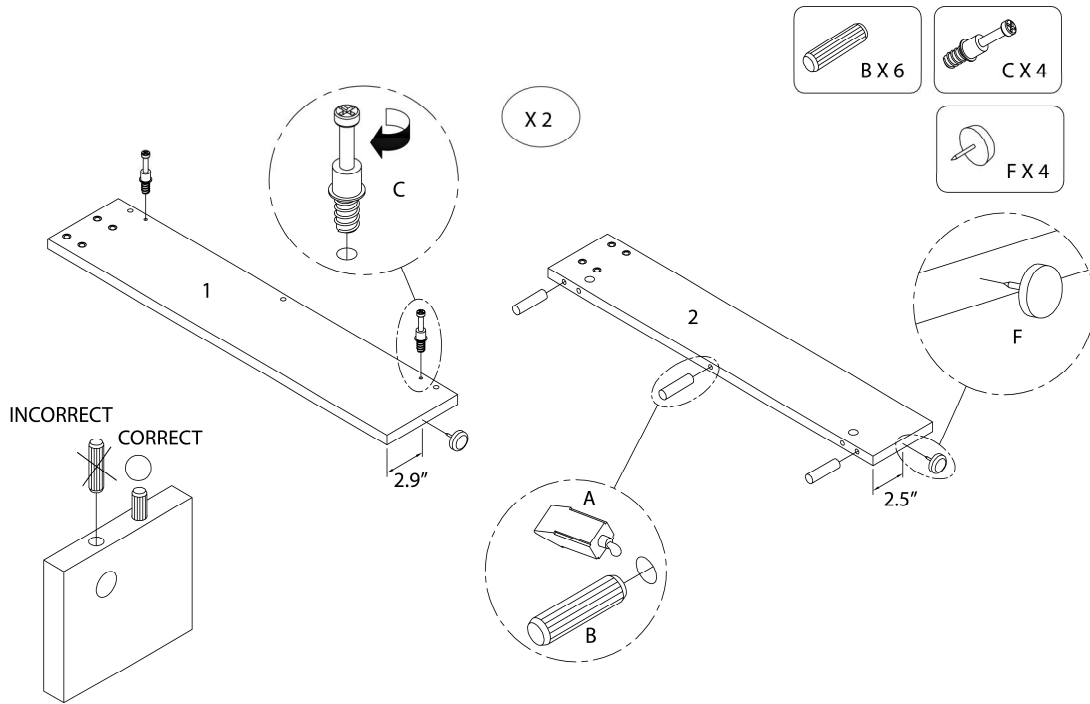

ÉTAPE / STEP 6

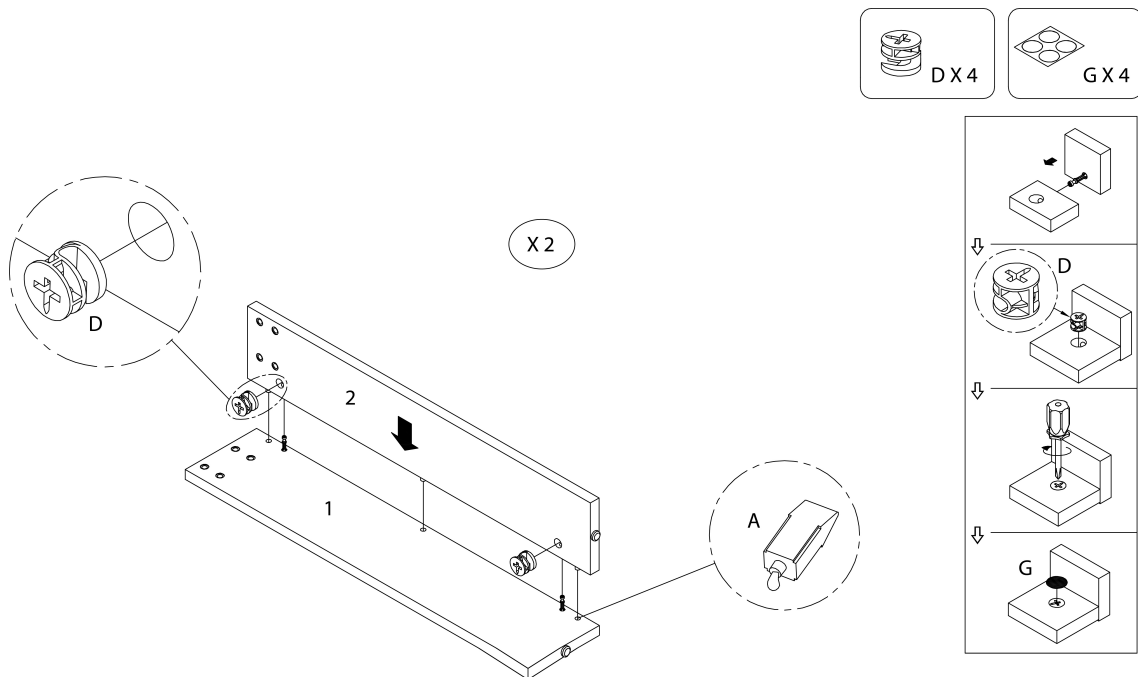

ÉTAPE / STEP 7

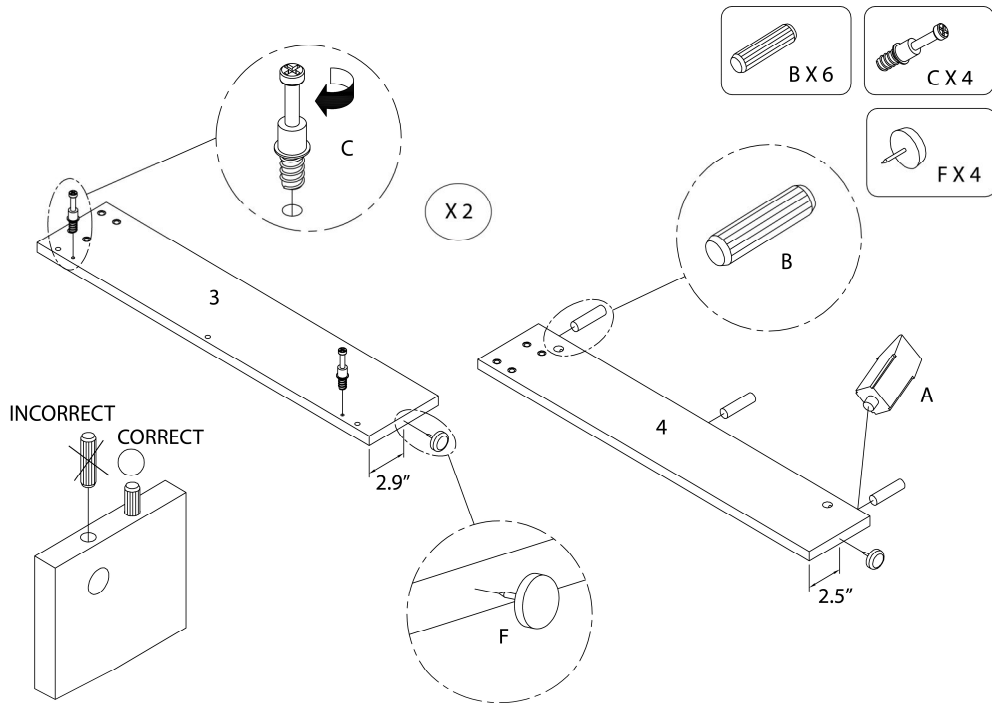

ÉTAPE / STEP 8

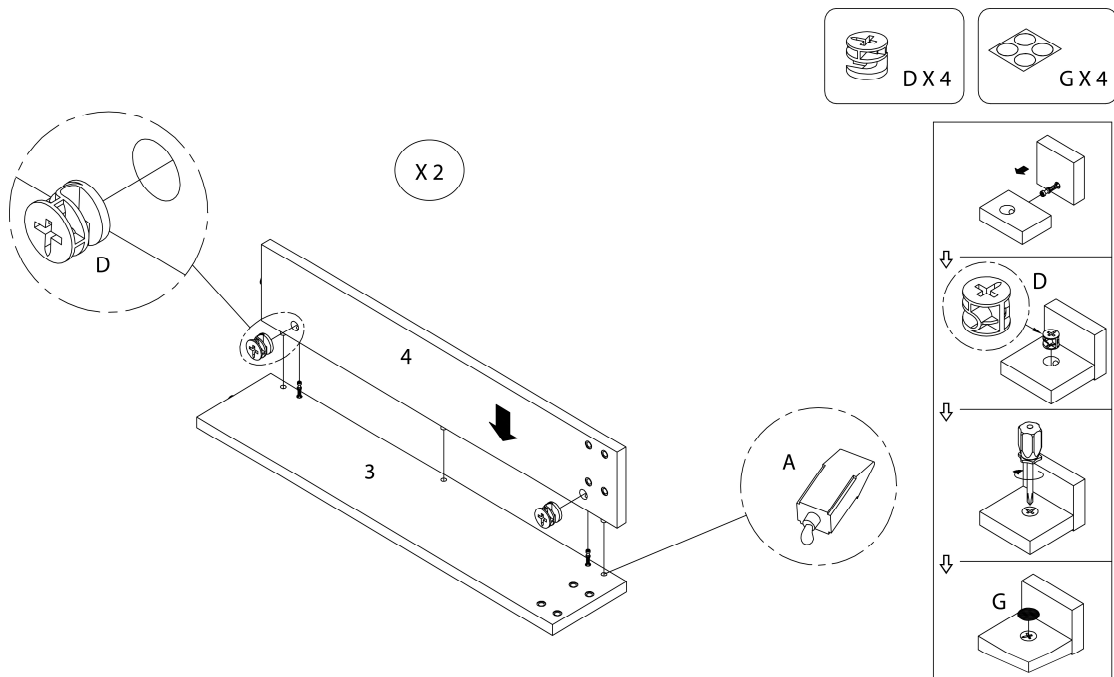

ÉTAPE / STEP 9

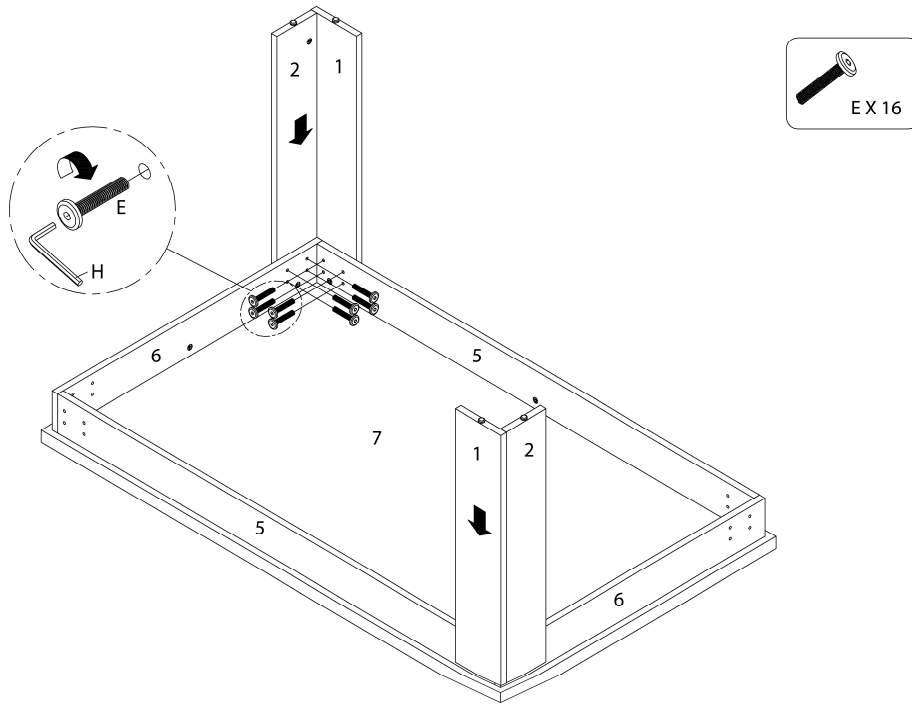

ÉTAPE / STEP 10

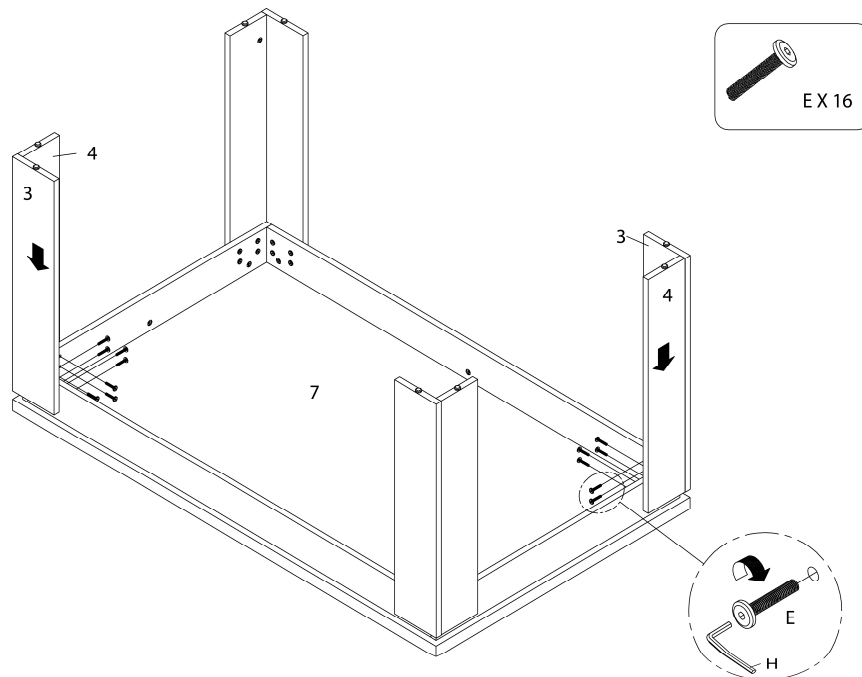

ÉTAPE / STEP 11

