



05 : 00

estimated
assembly time



1 or more

people required

Ok, let's
get started!



- Put on mood music!
- To prevent damage to product, use the clean side of package carton or rug as working surface.
- In the event of missing or damaged parts, delivery problems etc., please reach out to our team.
We will be happy to fix the problem!

care guide

- Clean regularly with a soft and dry cloth.
- To protect finish, avoid use of abrasive cleaners.
- Wipe up spills immediately. Please!



ⓘ **While assembling the product, tighten the bolts up to 50%. Once all parts are in place, only then fully tighten the bolts.**



product parts



(A)
Tabletop
x1



(B)
Table Base
x1

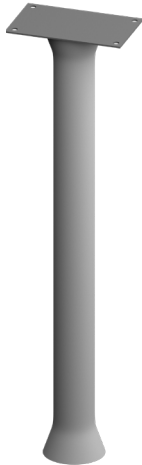

(C)
Table Leg
x1

what's included



(D)-Bolt (6x16mm)
x4

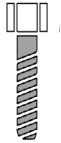

(E)-Bolt (6x30mm)
x2



(F)-Lock Washer
x6



(G)-Washer
x6



(H)-Allen key
x1

assembly instructions

Friendly Tip: Take a deep breath going in. This may be a tricky part, but nothing too overwhelming. Just follow these steps to the T and the outcome will be worth it!



- ⓘ While assembling the product, tighten the bolts up to 50%. Once all parts are in place, only then fully tighten the bolts.

step 1:

Start by placing the table top (A) upside down on a flat surface. Then place the table leg (C) upside down and align the slots on the legs with the holes on the table top. See this image for reference.

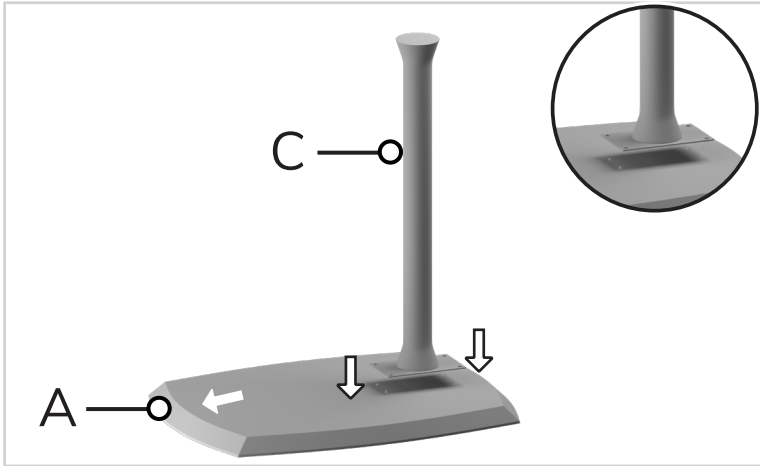

step 2:

Insert washer (G), lock washer (F) and bolt (D) on all four holes and fix them in place with the help of allen key (H).

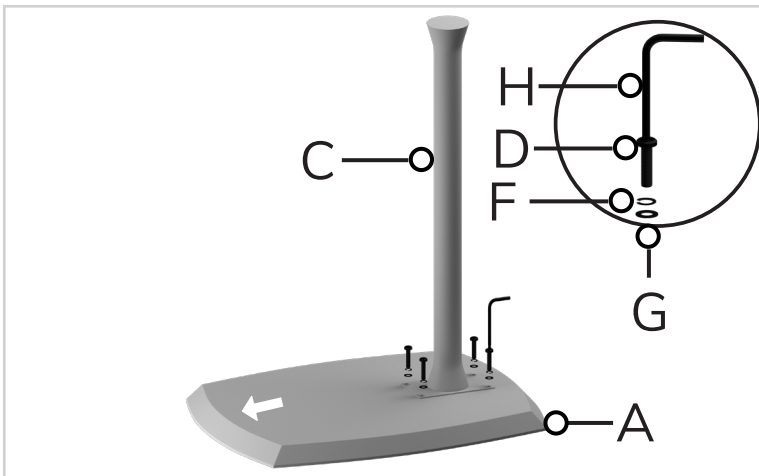

⚠ While assembling the product, tighten the bolts up to 50%. Once all parts are in place, only then fully tighten the bolts.

step 3:

Now, place the table base (B) upside down on the top of the pedestal (C). Insert washer (G), lock washer (F) and bolts (E) and tighten them up to 50% using allen key (H). During the assembly, make sure the stickers placed on

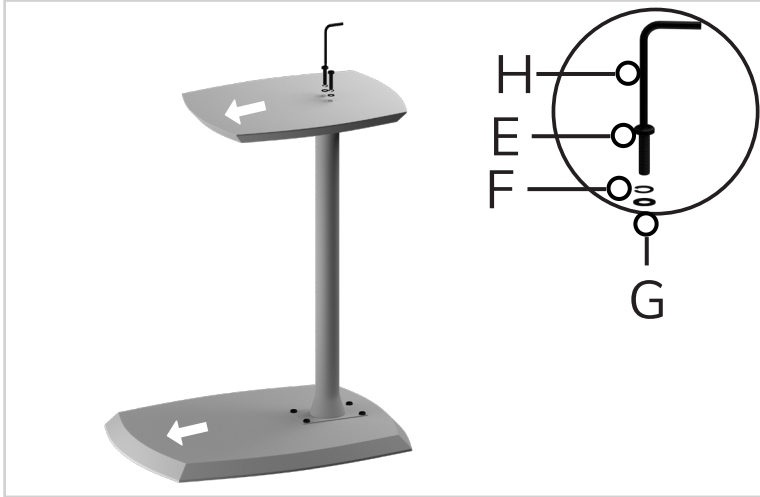

step 4:

Make sure the top and base are parallel to each other. Adjust if needed. When done, tighten all the bolts fully up to 100% and flip the table upside down.





Voilà! Your table is now assembled and secure!