

Termini Wide

Assembly guide

Please Read Our Introduction



EN

Valued Customer,
We design and carefully manufacture our products for our customers, We wish that our customers to have fun while they are doing their new furniture

The product you just purchased was subjected to all sorts of tests and controls before sending out to you.

Hope you enjoy your new furniture!!!

ES

Ciente valioso,
Diseñamos y fabricamos cuidadosamente nuestros productos para nuestros clientes, Deseamos que nuestros clientes se diviertan mientras hacen sus nuevos muebles

El producto que acaba de adquirir ha sido sometido a todo tipo de pruebas y controles antes de ser enviado a usted.

Esperamos que disfrute con sus nuevos muebles!!!

DE

Schätzbarer Kunde,
Wir entwerfen und fertigen unsere Produkte sorgfältig für unsere Kunden und möchten, dass unsere Kunden Spaß an ihren neuen Möbeln haben.

Das Produkt, das Sie soeben gekauft haben, hat alle möglichen Tests und Kontrollen durchlaufen, bevor es an Sie versandt wurde.

Wir wünschen Ihnen viel Freude mit Ihren neuen Möbeln!!!!



EN

Although all products are carefully manufactured and packed, sometimes we experience damage during transportation.

In such cases, please check the damaged part, note the part number written on the part and do not hesitate to contact us

ES

Aunque todos los productos se fabrican y embalan cuidadosamente, a veces se producen daños durante el transporte.

En estos casos, por favor, compruebe la pieza dañada, anote el número de pieza escrito en la misma y no dude en ponerse en contacto con nosotros.

DE

Obwohl alle Produkte sorgfältig hergestellt und verpackt werden, kommt es manchmal zu Transportschäden.

In diesen Fällen überprüfen Sie bitte das beschädigte Teil, notieren Sie die darauf vermerkte Teilenummer und zögern Sie nicht, uns zu kontaktieren.



EN

Furniture parts are going to several manufacturing procedures. During this process, parts can have little dust or marks. Please clean the parts with damp cloth before assembly to get the best result. Usual cleaning would be suffice.

ES

Las piezas de los muebles se someten a varios procedimientos de fabricación. Durante este proceso, las piezas pueden tener poco polvo o marcas. Por favor, limpie las piezas con un paño antes del montaje para obtener el mejor resultado. La limpieza habitual sería suficiente.

DE

Möbelteile durchlaufen verschiedene Herstellungsprozesse. Während dieses Vorgangs können die Teile etwas Staub oder Flecken aufweisen. Bitte wischen Sie die Teile vor dem Zusammenbau mit einem Tuch ab, um das beste Ergebnis zu erzielen. Die übliche Reinigung würde ausreichen.



EN

Before starting, please check all components and accessories according to the provided list. If you purchased more than one product, to prevent confusion, be sure that you completed the first product, then start the next one. Please make sure that you select correct numbered part and use specific connector to assemble. We do not recommend any modification or rotation in assembly. Please follow the manual carefully.

ES

Antes de comenzar, por favor, compruebe todos los componentes y accesorios de acuerdo con la lista proporcionada. Si ha comprado más de un producto, para evitar confusiones, asegúrese de que ha completado el primer producto y luego empiece con el siguiente. Por favor, asegúrese de seleccionar la pieza numerada correcta y de utilizar el conector específico para el montaje. No recomendamos ninguna modificación o rotación en el montaje. Por favor, siga el manual cuidadosamente.

DE

Bevor Sie beginnen, überprüfen Sie bitte alle Komponenten und Zubehörteile anhand der mitgelieferten Liste. Wenn Sie mehr als ein Produkt gekauft haben, vergewissern Sie sich bitte, dass Sie das erste Produkt abgeschlossen haben und beginnen Sie dann mit dem nächsten. Achten Sie bitte darauf, dass Sie das richtige nummerierte Teil auswählen und den entsprechenden Stecker für die Montage verwenden. Wir empfehlen keine Änderungen oder Drehungen an der Montage. Bitte beachten Sie das Handbuch sorgfältig.



EN

Do not use your furniture for out of purposes. If you would like to use it out of purpose or would like to do some modification or rotation, please contact us for more details.

Please do not expose your furniture with excessive heat, cold and humidity because product can be affected negatively.

ES

No utilice sus muebles para fines distintos.

Si desea utilizarlo fuera de propósito o le gustaría hacer alguna modificación o rotación, por favor póngase en contacto con nosotros para más detalles.

Por favor, no exponga sus muebles al calor, frío y humedad excesivos porque el producto puede verse afectado negativamente.

DE

Verwenden Sie Ihre Möbel nicht für andere Zwecke.

Wenn Sie es zweckentfremden oder eine Änderung oder Drehung vornehmen möchten, wenden Sie sich bitte an uns, um weitere Einzelheiten zu erfahren.

Bitte setzen Sie Ihre Möbel nicht übermäßiger Hitze, Kälte und Feuchtigkeit aus, da dies dem Produkt schaden könnte.

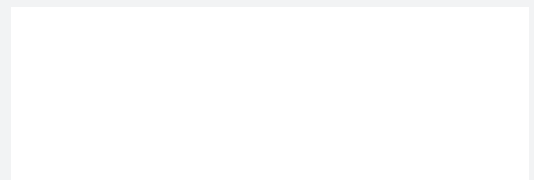

Prepare To Start

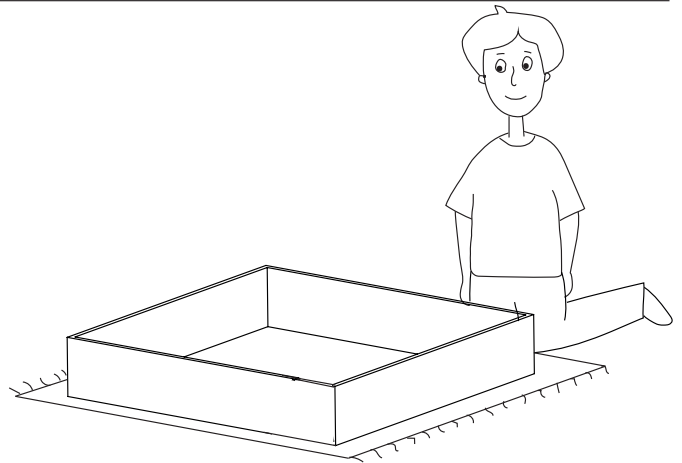
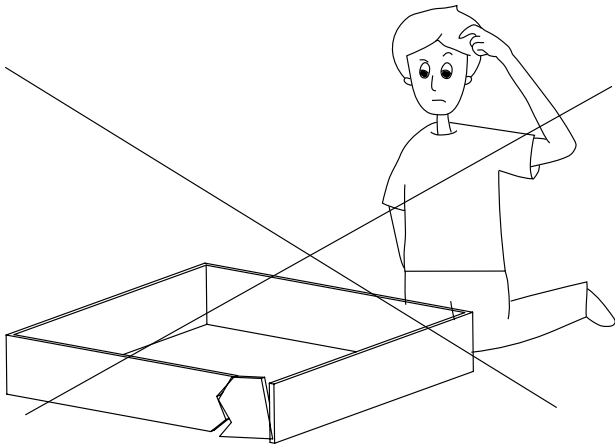
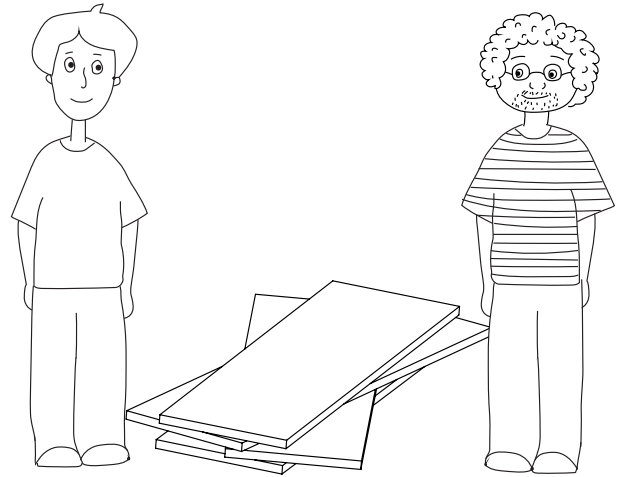
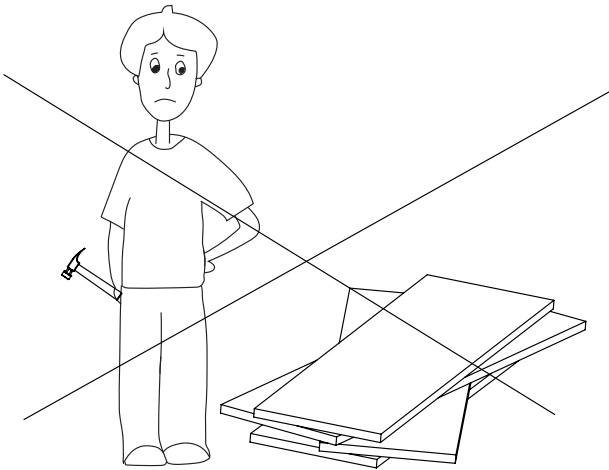
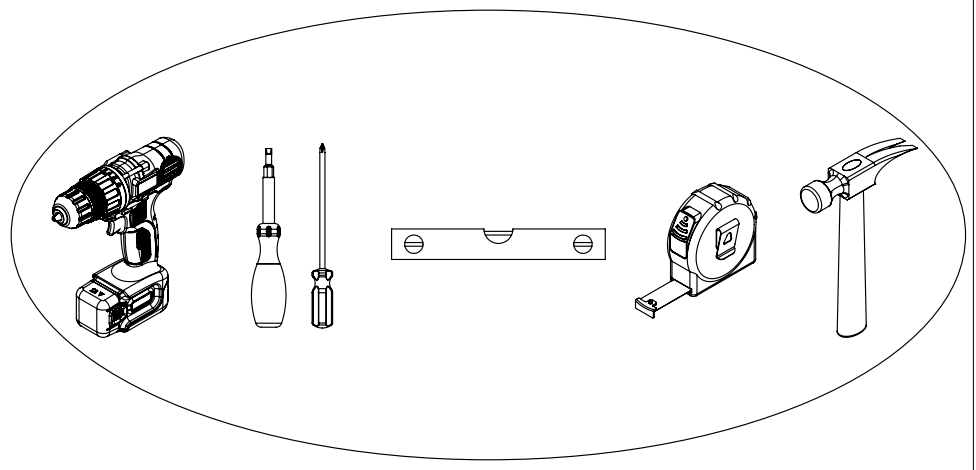
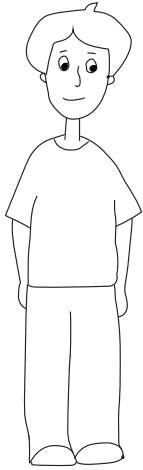





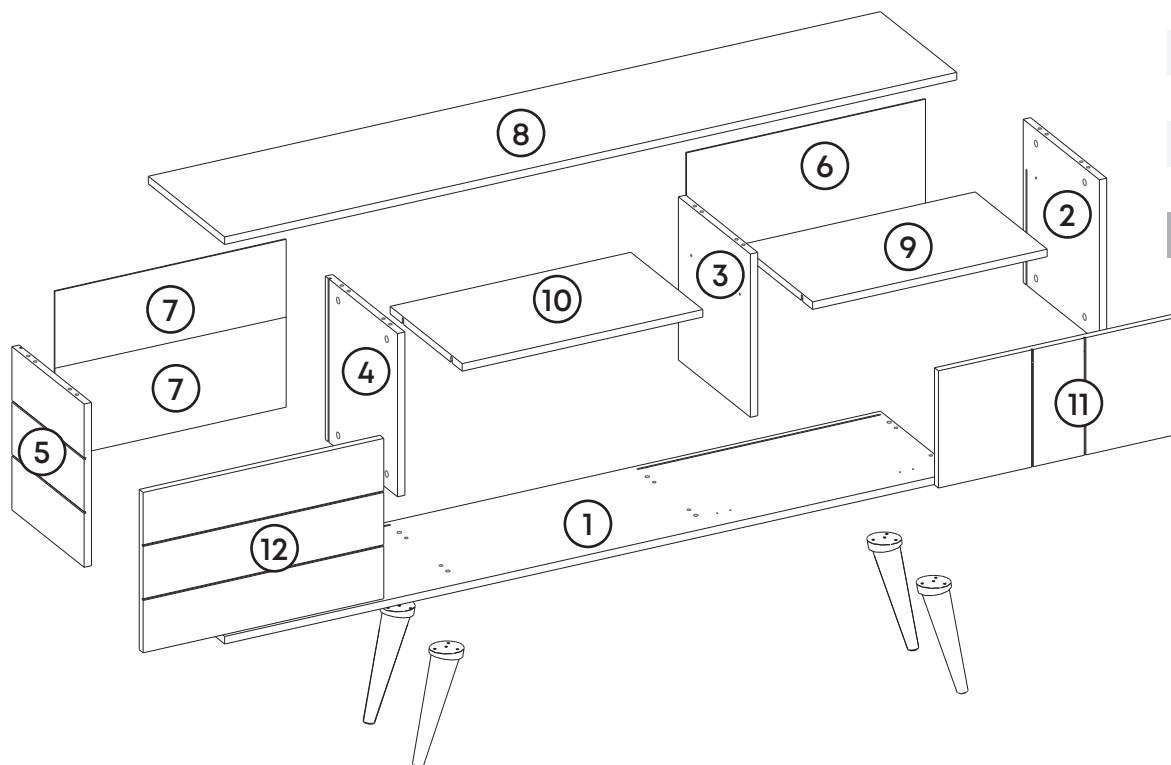

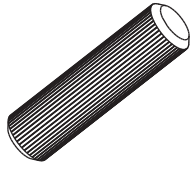
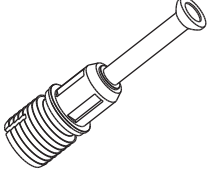
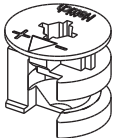
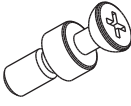

Components

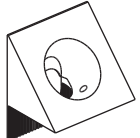
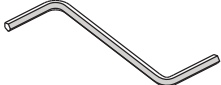
Part1	1x
Part2	1x
Part3	1x
Part4	1x
Part5	1x
Part6	1x
Part7	2x
Part8	1x
Part9	1x
Part10	1x
Part11	1x
Part12	1x
Total	13x

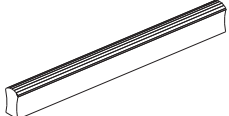

Accessory Parts

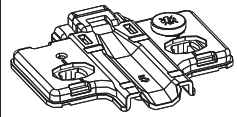
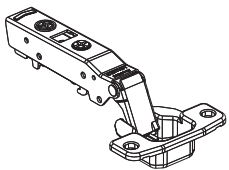
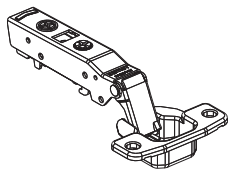
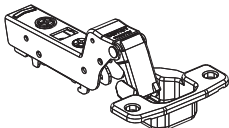
A01  Dowel Q8 16x	A02  Minifix Screw 16x	A03  Minifix Head 16x	A04  Rafix Screw 8x	A06  Pvc Sticker 16x	A08  Nail 14x
A09  Allen 1x	A13  Handle Screw 4x	A14  Handle 2x	A15  Leg 4x	A16  Piston 1x	A17  3,5 x 16 Screw 34x
A20  3,5 x 25 Screw 12x	A28  Hinge Base 4x	A29  Flat Hinge 1x	A30  Flat Hinge Brake 1x	A33  Full Hinge 2x	

How to instal Components

*Minifix is the main connection component used in Minima products. Before starting, please check the below figures

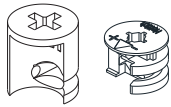

MINIFIX
HEAD

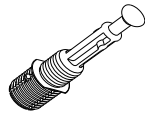

MINIFIX
SCREW



DOWEL

If the dowel is not required during the installation phase, it is not included in the package.

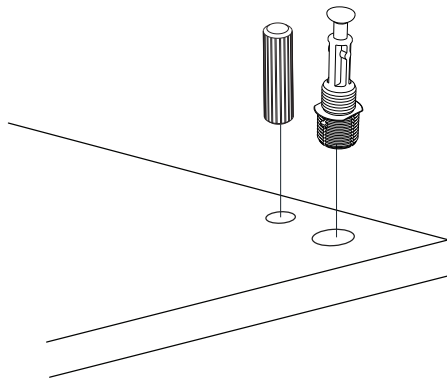

*Please notice that there is an small arrow on A03 (minifix head). This arrow should show the direction of upper hole.

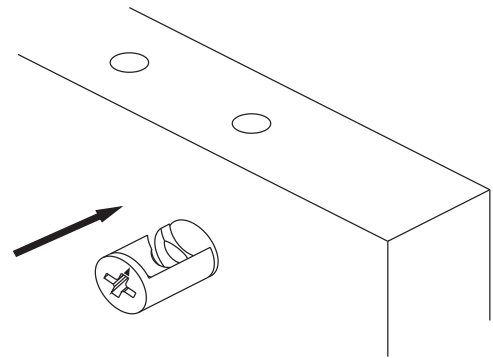

*After attaching two pieces please turn the A03 (minifix head) clockwise direction with the help of a screwdriver.

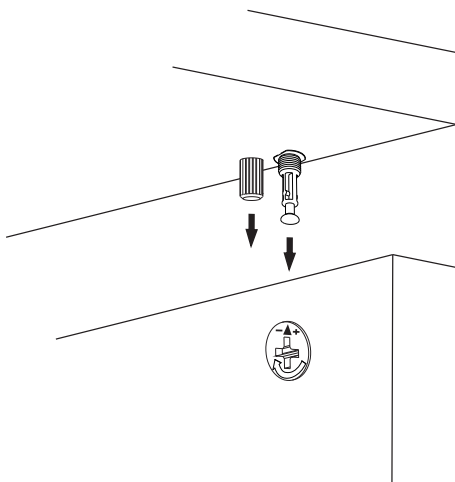

*Please do not over screw the minifix head since it may be broken if too much power is imposed. Just make sure that it is screwed to the direction "+" do not go any further.

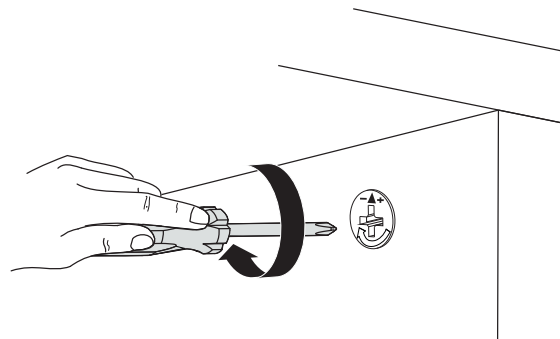

Note for Minifix Installation: Ensure the small arrow on the Minifix head (A03) points directly toward the edge hole where the Minifix screw (A02) enters. Once inserted, turn the head clockwise until it stops (usually a half-turn)—do not over-tighten, as forcing it past the "+" position can break the fitting.

1.

When attaching the legs (A20) to the bottom panel (Part 1), ensure the angled taper of the legs points outward toward the corners of the unit for maximum stability and proper styling.

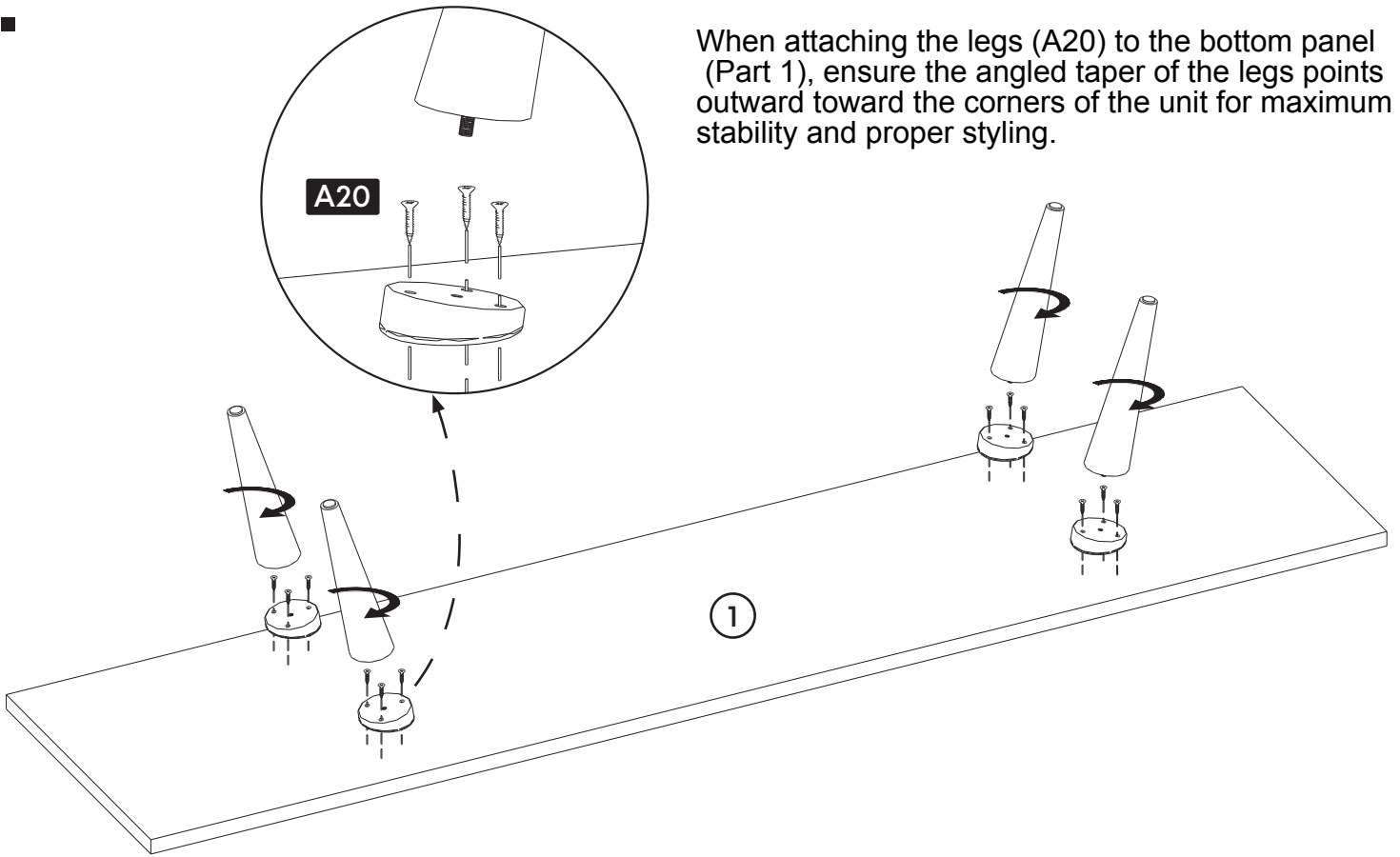

2.

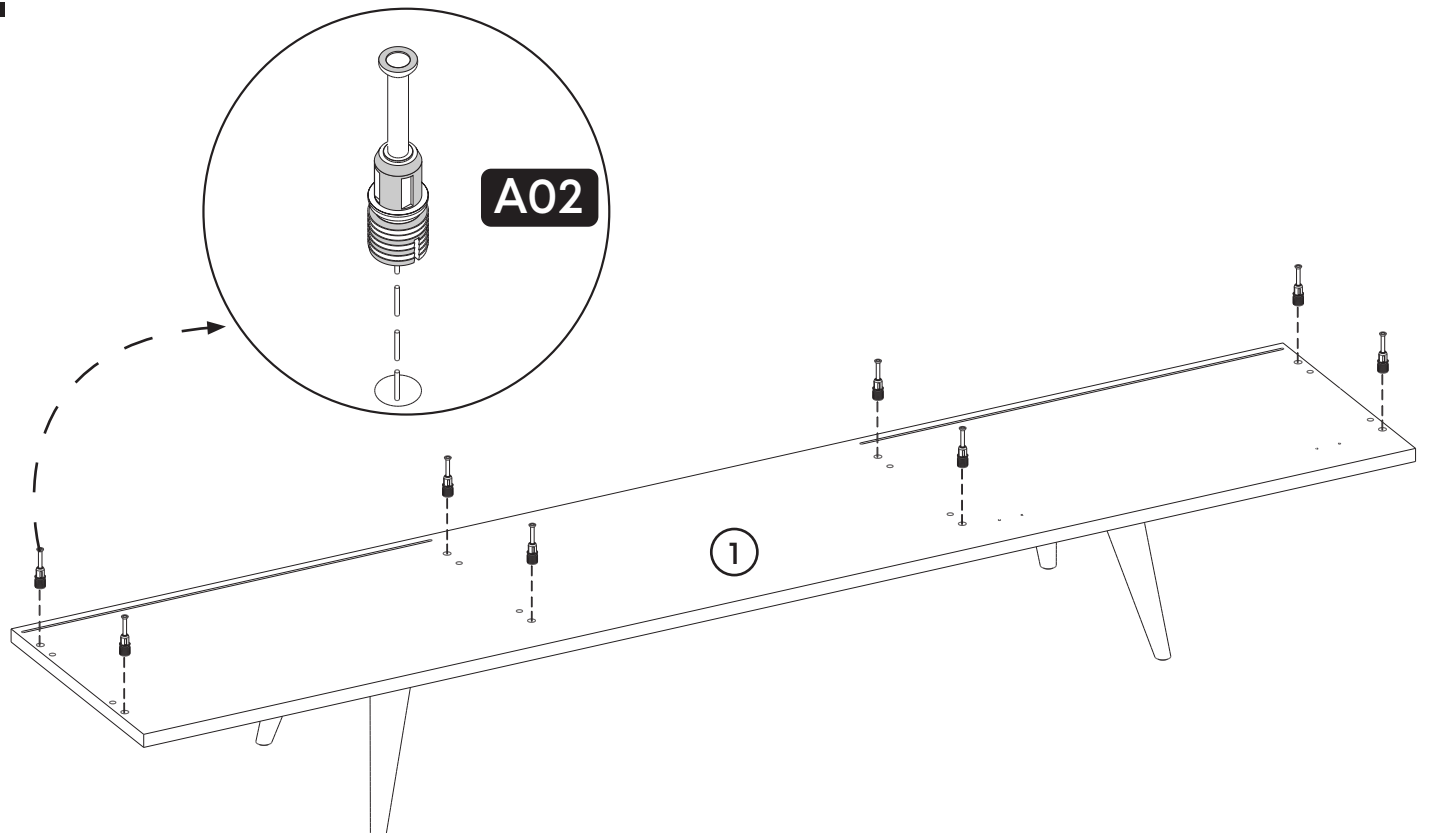

3.

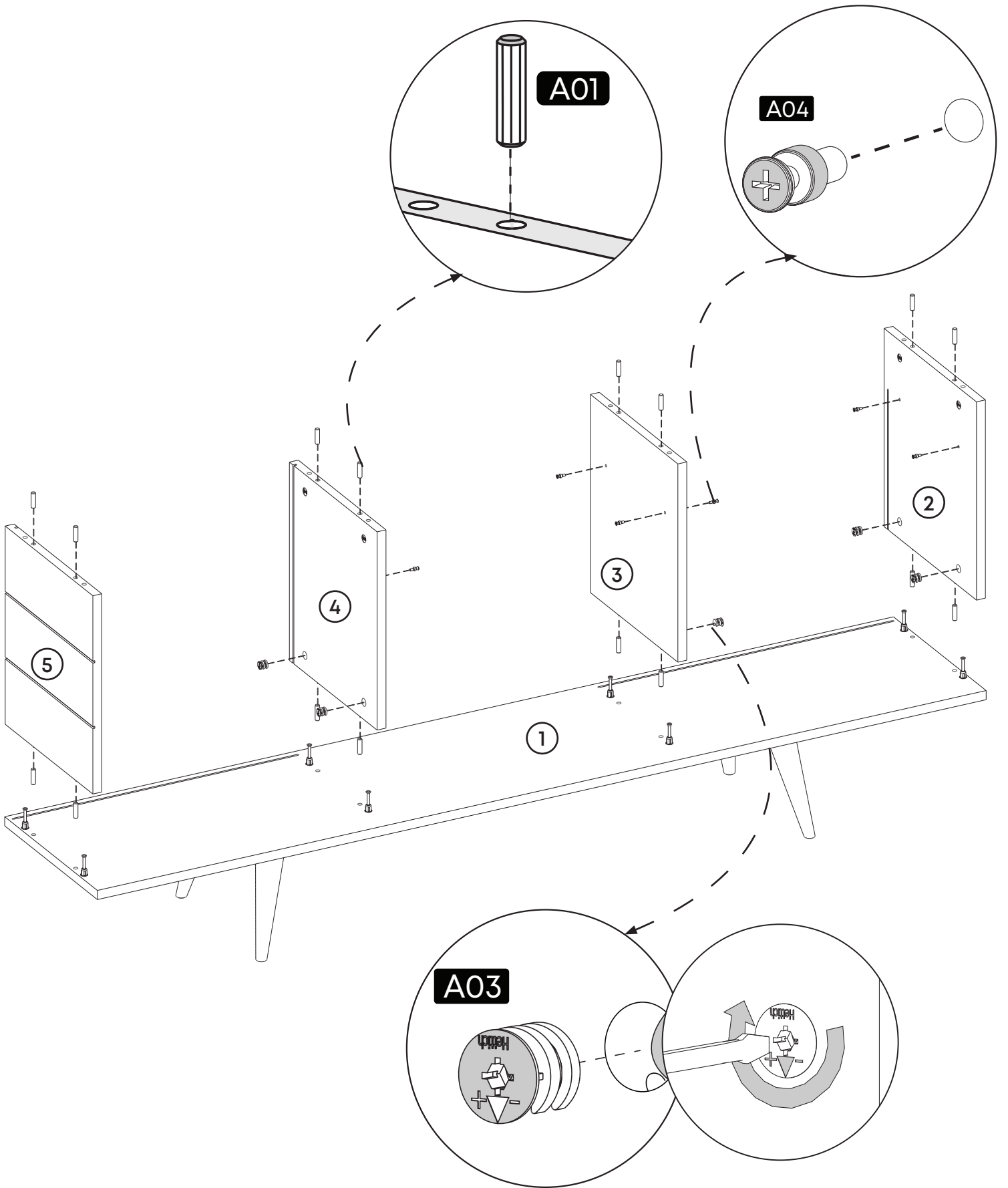

4.

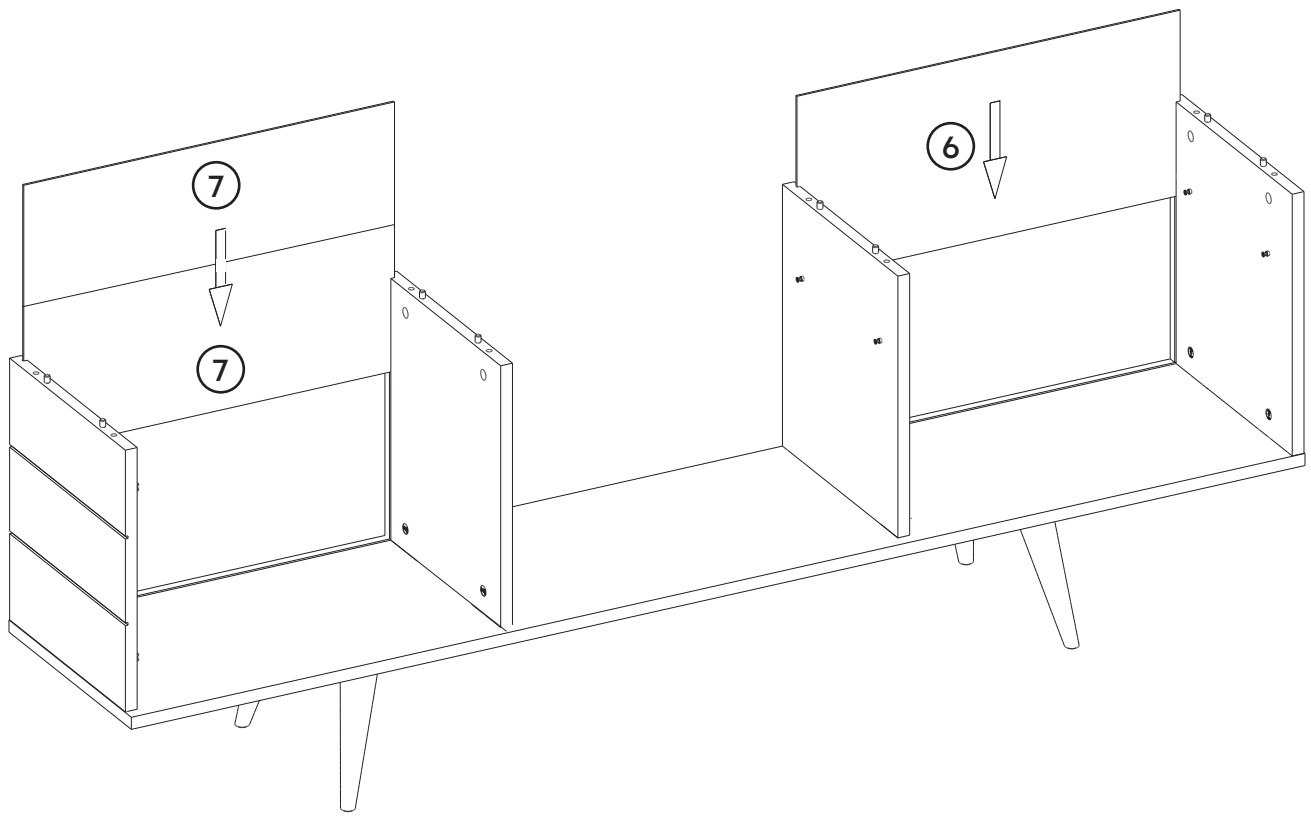

5.

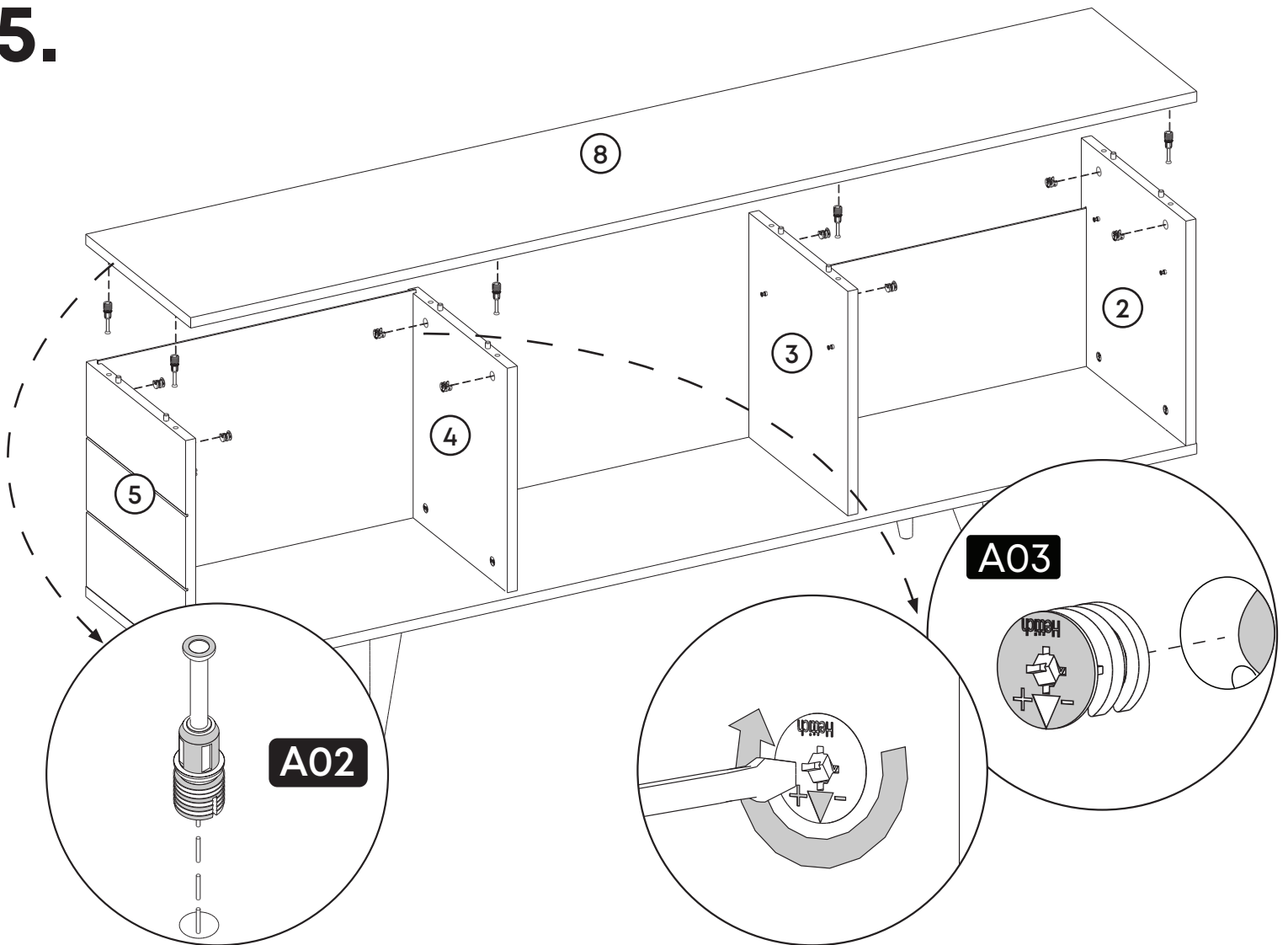

6.

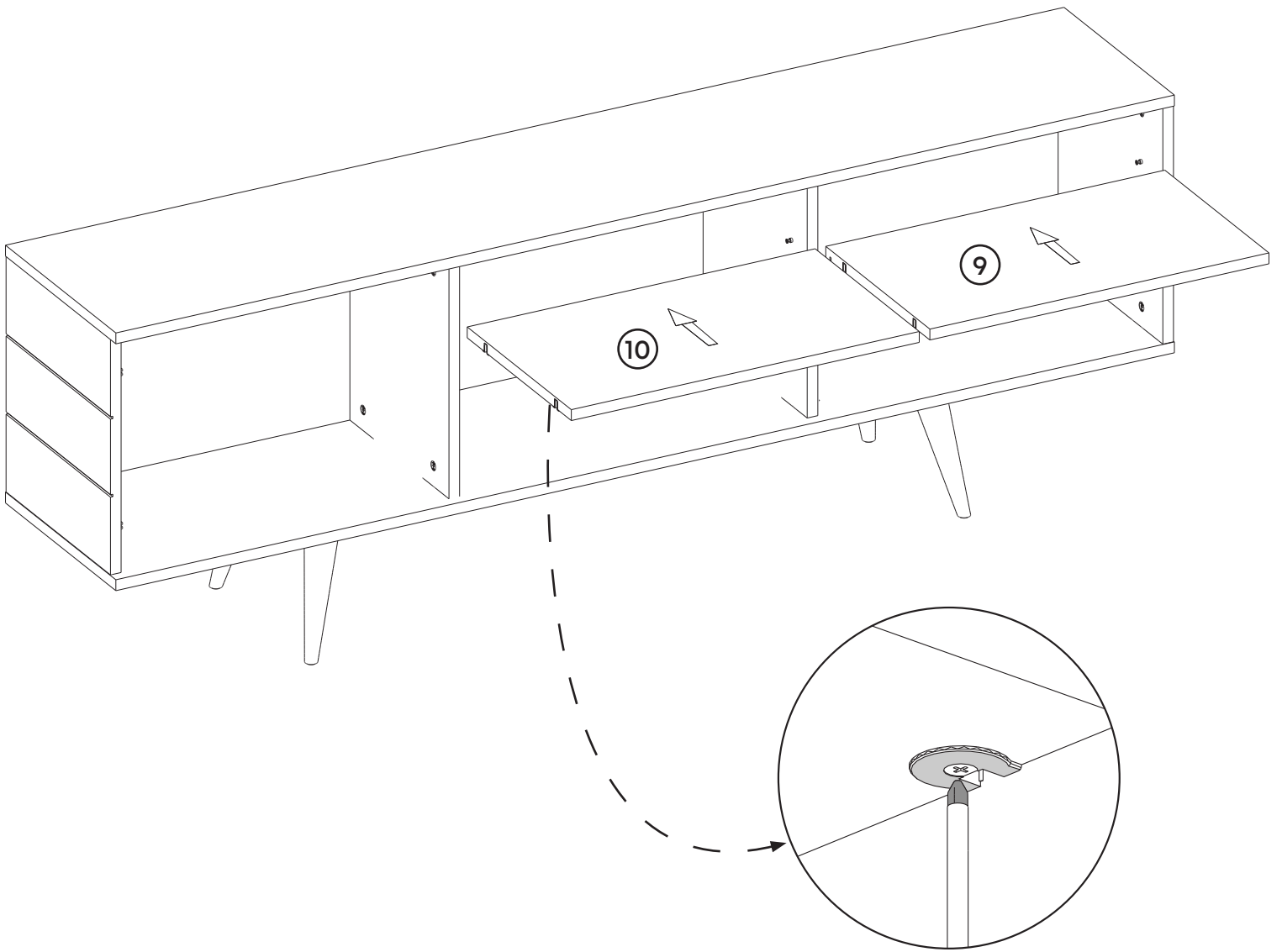

7.

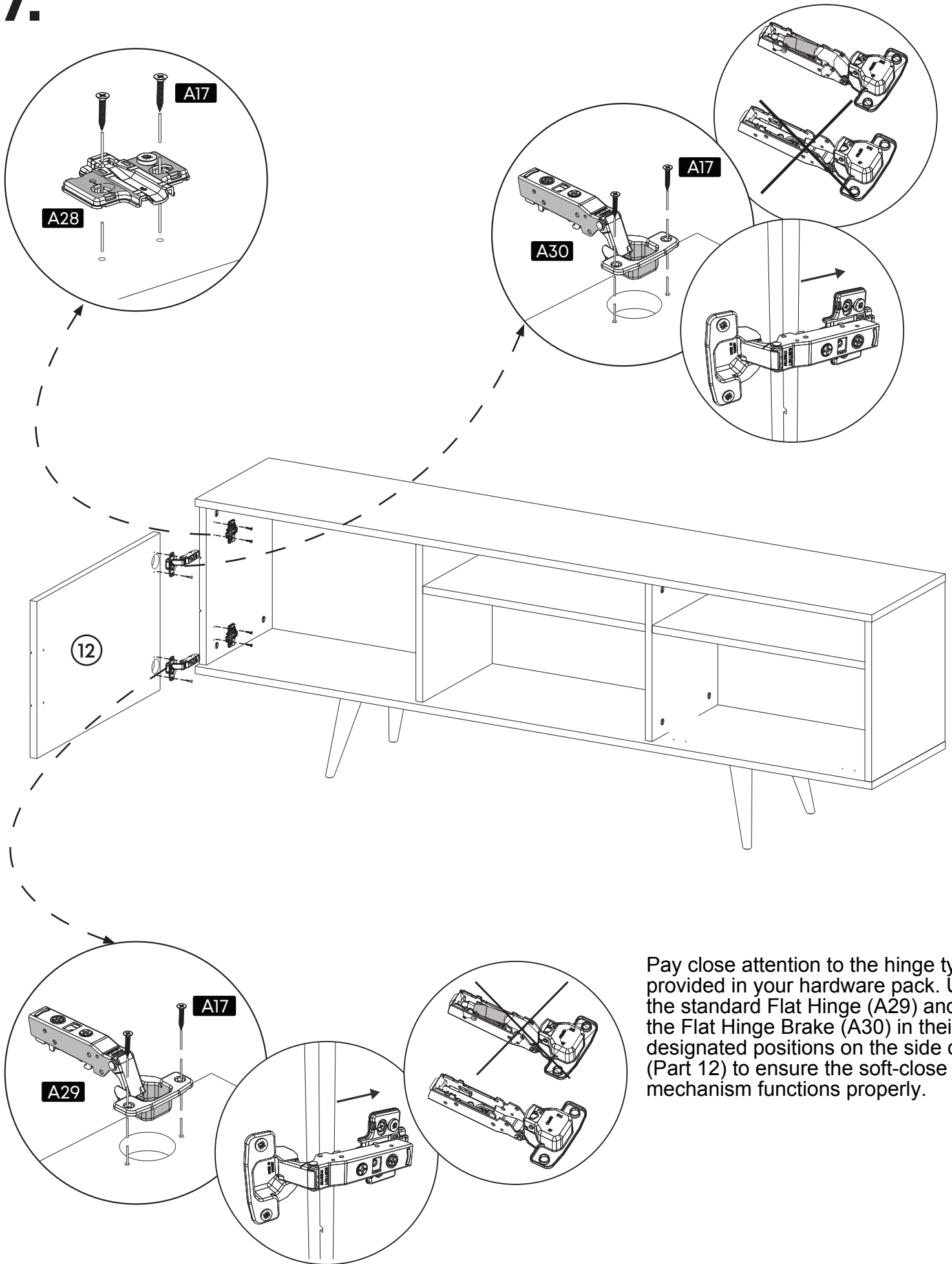

Pay close attention to the hinge types provided in your hardware pack. Use the standard Flat Hinge (A29) and the Flat Hinge Brake (A30) in their designated positions on the side door (Part 12) to ensure the soft-close mechanism functions properly.

8.

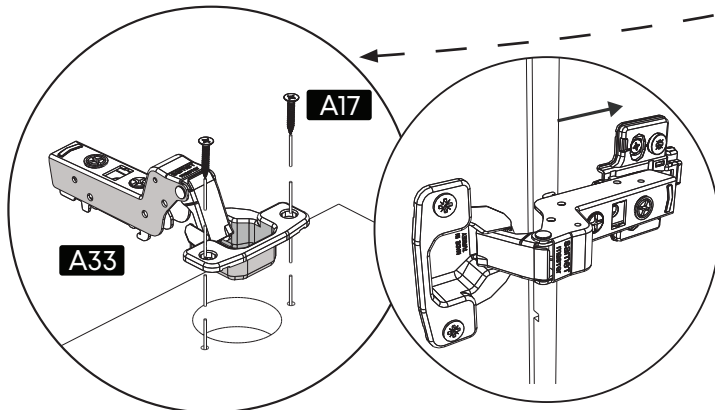
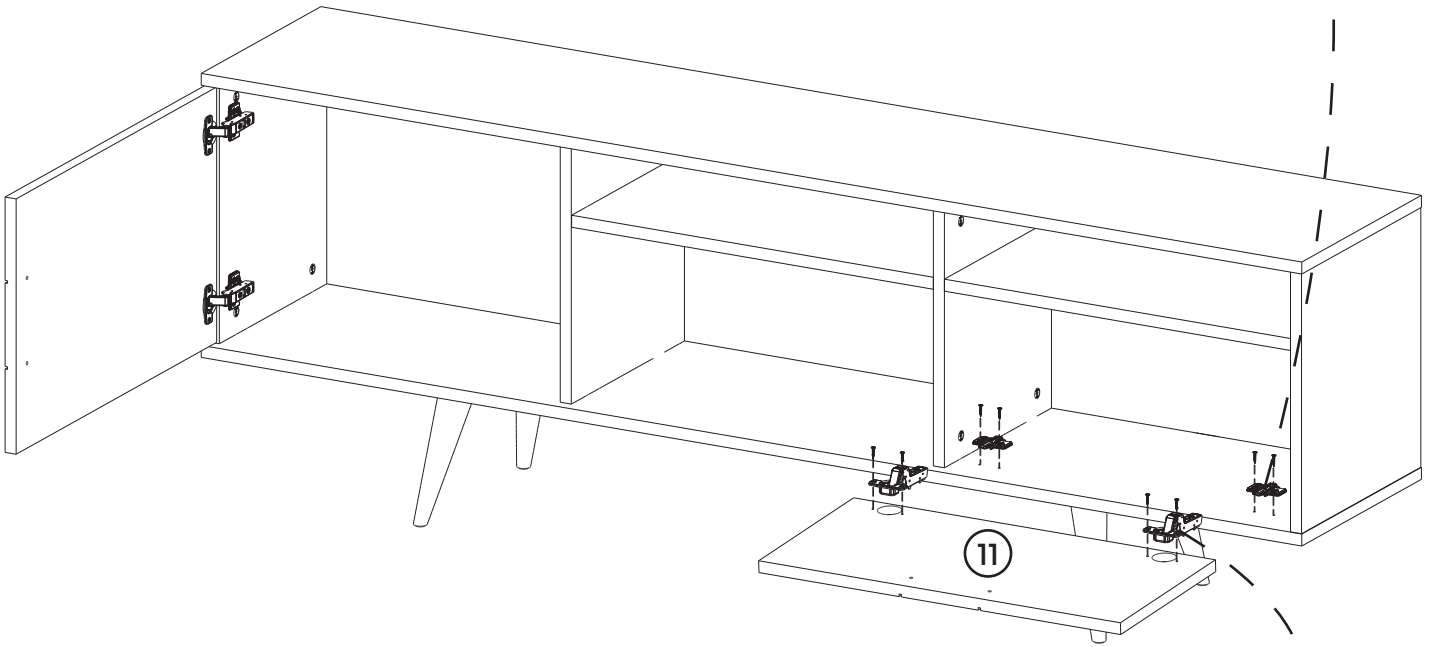
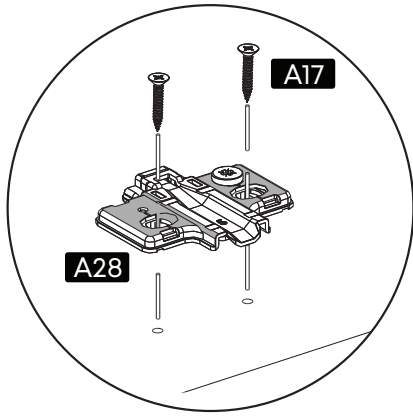

9.

Settings of Hinge

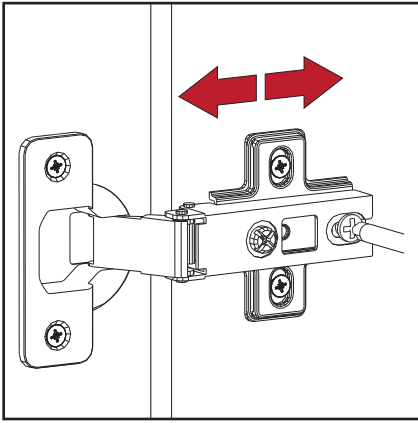

Settings of Hinge

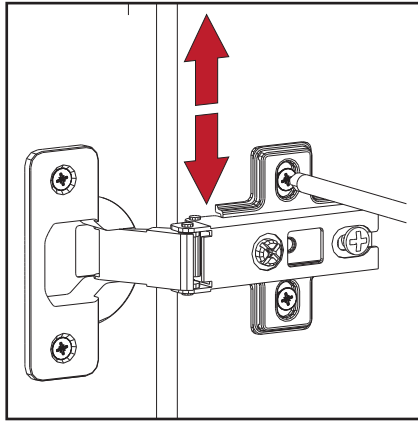

Settings of Hinge

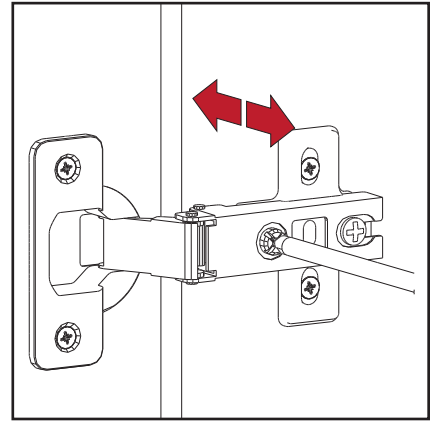

Use the adjustment screws on the hinge bodies to align the door (Part 12) left-to-right and up-and-down. Adjust them until the door sits perfectly level and provides a clean, full overlay directly over the cabinet frame, eliminating any uneven gaps.

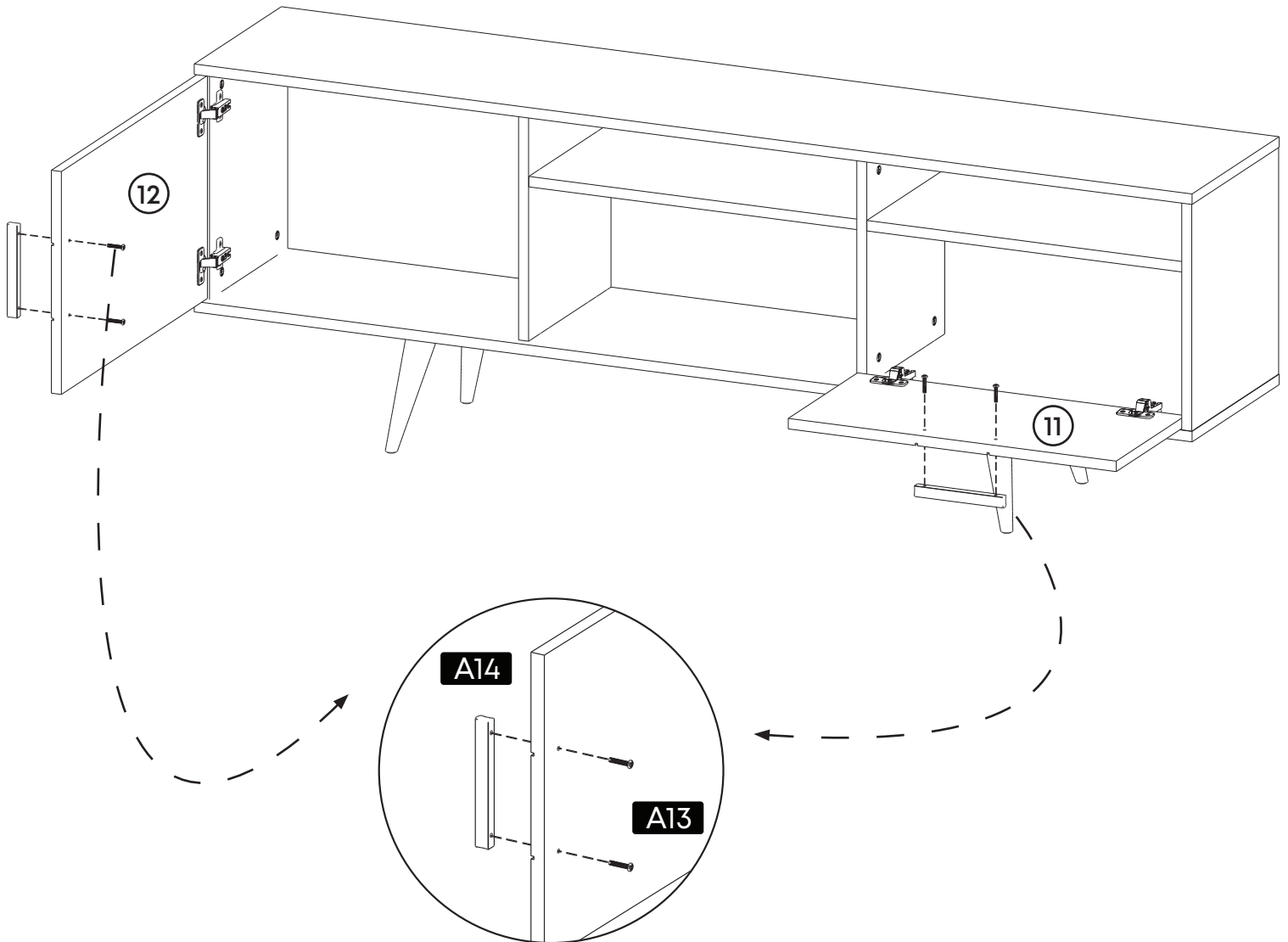

10.

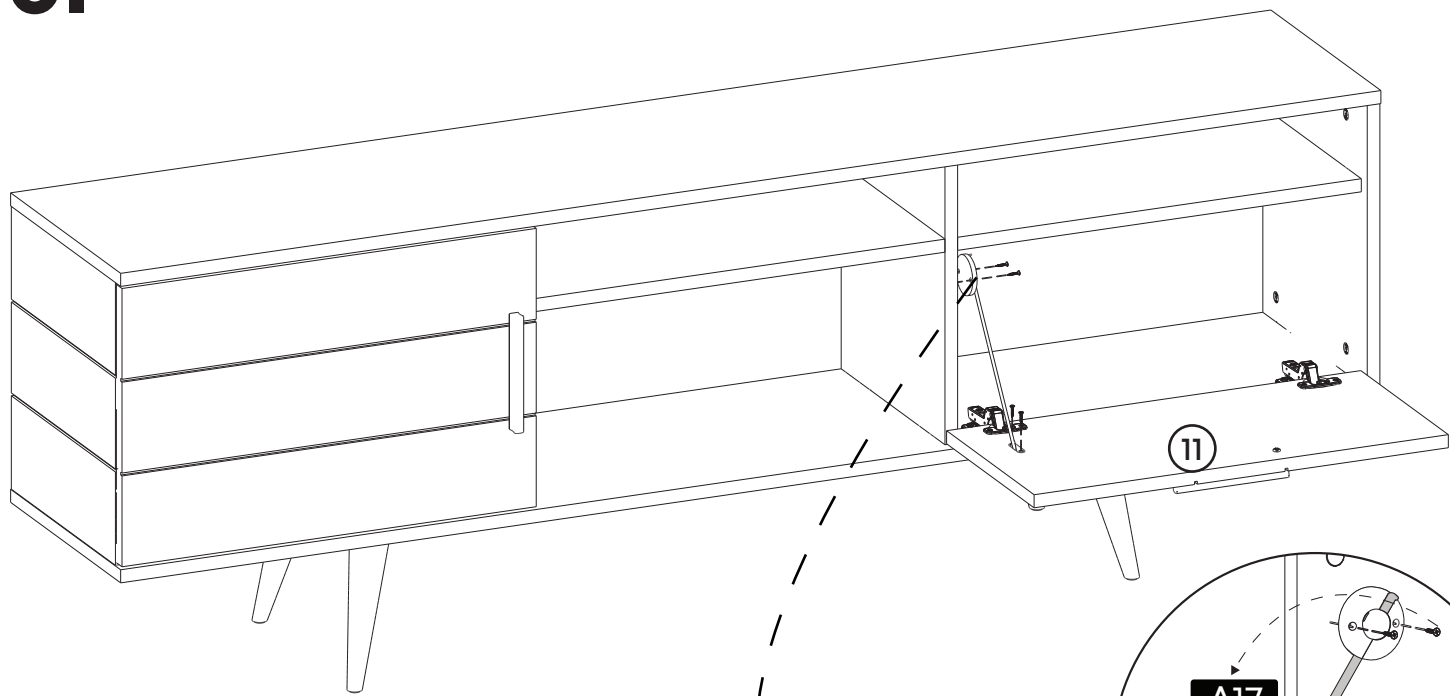

When installing the piston (A16), have a second person hold the drop-down door (Part 11) perfectly level at a 90-degree angle. Securing the piston while the door is fully supported prevents the hinges from over-extending and damaging the wood.

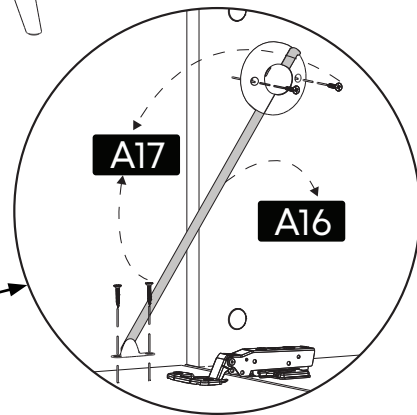

11.

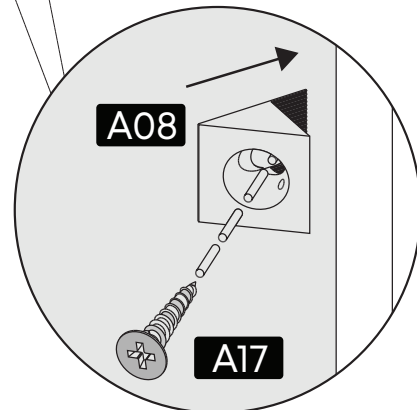
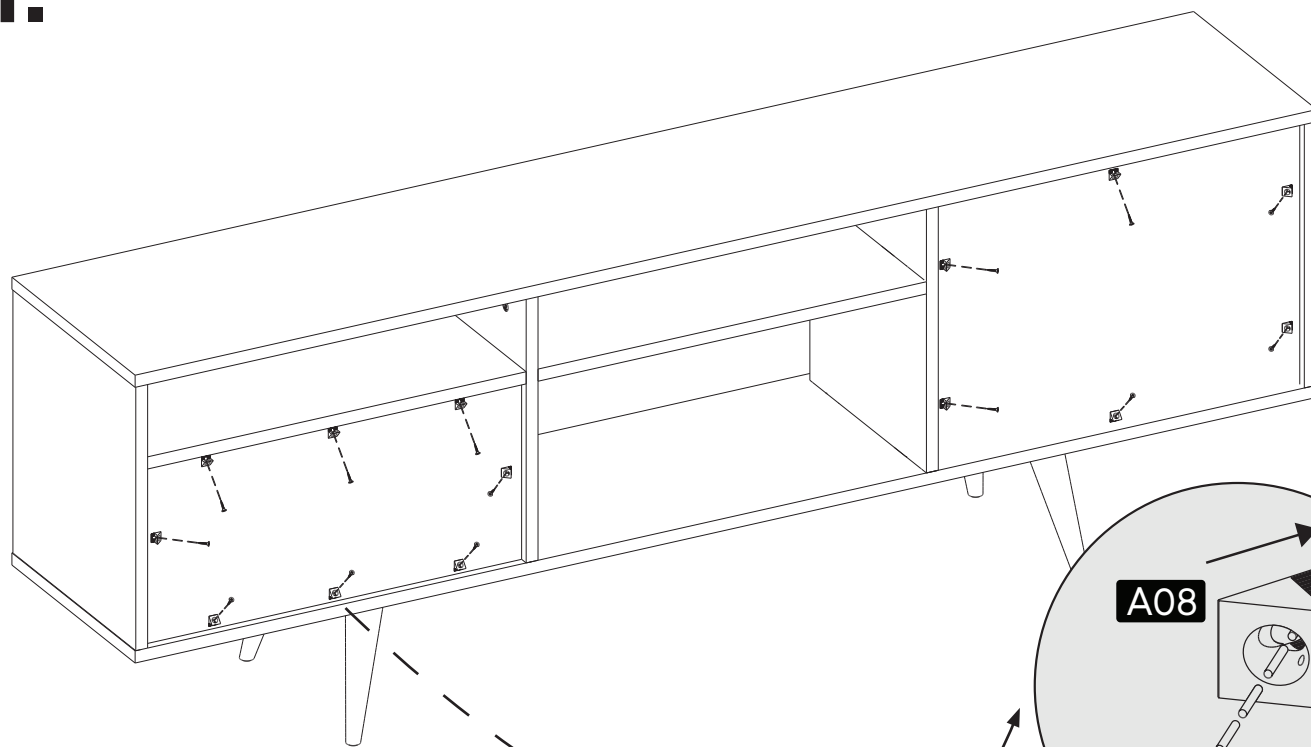

12.

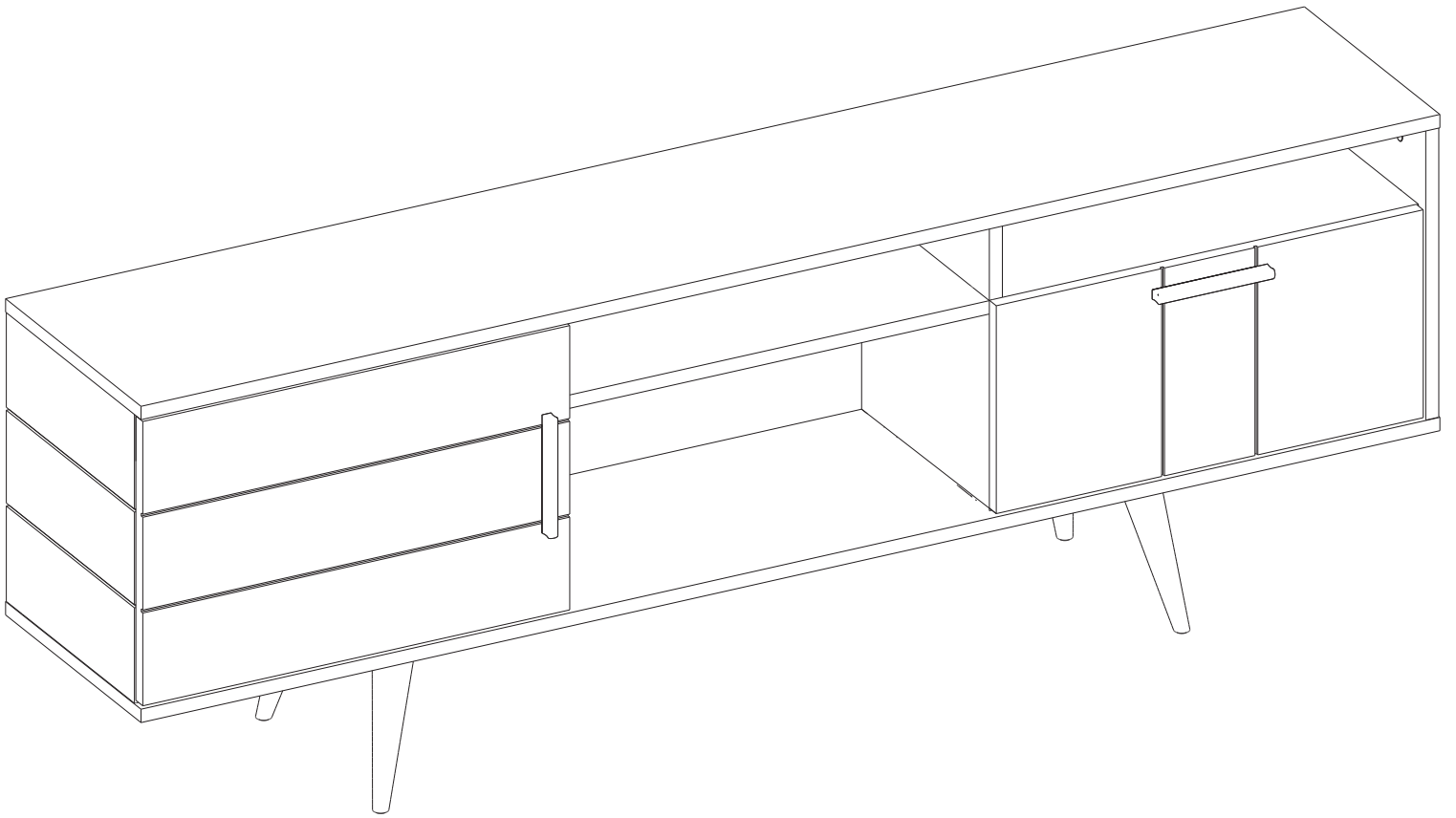
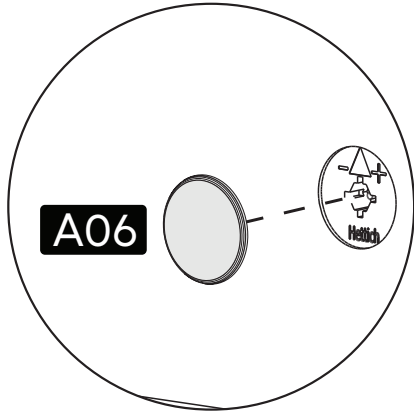

contact us for support

contact@minimadecor.com

+1 (302) 893-9213



www.minimadecor.com.tr

www.minimadecor.us

www.minimadecor.de