

# ASSEMBLY INSTRUCTIONS

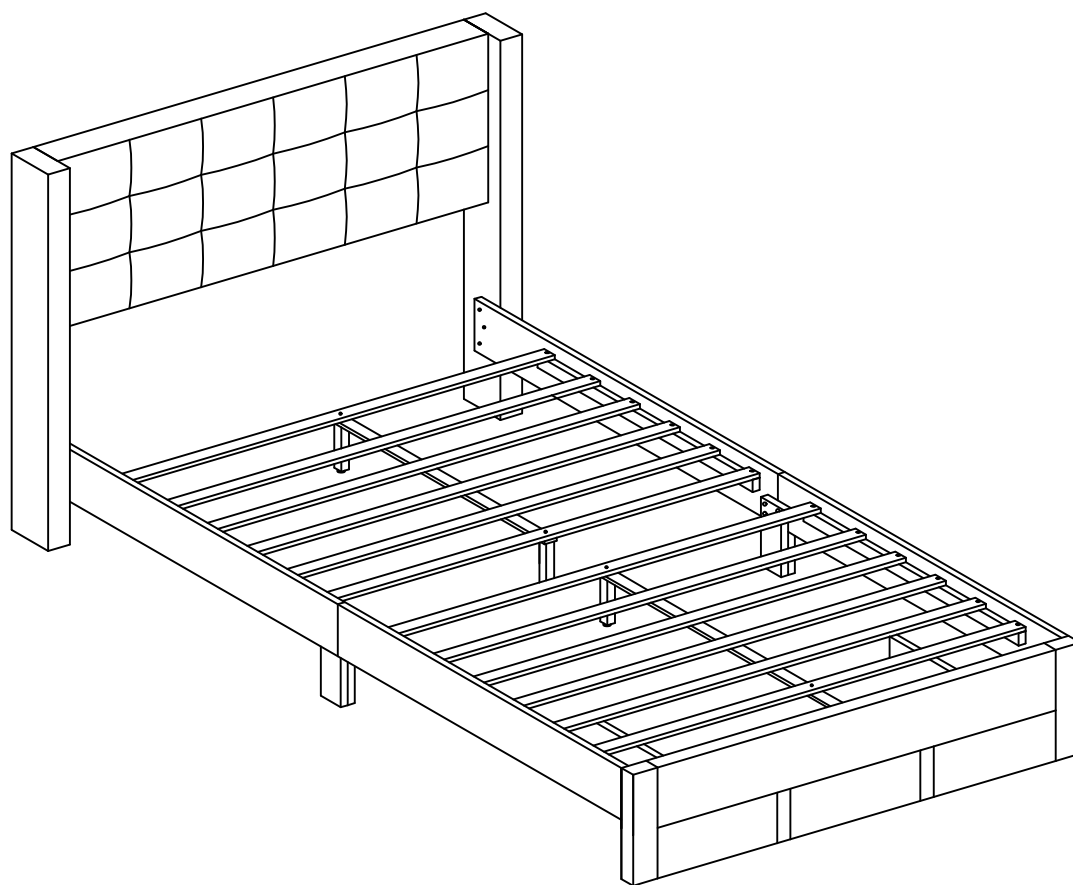

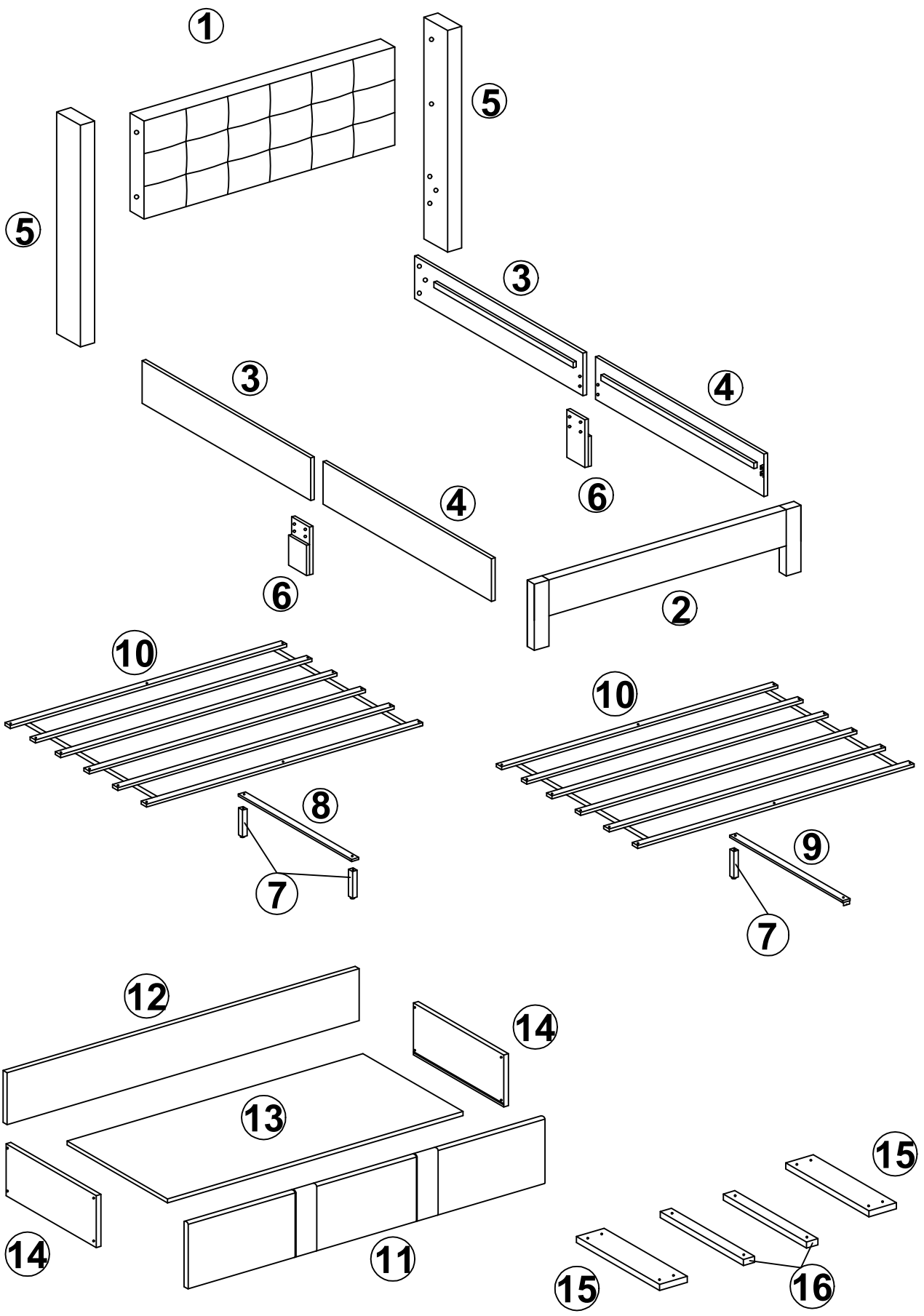





**WF531187**

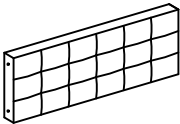
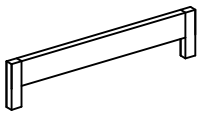
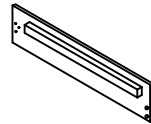
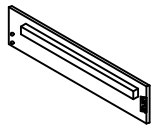

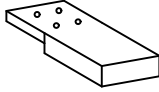

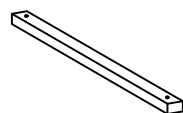
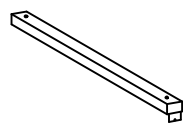
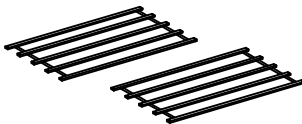

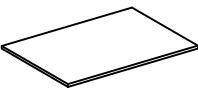
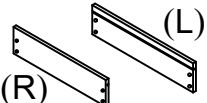
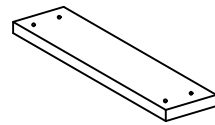
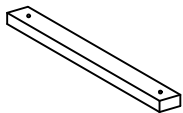

# Detail View

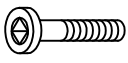
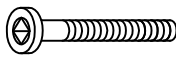
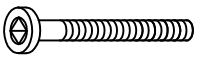
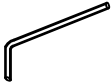
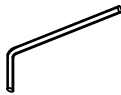



# Part List & Hardware List (WF531187)

<b>1</b>		<b>2</b>		<b>3</b>	
Headboard - 1pc		Footboard - 1pc		Side Rail (L/R) - 2pcs	
<b>4</b>		<b>5</b>		<b>6</b>	
Side Rail (L/R) - 2pcs		Side Wing (L/R) - 2pcs		Side Rail Support Leg - 2pcs	
<b>7</b>		<b>8</b>		<b>9</b>	
Support Leg - 3pcs		Center Rail - 1pc		Center Rail - 1pc	
<b>10</b>		<b>11</b>		<b>12</b>	
Slat 6 roll - 2pcs		Footboard Front Panel - 1pc		Footboard Back Panel - 1pc	
<b>13</b>		<b>14</b>		<b>15</b>	
Footboard Bottom Panel - 1pc		Drawer Side Panel (L/R) - 2pcs		Bottom Panel Big Support Wood - 2pcs	
<b>16</b>					
Bottom Panel Small Support Wood - 2pcs					

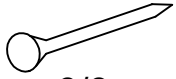
# Hardware List (WF531187)

<b>A</b>  Ø1/4"*20mm Hex-Head bolt (4pcs)	<b>B</b>  Ø1/8"*30mm Hex-Head bolt (8pcs)	<b>C</b>  Ø1/8"*50mm Hex-Head bolt (10pcs)
<b>D</b>  Ø1/8"*60mm Hex-Head bolt (3pcs)	<b>E</b>  65mm Allen key (1pc)	<b>F</b>  70mm Allen key (1pc)
<b>G</b>  #3.5*16mm Screw (16pcs)	<b>H</b>  #4*25mm Screw (1pc)	<b>I</b>  #4*32mm Screw (36pcs)
<b>J</b>  #4*50mm Screw (8pcs)	<b>K</b>  M6 Spring Washer (10pcs)	<b>L</b>  M6 Flat Washer (18pcs)
<b>M</b>  Roller (4pcs)	<b>N</b>  6/8 Power Nail (24pcs)	

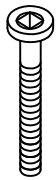
# Step 1:

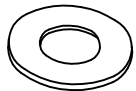
<b>C</b>		<b>K</b>	
<b>4pcs</b>		<b>4pcs</b>	
		<b>L</b>	
		<b>4pcs</b>	

Back view

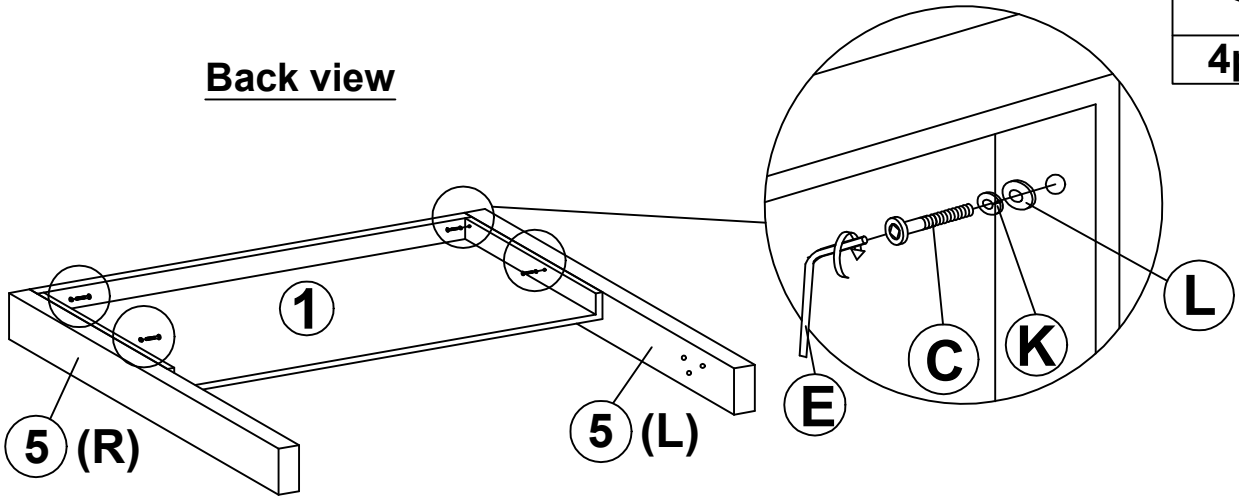

# Step 2:

<b>A</b>	
<b>4pcs</b>	

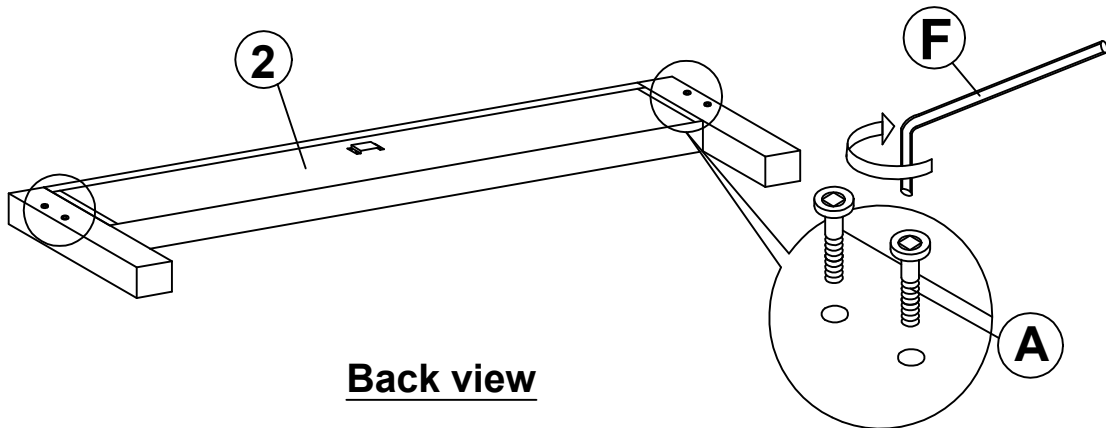

Back view

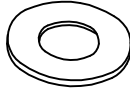
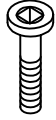

# Step 3:

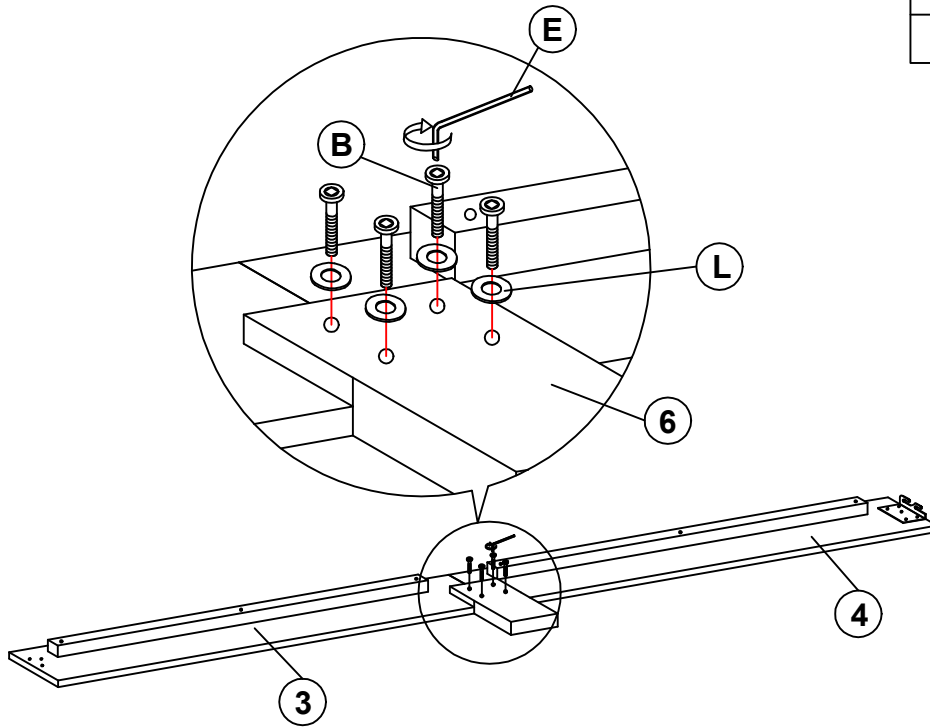
<b>L</b>	<b>B</b>
	
8pcs	8pcs

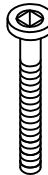

**x2**

# Step 4:

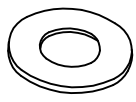
<b>C</b>	<b>K</b>
	
6pcs	6pcs
	<b>L</b>
	
	6pcs

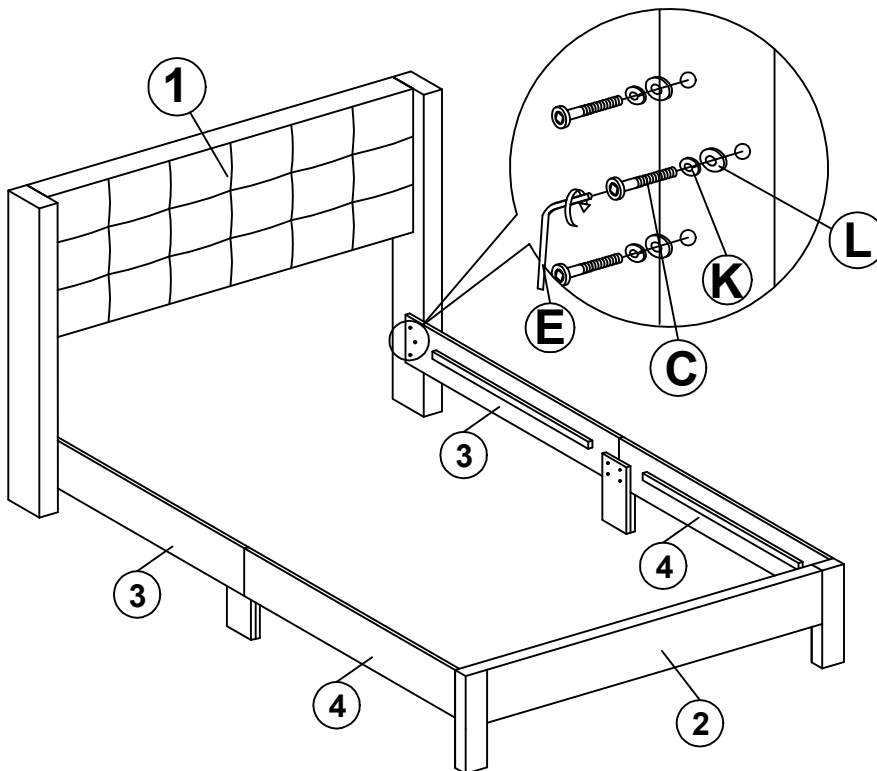

# Step 5:

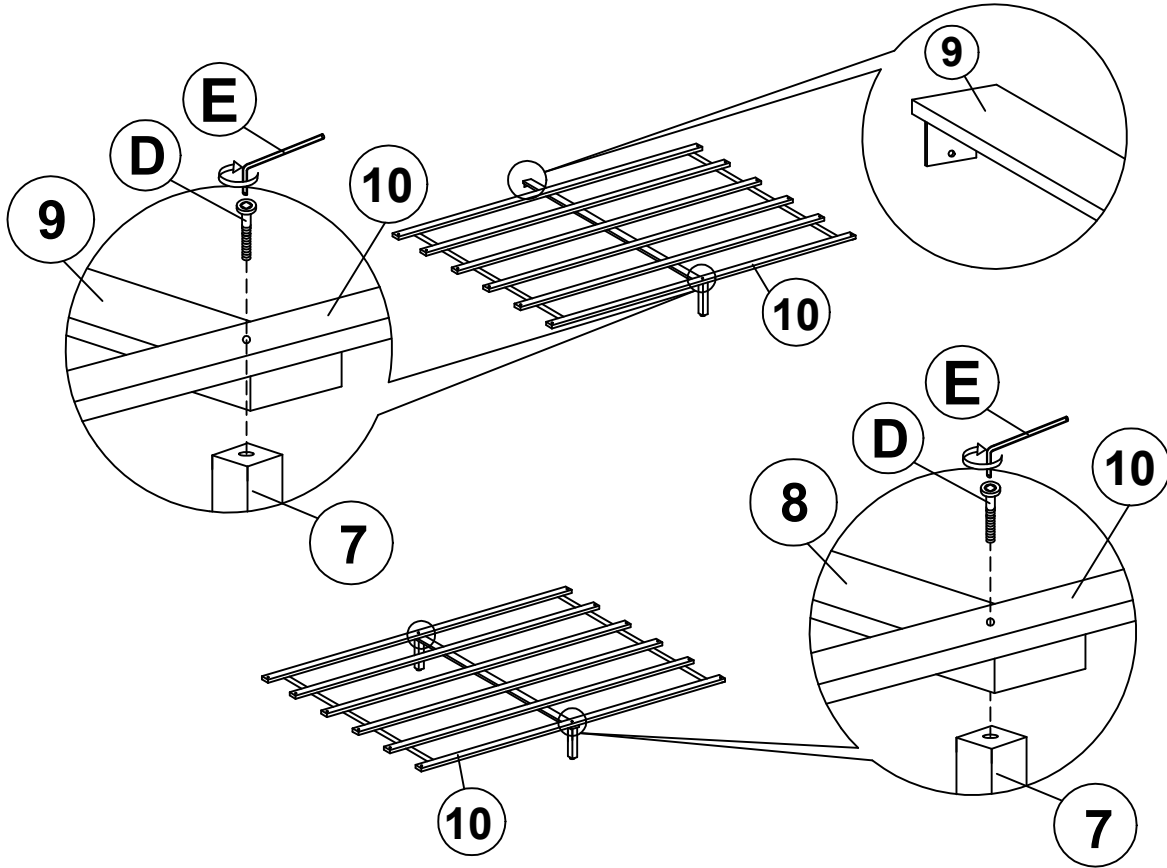
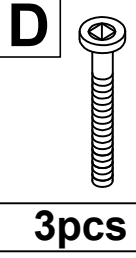

# Step 6:

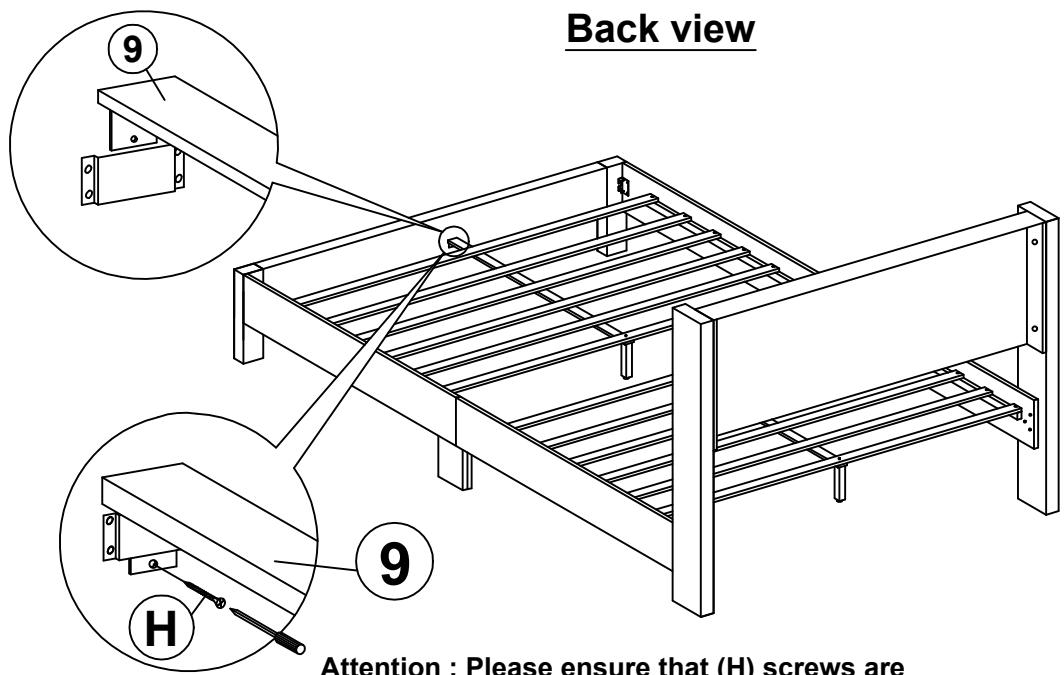
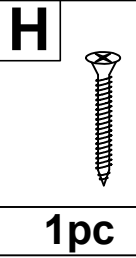

Attention : Please ensure that (H) screws are fixed as shown to ensure stability of bed.

# Step 7:

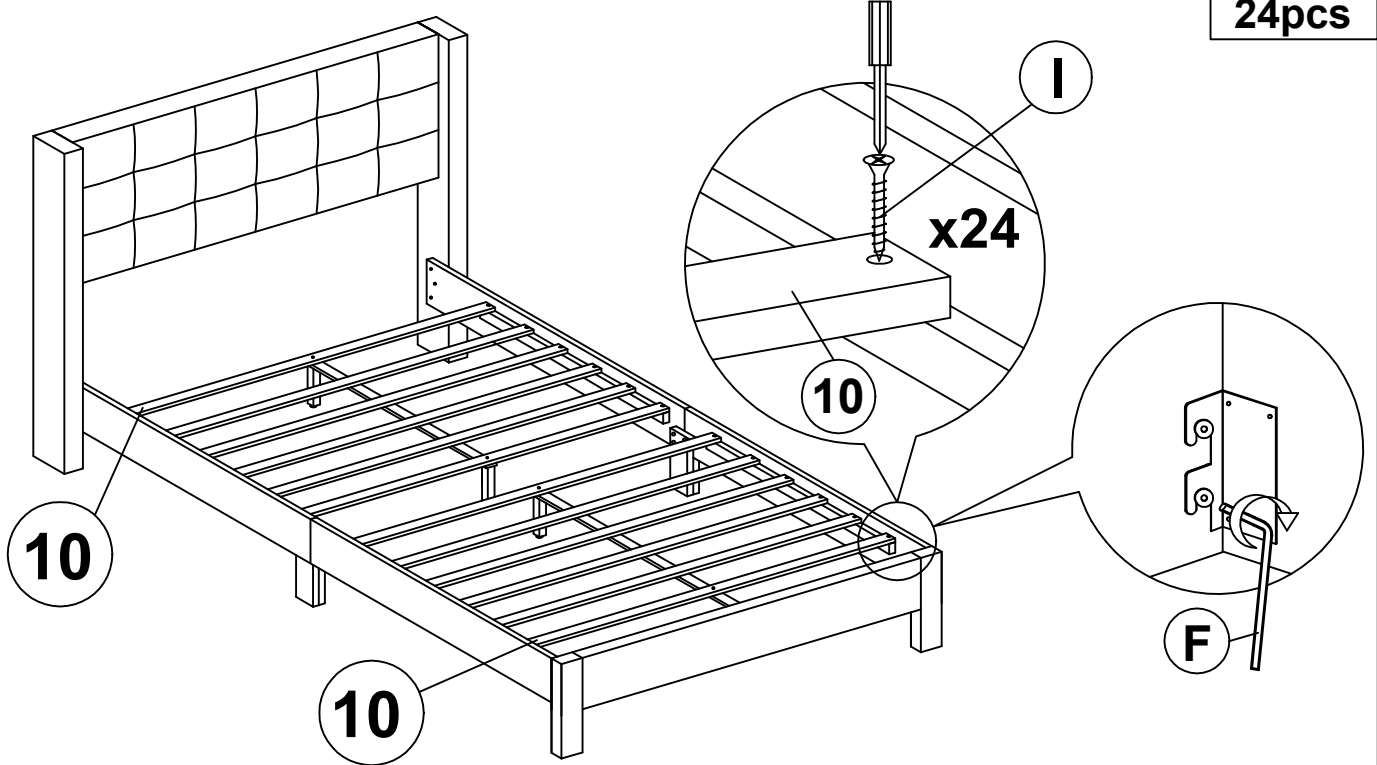
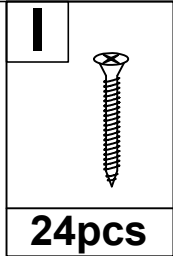

# Step 8:

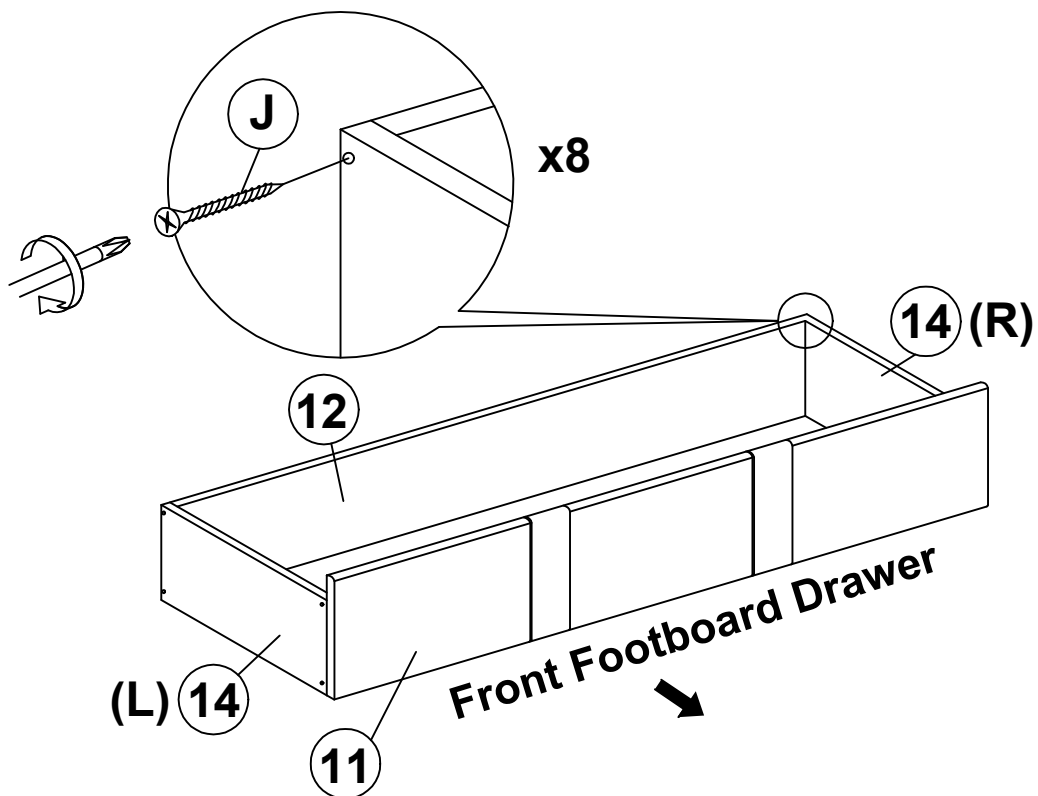
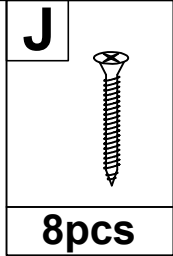

# Step 9:

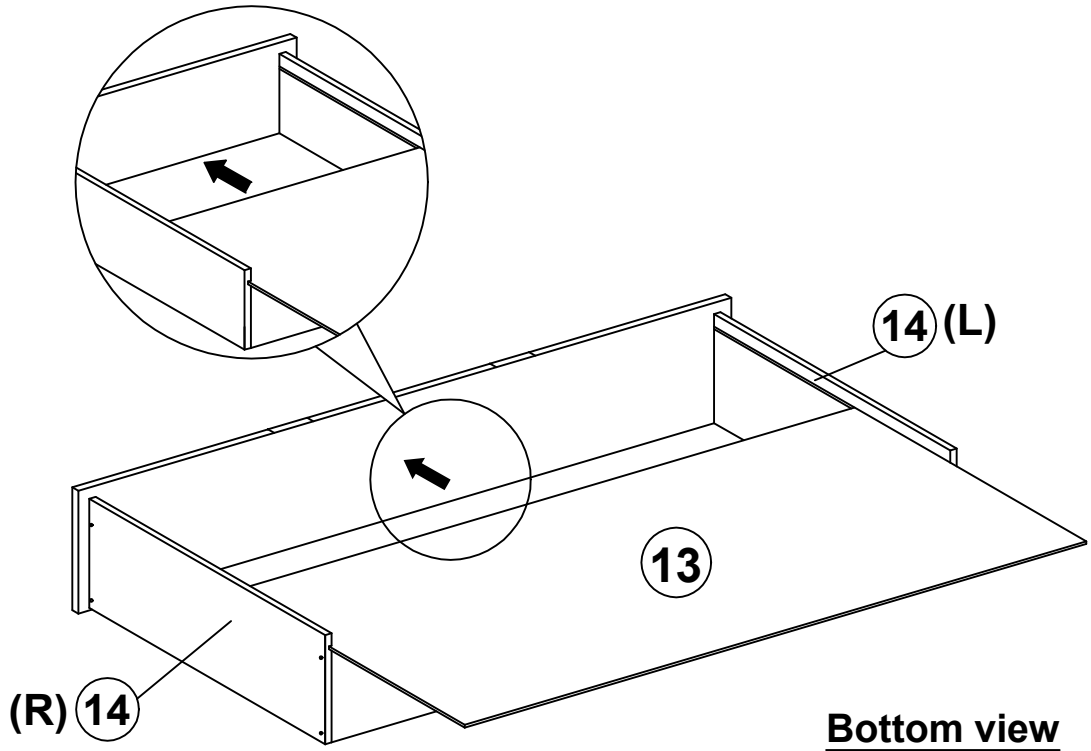

# Step 10:

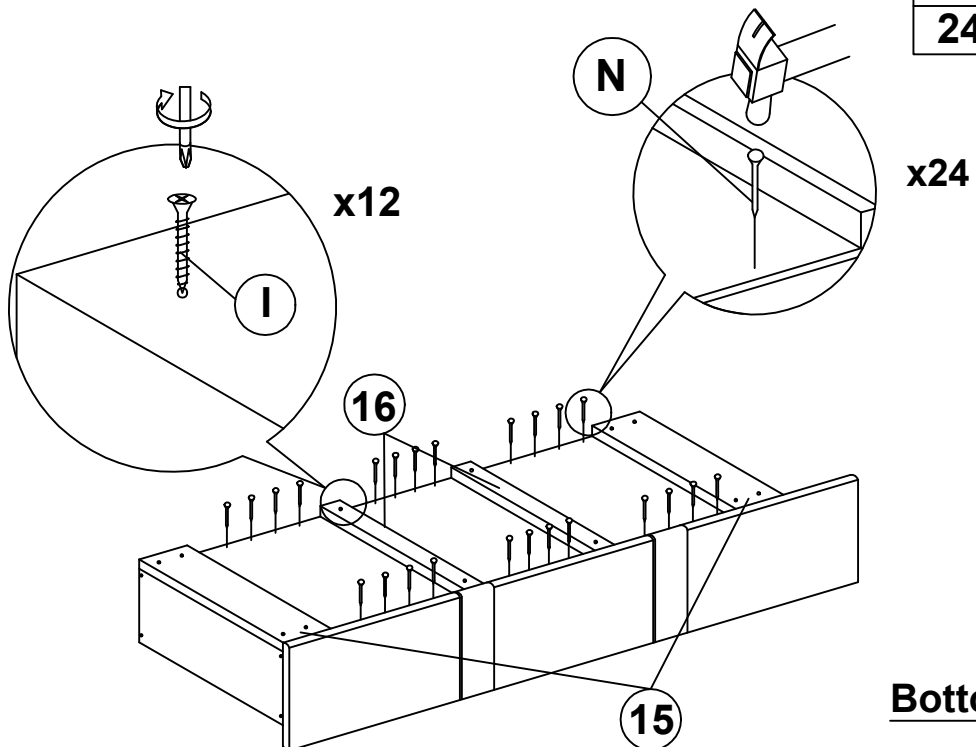

# Step 11:

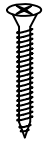
<b>M</b>	<b>G</b>
	
<b>4pcs</b>	<b>16pcs</b>

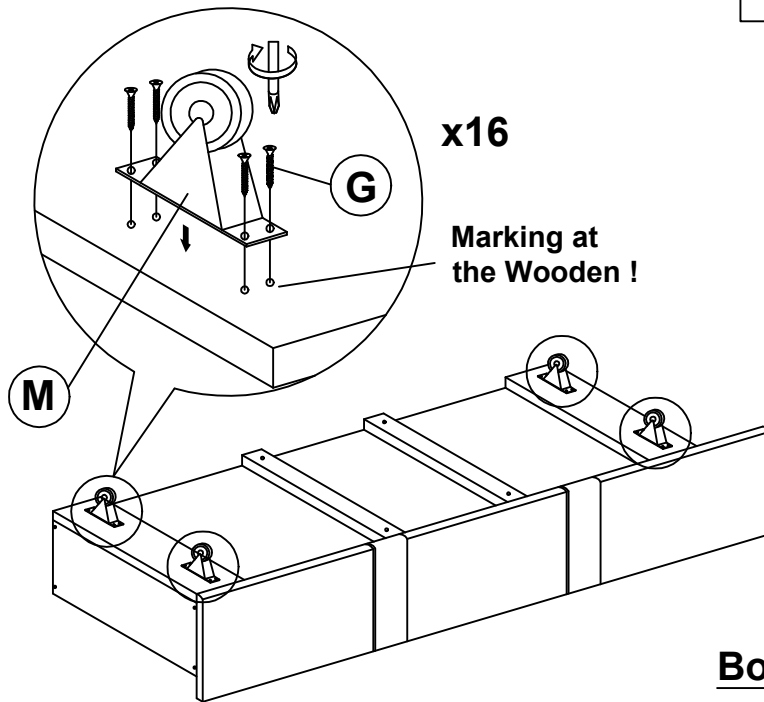

# Step 12:

