

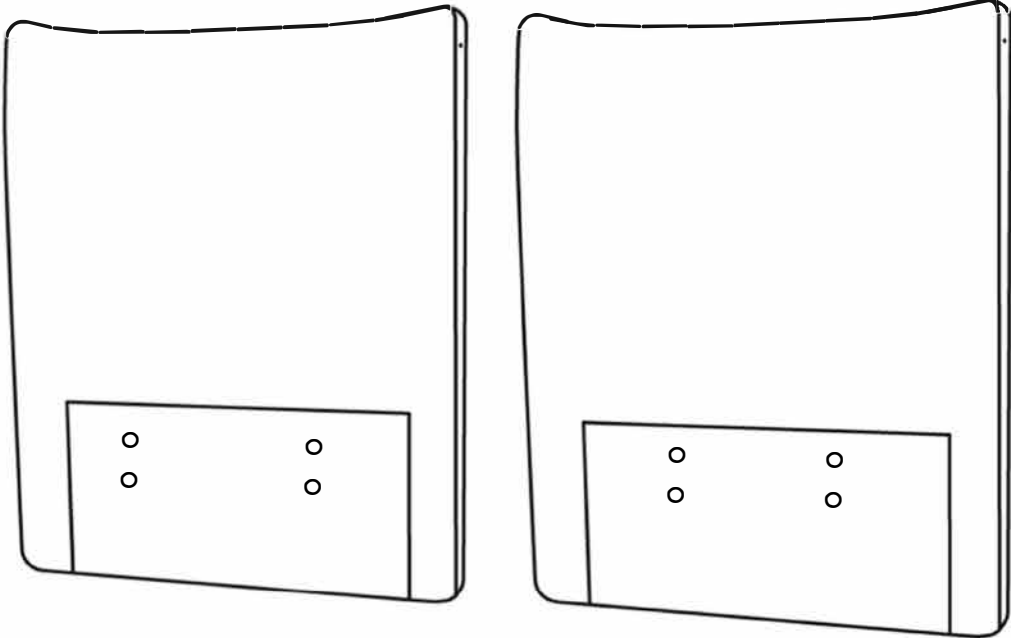

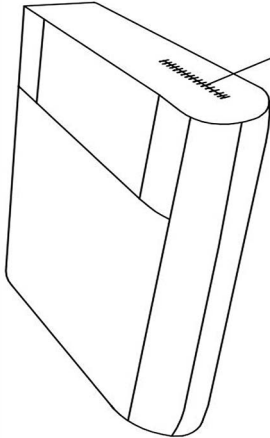



# 2pcs Armrest/ Backrest Module



## Parts List (Checking the part lists when you get the packing)



x 2

	Ax1
	Bx4
	Cx1
	Dx2
	Ex2



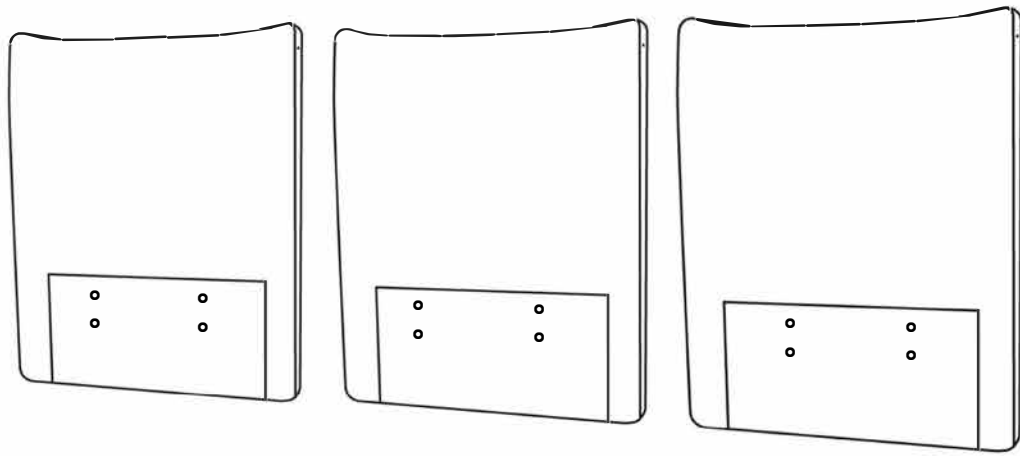

## 3pcs Armrest/ Backrest Module

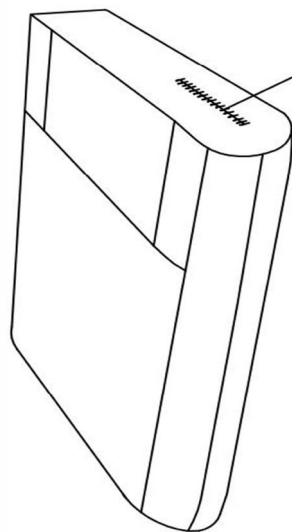

### Parts List (Checking the part lists when you get the packing)



x 3

	Ax1
	Bx4
	Cx1
	Dx2
	Ex2

## Installation

**Step 1: Locate the zippered pocket at the bottom of the armrest/ backrest and take the hardware out.**

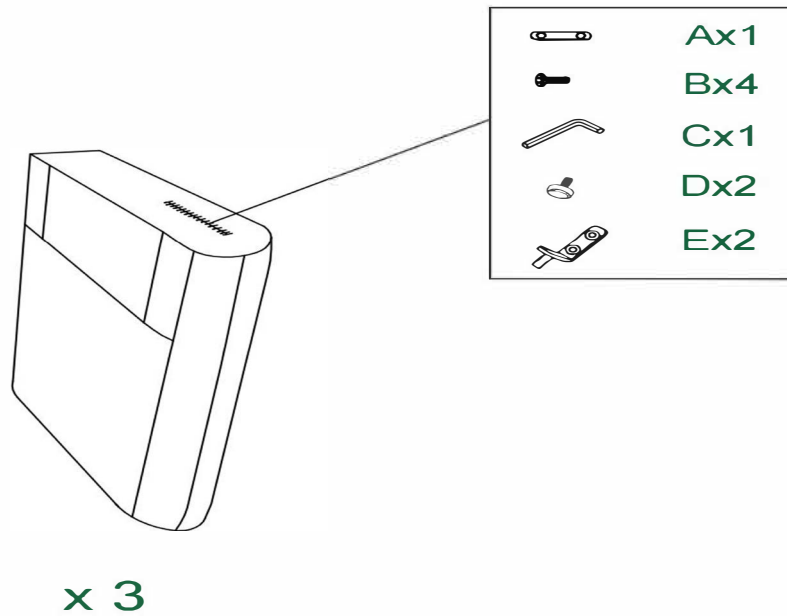

**Step 2: Assemble the screw into the armrest hole.**

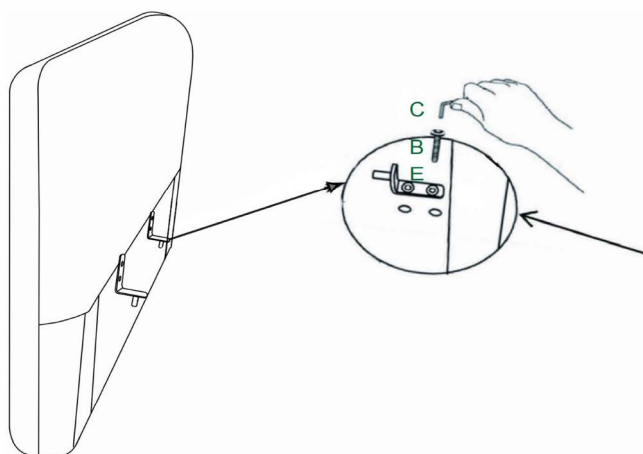

# Seat Module

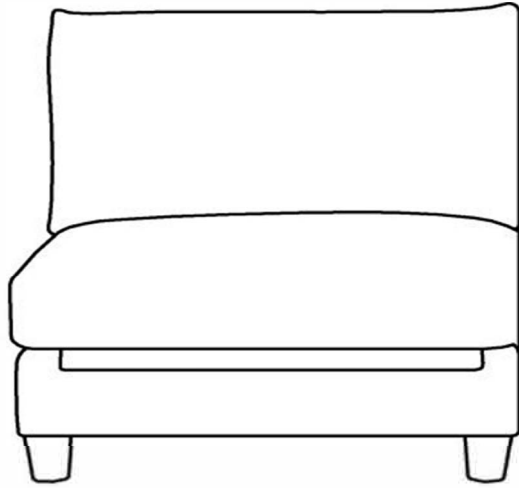

## Open the package and check contents:

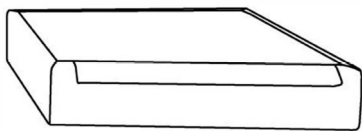

Ax1



Bx1



Cx1



Dx4



Ex1



Fx1



Gx2

# Installation

Step 1: Use the included tool F to unscrew the iron bar.

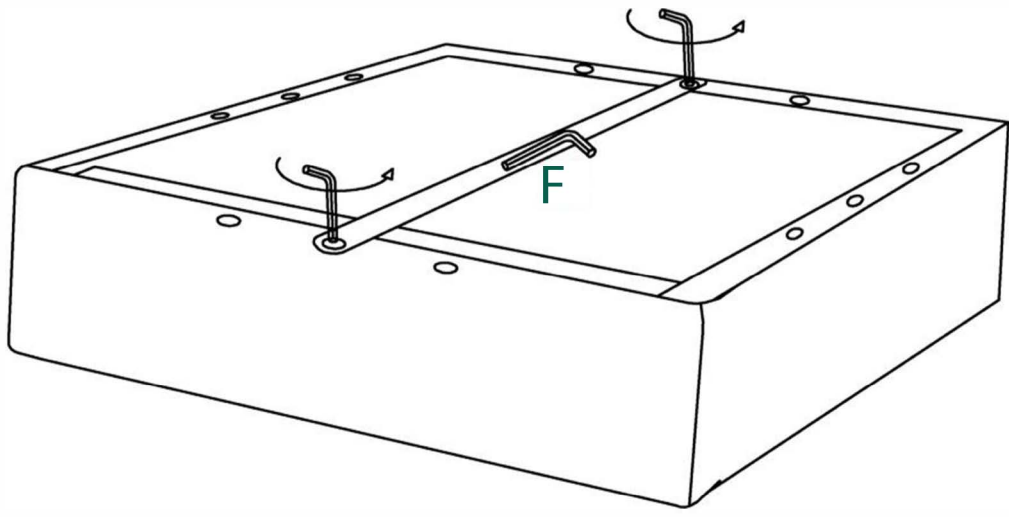

Step 2: Open the seat's storage lid to access the followings.

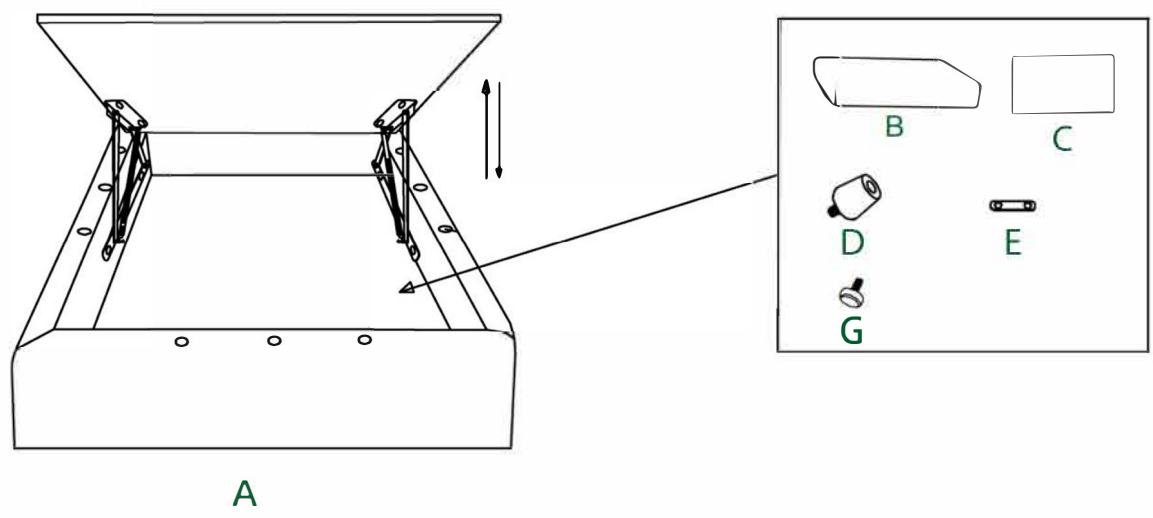

### Step 3: Install sofa legs.

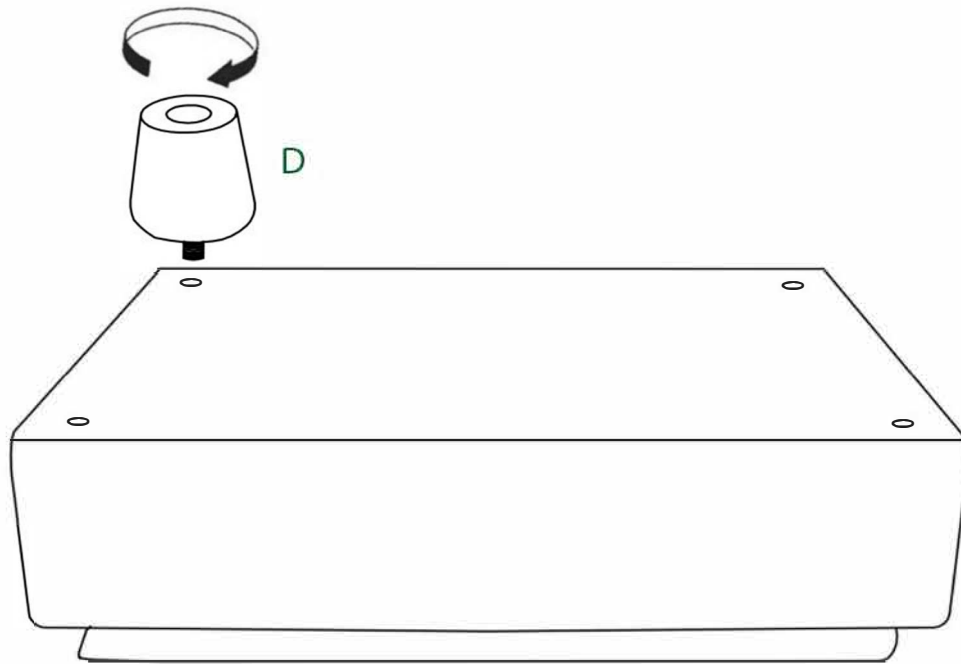

### Step 4: Unwrap the compressed cushion and place it onto the footrest.

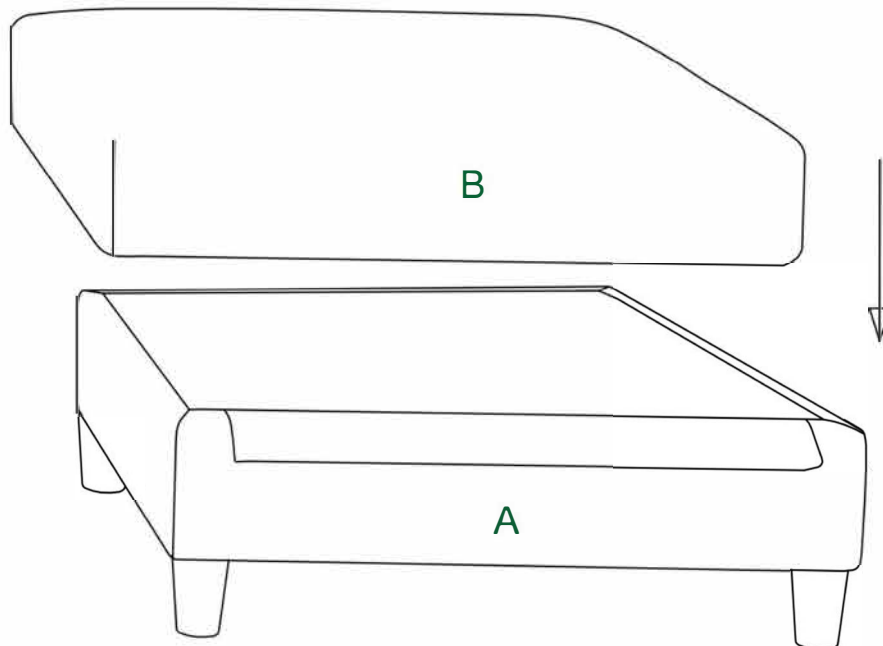

**Step 5: Insert the assembly armrest and backrest into the pre-drilled holes on the seat.**

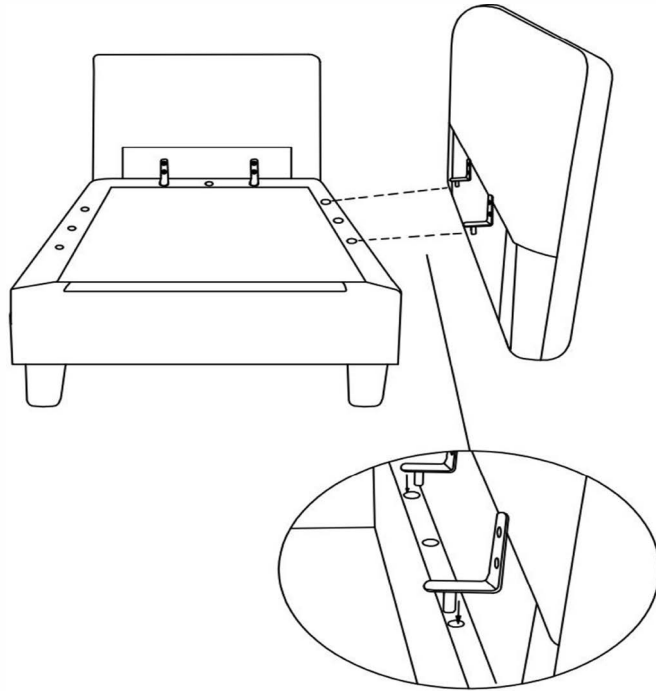

**Step 6: Use Connector E + Screw G to fasten from the underside of the sofa.**

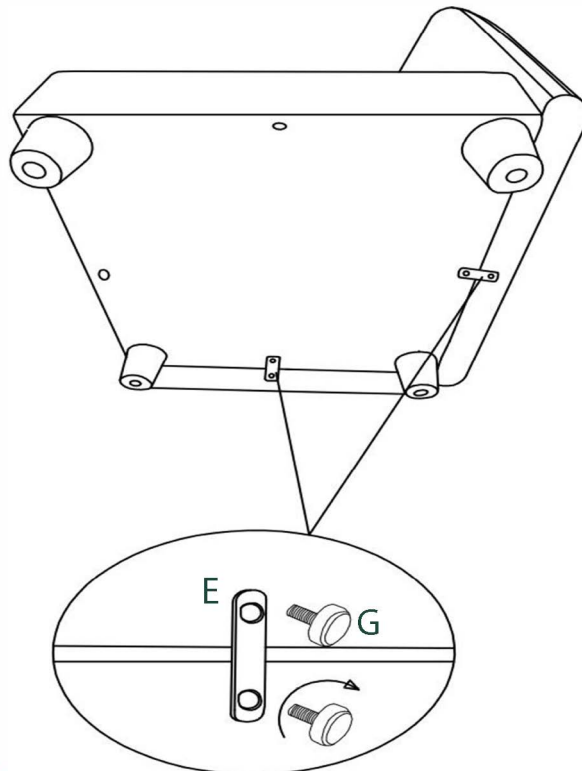

---

**Step 7: Use Connector E+ Screw G to link seats side-by-side.**

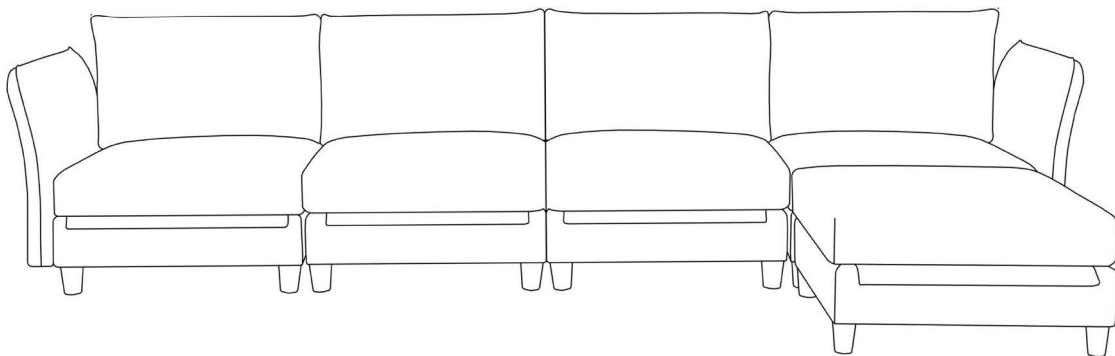
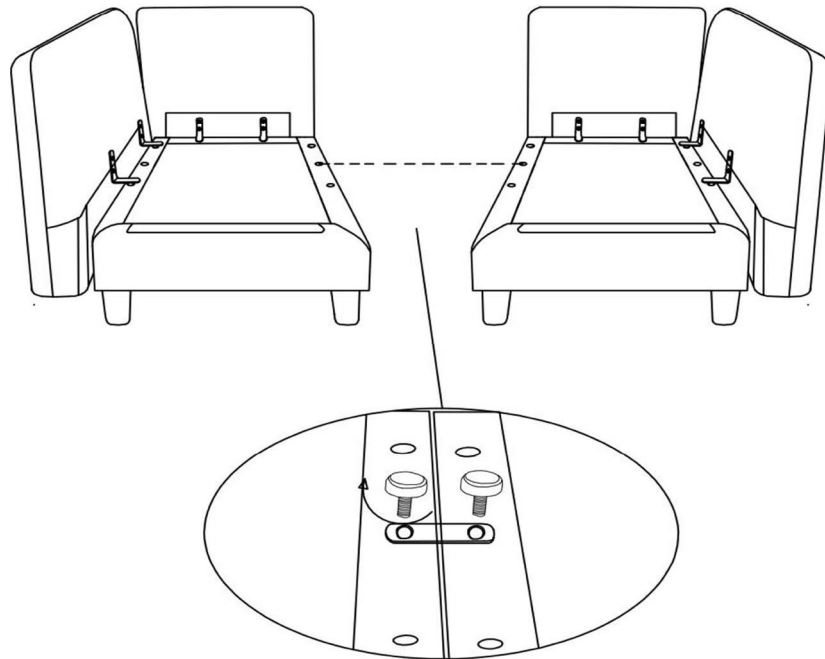

**Enjoy your modular sofa!**

## After sales notification

- \*Please retain these instructions for future reference.
- \*Please read the instruction sheets completely before assembly.
- \*Assemble the sofa on a protected surface to avoid scratching the components of sofa.
- \*Be careful not to cross -thread screws.
- \*Do not use power tools.
- \*According to the fabric characteristics of sofa, please avoid direct-sun exposure.
- \*If the sofa is smelling, please try to air it for 24-48 hours and the smell will go away.Sometimes it's because it was packed for a long time,so It's very normal to get thatsmell.

## Return /Damage policy

- \*Please be sure to return the original package, otherwise, it will not be accepted by the warehouse.
- \*Take a photo of the box tracking number to helps us identify your product number to ensure you receive the correct parts.
- \*Take a photo of Damage (if applicable box or products) for you can get a replacement or refund quickly.
- \*Send us an email with the images requested and a description of your claim.