

**DINING TABLE - 66 X 40 INCH**

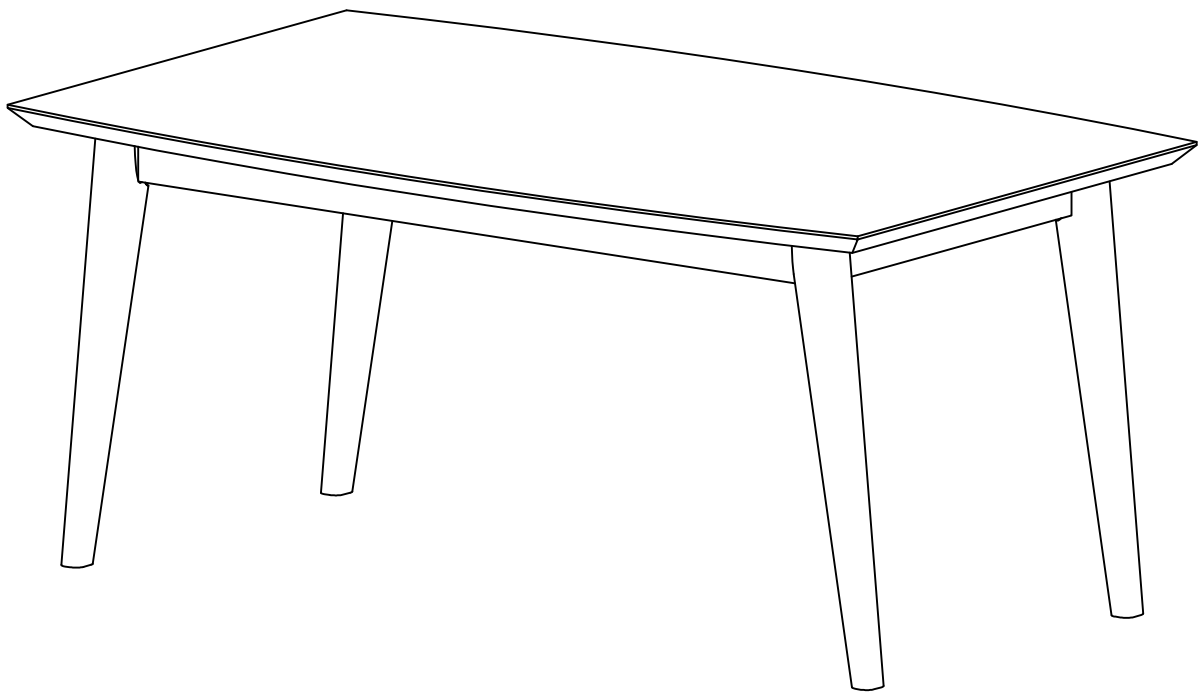

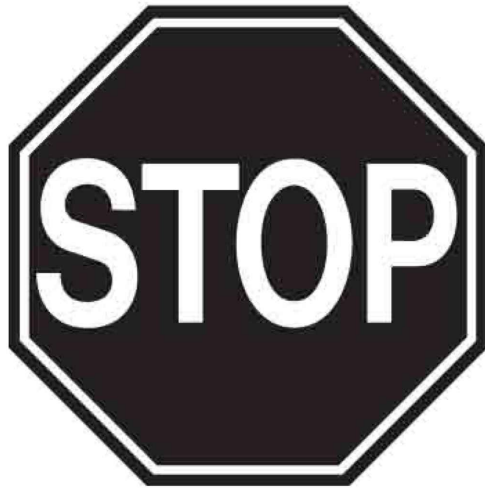

**FOR REPLACEMENT PARTS OR HELP WITH  
ASSEMBLY PLEASE CONTACT US**

**PLEASE ENSURE TO HAVE THE MODEL #  
FROM THE PACKAGING OR INSTRUCTION BOOKLET**

**TO RETURN THE PRODUCT:  
PLEASE CONTACT THE RETAILER  
WHERE THE ITEM WAS PURCHASED FROM**

**ENTER  
TO WIN**

**Upload an image of our furniture  
in your home with a short review  
to our facebook page for a chance to**

**Win up to \$3000**

**IMPORTANT :** Please read this manual carefully before beginning assembly of this product. Keep this manual for future reference.

## SAFETY INFORMATION

Identify all the parts and hardware. Do not discard of the packaging until you have checked that you have all of the parts and hardware required. Hardware package may have spare parts.

**WARNING:** This item contains small parts which can be swallowed by children and pets. Keep children and pets away during assembly. To avoid danger of suffocation, always keep plastic bags away from children and pets. We recommend that you assemble this unit on a carpeted floor to avoid scratches. If using power tools, set the tool to low torque to avoid damage.

**May require 2 people for ease of assembly.**

## CARE and MAINTENANCE

To clean, use a soft or slightly damp cloth, then wipe with a clean, dry cloth. Dust with soft dry cloth.

Do not use ammonia-based cleaning products, as they will damage the finish. Do not leave liquids or damp cloths on this furniture.

To avoid dulling of the finish, do not place furniture in direct sunlight.

Please inspect and tighten all screws or bolts on a regular basis to ensure proper performance and safety of your item.

# PRE-ASSEMBLY INFORMATION

## PART DESCRIPTION

A

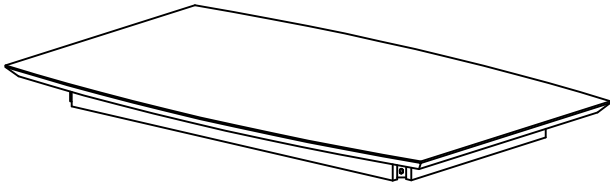

TOP  
QTY 1

B

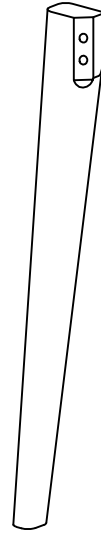

LEG  
QTY 4

**NEED HELP?** For help with assembly or if you are missing a part,  
Please call customer service

## PRE-ASSEMBLY INFORMATION

### HARDWARE DESCRIPTION

1

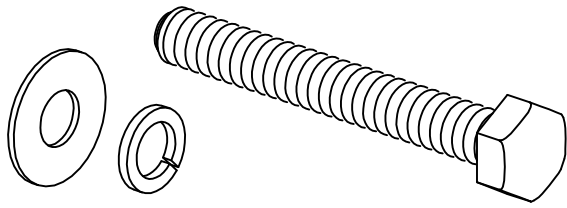

BOLT  
M8 X 60mm  
QTY 8 SETS

2

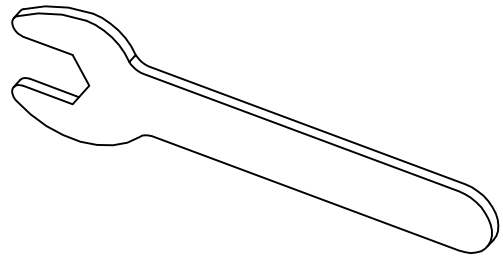

SPANNER  
QTY 1

**NEED HELP?** For help with assembly or if you are missing a part,  
Please call customer service

# PRE-ASSEMBLY INFORMATION

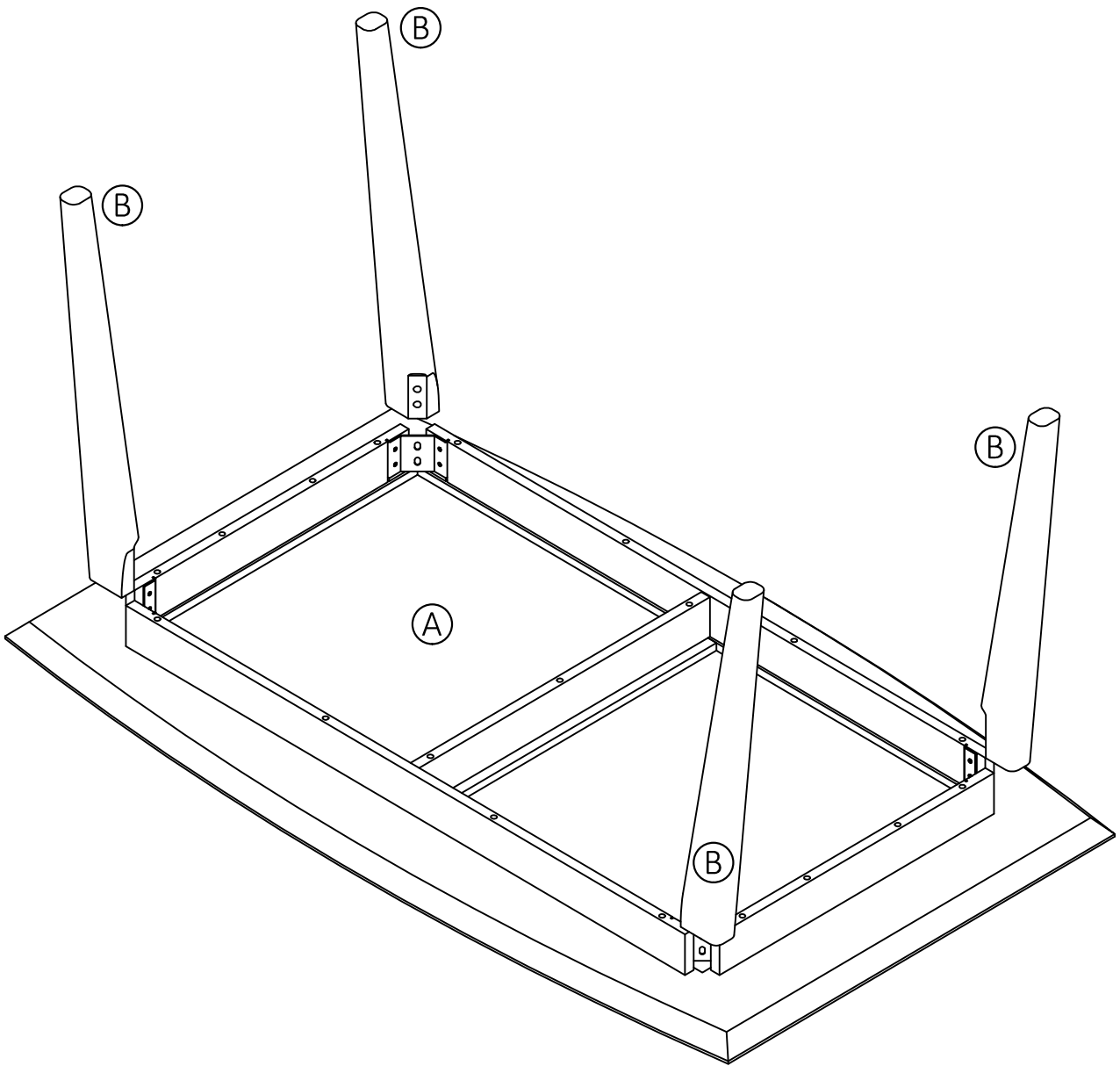

## PRE-ASSEMBLY INFORMATION

### STEP-1

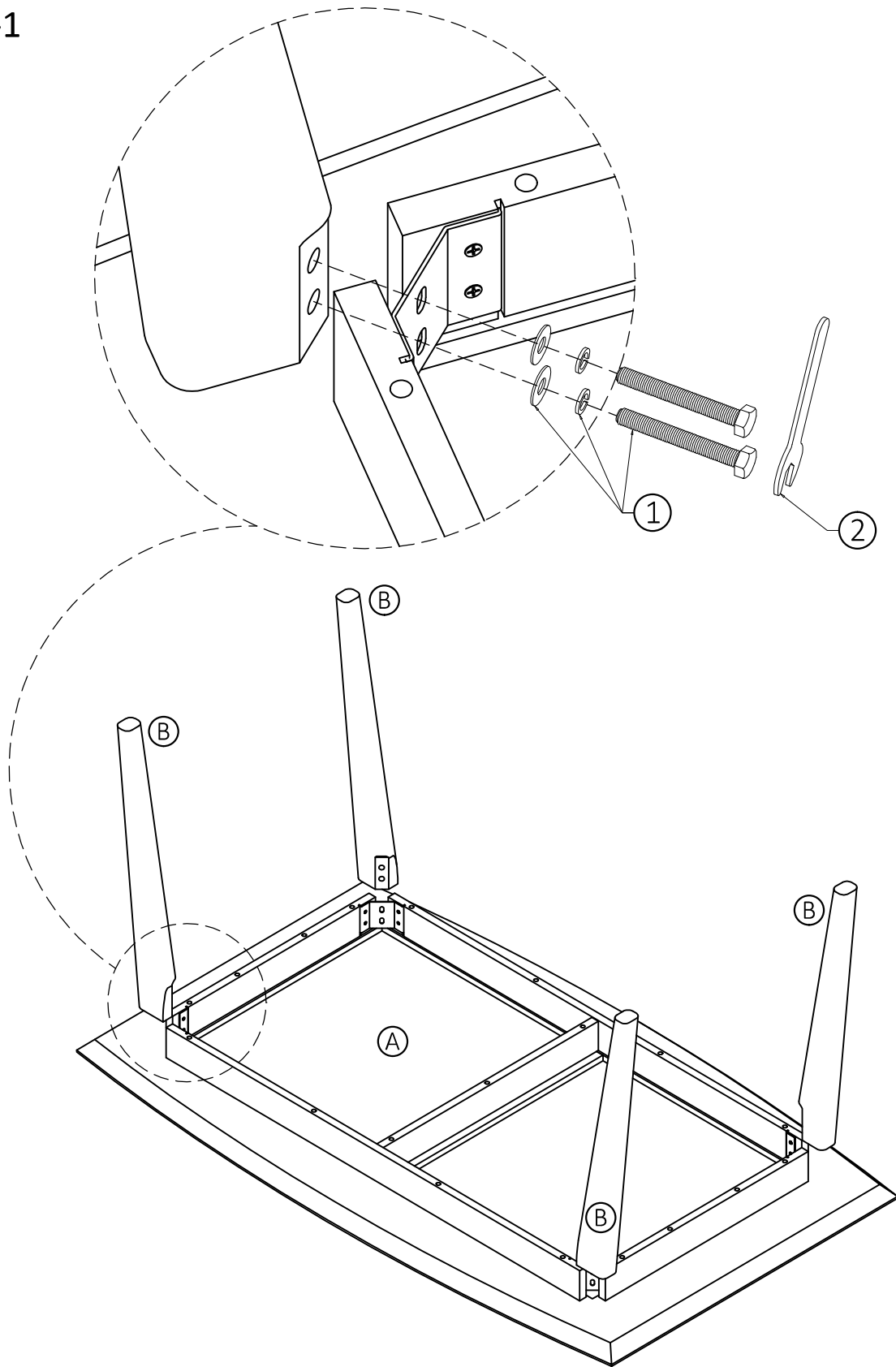

1. Attach Legs (B) to Top (A).
2. Use 8 sets Bolts and Washers (1) to secure part (A) and (B) ( 2 sets on each Leg ).
3. Use Spanner (2) to tighten Bolts. Do not over-tighten.

## PRE-ASSEMBLY INFORMATION

### STEP-2

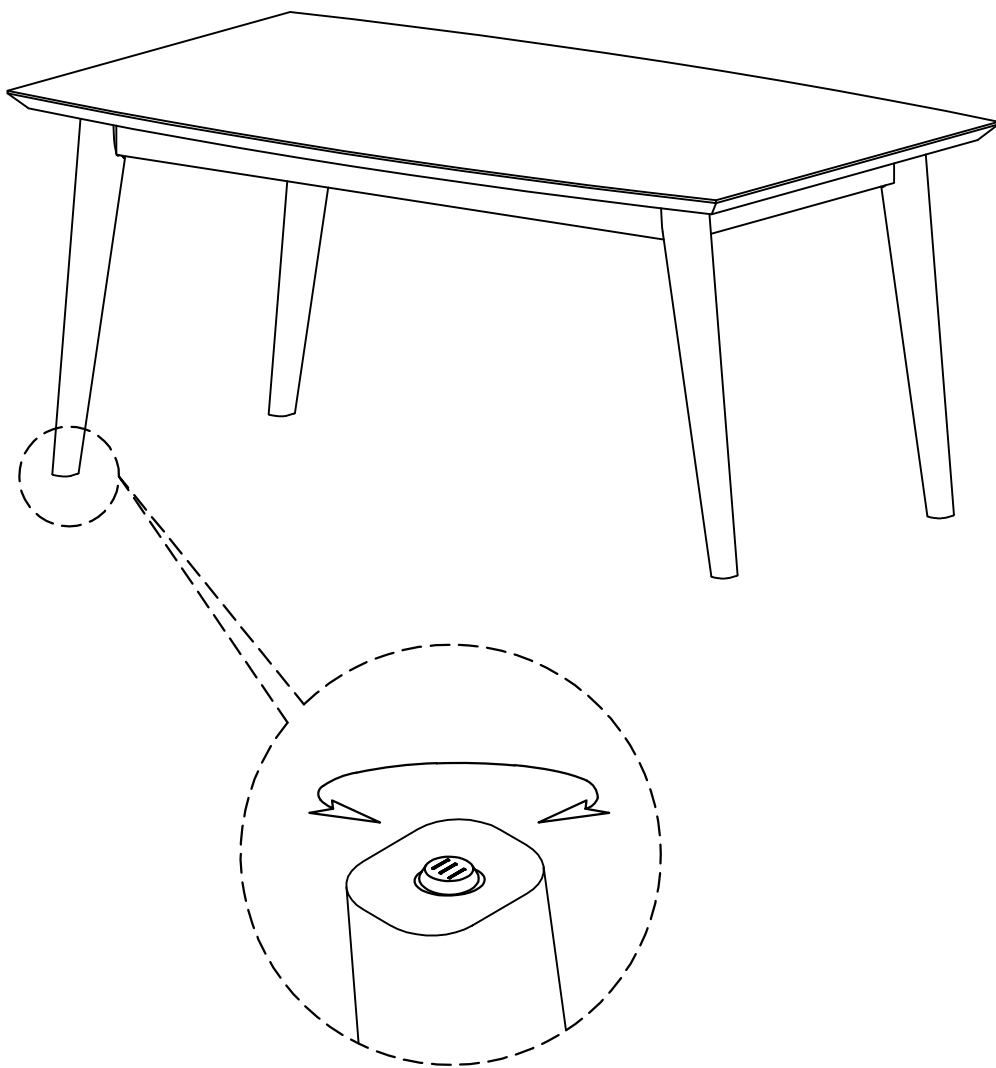

Note: Levelers on bottom of legs can be adjusted if floor is uneven.

## WARRANTY

Thank you for purchasing our product.

These products have been made to demanding, high-quality standards and are guaranteed for domestic use against manufacturing faults for a period of 12 months from the date of purchase. This warranty does not affect your statutory rights.

In case of any malfunction of your product (failure, missing parts, etc.)

We reserve the right to repair or replace the defective product, at its discretion.

This product is guaranteed for 12 months if used for normal purposes. Any warranty is invalid if the product has been overloaded or subject to neglect, improper use or an attempted repair by other than an authorized agent. Heavy-duty or daily professional/commercial usage are not guaranteed.

Due to continuous product improvement, we reserve the right to change the product specifications without prior notice.