

ASSEMBLY INSTRUCTION

Thank you for purchasing this quality product. Be sure to check all packing material carefully for small parts which may have come loose inside the carton during shipment. Separate, identify and count all parts and hardware. Compare with the parts list to be sure all parts are present.

IMPORTANT : PLEASE READ INSTRUCTION BEFORE STARTING THE ASSEMBLY.

"DO NOT TIGHTEN SCREWS UNTIL COMPLETELY ASSEMBLED"

"DO NOT OVERTIGHT ANY HARDWARE"

WARNING : SMALL PARTS AND HARDWARE NOT FOR CHILDREN UNDER 3 YEARS. ADULT ASSEMBLY REQUIRED.

TABLE OF CONTENTS

HARDWARES LIST	PAGE 2
PARTS LIST	PAGE 3
PARTS' LOCATION	PAGE 4
ASSEMBLY STEPS	PAGE 5 - 9
ASSEMBLY COMPLETED	PAGE 9

ASSEMBLY TOOLS REQUIRED

1. Screwdriver (not provide)

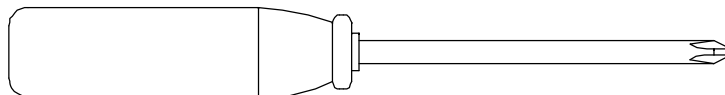



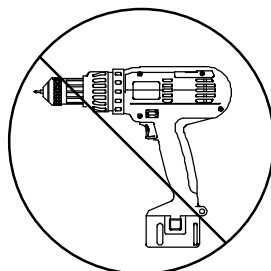



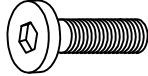
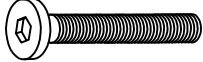
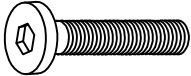

Skip the power trip this time.



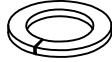

ASSEMBLY INSTRUCTION

HARDWARE LIST

ITEM	DESCRIPTION	DRAWING	QTY
A	JCBB SCREW M8 x 20MM		8 PCS
B	JCBC SCREW M6 x 35MM		14 PCS
C	JCBB SCREW M8 x 40MM		6 PCS
E	SPRING WASHER M6 x 13MM		10 PCS
F	FLAT WASHER M6 x 19MM		10 PCS
G	CSK C/B SCREW (M4 x 32MM)		8 PCS
H	M4 ALLEN KEY (65MM)		1 PC
I	M5 ALLEN KEY (65MM)		1 PC
J	SPRING WASHER M8 x 14MM		6 PCS
K	FLAT WASHER M8 x 22MM		6 PCS

ASSEMBLY INSTRUCTION

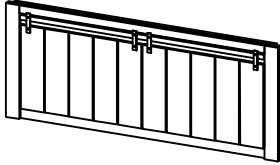
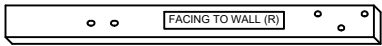
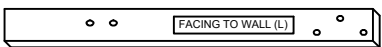
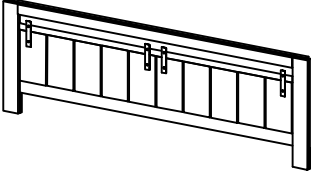
PARTS LIST (BOX 1)

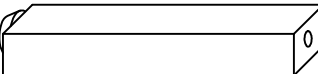
ITEM	DESCRIPTION	DRAWING	QTY
1	HEADBOARD		1 PC
2	HEADBOARD SUPPORT LEG - WITH "FACING TO WALL (R)" STICKER		1 PC
3	HEADBOARD SUPPORT LEG - WITH "FACING TO WALL (L)" STICKER		1 PC
5	FOOTBOARD		1 PC
7	SLAT		4 PCS
8	CENTRE SUPPORT LEG		4 PCS

PARTS LIST (BOX 2)

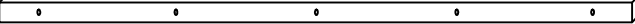
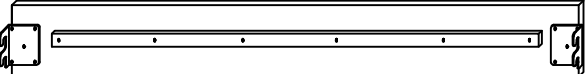
ITEM	DESCRIPTION	DRAWING	QTY
4	HEADBOARD AND FOOTBOARD TOP PANEL		2 PCS
6	SIDE RAIL		2 PCS

ASSEMBLY INSTRUCTION

PARTS ' LOCATION

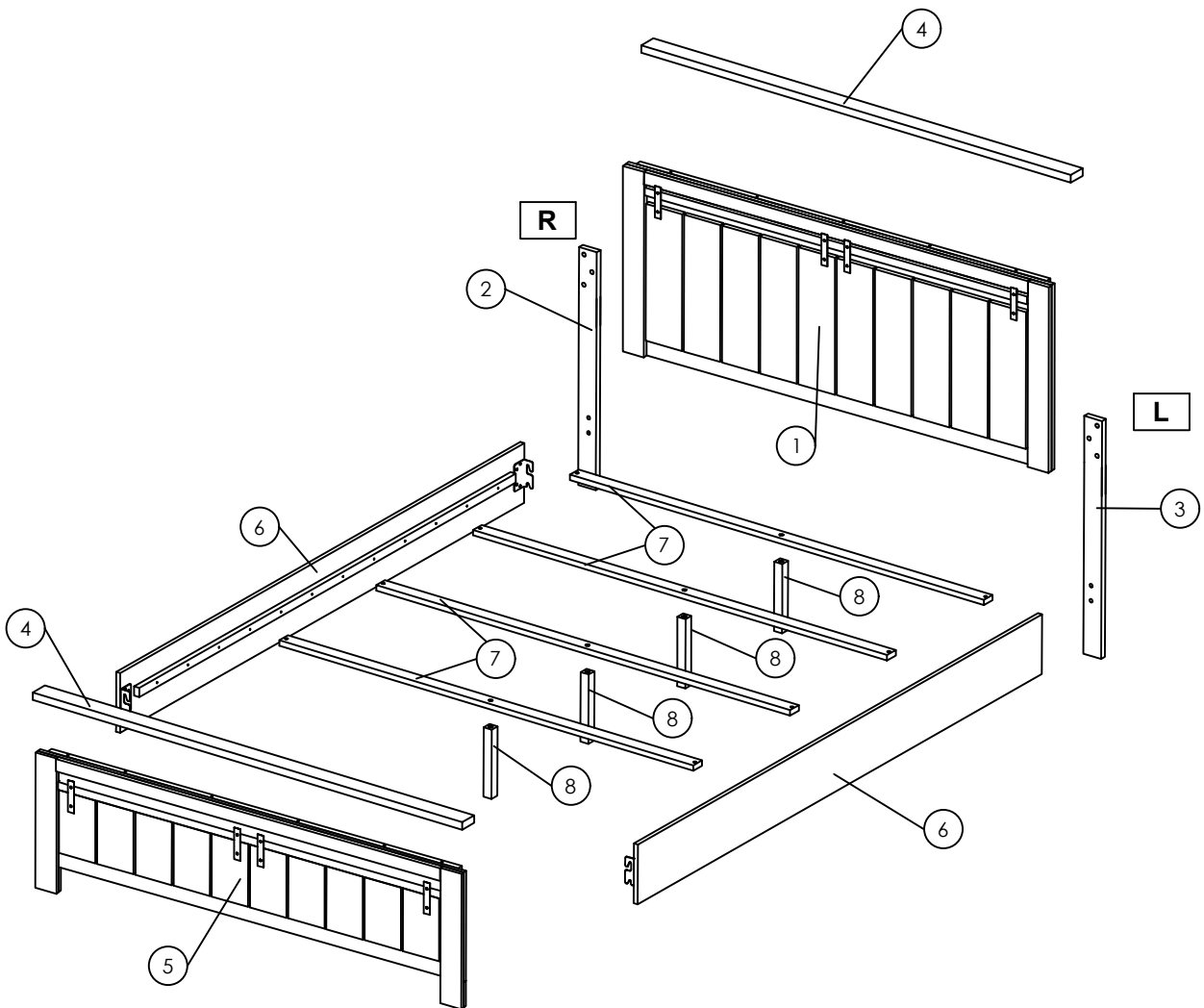

ASSEMBLY INSTRUCTION

There are two stickers pre-sticked on backside of HEADBOARD(1) which separately marked with L and R .

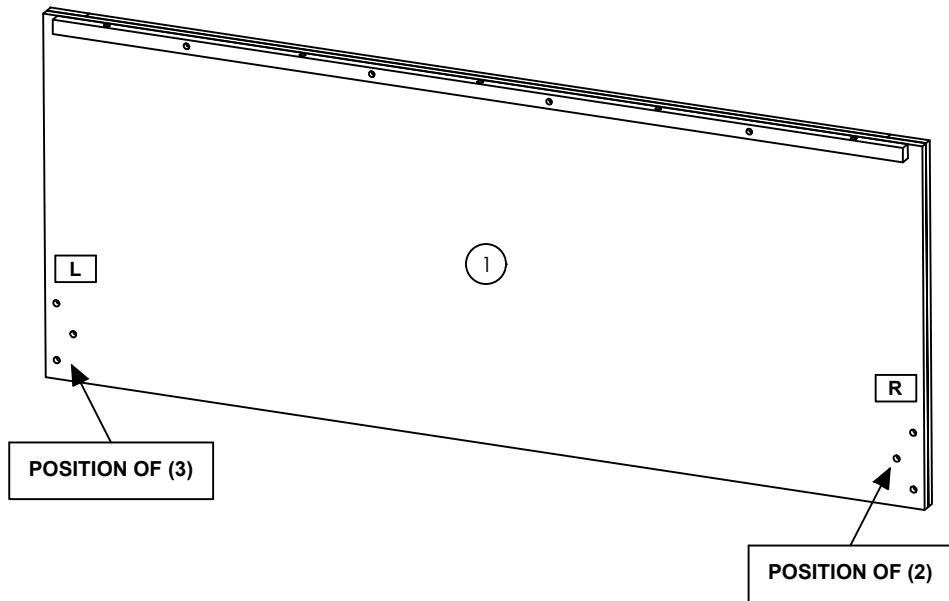

One side of (2),(3) label the sticker facing to outside during assembly.

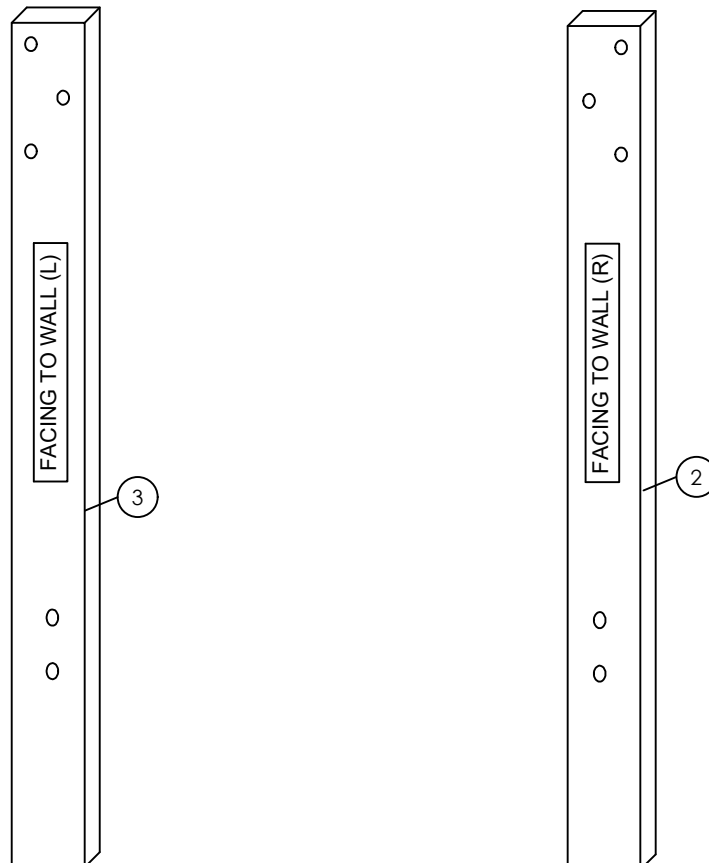

ASSEMBLY INSTRUCTION

STEP 1

Insert 1 piece (B) to combine (7) and (8) as shown. This step needs to be **done four times**.

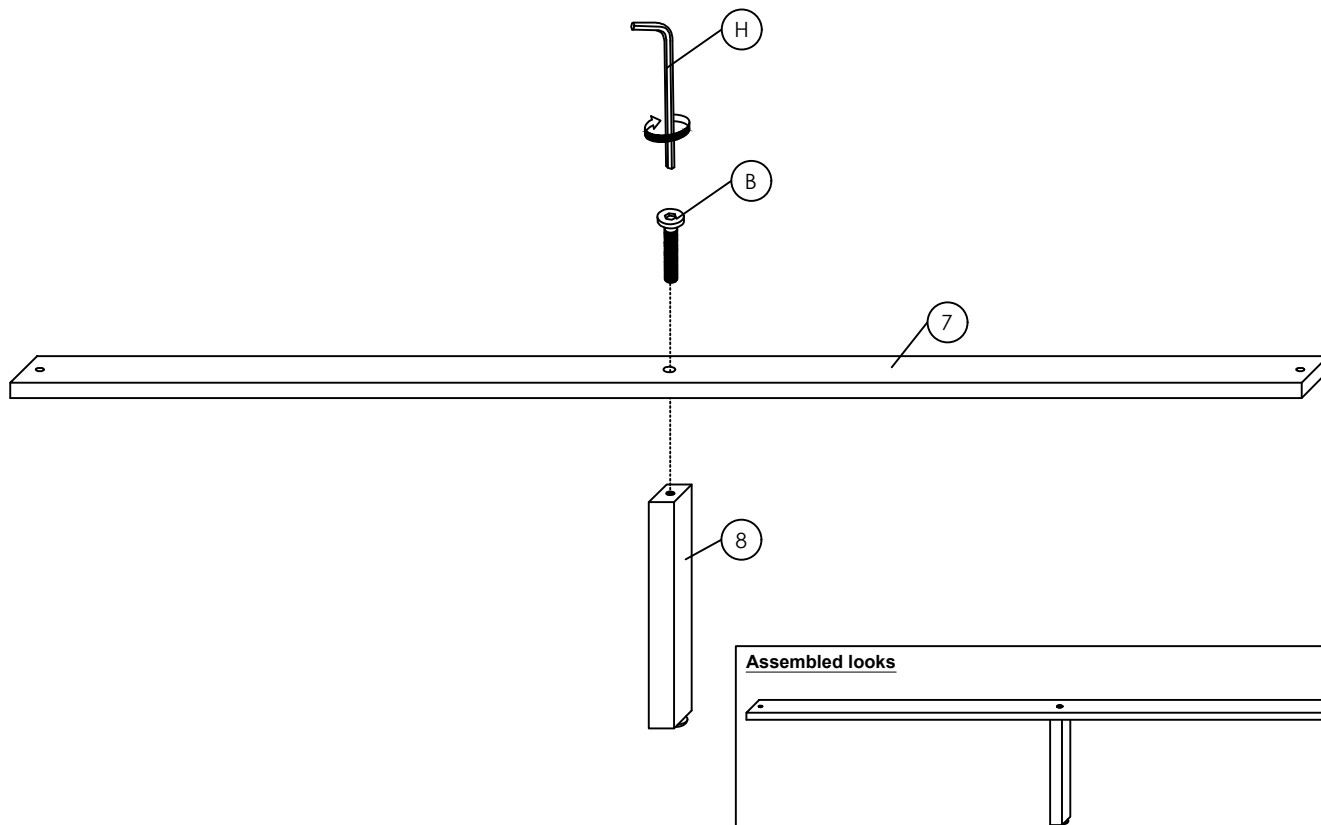

STEP 2

Insert 5 pieces (B),(E) and (F) to combine (1) and (4) as shown.

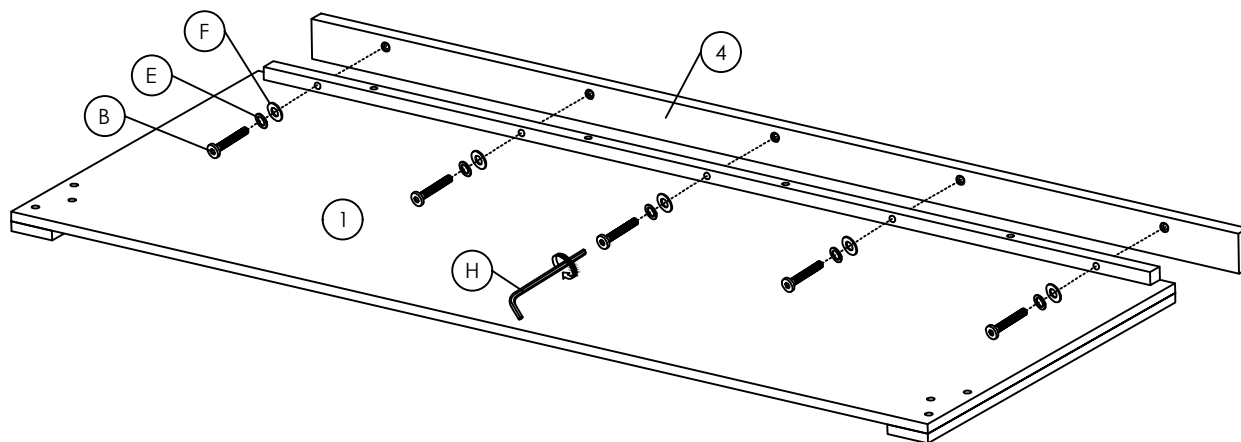

ASSEMBLY INSTRUCTION

STEP 3

Insert the 6 pieces (C), (J) and (K) to combine (2),(3) to the (1) as shown.

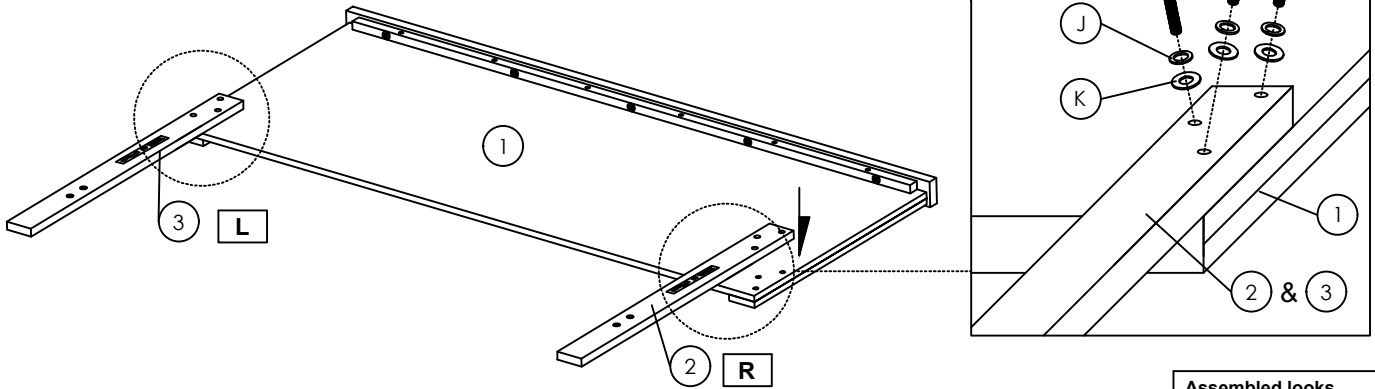

Assembled looks



STEP 4

Insert 5 pieces (B),(E) and (F) to combine (5) and (4) as shown.

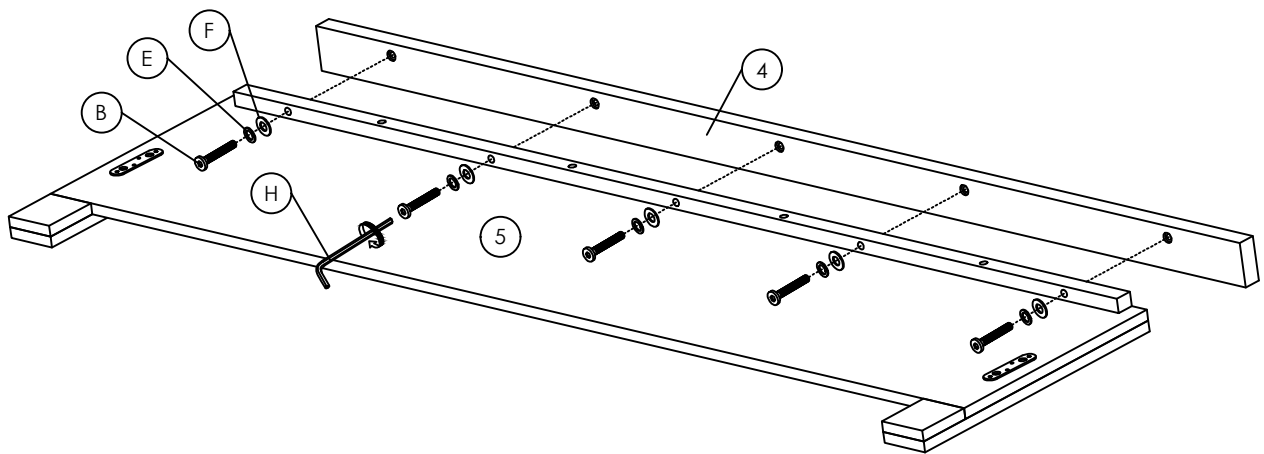

ASSEMBLY INSTRUCTION

STEP 5

Insert all the (A) to combine the (2),(3),(5) and (6) as shown.

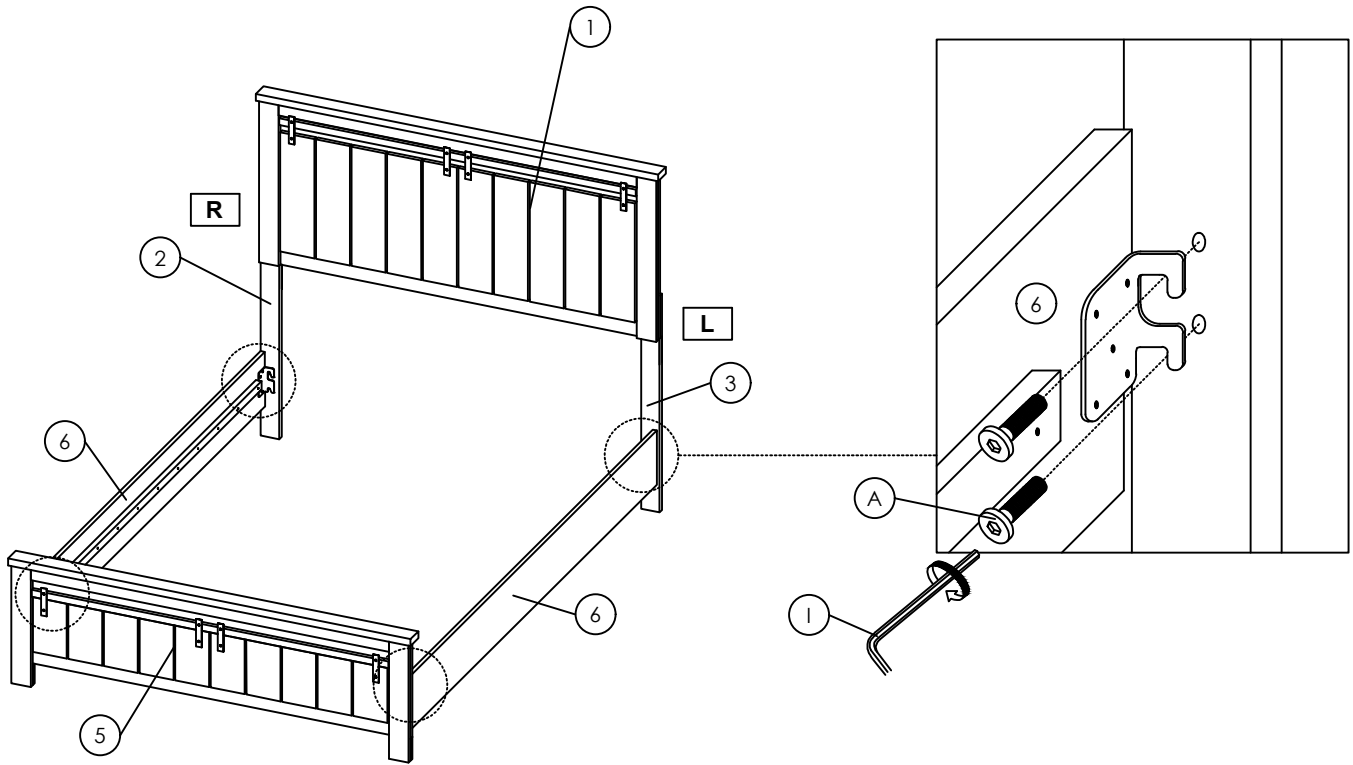

STEP 6

Put all the (7) and (8)-(combined in step 1) on the wood of (6). Then insert the 8 pieces (G) to fix it.

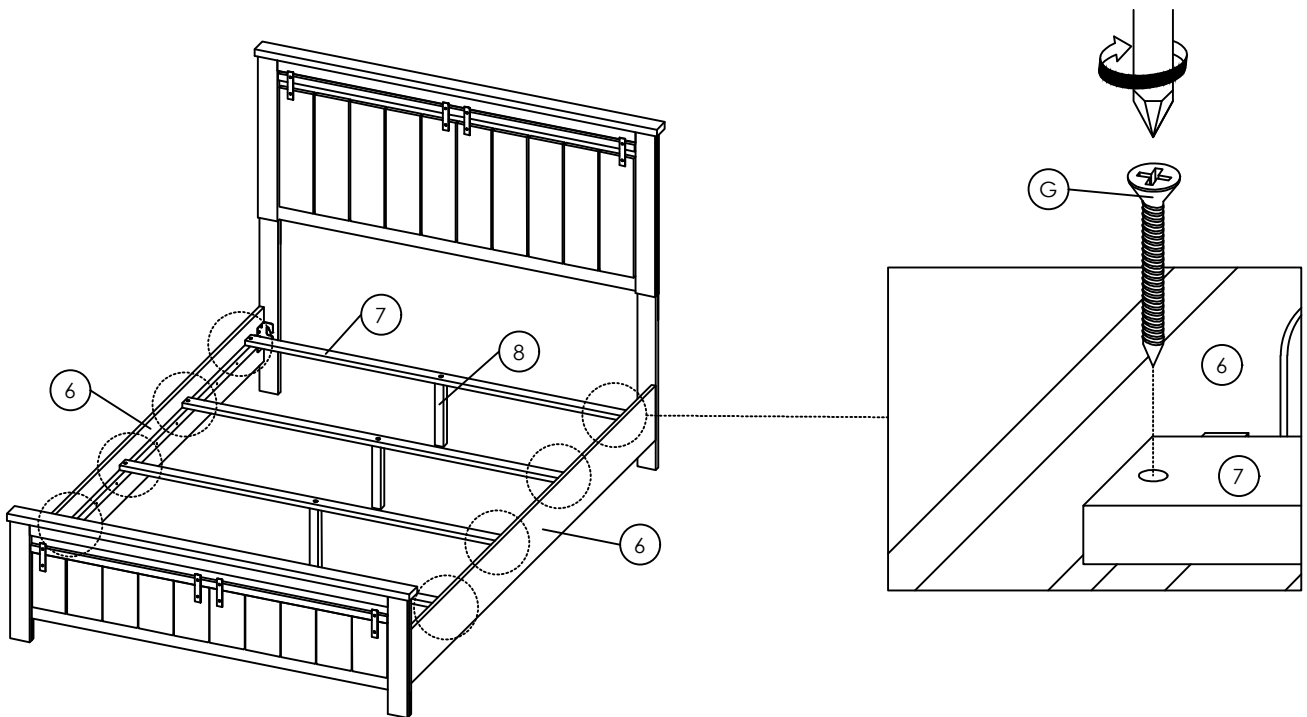

ASSEMBLY INSTRUCTION

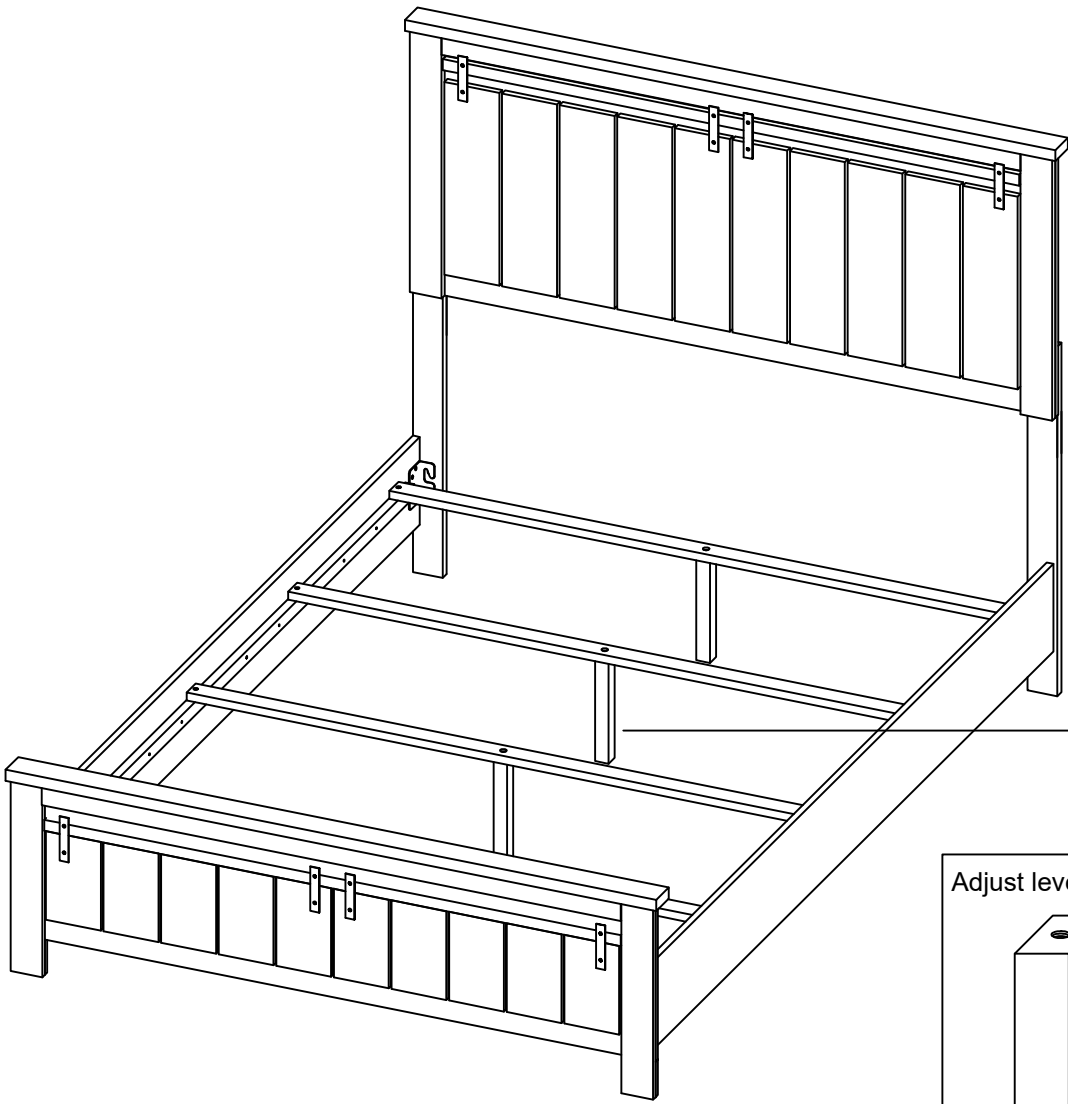

Adjust leveling feet (8) to touch floor.

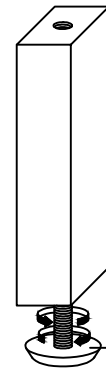

ADJUSTER SCREW

ASSEMBLY COMPLETED

** FOR ALL MODEL AND ALL SIZE BED

