

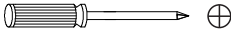

ASSEMBLY INSTRUCTIONS

30" THURSTON CANE SWIVEL BARSTOOL WITH ARM ITEM# 80142

<p>ASSEMBLY REQUIREMENTS</p>	<p>45 Minutes Assembly Time (Approximate)</p>	<p>2-Person Assembly</p>	<p>Tools Required (Not Provided)</p>	 Philips Screwdriver
-------------------------------------	---	------------------------------	--	--

Thank you for purchasing our product!

Please refer and use this assembly instruction to assemble the product. Contact our customer service department in case there are any missing or damage parts or hardware. Replacement parts are normally shipped within 2 or 3 days.

Email: replacementparts@buylateral.com
 Within 30 days from delivery date

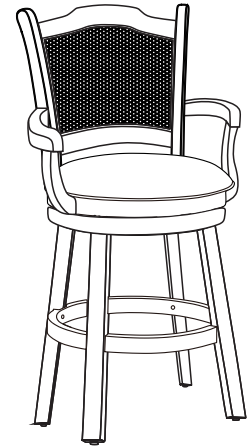

PRODUCTS PURCHASED THROUGH OUR AUTHORIZED VENDORS ONLY ARE ELIGIBLE FOR REPLACEMENT PARTS

We appreciate your business!

THIS PRODUCT IS FOR INDOOR AND HOUSEHOLD USE ONLY - NOT FOR COMMERCIAL USE.

ASSEMBLY PREPARATION

1. Remove all packaging materials, staples and packing straps from the carton.
2. Refer to Parts List and Hardware List , and ensure parts and hardware are complete before assembly.
3. Contact customer service for missing parts.
4. Place all wooden parts on a clean, flat and soft surface (e.g. carpet or rug) to prevent parts from getting scratched.

SAFETY PRECAUTION

1. KEEP ALL HARDWARE PARTS PUT OF REACH OF CHILDREN.
2. DISPOSE PLASTIC PACKAGING MATERIAL IMMEDIATELY TO AVOID ANY RISK OF SUFFOCATION TO CHILDREN AND ANIMALS.

TIPS FOR ASSEMBLY

1. Allow ample room for assembly and in close proximity to where product will be placed.
2. Assemble the product on a surface that does not scratch or damage the exterior glass and finish or the furniture.
3. Identify all of the parts, hardware and quantities required for each step.
4. During assembly, do not over-tighten any fittings as this may cause damage.
5. DO NOT USE POWER TOOLS TO ASSEMBLY THIS PRODUCT.
6. Always place the product on a flat, level surface.
7. Do not sit or stand on the partially assembled product, only use the product for which it is intended.







CARE AND MAINTENANCE

- Wipe clean with a soft, dry cloth: avoid the use of harsh chemicals or household cleaners as they may damage the exterior finish of the furniture.
- Hardware may loosen over time. Periodically, check that all connections are tight, re-tighten as necessary.
- Solid wood is impacted by heat and humidity fluctuations which may cause small joint separations or hairline cracks; place the furniture away from direct sunlight and air conditioning vents, heating vents or units to protect the furniture.









ASSEMBLY INSTRUCTIONS

30" THURSTON CANE SWIVEL BARSTOOL WITH ARM ITEM# 80142

PART LIST (FOR 1 CHAIR)

NO.	PART LIST	SKETCH	QTY.
A	TOP FRAME CUSHION		1 PC
B	BOTTOM FRAME		1 PC
C	CHAIR LEG		4 PCS
D	LEG SUPPORT		1 PC
E	ARM REST-L/R		2 PCS
F	BACKREST		1 PC

HARDWARE LIST (FOR 1 CHAIR)

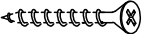
NO.	HARDWARE LIST		QTY.	QTY.
G	JCBC BOLT M6 X 50MM		8 PCS	1 PC
H	JCBC BOLT M6 X 40MM		6 PCS	1 PC
I	JCBC BOLT M6 X 35MM		2 PCS	1 PC
J	JCBC BOLT M6 X 25MM		4 PCS	1 PC
K	SPRING WASHER M6		20 PCS	1 PC
L	FLAT WASHER M6		8 PCS	1 PC
M	ALLEN KEY M4		1 PC	
N	NAIL LEG			1 PC
O	CSK SCREW M4 X 38MM		2 PCS	1 PC

***EXTRA HARDWARE FOR SPARE USE**

STEP 1

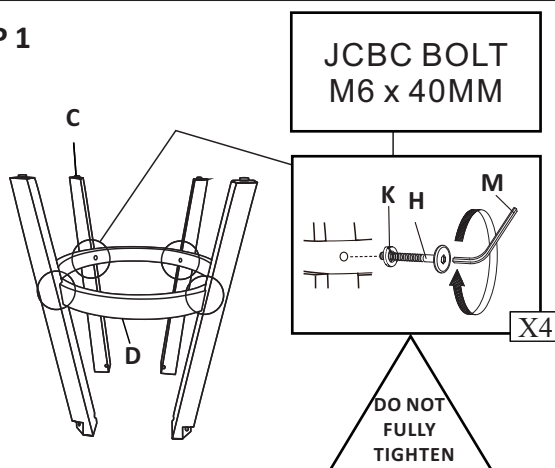

- a) Fasten Leg (C) to Leg Support (D) as shown using JCBC Bolt (H) fitted with Spring Washer (K). Use Allen Key (M) to drive and tighten (H). **Do not tighten (H) completely at this time.**

ASSEMBLY INSTRUCTIONS

30" THURSTON CANE SWIVEL BARSTOOL WITH ARM ITEM# 80142

STEP 2

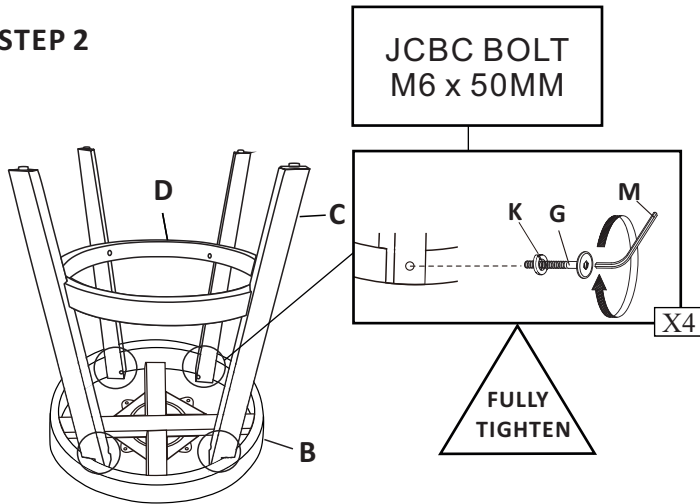

- a) Lay Bottom Frame (B) bottom-side up as shown.
- b) Use JCBC Bolt (G) fitted with Spring Washer (K) to fasten Leg (C) from STEP 1 to (B) as shown. Drive and tighten (G) with Allen Key (M). Do not tighten (G) completely until all the bolts are in place on each leg. **Do not over-tightened the bolts.**
- c) **Tighten JCBC Bolt (H) in STEP 1 completely at this time. Do not over-tightened the bolts.**

STEP 3

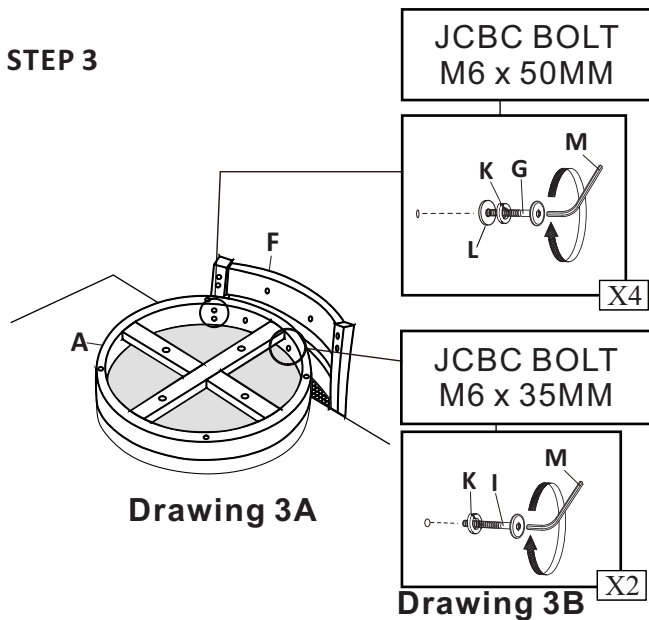

Drawing 3C

- a) Lay Top Frame Cushion (A) bottom-side up on an elevated surface (e.g. table top) as shown in Drawing 3A and align the bolt holes on (A) to the bolts on Backrest (F).
- b) Refer to Drawing 3B - Fit each JCBC Bolt (I) with Spring Washer (K) and insert (I) through the central two holes to fasten (A) to (F). Drive (I) with Allen Key (M). **Do not tighten (I) completely at this time.**
- c) Refer to Drawing 3C - Fit each JCBC Bolt (G) with Spring Washer (K) and Flat Washer (L) and insert (G) through the paired holes on (A) to fasten to the left and right edge of (F). Drive (G) with Allen Key (M). **Do not tighten (G) completely until all 4 bolts are in place.**
- d) **Tighten Bolt (I) completely at this time.**

STEP 4

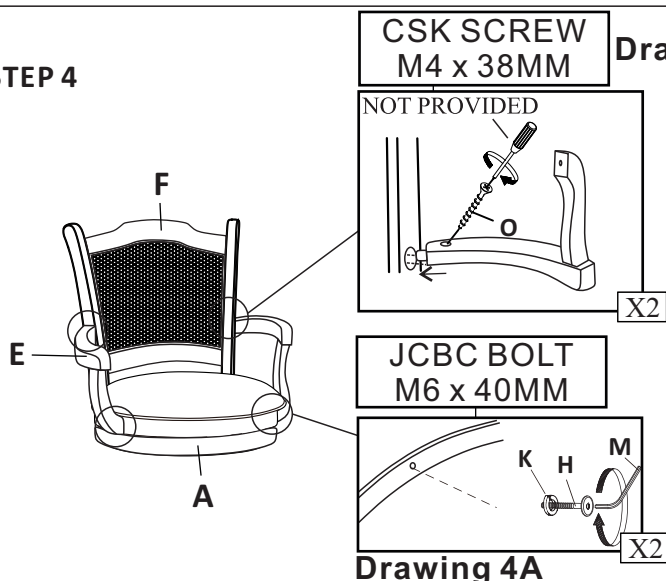

Drawing 4B

- a) Refer to Drawing 4A - Fasten vertical arm of Armrest (E) to Top Frame Cushion (A) using JCBC Bolt (H) fitted with Spring Washer (K). **NOTE: Both (E) and (A) with labelled R & L sticker.** Use Allen Key (M) to drive and tighten (H). **Do not tighten (H) completely at this time.**
- b) Refer to Drawing 4B - Attach horizontal arm of (E) to Backrest (F) and fasten with Screw (O). Use a screwdriver to drive (O). **Tighten (O) completely but do not over tighten.**
- c) **Fasten Bolt (H) completely at this time.**

ASSEMBLY INSTRUCTIONS

30" THURSTON CANE SWIVEL BARSTOOL WITH ARM ITEM# 80142

STEP 5

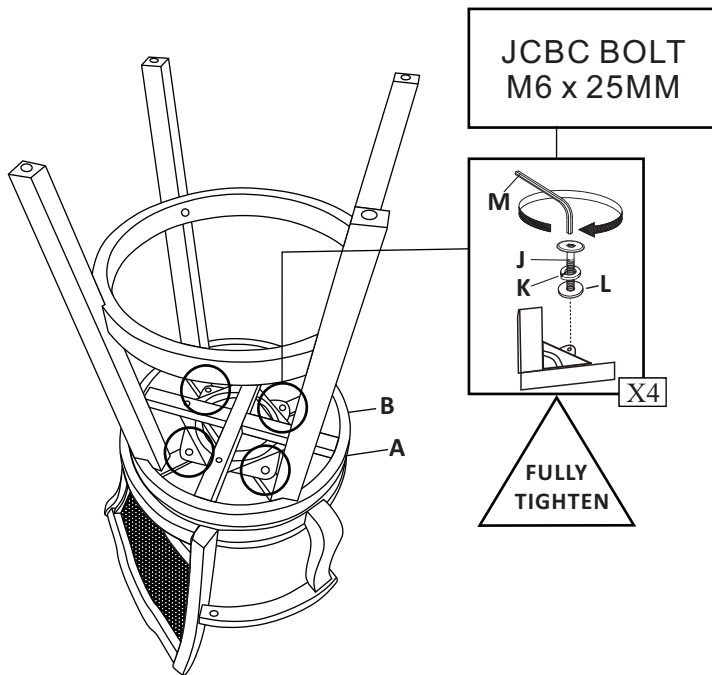

- With assistance, attach leg assembly from STEP 2 to Top Frame Cushion (A) in STEP 4 as shown.
- Align the four bolt holes on Swivel Plate on Bottom Frame (B) to the four bolt holes on (A).
- Use JCBC Bolt (J) fitted with Spring Washer (K) and Flat Washer (L) to fasten the Swivel Plate on Bottom Frame (B) to Top Frame Cushion (A). Drive (J) with Allen Key (M). Do not tighten (J) completely until all four bolts are in place.

STEP 6

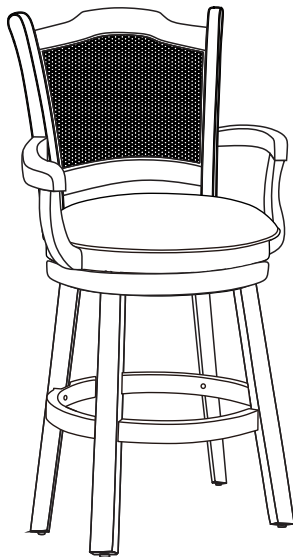

- Check to ensure all of the bolts and screws are tightened properly. Do not over-tightening the bolts and screws.
- Set the barstool right-side up.

The assembly of the barstool is complete.