

ASSEMBLY INSTRUCTIONS

DINING TABLE

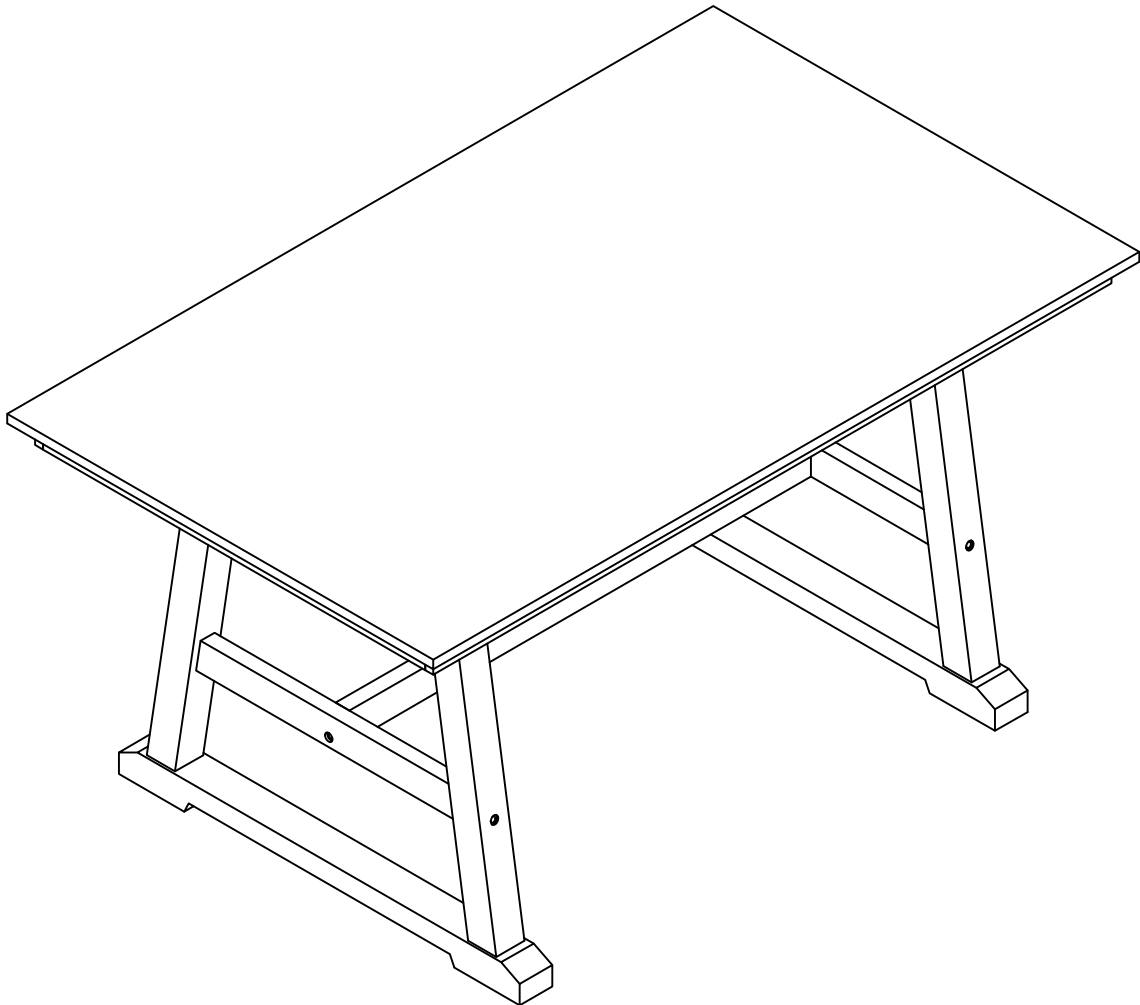

IMPORTANT NOTE :

- 1 PLACE ALL PARTS ON A CLEAN AND SMOOTH SURFACE SUCH AS A RUG OR CARPET TO AVOID THE PARTS FROM BEING SCRATCHED.**
- 2 BEFORE YOU BEGIN , KINDLY FOLLOW THE ASSEMBLY INSTRUCTIONS STEP BY STEP.**
- 3 DO NOT TIGHTEN ALL SCREWS AND BOLTS UNTIL THE TABLE IS FULLY SET-UP**

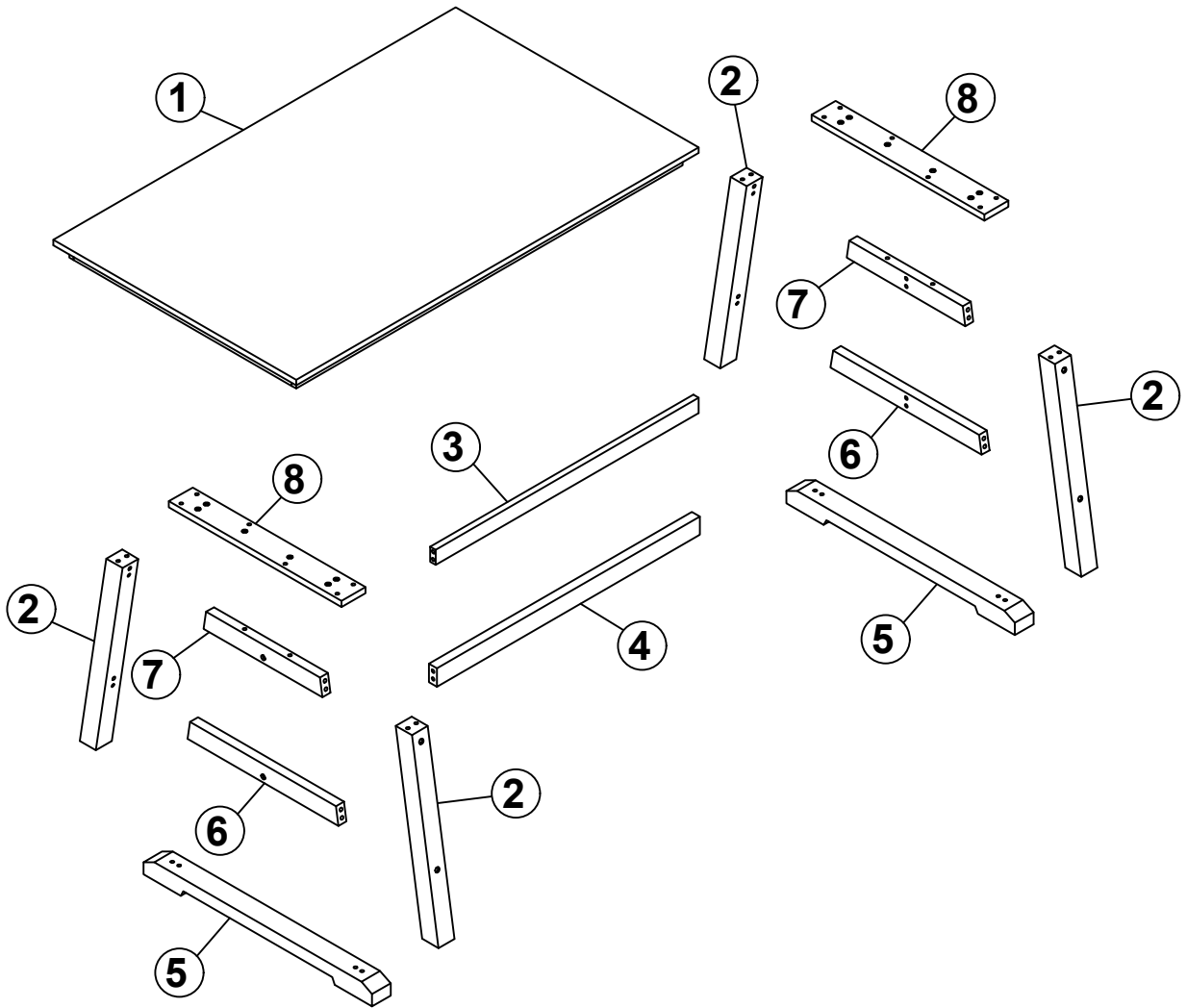

PART LIST

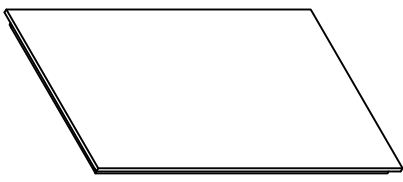
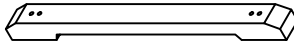
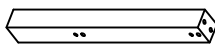
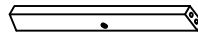
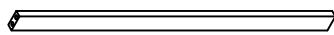
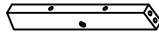
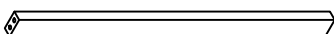
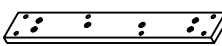
<p>①</p> 	<p>⑤</p> 
<p>TOP TABLE (1pc)</p>	<p>BASE (2pcs)</p>
<p>②</p> 	<p>⑥</p> 
<p>LEGS TABLE (4pcs)</p>	<p>STRETCHER (2pcs)</p>
<p>③</p> 	<p>⑦</p> 
<p>STRETCHER (1pc)</p>	<p>STRETCHER (2pcs)</p>
<p>④</p> 	<p>⑧</p> 
<p>STRETCHER (1pc)</p>	<p>CROSSBAR (2pcs)</p>

ASSEMBLY INSTRUCTIONS

HARDWARE LIST

A



Ø5/16" x 80mm
BOLT (12pcs)

C



Ø5/16" x 35mm
BOLT (12pcs)

B



Ø5/16" x 45mm
BOLT (16pcs)

D



Ø10" x 40mm
WOODEN PEGS (16pcs)

J



4 x 58mm

ALLENKEY (1pc)

F



ADJUSTABLE FEET (4pcs)

Step 1

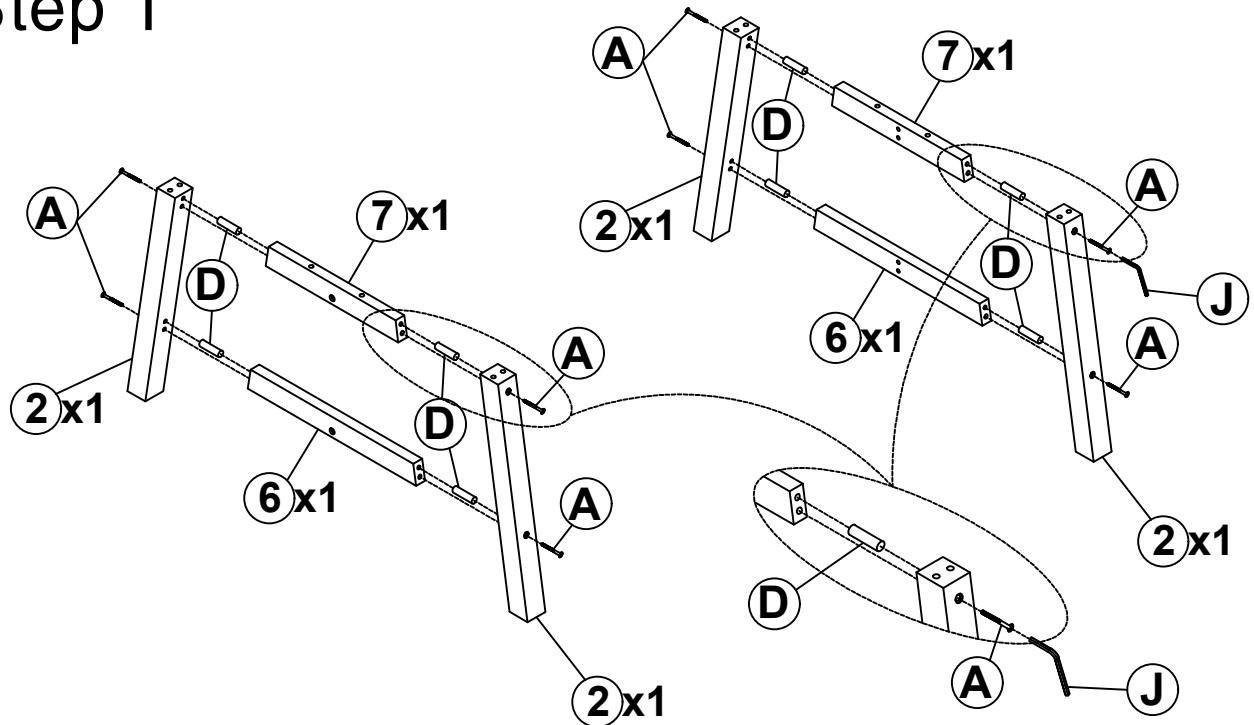



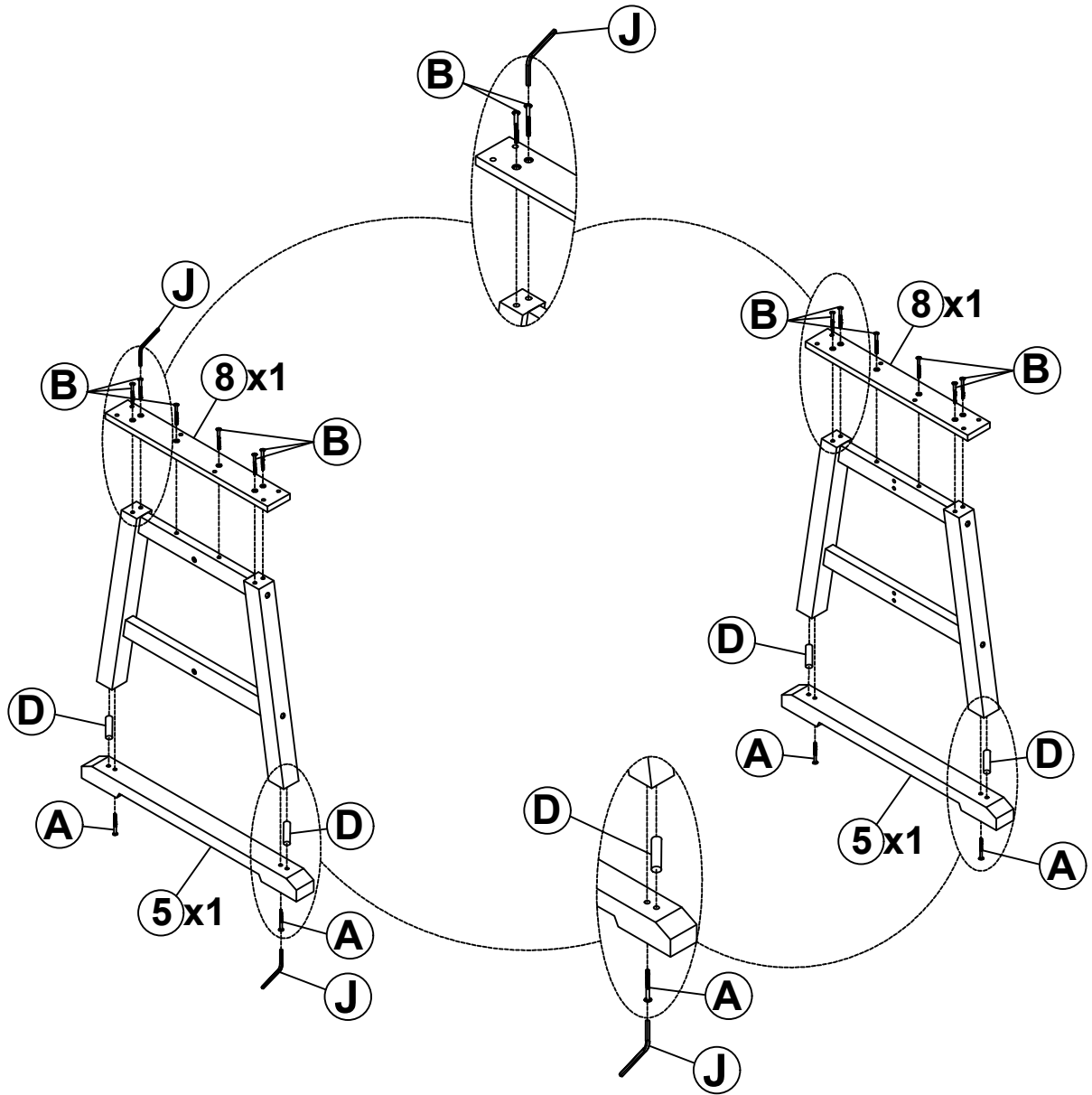

D	Ø10x40		8PCS	J	4x58		1PC	A	5/16x80		8PCS
----------	--------	--	------	----------	------	--	-----	----------	---------	--	------

ASSEMBLY INSTRUCTIONS

Step 2





J	4x58		1PC	D	Ø10x40		4PCS
B	5/16x45		12PCS	A	5/16x80		4PCS

ASSEMBLY INSTRUCTIONS

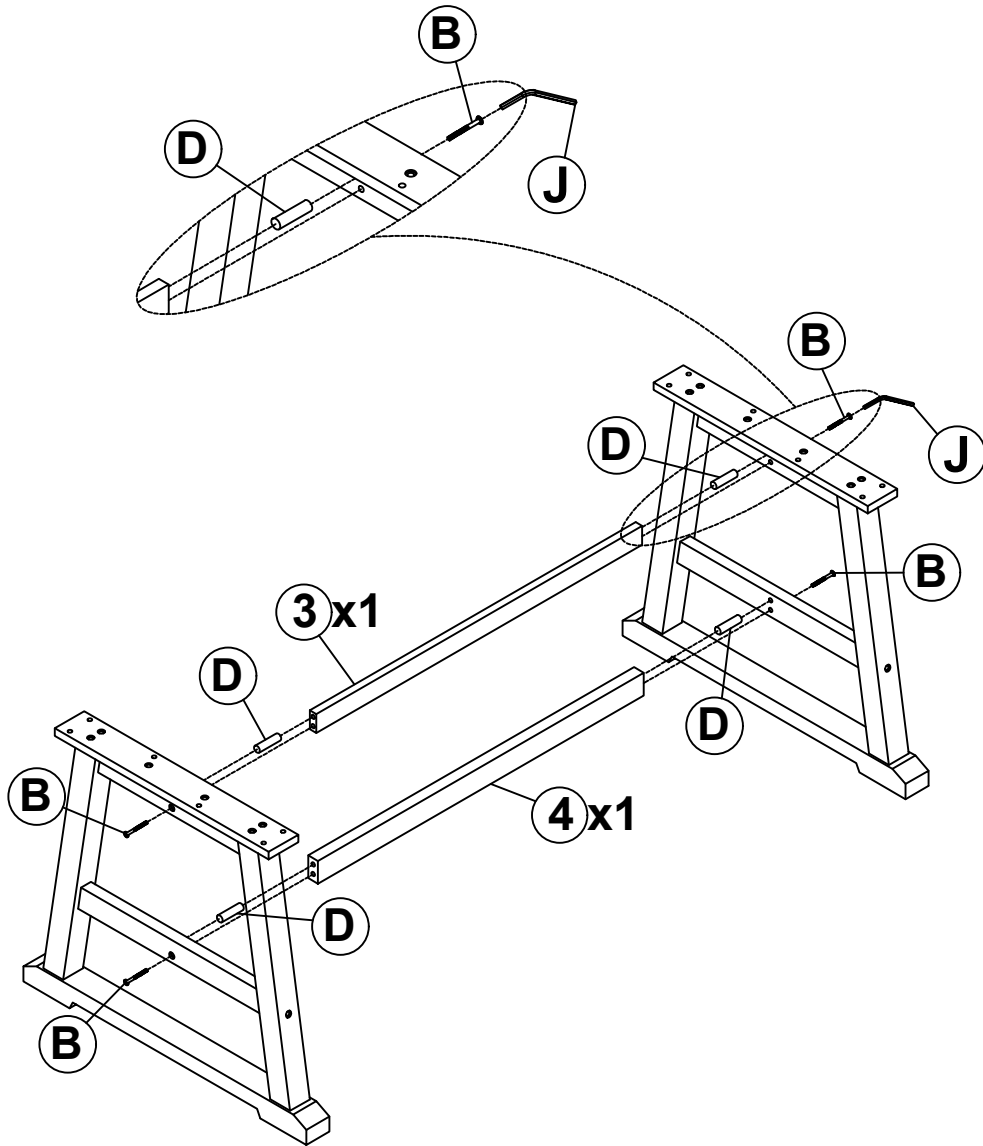
Step 3

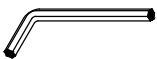



J	4x58		1PC			
B	5/16x45		4PCS	D	Ø10x40	 4PCS

ASSEMBLY INSTRUCTIONS

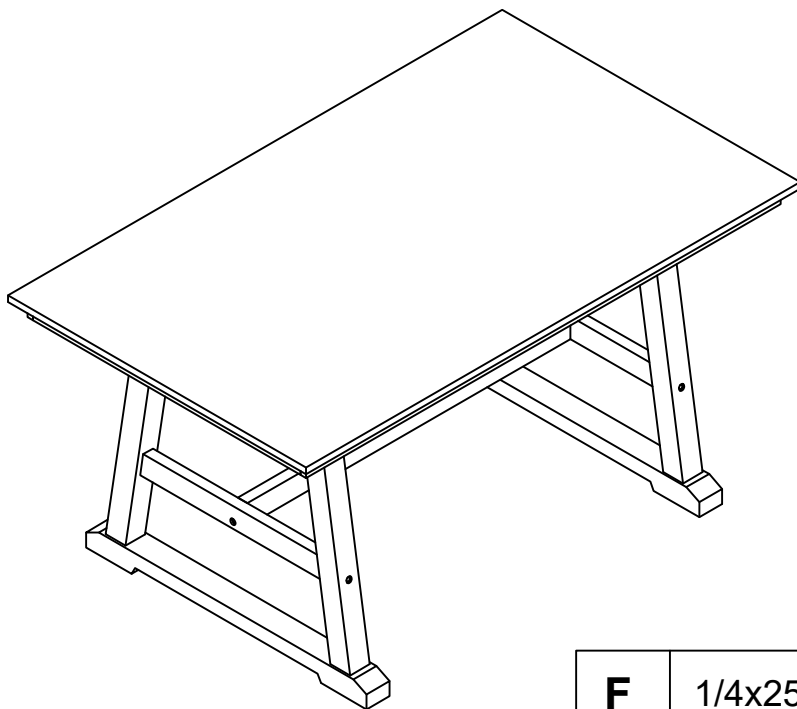
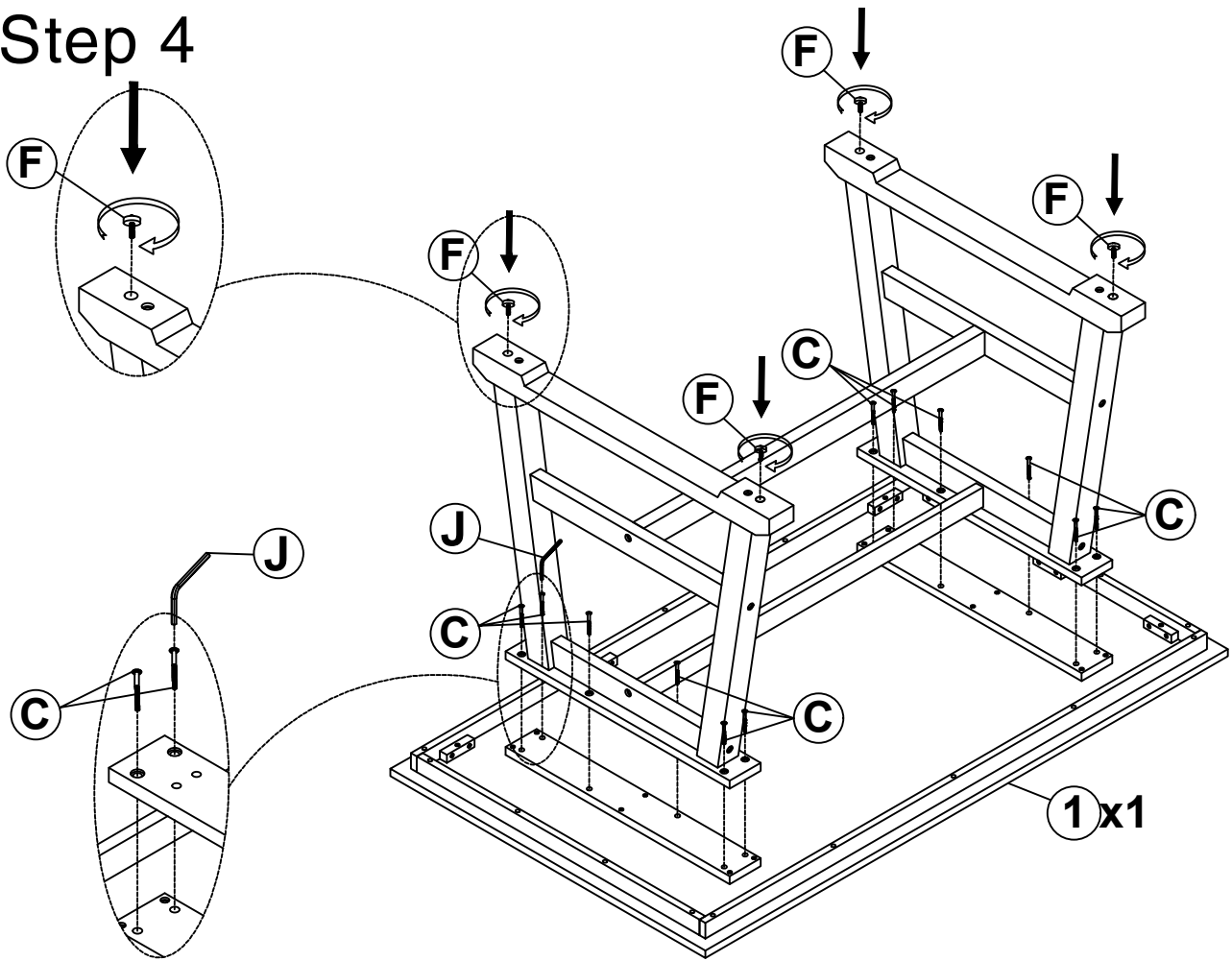
Step 4



F	1/4x25		4PCS
C	5/16x35		12PCS
J	4x58		1PC

ASSEMBLY INSTRUCTIONS



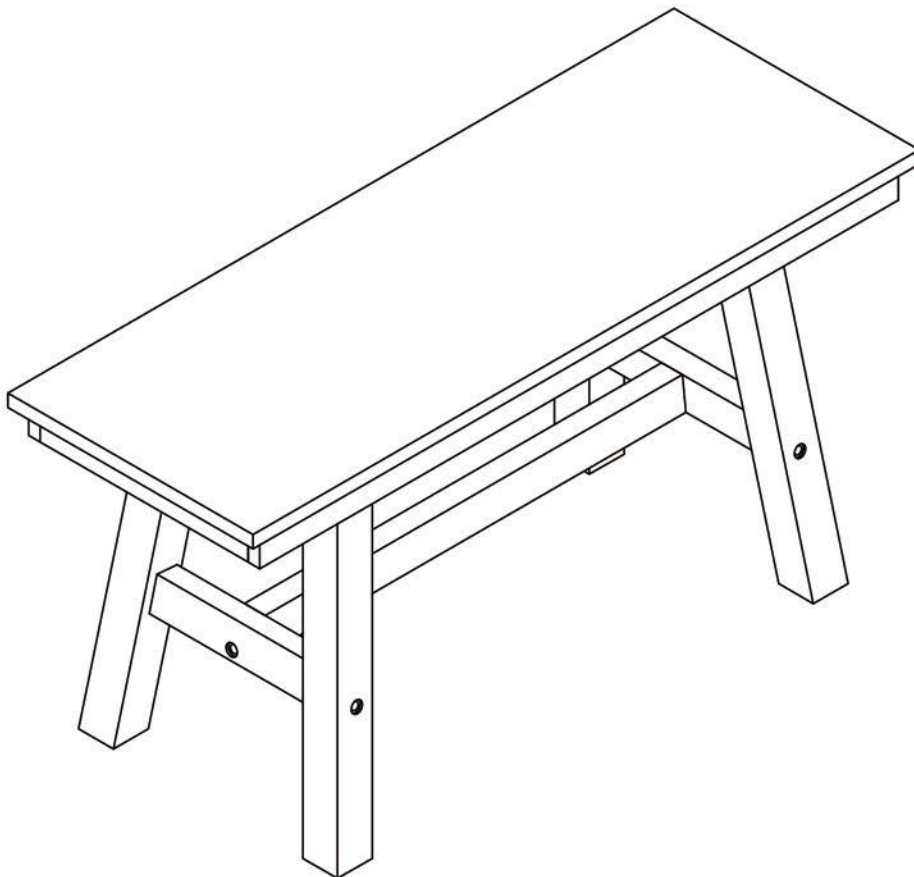





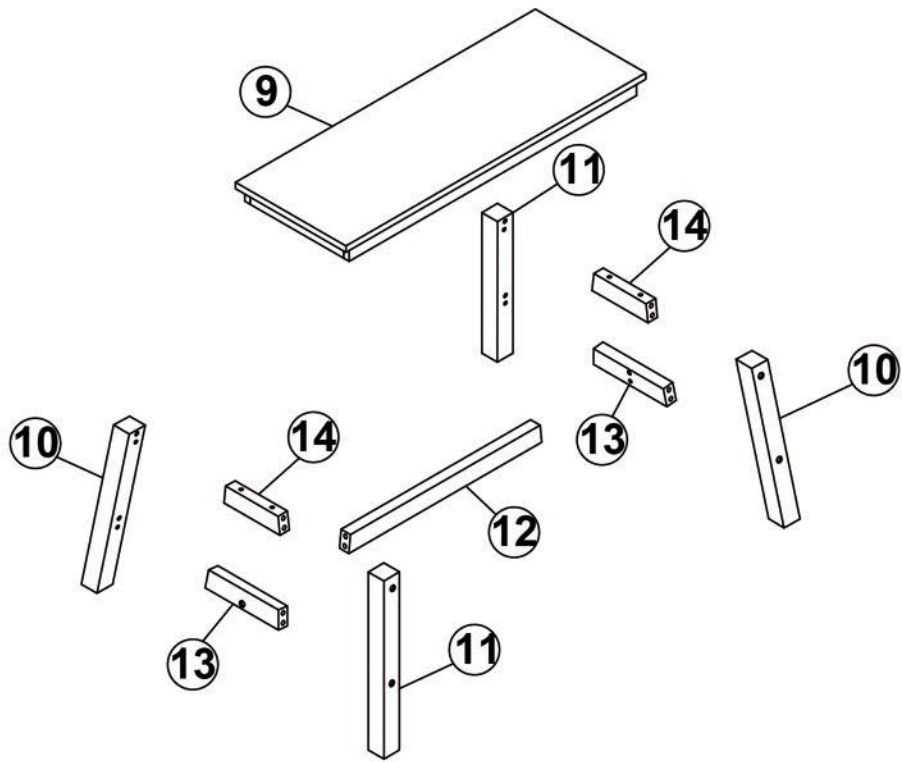

DINING BENCH

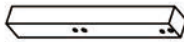

IMPORTANT NOTE :

- ① PLACE ALL PARTS ON A CLEAN AND SMOOTH SURFACE SUCH AS A RUG OR CARPET TO AVOID THE PARTS FROM BEING SCRATCHED.
- ② BEFORE YOU BEGIN , KINDLY FOLLOW THE ASSEMBLY INSTRUCTIONS STEP BY STEP.
- ③ DO NOT TIGHTEN ALL SCREWS AND BOLTS UNTIL THE BENCH IS FULLY SET-UP





PART LIST FOR ONE BENCH		HARDWARE LIST FOR ONE BENCH	
9		E	
	SEAT BENCH (1pc)		Ø5/16" x 65mm
10			BOLT (12pcs)
	LEGS BENCH (2pcs)	B	
11			Ø1/4" x 45mm
	LEGS BENCH (2pcs)		BOLT (2pcs)
12		D	
	STRETCHER (1pc)		Ø10" x 40mm
13			WOODEN PEGS (10pcs)
	STRETCHER (2pcs)	J	
14			4 x 58mm
	STRETCHER (2pcs)		ALLENKEY (1pc)

ASSEMBLY INSTRUCTIONS

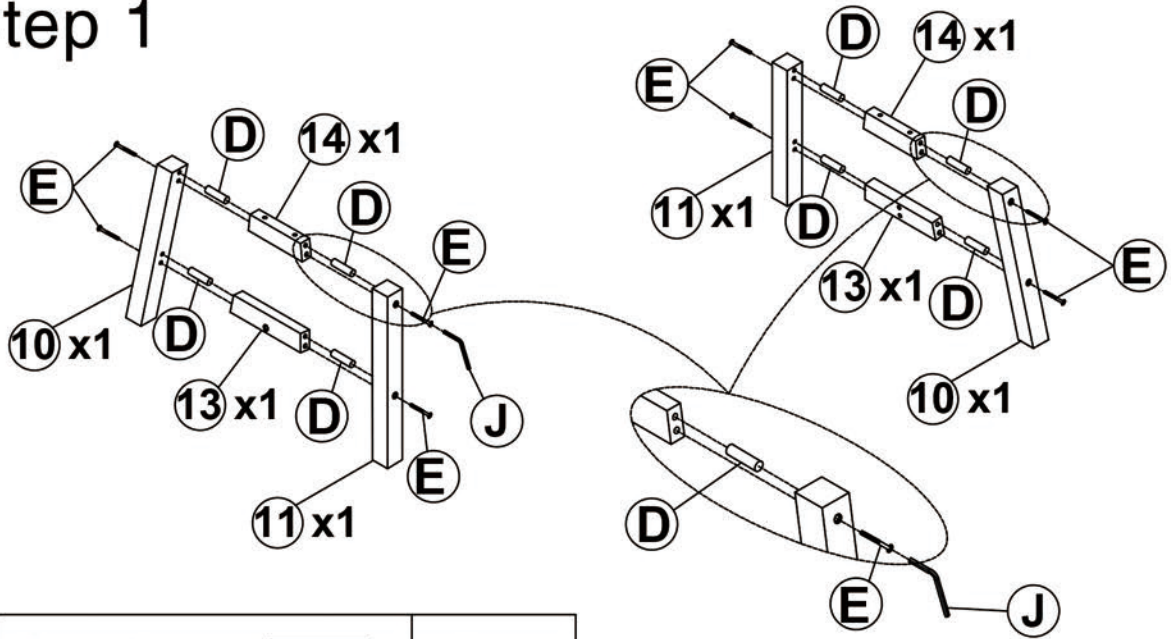

Step 1

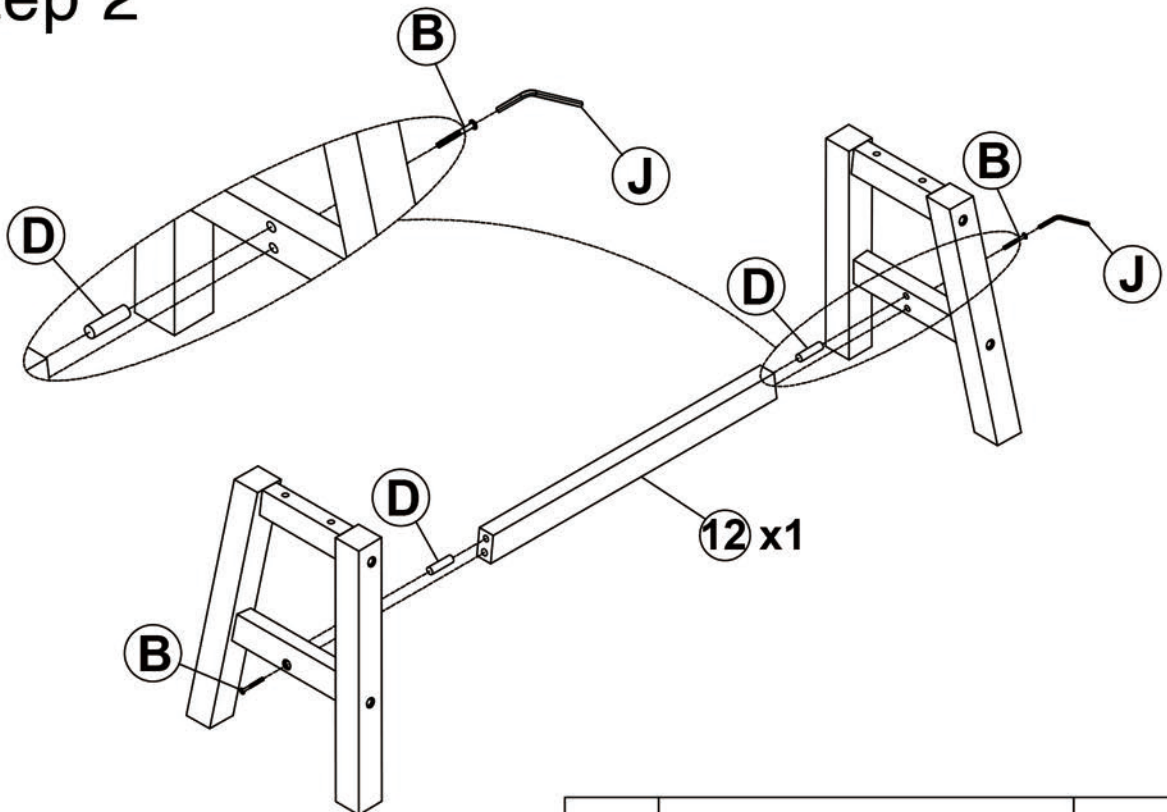

D	Ø10x40		8PCS				
J	4x58		1PC	E	5/16x65		8PCS

Step 2



				D	Ø10x40		2PCS
B	1/4x45		2PCS	J	4x58		1PC

ASSEMBLY INSTRUCTIONS

Step 3

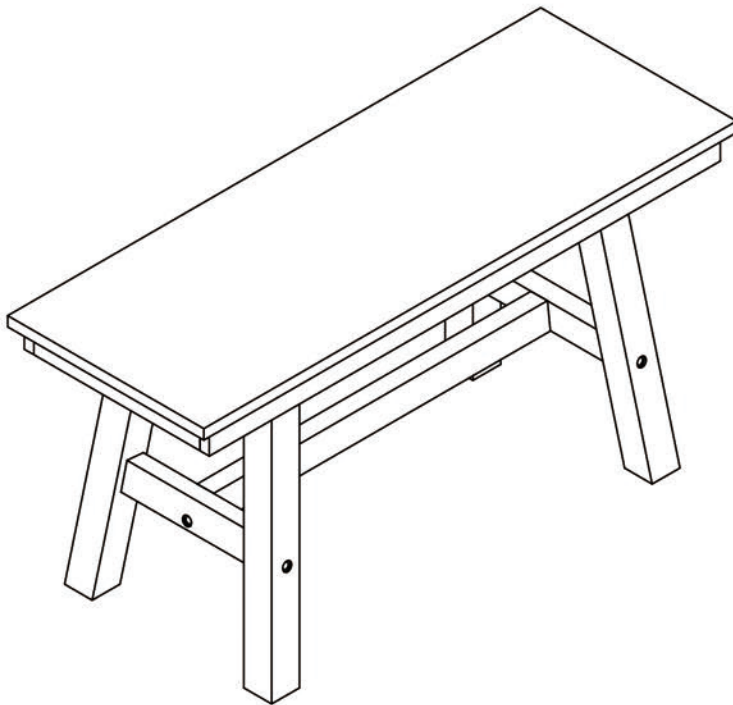
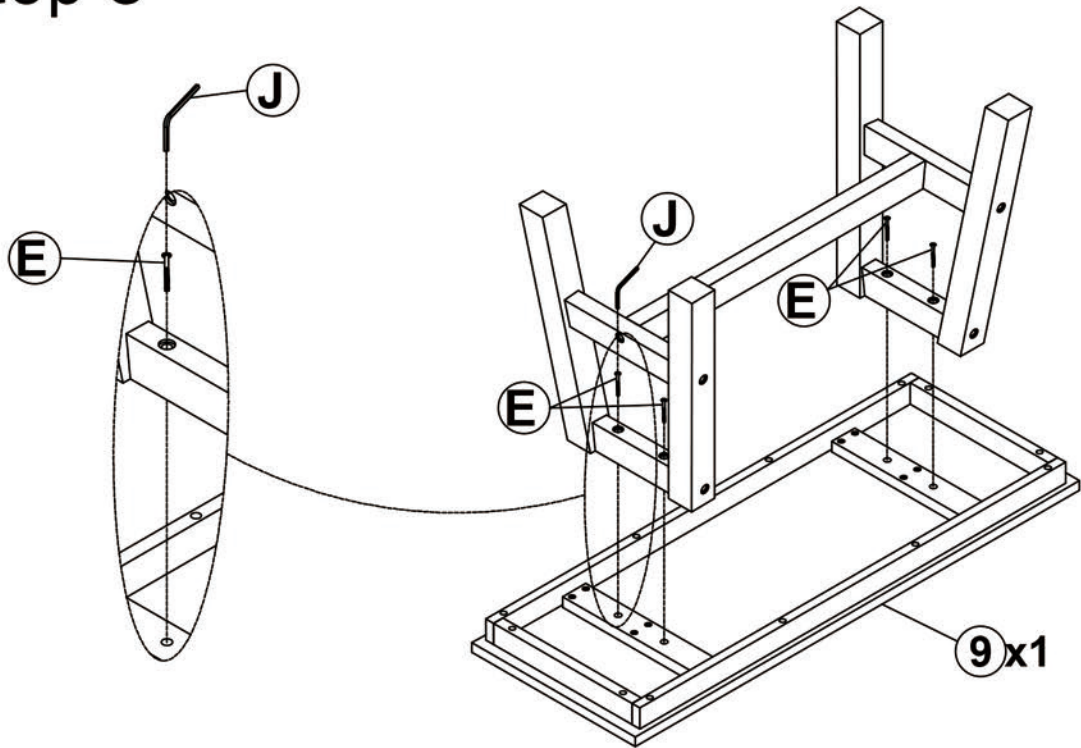

J 4x58



1PC

E 5/16x65



4PCS

ASSEMBLY INSTRUCTIONS

DINING CHAIR

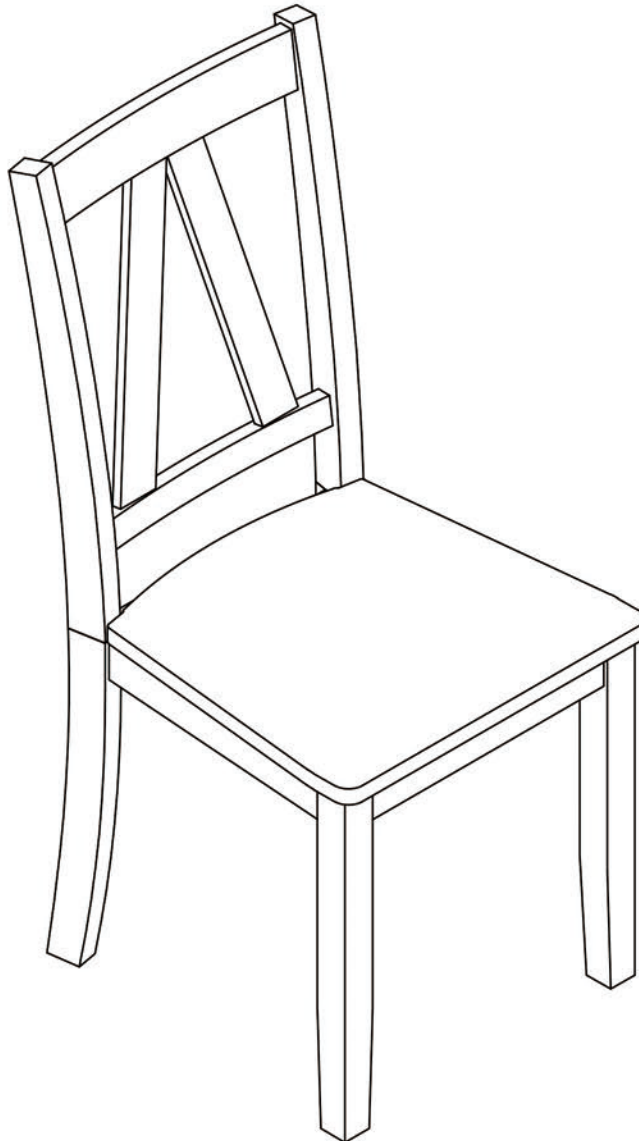

IMPORTANT NOTE :

- 1 PLACE ALL PARTS ON A CLEAN AND SMOOTH SURFACE SUCH AS A RUG OR CARPET TO AVOID THE PARTS FROM BEING SCRATCHED.**
- 2 BEFORE YOU BEGIN , KINDLY FOLLOW THE ASSEMBLY INSTRUCTIONS STEP BY STEP.**
- 3 DO NOT TIGHTEN ALL SCREWS AND BOLTS UNTIL THE CHAIR IS FULLY SET-UP**

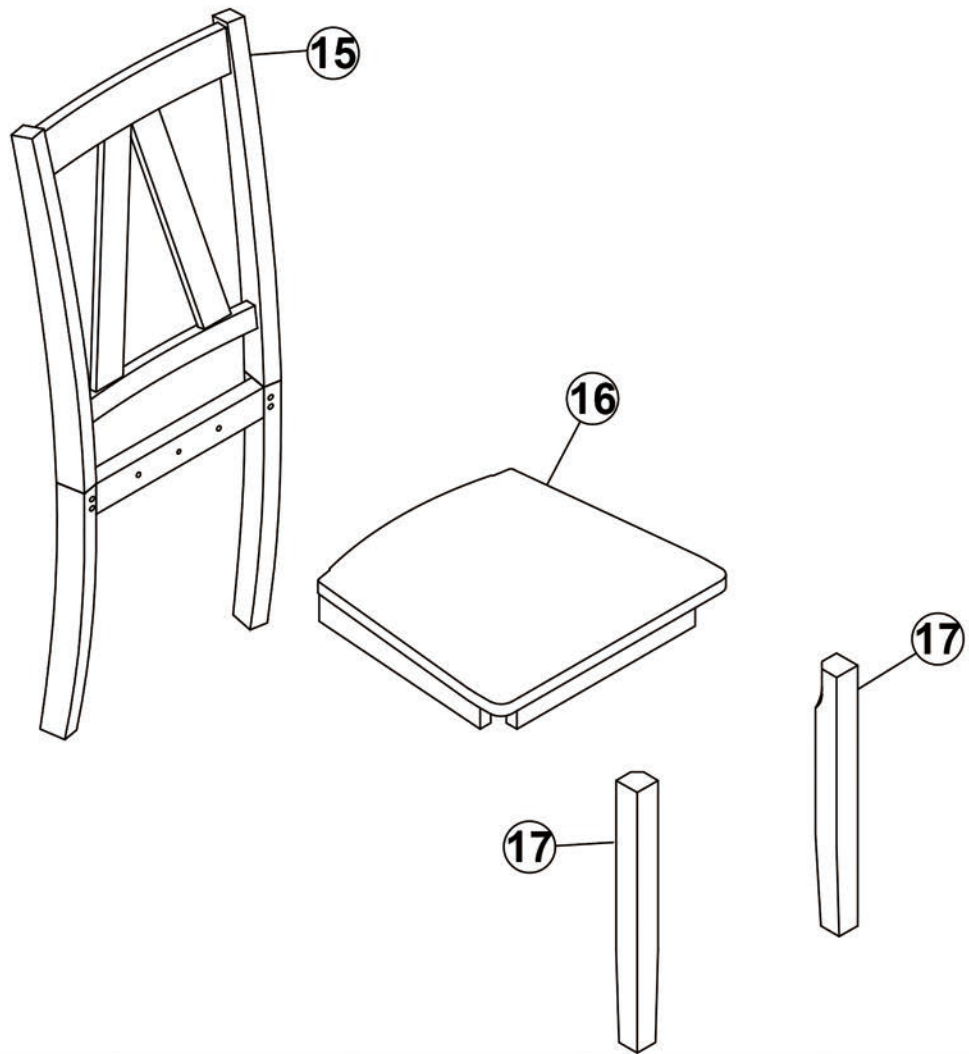

Part List For One Chair

15

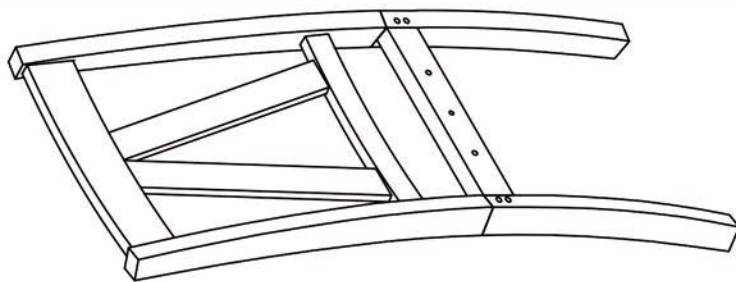

BACK FRAME (1pc)

16

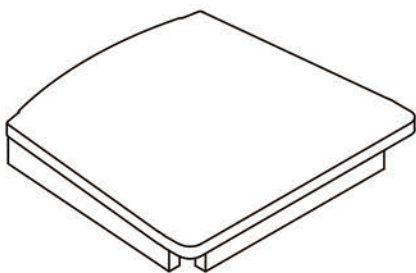







SEAT FRAME (1pc)

17





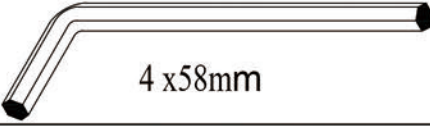

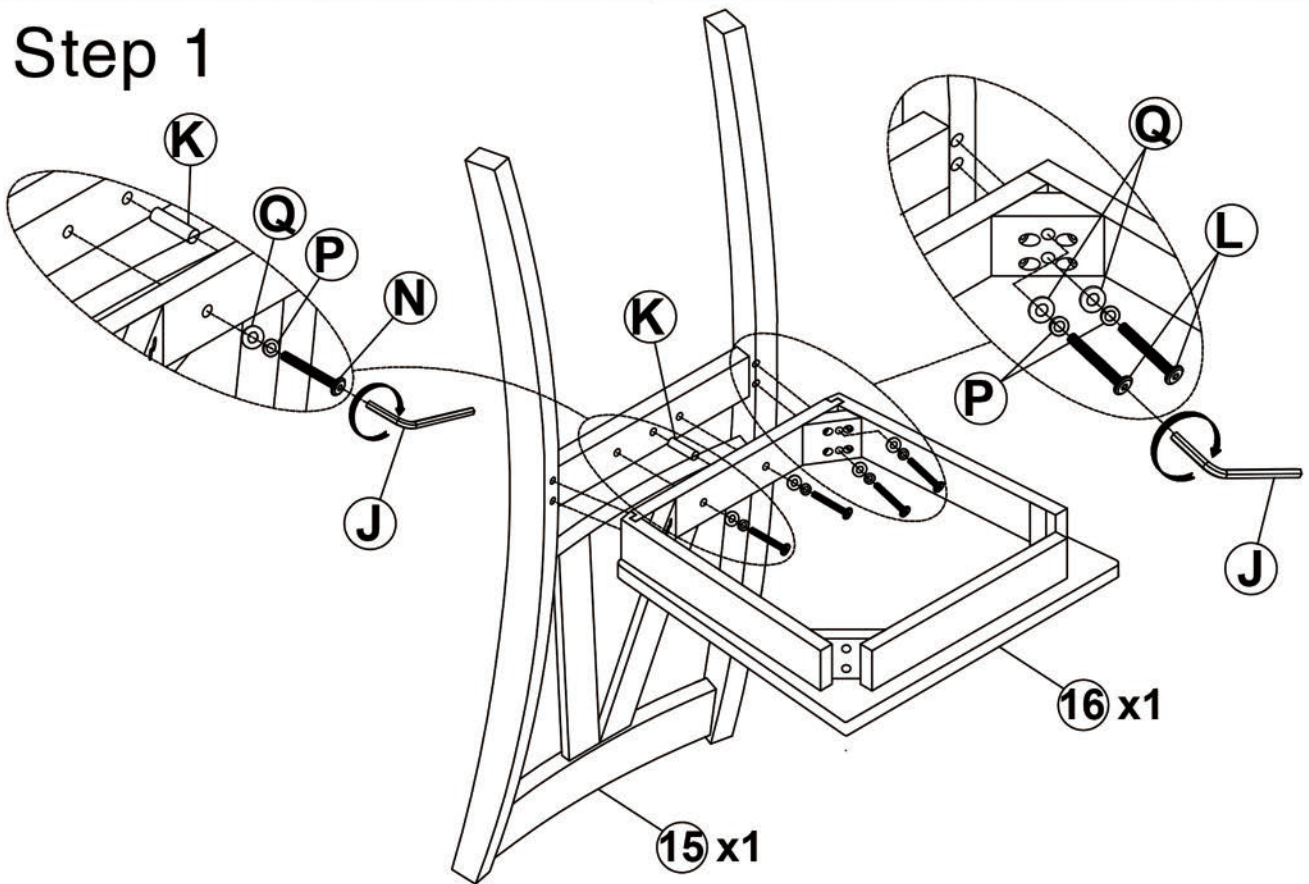

LEGS CHAIR (2pcs)

Hardware List For One Chair

K	 Ø10 x 30mm	P	 Ø1/4" x 13mm
WOODEN PEGS (1pc)		SPRING WASHER (10pcs)	
L	 Ø1/4" x 75mm	Q	 Ø1/4" x 19mm
BOLT (4pcs)		FLAT WASHER (10pcs)	
M	 Ø1/4" x 55mm	J	 4 x 58mm
BOLT (4pcs)		ALLENKEY (1pc)	
N	 Ø1/4" x 35mm		
BOLT (2pcs)			





Step 1

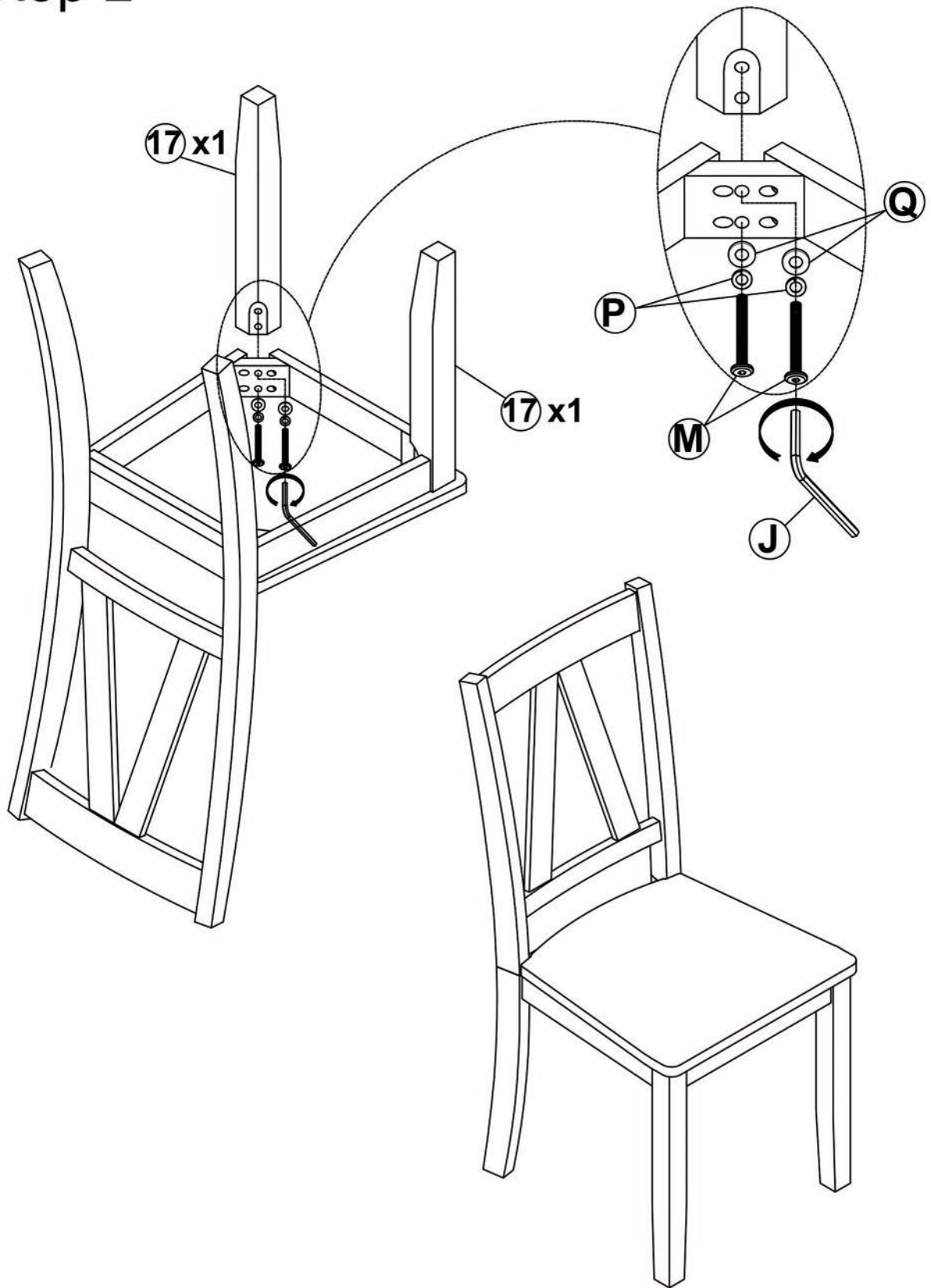

K	Ø10x30		1PC	P	Ø1/4"x13		6PCS
L	1/4x75		4PCS	Q	Ø1/4"x19		6PCS
N	1/4x35		2PCS	J	4x58		1PC

Step 2



M	1/4x55		4PCS	Q	Ø1/4"x19		4PCS
P	Ø1/4"x13		4PCS	J	4x58		1PC