

DE

Montageanleitung

GB USA

Assembly instructions

FR

Notice de montage

IT

Istruzione di montaggio

NL

Handleiding voor de montage

PL

Instrukcja montażu

CZ

Montážní návod

SK

Návod na montáž

HU

Szerelési útmutató

RO

Instrucțiuni de montaj

TR

Montaj talimatı

RU

Инструкция по монтажу

PT

Instruções de montagem

ES

Instrucciones de montaje

AR

تعليمات التجميع

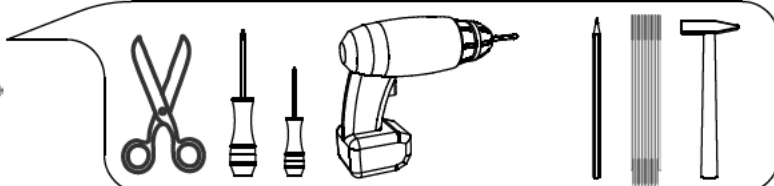
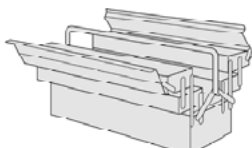
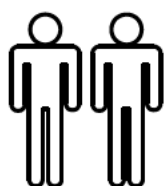

IT**Avvisi di sicurezza**

Durante il montaggio del mobile, il triangolo segnala i seguenti avvisi.

**8**

Non superare i limiti di carico suggeriti, per evitare il danneggiamento del mobile.

9

Non urtare le superfici o bordi di vetro.

12

Tenere lontano dai bambini pezzi di ferramenta come viti, copriviti ecc. per evitare un eventuale soffocamento.

13

Seguire scrupolosamente lo schema di montaggio.

14

Prima della foratura posizionare una tavoletta sotto il pezzo per garantire un foro pulito.

19

Il montaggio deve essere effettuato da persolane qualificato. Se non viene effettuato correttamente, il prodotto può ribaltarsi o cadere, danneggiando persone o cose. Poiché ci sono pareti di materiali diversi, le viti per il fissaggio alla parete non sono incluse. Per scegliere gli accessori di fissaggio adatti, rivolgiti a un rivenditore locale.

DE**Sicherheitshinweise**

Das Dreieck erinnert Sie während der Montage an die folgenden Hinweise.

**8**

Überschreiten Sie nicht die angegebenen Maximalbelastungen. Andernfalls kann das Möbelstück beschädigt oder zerstört werden.

9

Stoßen Sie nicht mit harten Gegenständen an die Glasflächen oder Glaskanten.

12

Achten Sie darauf, daß Kinder keine Kleinteile, wie z. B. Muttern, Abdeckkappen oder Ähnliches in den Mund nehmen. Sie könnten sie verschlucken und daran ersticken.

13

Gehen Sie bei der Montage des Artikels sorgfältig vor und halten Sie sich an die Montageanleitung.

14

Legen Sie ein Holzstück unter das zu durchbohrende Teil, um Holzausriße am Bohrloch zu vermeiden.

19

Fachkundige Montage erforderlich. Unsachgemäße Montage kann zu Unfällen führen. Da es viele verschiedene Wandmaterialien gibt, sind Schrauben für die Wandbefestigung nicht beigegeben. Ggf. sollte man sich beim Eisenwarenfachhandel nach geeignetem Befestigungsmaterial erkundigen.

UK**USA****Safety instructions**

The triangle reminds you during the installation of the following notes.

**8**

Do not exceed the maximum loads specified. Otherwise, the furniture may sustain damage or be irreparably damaged.

9

Do not bump glass surfaces or edges with hard objects.

12

Ensure that children do not put any small parts such as nuts, caps or the like in their mouth. They could swallow and choke on them.

13

When assembling the product, please proceed with caution and comply with the assembly instructions.

14

Before drilling place a slab under the piece to ensure a clean hole.

19

Assembly should be carried out by a qualified person, because wrong assembly may lead to that the furniture will topple over and cause injury or damage. As wall materials vary, screws for fixing to wall are not included. For advice on suitable screw systems, contact your local specialised dealer.

RU**Правила техники безопасности**

Во время монтажа треугольник служит напоминанием для следующих указаний.

**8**

Не допускается превышение указанных максимальных нагрузок. В противном случае возможно повреждение или разрушение мебели.

9

Не допускайте ударов твердыми предметами по стеклянным поверхностям или по их краям.

12

Следите, чтобы мелкие детали, например гайки, крышки и т. п., не попали в рот ребенка. Дети могут их проглотить и задохнуться.

13

При монтаже изделия будьте внимательны и соблюдайте инструкции по монтажу.

14

Положите брусок под деталь, в которой следует сделать отверстие, чтобы избежать разрывистой поверхности вокруг отверстия

19

Монтажът трябва да бъде извършен от специалист, тъй като неправилният монтаж може да доведе до прекатурване и да причини нараняване или повреда. Поради разнообразието от стени материали винтовете за прикрепяне към стената не са осигурени. Свържете се със специализиран доставчик за съвет относно подходящи прикрепващи механизми.

CZ Bezpečnostní pokyny

Trojúhelník vám během montáže připomene následující pokyny.



8

Nepřekračujte uvedená maximální zatížení. V opačném případě může dojít k poškození nebo zničení nábytku.

9

Nenarážejte tvrdými předměty do skleněných ploch nebo hran.

12

Dbejte na to, aby děti nedávaly do úst žádné drobné díly jako např. matice, krytky a podobně. Mohly by je spolknout a udusit se.

13

Při montáži výrobku postupujte pečlivě a dodržujte pokyny uvedené v montážním návodu.

14

Vložte kus dřeva pod části, kde vrtáte, aby se zabránilo trhlinám ve dřevě v místě vrtání.

19

Montáž by měla být provedena kvalifikovanou osobou - nesprávné provedení může vést k převrnutí nábytku a způsobit úraz nebo destrukci. Pro různé dřevní materiály nejsou šroubky a uchycení obsaženy v balení. O vhodném připevnění se poraďte s odborným prodejcem.

TR Güvenlik uyarıları

Durante a montagem do móvel, o triângulo indica as seguintes advertências.



8

Belirtilen azami yük değerini aşmayınız, aksi takdirde mobilya parçası zarar görebilir veya kullanılamaz hale gelebilir.

9

Cam yüzeylere veya cam kenarlara sert cisimlerle temas etmemeye dikkat ediniz.

12

Çocukların somun, muhafaza kapakçıkları ve benzeri küçük parçaları ağızlarına almamalarına dikkat ediniz. Bunları yutabilirler ve boğulabilirler.

13

Montaj esnasında büyük bir itinayla çalışınız, ürünle dikkatlice çalışınız ve mutlaka montaj talimatına uyunuz.

14

Delikte ahşap çatlaklarını önlemek için delinecek parçanın altında bir tahta koyunuz.

19

Montaj, yetkili bir kişi tarafından yapılmalıdır. Yanlış montaj mobilyanın düşmesine ve yaralanma veya hasara yol açabilir. Duvar yapı malzemeleri farklılık göstereceğinden duvar montajı vidaları dahil değildir. Uygun bir vida sistemi için ilgili araç-gerçeri satan dükkanlara başvurunuz.

FR Avis de sécurité

Ces avis vous seront rappelés durant le montage par ce triangle.



8

Ne pas dépasser la charge maximum indiquée cela endommagerait irrémédiablement votre meuble.

9

Veillez à ne pas heurter avec des objets durs les surfaces et le bords des parties en verre.

12

Tenir éloignés les enfants pour éviter qu'ils ne mettent pas de petites pièces dans leur bouche, ils pourraient les avaler et étouffer.

13

Durant le montage de votre meuble veuillez procéder avec prudence et respecter les instructions de montage.

14

Pour percer sans endommager les surfaces utilisez une contre partie en bois que vous placez sous la pièce à percer.

19

Le montage doit être effectué par une personne compétente. Un montage mal effectué peut provoquer la chute du meuble et blesser quelqu'un. Les vis et ferrures pour fixer le meuble au mur ne sont pas incluses. Choisissez des vis et ferrures adaptées au matériau de votre mur. En cas de doute, demandez conseil à un vendeur spécialisé.

SK Bezpečnostné pokyny

Trojuholník vám počas montáže pripomenie nasledujúce pokyny.



8

Neprekročte uvedené maximálne zaťaženia. V opačnom prípade sa môže nábytok poškodiť alebo zničiť.

9

Nenarazte s tvrdými predmetmi na sklenené plochy alebo hrany.

12

Dbejte, aby si deti nemohli dať do úst drobné diely, ako napr. matice, krytky alebo podobne. Mohli by ich prehltnúť a zadusiť sa.

13

Pri montáži výrobku postupujte obozretne a dodržujte návod na montáž.

14

Vložte kus dreva pod časti, kde vrtáte, aby sa zabránilo trhlinám v dreve v mieste vrtania.

19

Pohišťvo naj sestavíja za to usposobljena oseba, saj se lahko nepravilno sestavljeno pohišťvo prevrne in povzroči telesne poškodbe ali materialno škodo. Ker se stenski materiali razlikujejo, vijaki niso priloženi. Za nasvet glede primerne vrste vijakov se obrnite na najbližjo specializirano trgovino.

NL**Veiligheidsinstructies**

De driehoek herinnert u tijdens de installatie van de volgende meldingen.

**8**

Overschrijd de aangegeven maximale belastingen niet. Anders kan het meubelstuk worden beschadigd of vernield.

9

Stoot niet met harde voorwerpen tegen de glazen oppervlakken of randen.

12

Zorg ervoor dat kinderen geen kleine stukken, zoals moeren, afdekkapjes of dergelijke in de mond nemen. Ze kunnen ze inslikken en daardoor stikken.

13

Ga bij de montage van het artikel zorgvuldig te werk en houd u aan de handleiding voor de montage.

14

Leg een stuk hout onder het onderdeel waarin een gat moet worden geboord, zodat barsten in het hout aan het geboorde gat worden vermeden.

19

De montage dient te worden uitgevoerd door een vakbekwaam iemand. Foutieve montage kan ertoe leiden dat het meubel omvalt, waardoor er persoonlijk letsel of schade kan ontstaan. Omdat er veel verschillende wandmaterialen bestaan, zit er geen wandbeslag bijgesloten. Voor advies over geschikt wandbeslag, neem contact op met de vakhandel.

PL**Wskazówki bezpieczeństwa**

Trójkąt przypomina o następujących wskazówkach dotyczących montażu.

**8**

Nie wolno przekraczać podanych maksymalnych wartości obciążenia. W przeciwnym razie mebel może zostać uszkodzony lub zniszczony.

9

Nie uderzać twardymi przedmiotami w szklane powierzchnie i krawędzie.

12

Należy dopilnować, aby dzieci nie bawiły się lub też brały do ust żadnych drobnych części mebla, takich jak np. nakrętki, zatyczki itp.. Mogłyby je połknąć i udusić się nimi.

13

Podczas montażu proszę postępować z należytą uwagą i zgodnie z instrukcją montażu. Artykuł może być montowany tylko przez osoby z odpowiednimi kwalifikacjami.

14

Podłożyć pod przewiercaną część kawałek drewna, aby zapobiec ewentualnym pęknięciom wokół wierconej dziury.

19

Montaż powinien być przeprowadzany przez wykwalifikowaną osobę, ponieważ złe zmontowanie może spowodować zniszczenie mebla lub może wyrządzić szkodę domownikom. Ponieważ w każdym pomieszczeniu ściany mogą być wykonane z innego materiału, komplet nie zawiera żadnych wkrętów ani umocowań. Aby zasięgnąć porady w kwestii wyboru odpowiednich wkrętów skontaktuj się z lokalnym sklepem specjalistycznym.

RO**Instrucțiuni referitoare la siguranță**

Triunghiul vă atenționează să țineți cont în timpul montajului de următoarea indicație

**8**

Nu depășiți solicitările maxime specificate. Altfel puteți să deteriorați sau să distrugeți piesa de mobilier.

9

Evitați impactul suprafețelor sau a marginilor din sticlă cu obiecte dure.

12

Supravegheați copiii pentru că pot să introducă în gură piesele mici, cum ar fi de exemplu piulițe, capace sau altele similare. Ei pot să le înghită și se pot asfixia.

13

Procedați cu atenție la montarea produsului și respectați instrucțiunile de montaj.

14

Introduceți o bucată de lemn dedesubtul elementului de găurit, pentru a evita fisurarea lemnului în dreptul găurii.

19

Se recomandă ca montarea să fie realizată de o persoană calificată; asamblarea greșită poate determina desprinderea mobilierului, deteriorarea lui și chiar producerea de accidente. Întrucât materialele din care sunt construiți pereții variază, șuruburile pentru fixarea pe perete nu sunt incluse. Contactează dealer-ul tău local pentru consiliere.

HU**Biztonságtechnikai**

A háromszög a szerelés közben a következő utasításra emlékezteti.

**8**

Tartsa be az engedélyezett maximális terhelhet séget / teljesítményt. Különben a bútor és annak alkatrészei megsérülhetnek, tönkre mehetnek.

9

Védje az üvegfelületeket és azok éleit az ütődésektől.

12

Gondoskodjon arról, hogy a gyerekek ne vehessék a szájukba a kis alkatrészeket, pl. az anyákat, a fed kúpokat stb. Ezeket lenyelve megfulladhatnak.

13

Atermék összeszereléskor körültekint en járjon el, és tartsa magát a szerelési útmutatóban foglaltakhoz.

14

Fektesse egy fadarabot az átfúrandó rész alá; megelőzve, hogy a furat szélének faanyaga kitöredezzen.

19

Az összeszerelést ajánlatos képzett szakemberre bízni, mert a helytelen összeszerelés következtében a bútor felborulhat és sérülést okozhat. Mivel a fal anyaga lakásonként / otthononként eltérő lehet, a rögzítéshez szükséges csavarokat a csomag nem tartalmazza. A megfelelő csavar kiválasztásáért kérj tanácsot az áruházban a szakképzett személyzettől.

PT**Avisos de segurança**

Durante a montagem do móvel, o triângulo indica as seguintes advertências.

**8**

Não ultrapasse os limites de carga recomendados, para evitar danos no móvel.

9

No golpee las superficies o bordes del cristal .

12

Mantenha longe do alcance das crianças todo o tipo de peças pequenas como parafusos e outras, para evitar o risco de sufocamento.

13

Siga escrupulosamente o esquema de montagem.

14

Antes de la perforación colocar una tableta en la pieza para asegurar un agujero limpio.

19

Montaje a realizar por montador autorizado, pues un montaje erróneo puede resultar en una caída del mueble, causando daños a personas o cosas. Como hay muchas clases de materiales de pared, no se incluyen los tornillos de montaje. Para sugerencias sobre sistemas de colocación adecuados, ponte en contacto con tu especialista más cercano.

ES**Avisos de seguridad**

Durante el montaje del mueble, prestar atención al triángulo que informa sobre los siguientes avisos.

**8**

No exceder los límites de carga aconsejados, para evitar daños al mueble.

9

Não bata as superfícies ou bordas do vidro .

12

Mantener alejado de los niños piezas de herramientas como tornillos, ecc para evitar una eventual asfixia.

13

Seguir escrupulosamente el diagrama de montaje.

14

Antes da perfuração colocar um comprimido em peça para garantir um buraco limpo.

19

A montagem deverá ser realizada por uma pessoa qualificada, porque uma montagem incorrecta pode ocasionar que o móvel caia e cause lesões ou estragos. Como os materiais de parede variam, os parafusos para fixar à parede não estão incluídos. Para obter conselho sobre o sistema de parafusos adequado, consulte o seu retalhista local especializado.

AR**إشعارات الأمان**

من فظلك اتبع الخطوات التالية الموضحة أدناه لكيفية التركيب و المرموز لها بالمثلثات الصفراء أسفله

**8**

رجاء لا تتجاوز الحد الأقصى المسموح للأحمال والأشياء سوف ينجر عن ذلك أضرار يمكن لأن تصل لدرجة التلف أو الكسر

9

لا تعرض الأسطح الزجاجية أو الحواف للصدمات مع الاجسام الصلبة

12

تأكد من ابعاد الأجزاء الصغيرة و المسامير و البراغي التي يمكن ابتلاعها من أيدي الأطفال

13

عند تجميع و تركيب المنتج يرجى اتباع الخطوات المنصوص عليها بدقة و حذر

14

قبل الثقب يرجى وضع لوحة تحت مكان الثقب للحصول لثقوب نظيف و عدم اتلاف الأرضية

19

من الأفضل الاستعانة بشخص مؤهل أو مختص في تركيب الأثاث لأن التركيب الخاطئ قد ينتج عنه السقوط أو التلف أو الكسر و قد يسبب إصابات. كما أن المختص سوف يعرف تماماً نوع المسامير و البراغي المناسبة لأسطحكم والتي قد تكون غير متناسبة مع البراغي و المسامير المرفقة

Service • Dienstverlening • Serwis • Servis • Сервисная служба • Servizio

Name • Naam • Nazwa • Isim • Название • Nom • Nome

Nr. • No. • Номер • Nu.

Тур • Туре • Тір • Тип • Тіро

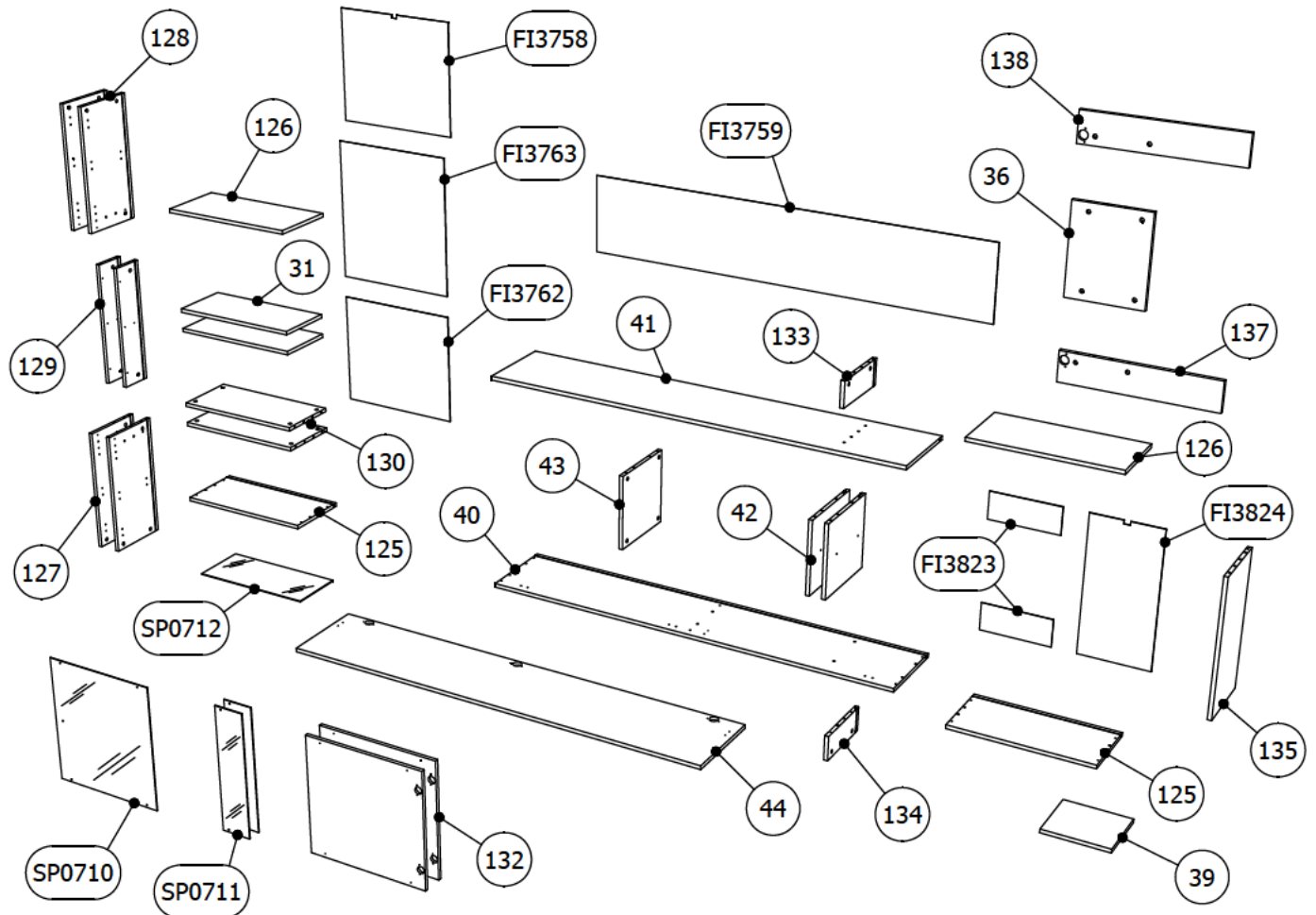
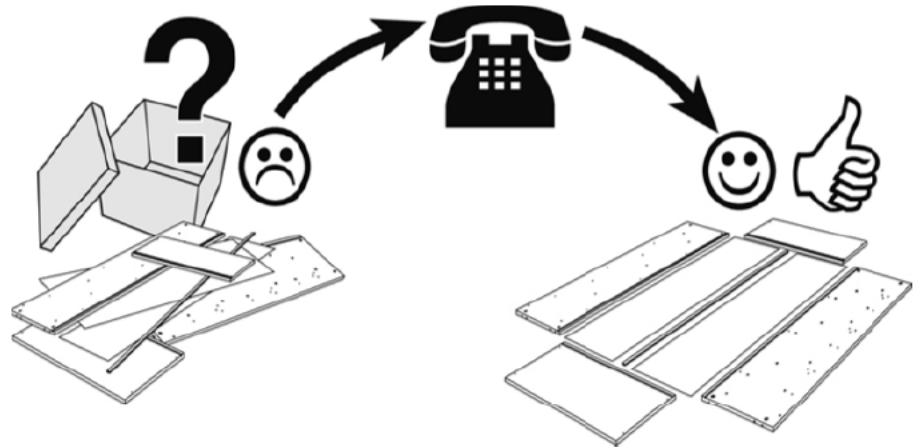

Code	Qt.	Dimensions	Box	Code	Qt.	Dimensions	Box	Code	Qt.	Dimensions	Box
31	2	567 x 250 x 16	2-1	127	2	568 x 283 x 16	2-1	FI3758	1	524 x 581 x 3	2-1
36	1	358x297x16	2-2	128	2	568 x 283 x 16	2-1	FI3759	1	1782x332x3	2-2
39	1	283,5x250x16	2-2	129	2	568 x 142 x 16	2-2	FI3762	1	524 x 581 x 3	2-1
40	1	1800x334x16	2-2	130	2	567 x 263 x 16	2-1	FI3763	1	664 x 581 x 3	2-1
41	1	1800x334x16	2-2	132	2	583 x 597 x 16	2-1	FI3823	2	116 x 290 x 3	2-1
42	2	318x334x16	2-2	133	1	109 x 283 x 16	2-2	FI3824	1	582 x 290 x 3	2-1
43	1	318x314x16	2-2	134	1	109 x 283 x 16	2-2	SP0710	1	563 x 628 x 4	2-1
44	1	1797x348x16	2-2	135	1	568 x 283 x 16	2-2	SP0711	2	628 x 147 x 4	2-1
125	2	600 x 283 x 16	2-1	137	1	120x600x16	2-2	SP0712	1	556 x 246 x 4	2-1
126	2	600 x 283 x 16	2-1	138	1	120x600x16	2-2				

12

10 x FE9392 4x15



48 x SPL001



26 x FE9403 3,5x16



12 x FE2769



36 x FE2429



8 x FE9728 3x25



52 x FE9604



1 x FE9208 3,5x20



4 x FE2529

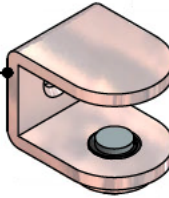

27 x FE9205A



2 x FE9302 4MAx22,5



4 x FE9134 7x50

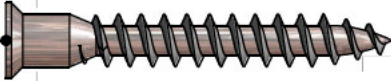

2 x FE9696



8 x FE9729

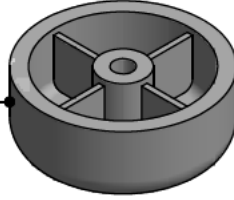

4 x FE9685



8 x FE2279



16 x FE2457

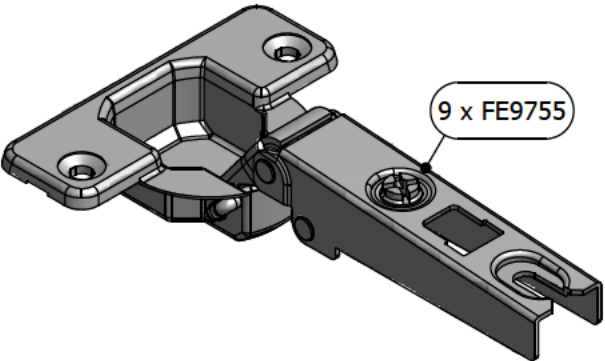

9 x FE9755

4 x FE2515A



9 x FE9455



4 x FE9614

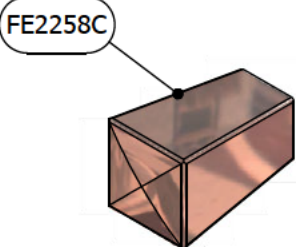

FE2258C

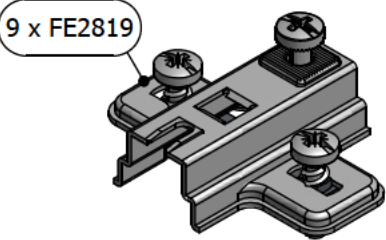

9 x FE2819

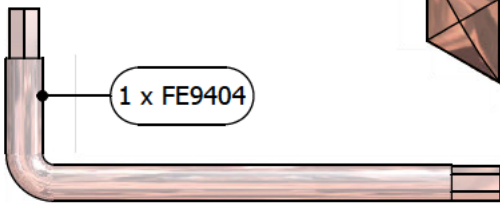

1 x FE9404

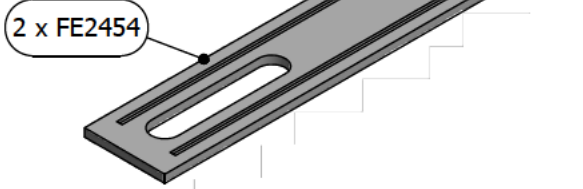

2 x FE2454

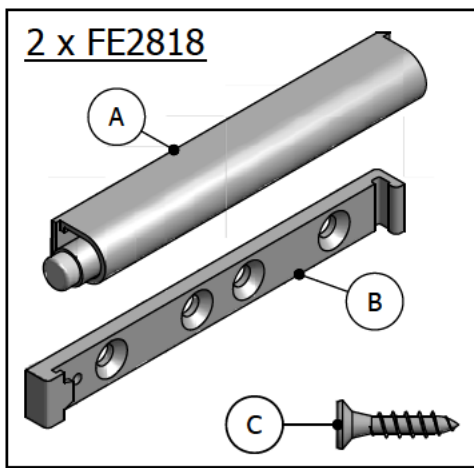

2 x FE2818

A

B

C

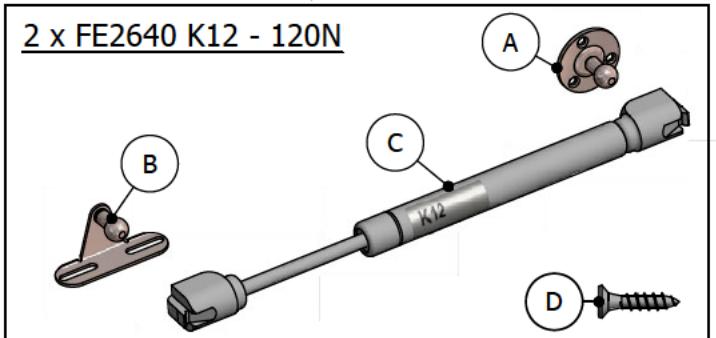

2 x FE2640 K12 - 120N

A

B

C

D

13

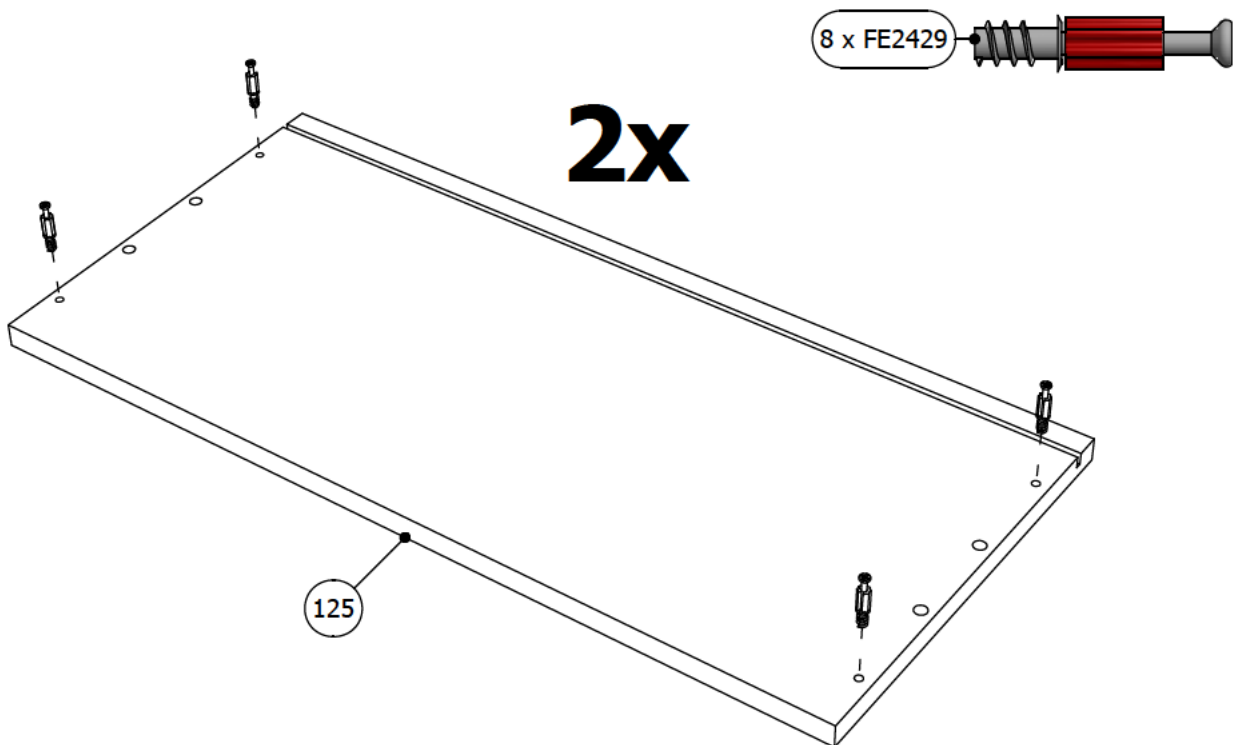
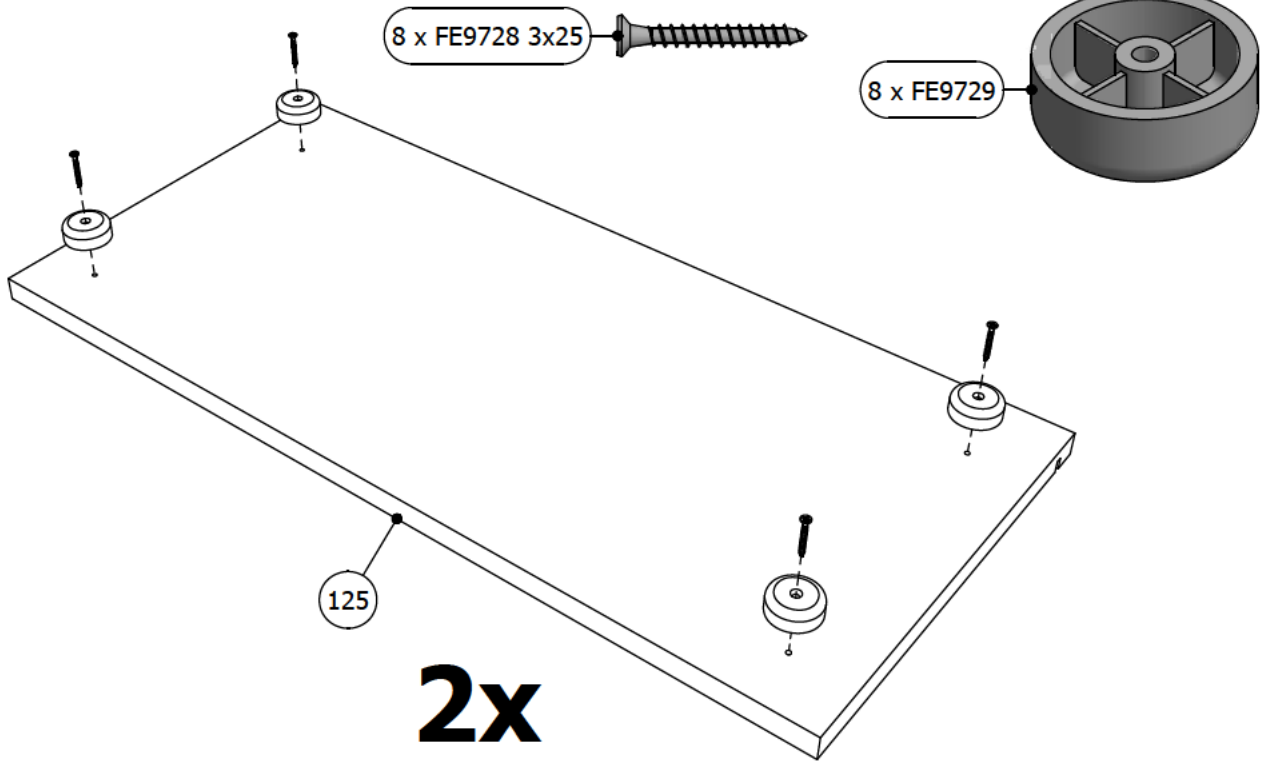
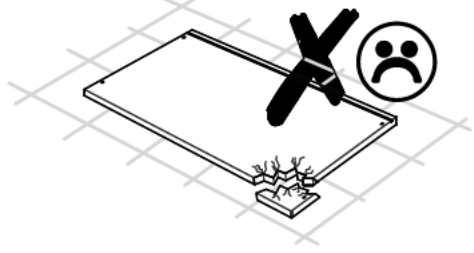
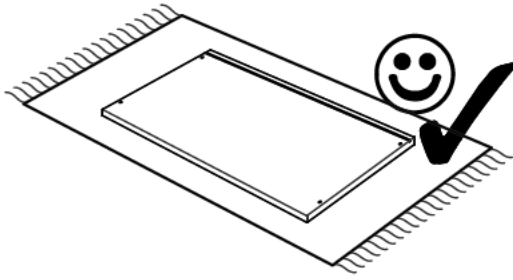

8 x SPL001



2x

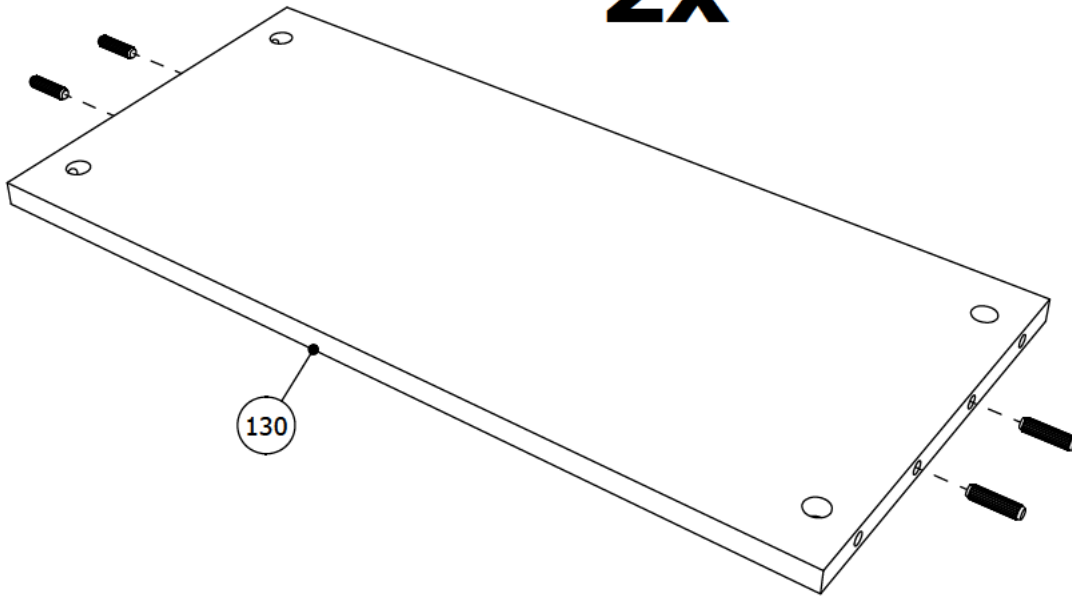

8 x SPL001



8 x FE2429



2x

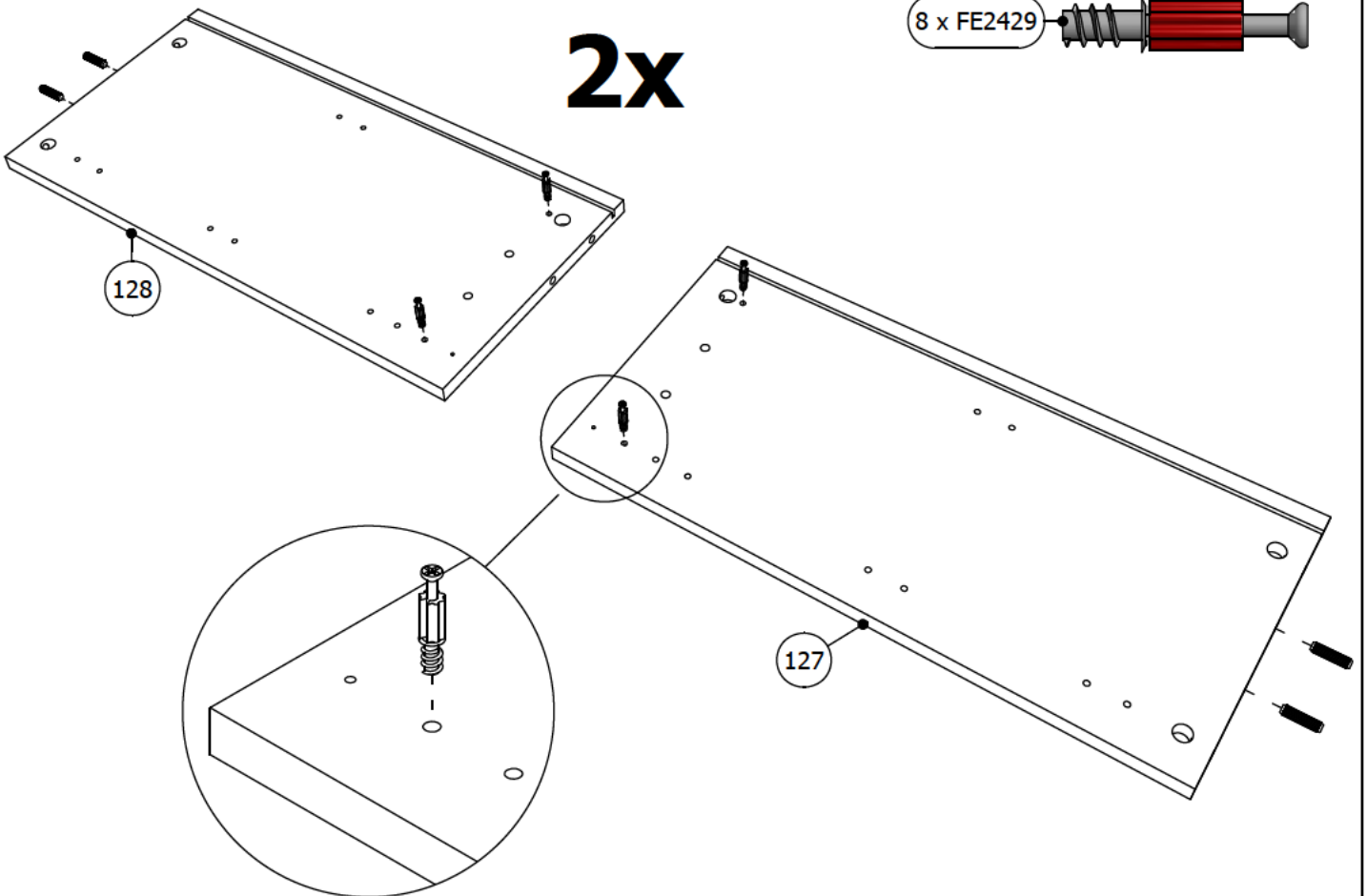

4 x FE9604



4 x FE2279



4 x FE2529

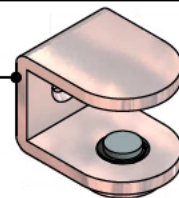

4 x FE9403 3,5x16



4 x SPL001

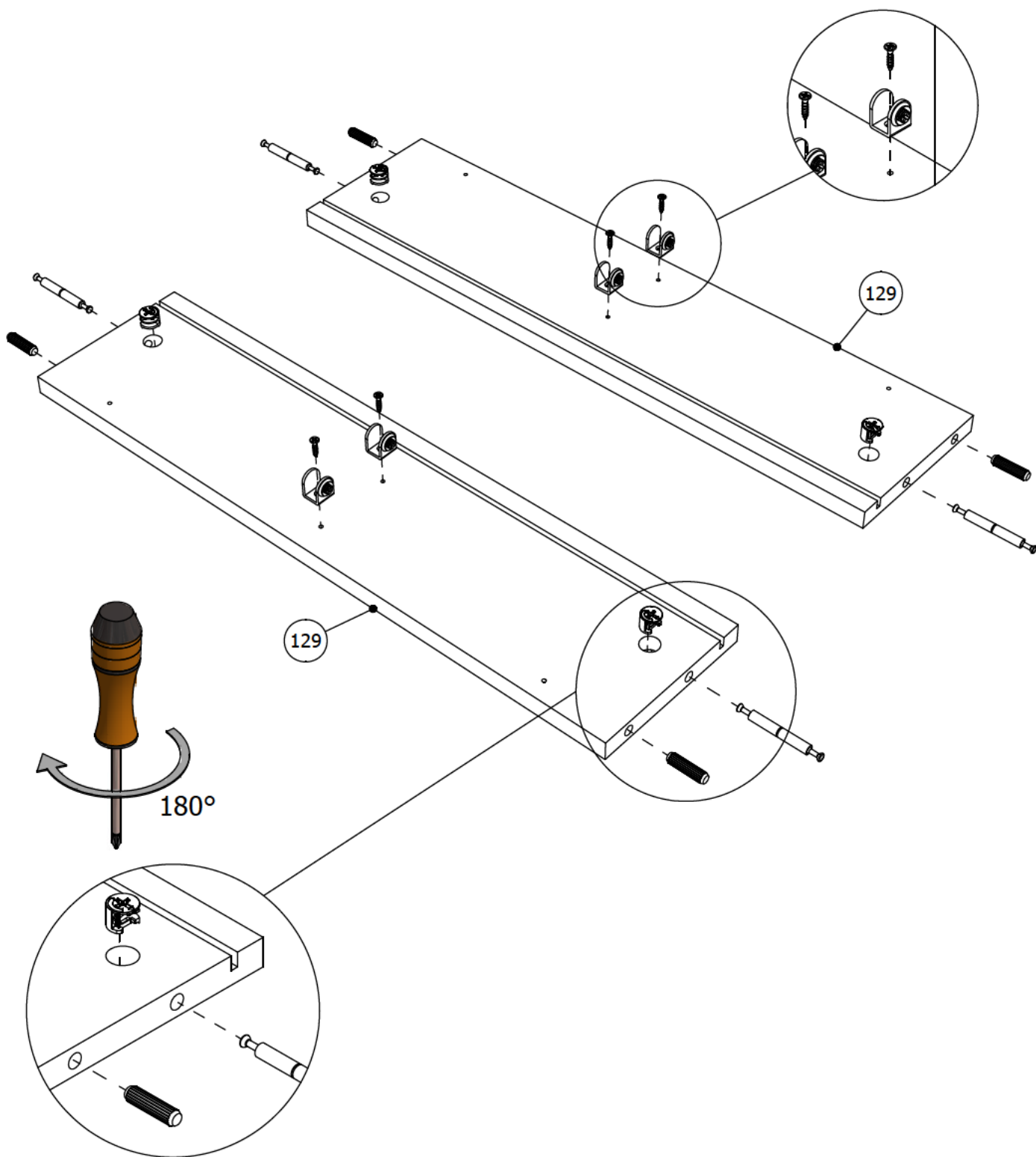

8 x FE2457

4 x FE9604

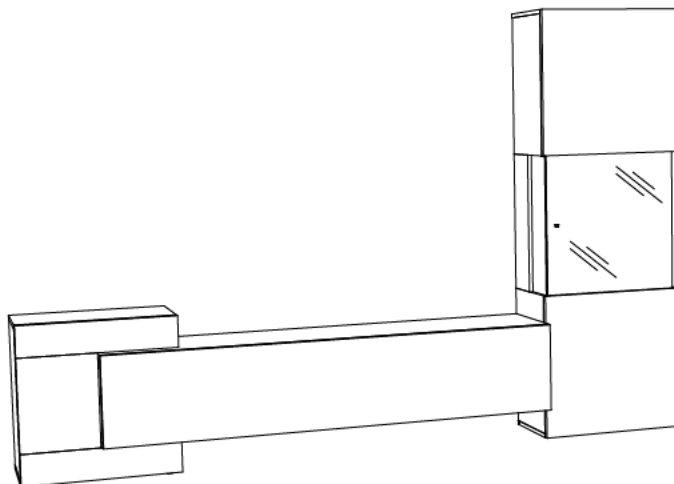
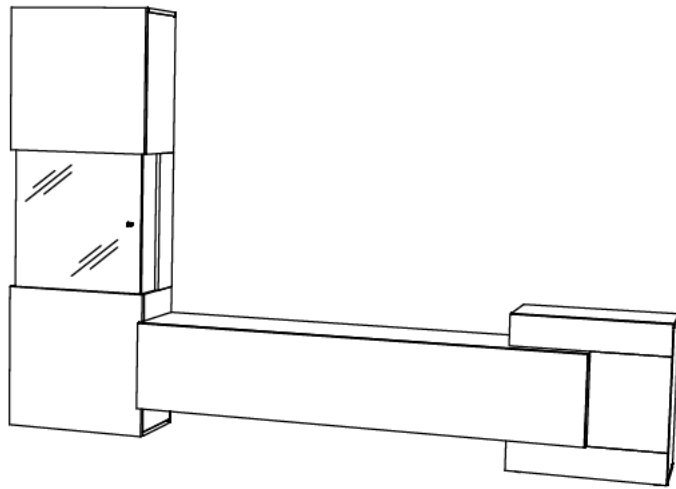
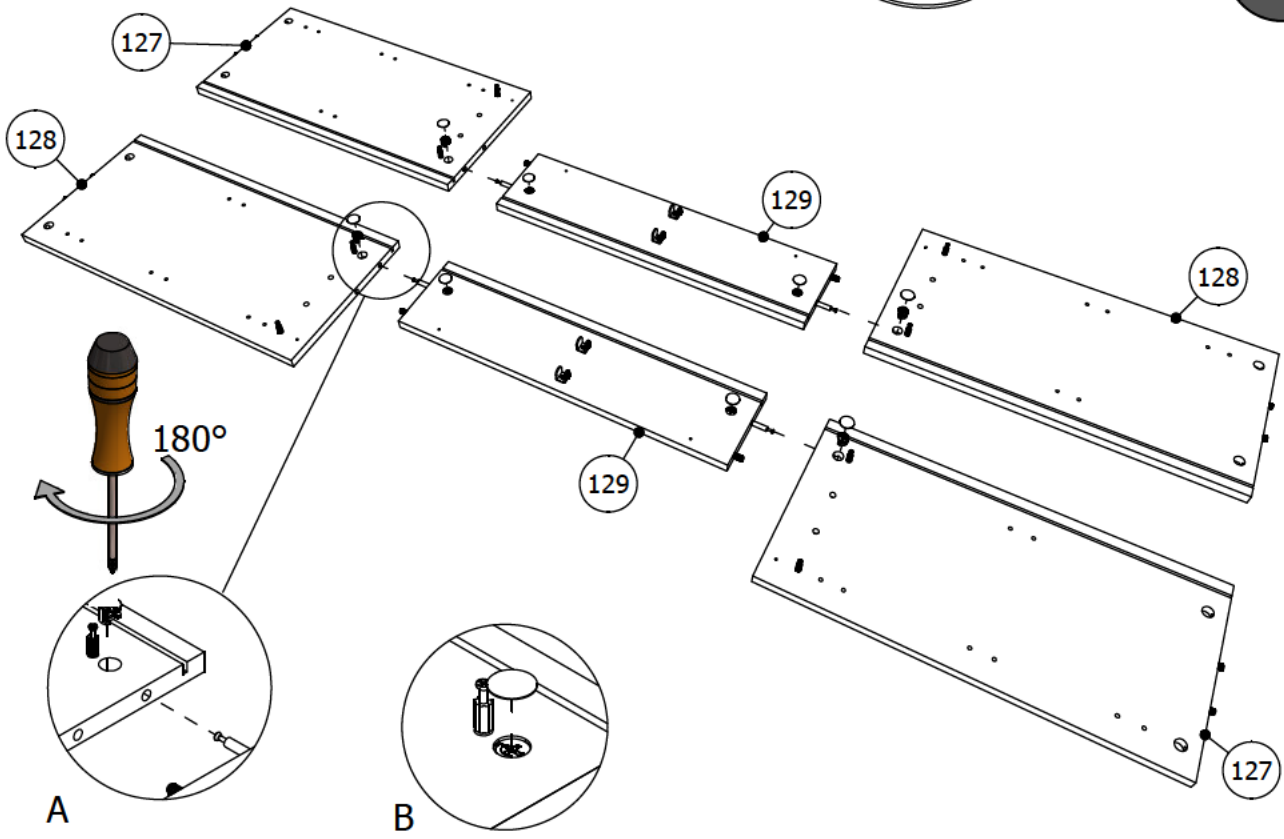

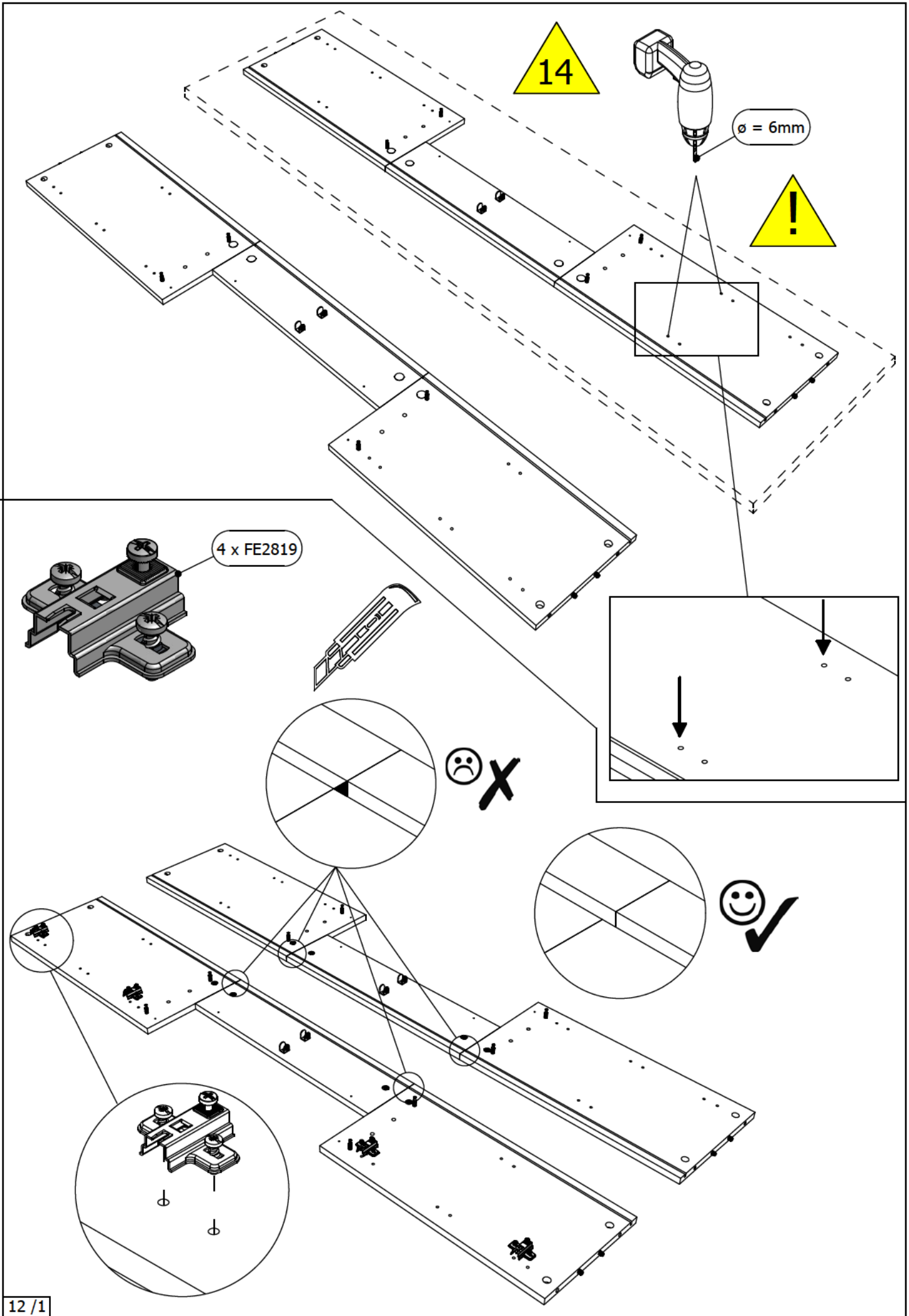

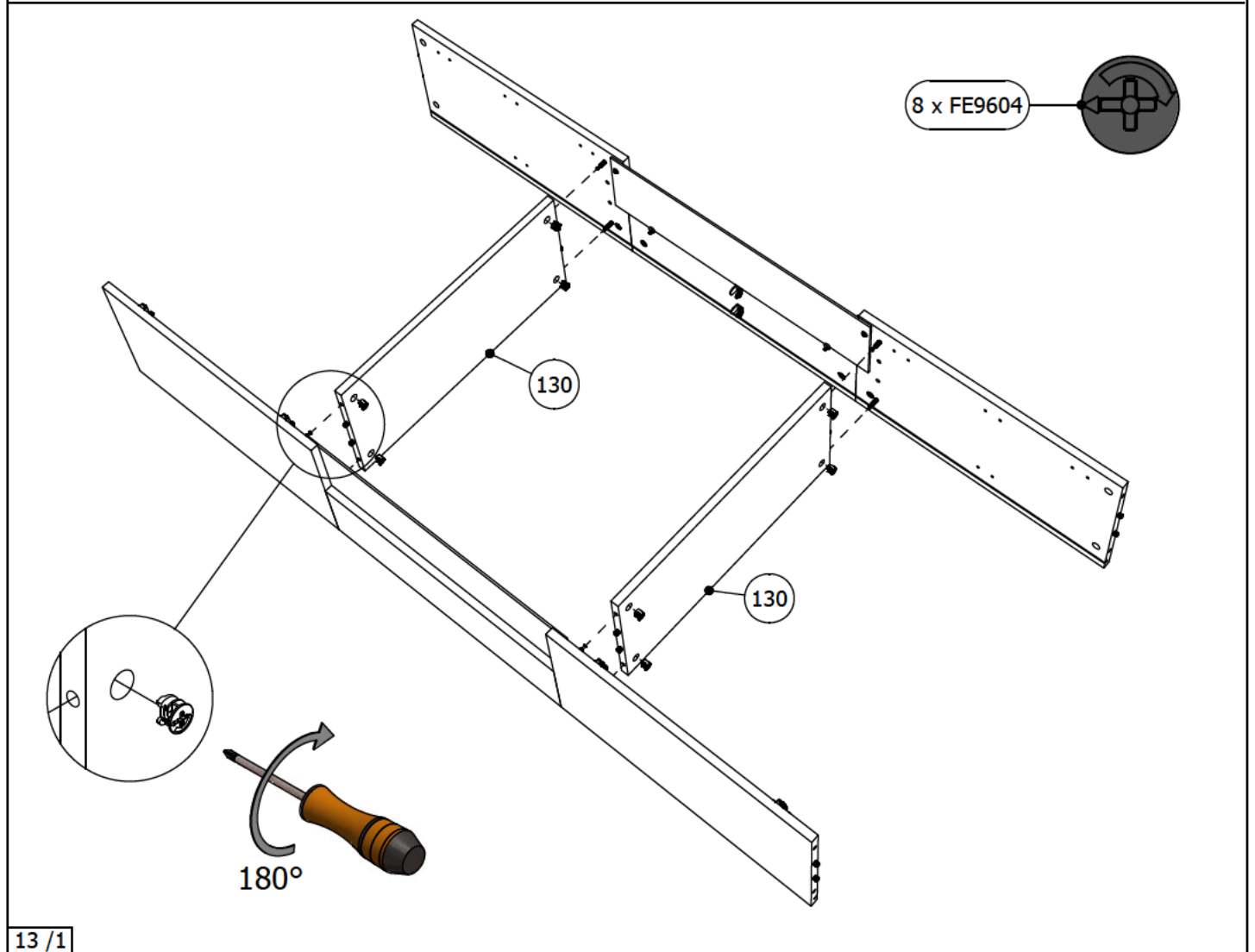
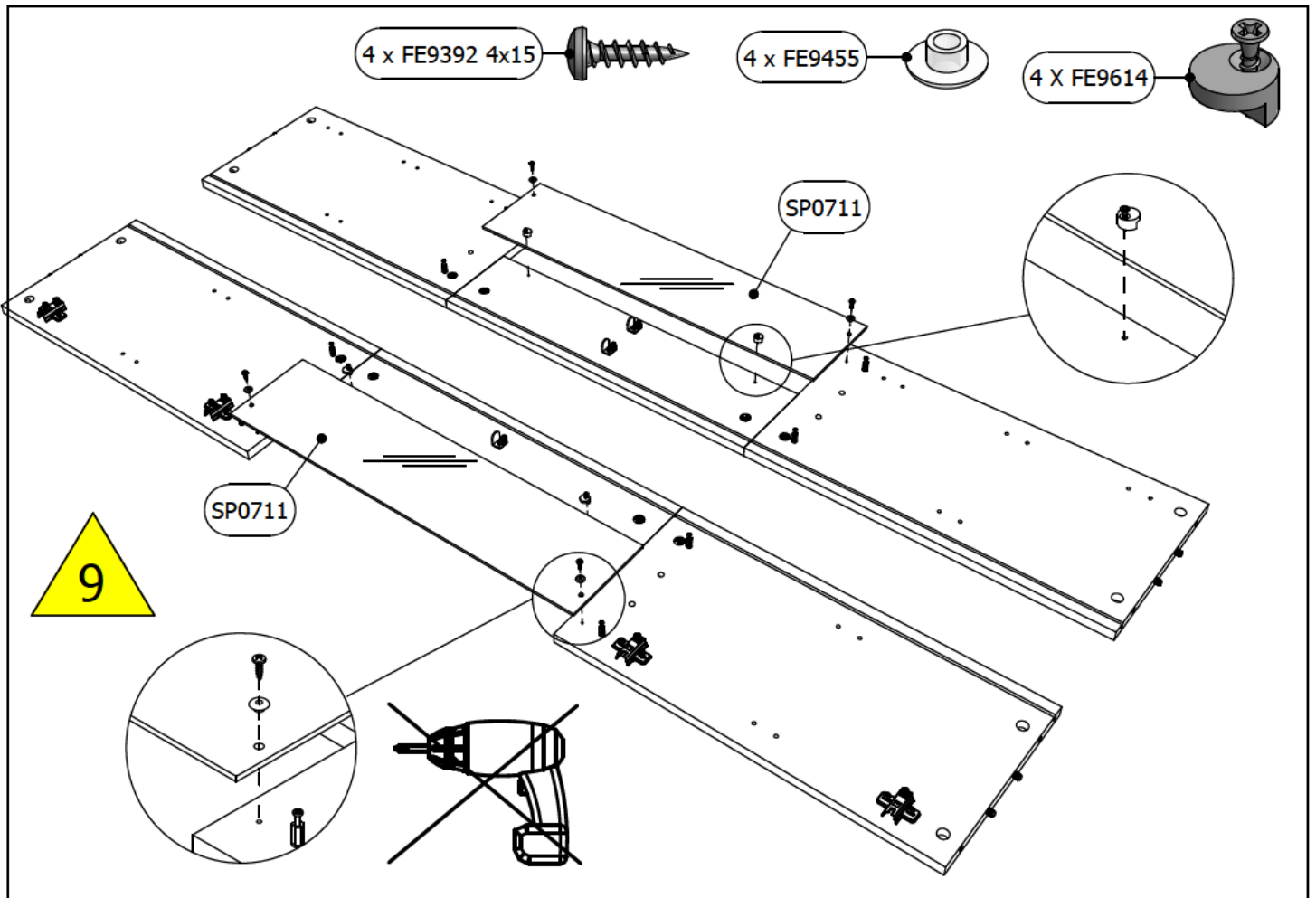

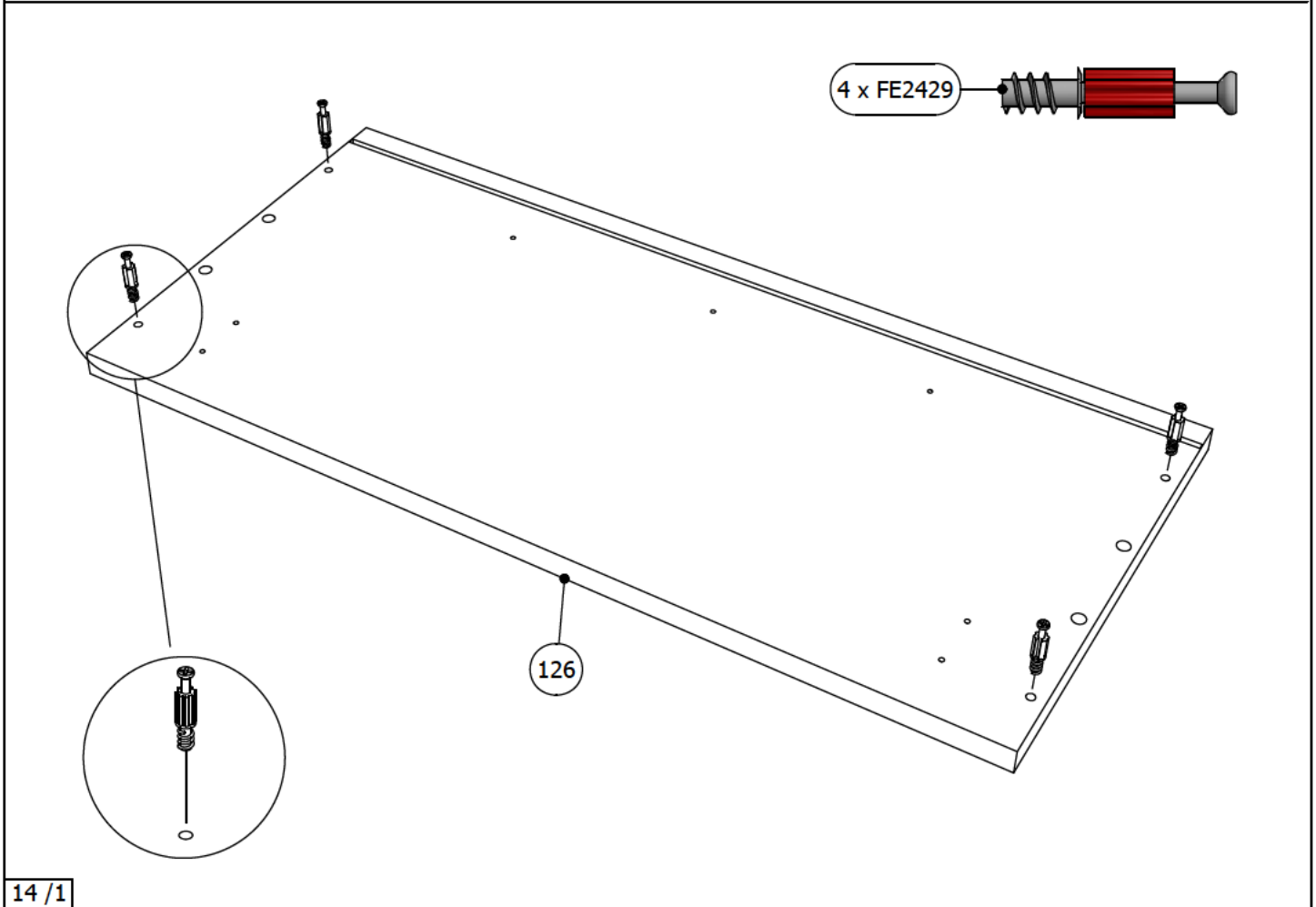
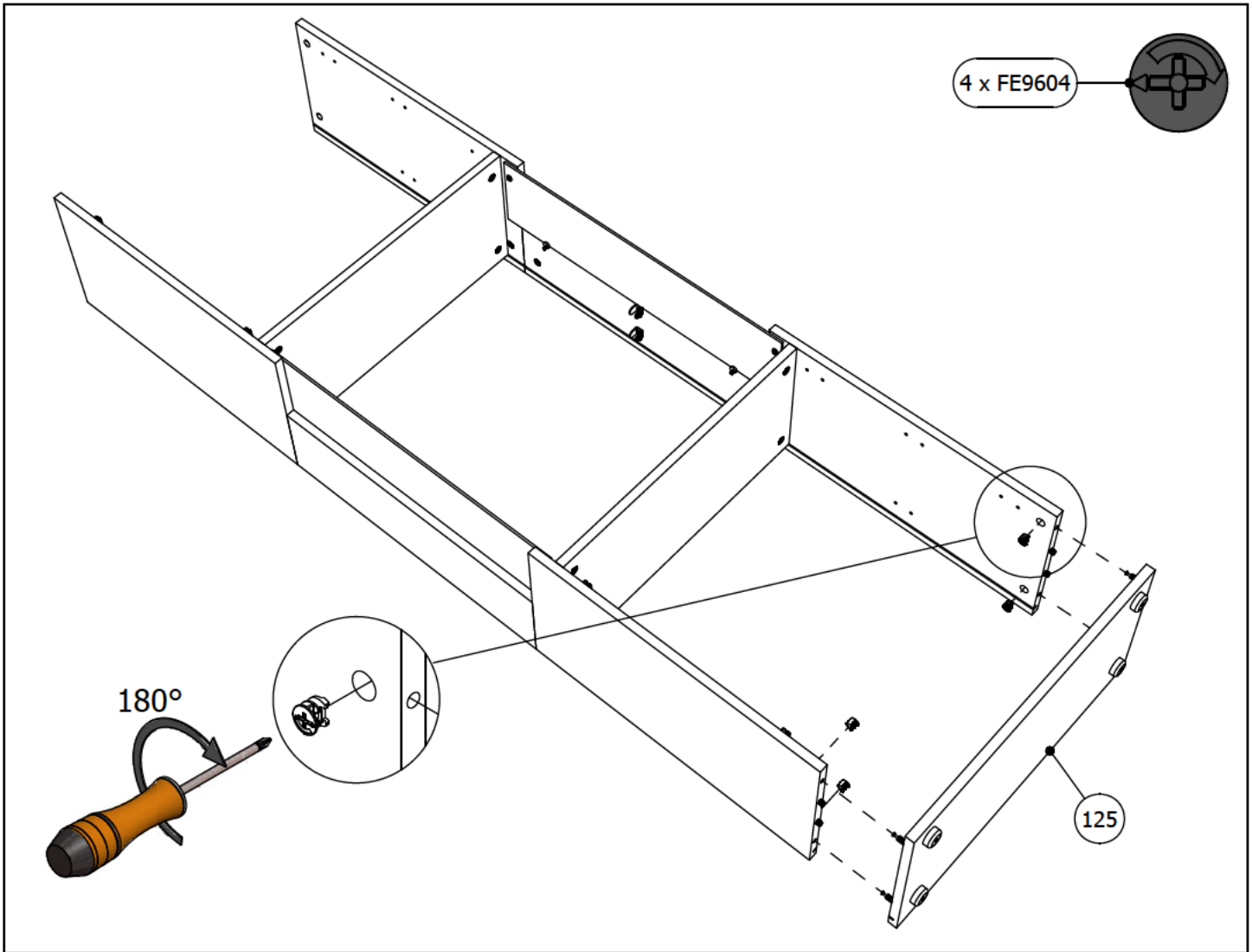

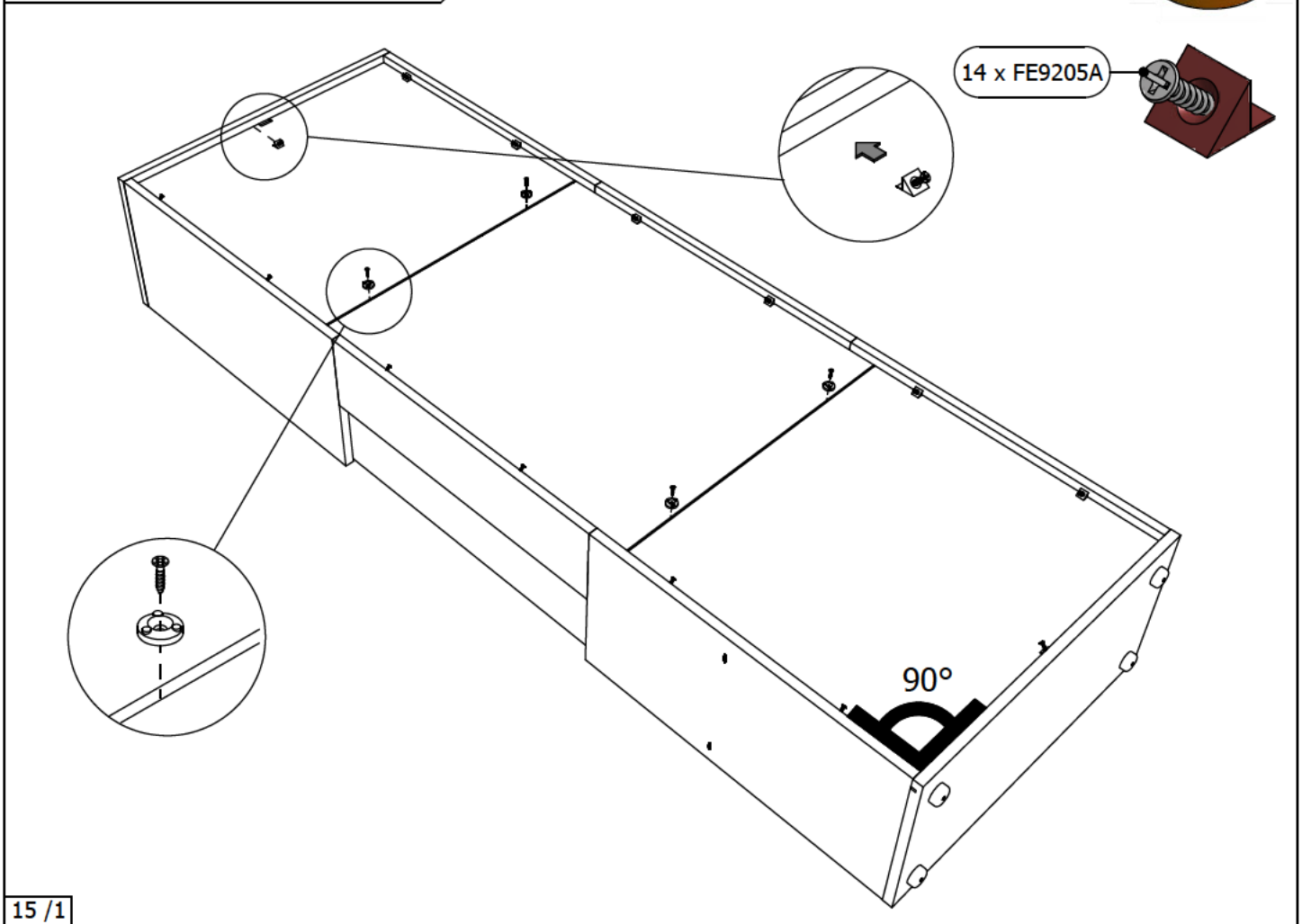
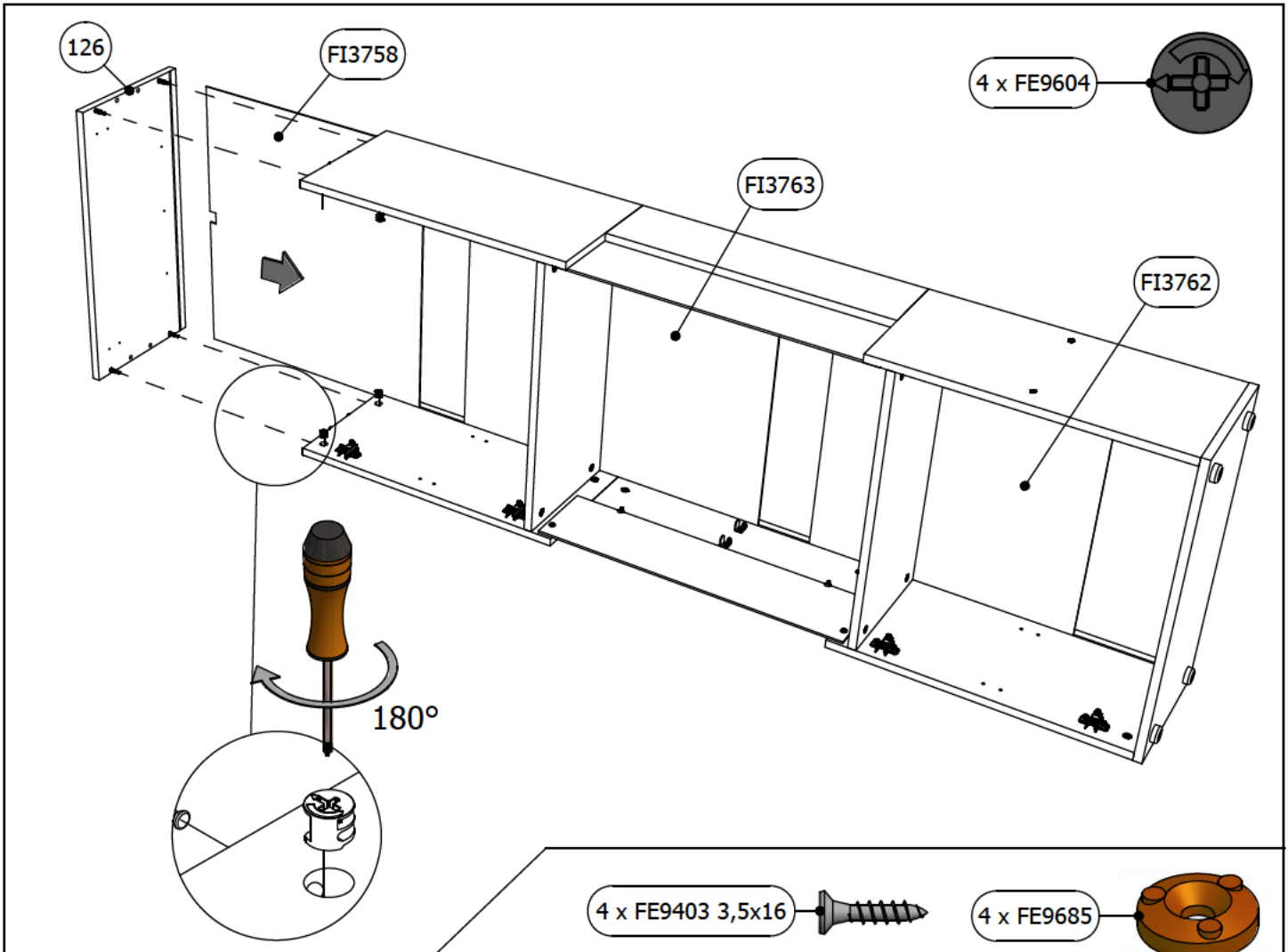

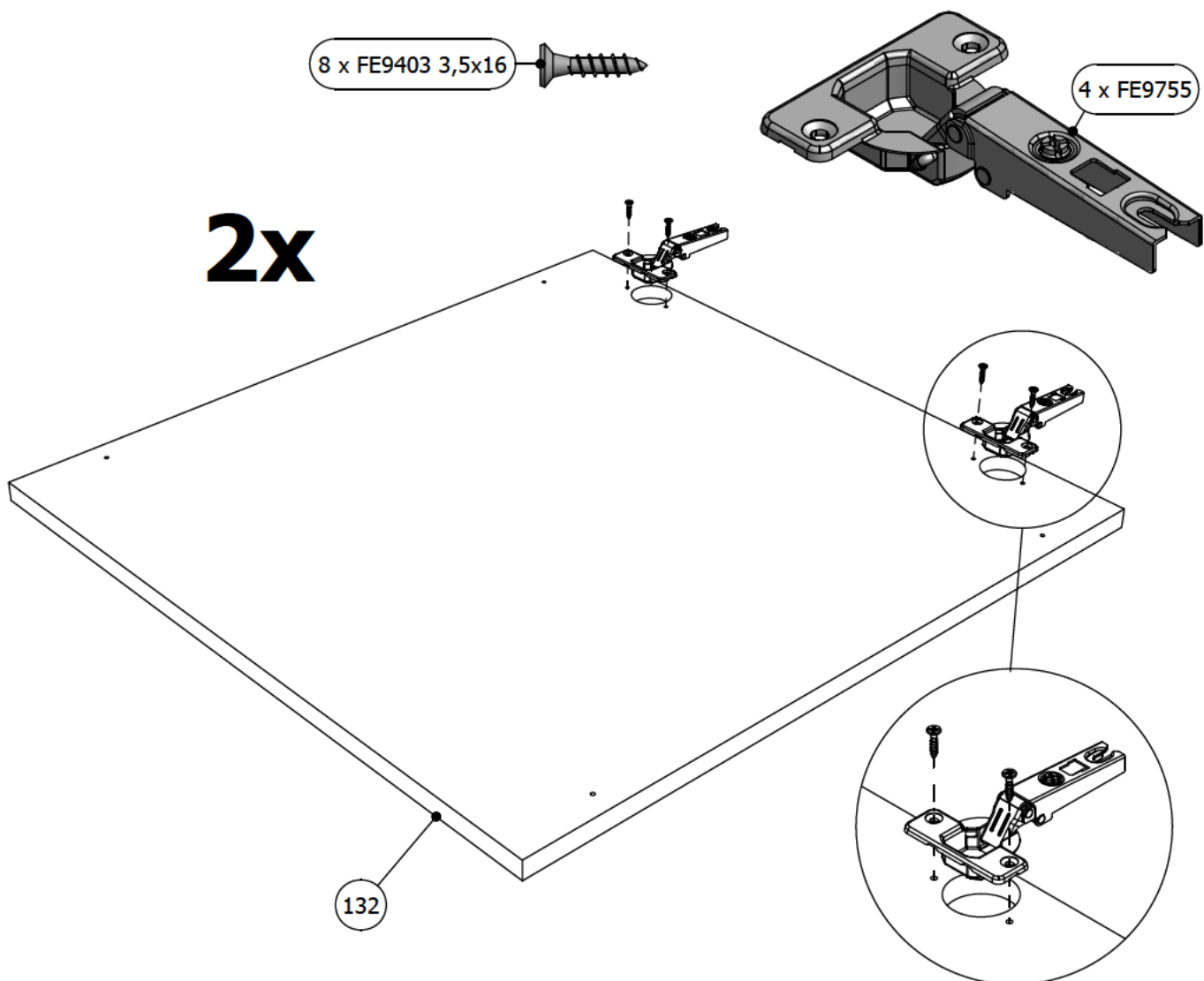
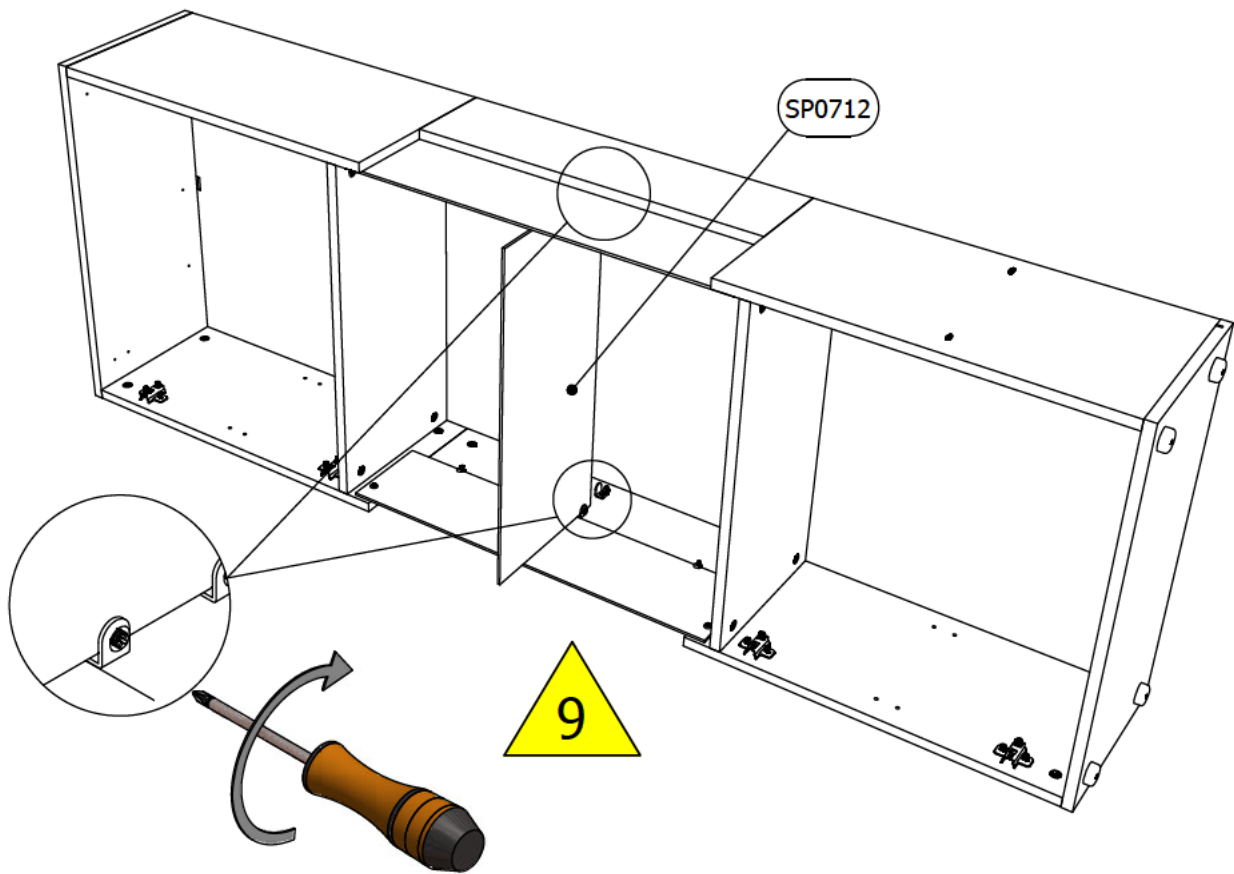

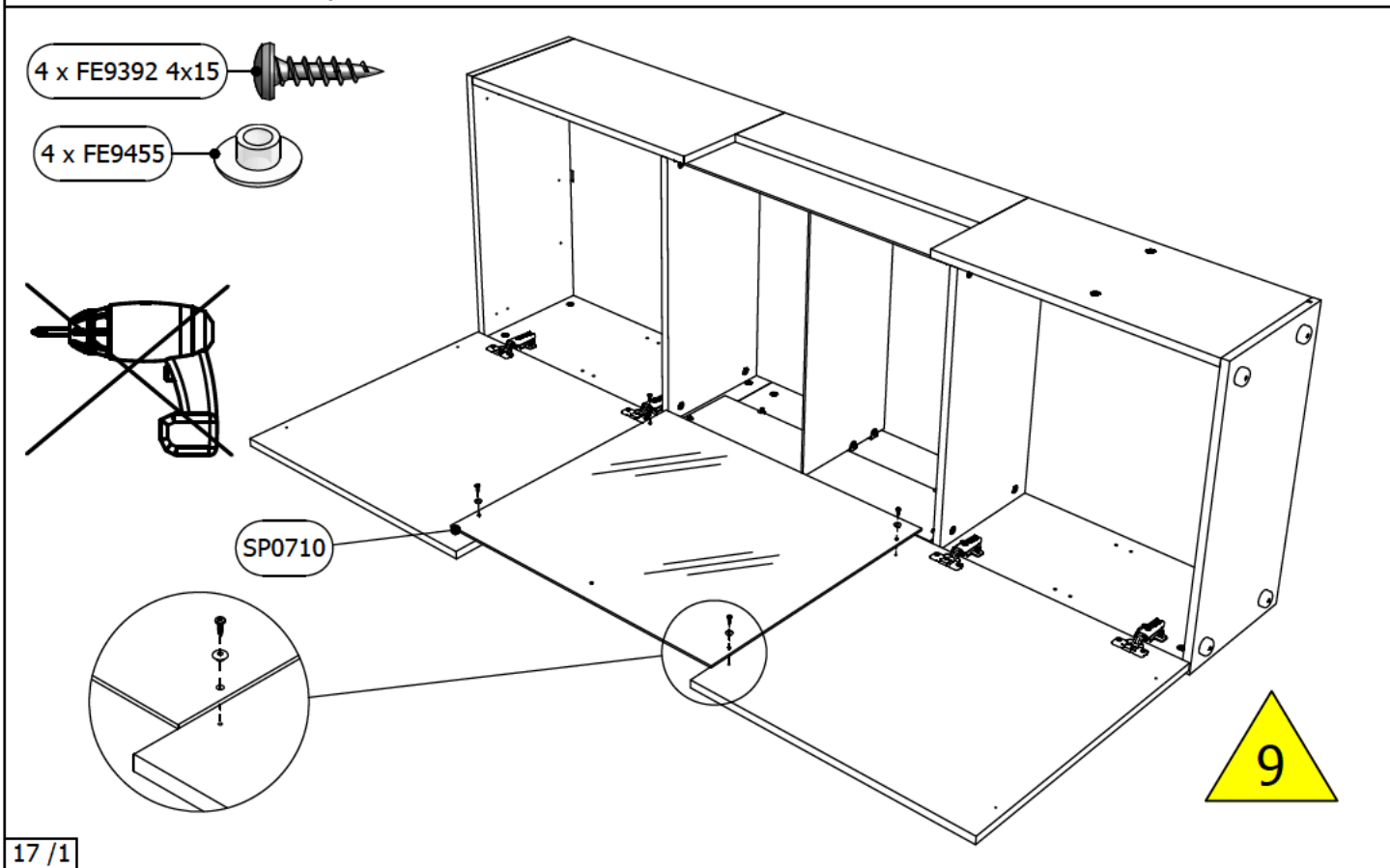
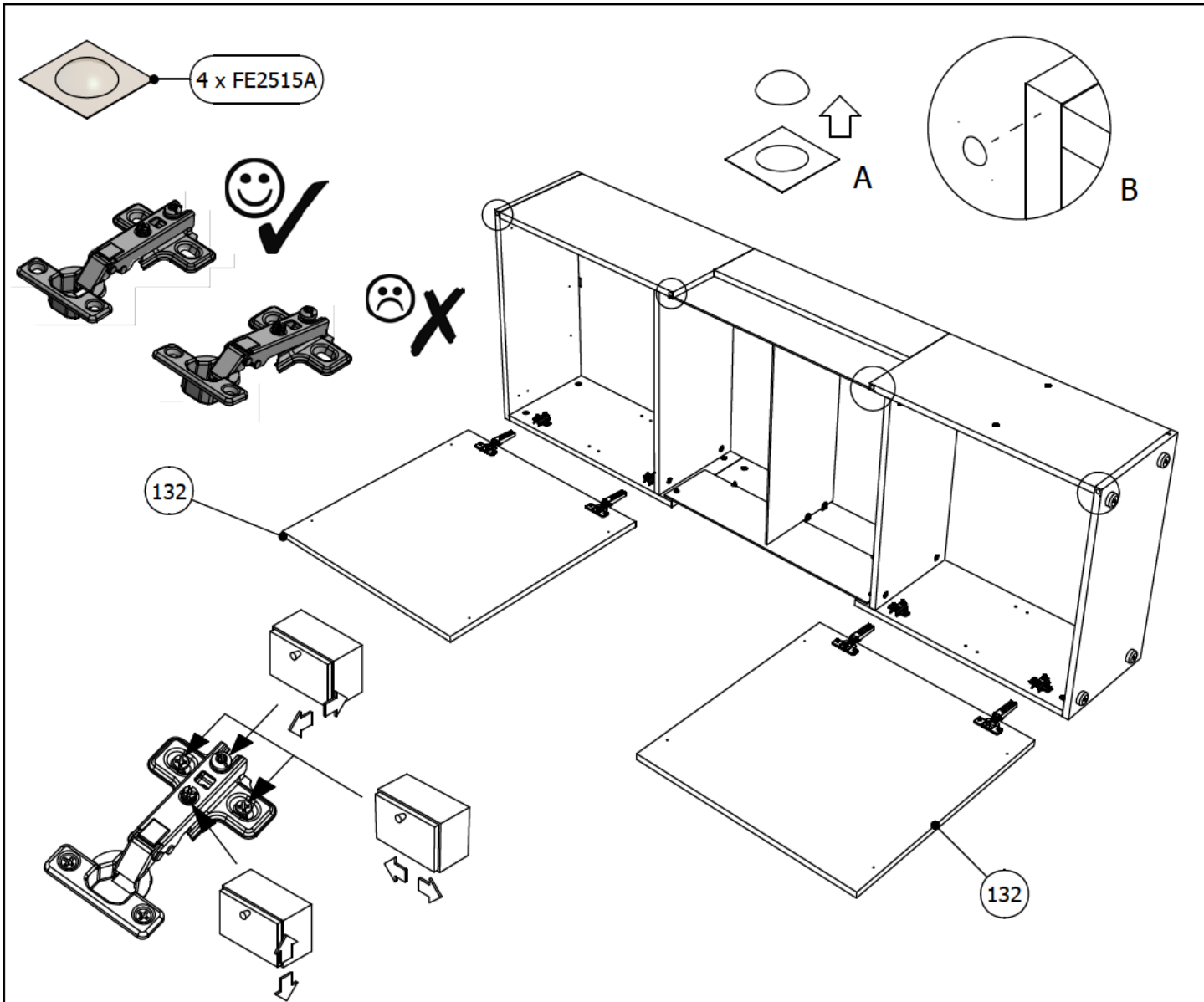

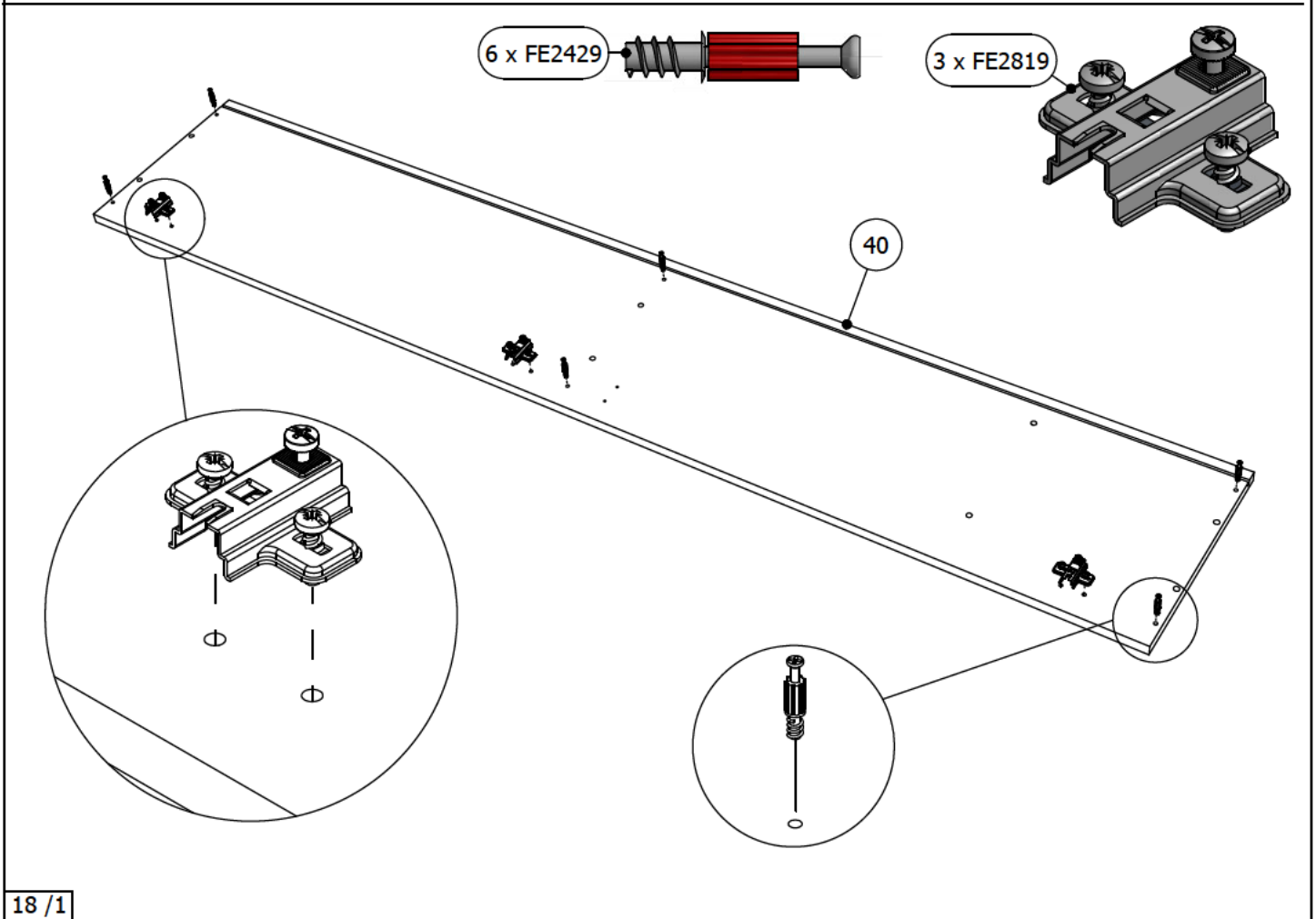
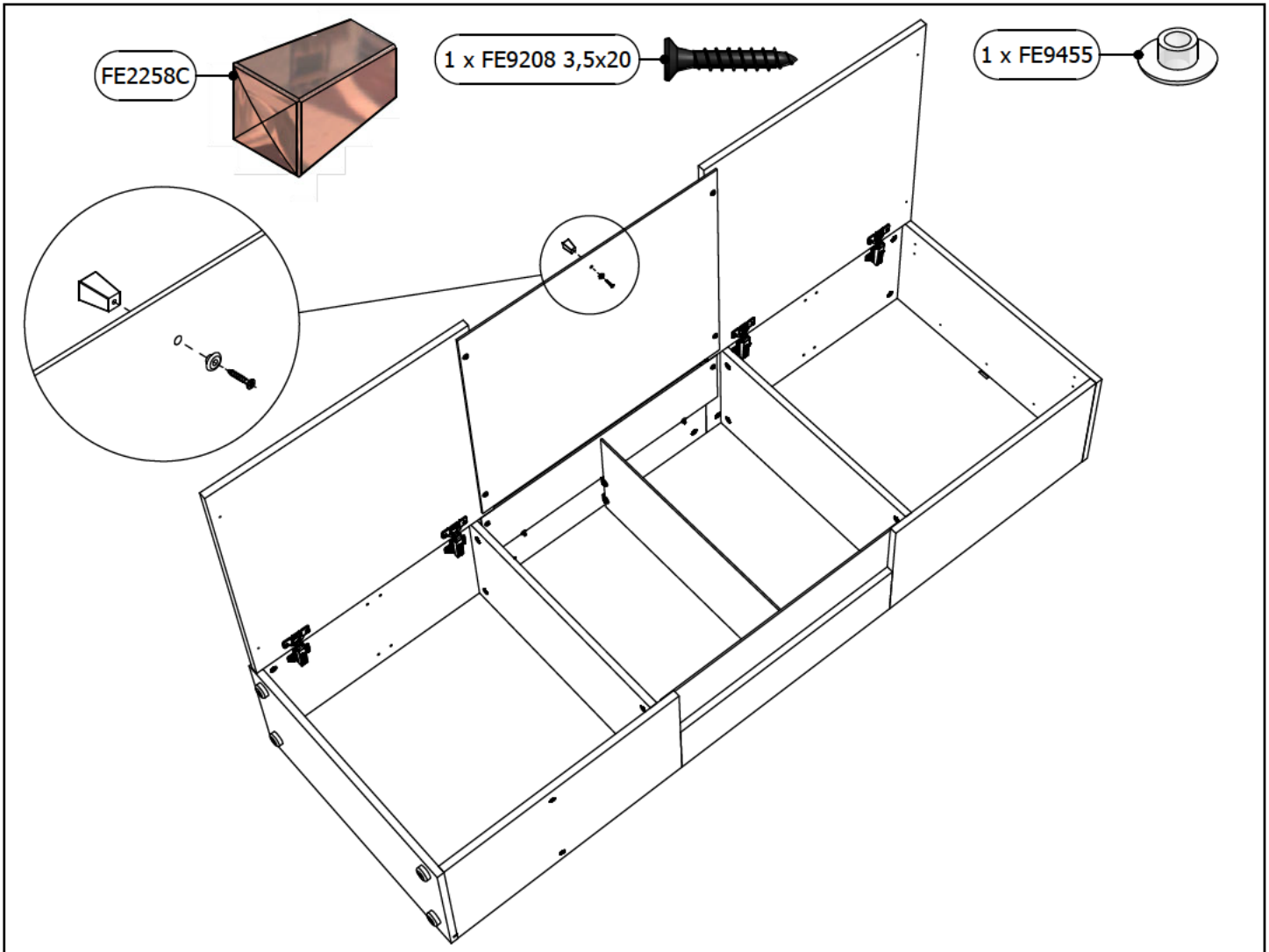

2 x FE2640 K12 - 120N

2 x A



8 x SPL001



6 x D

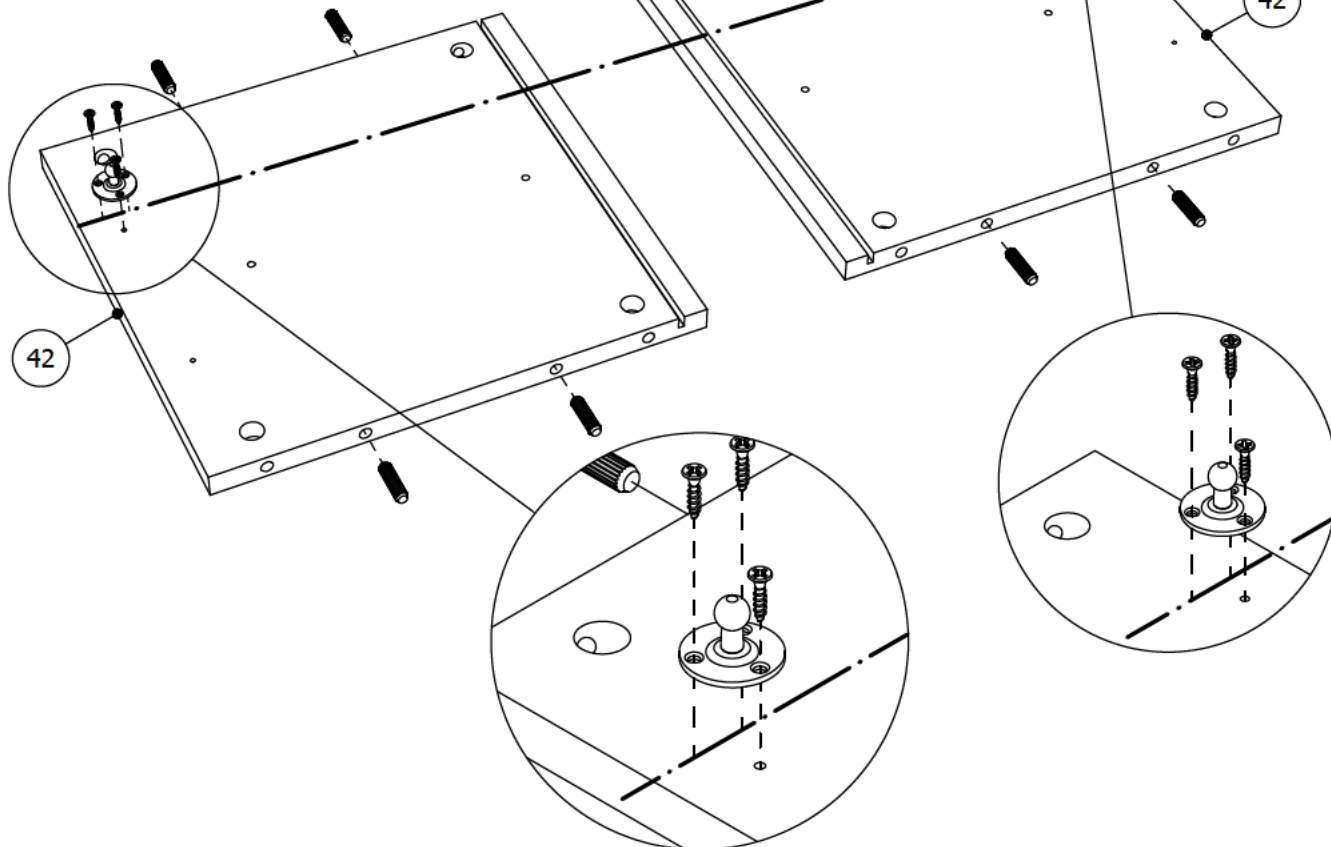

4 x SPL001

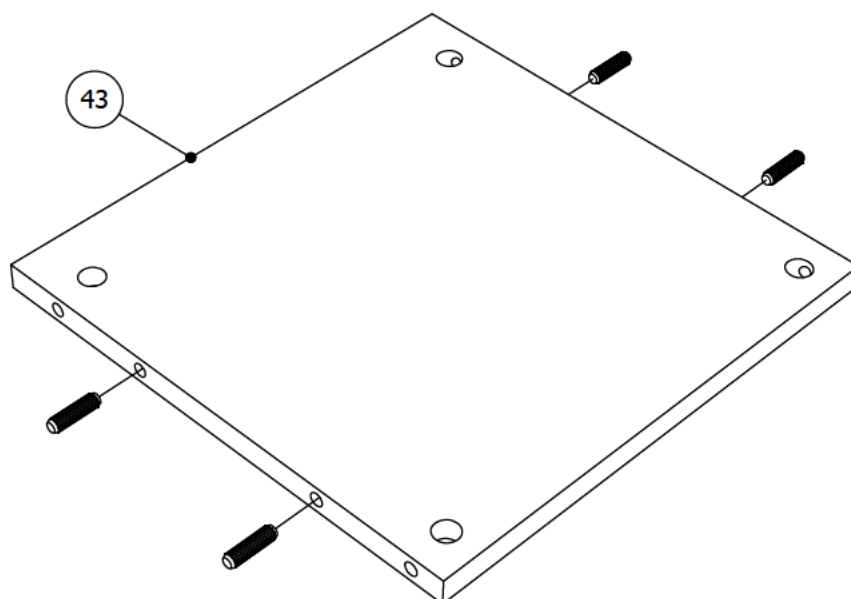

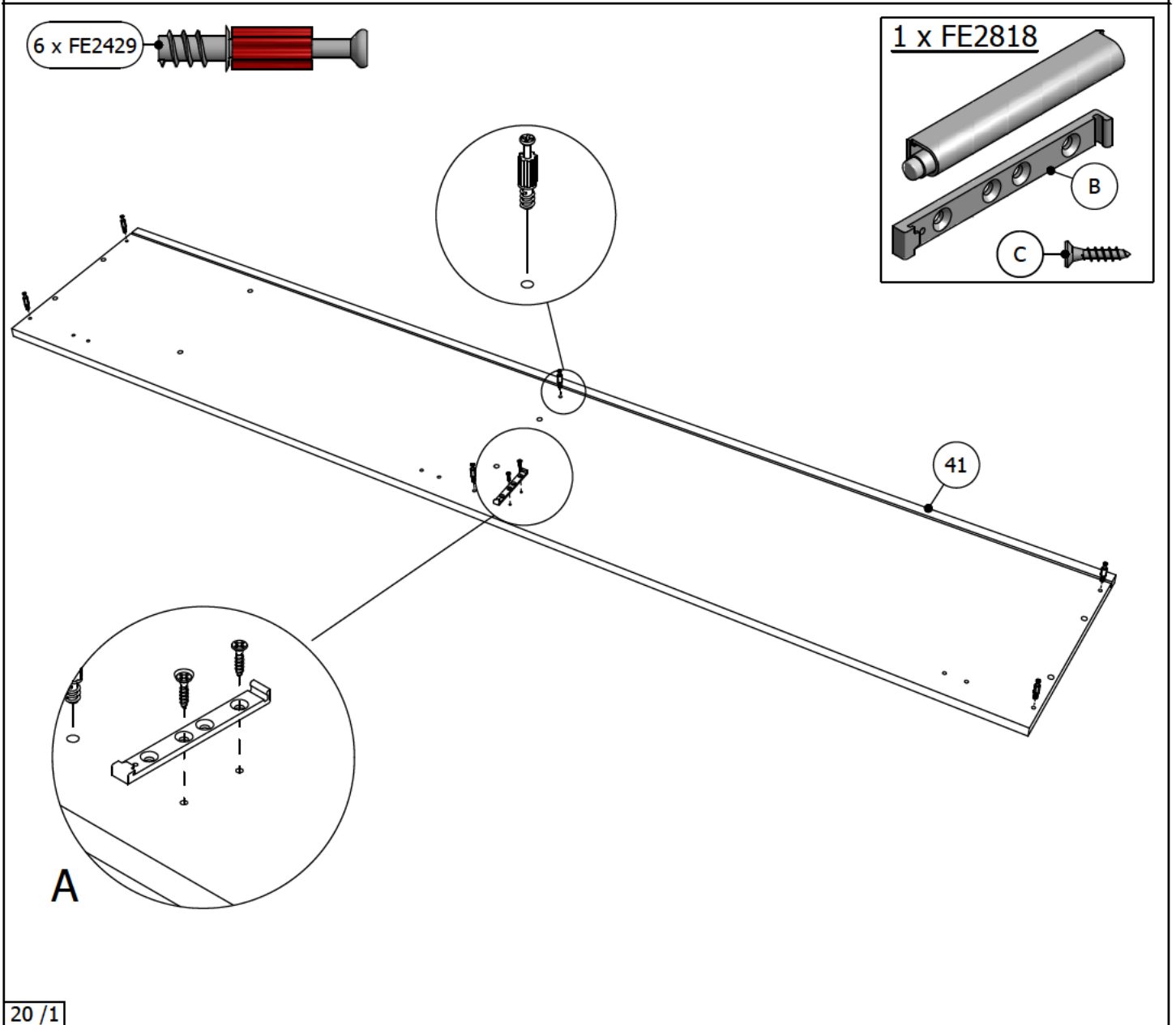
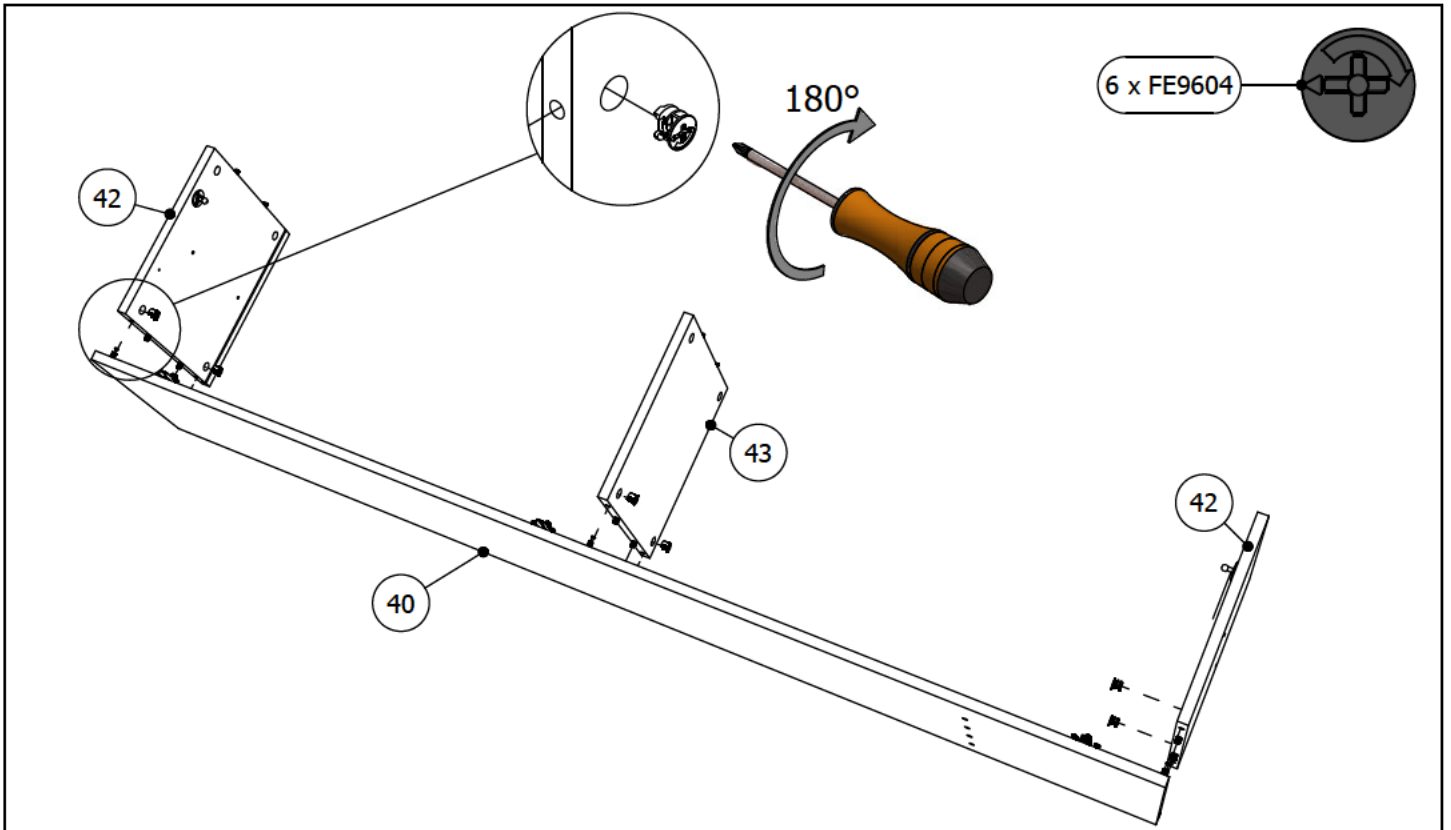

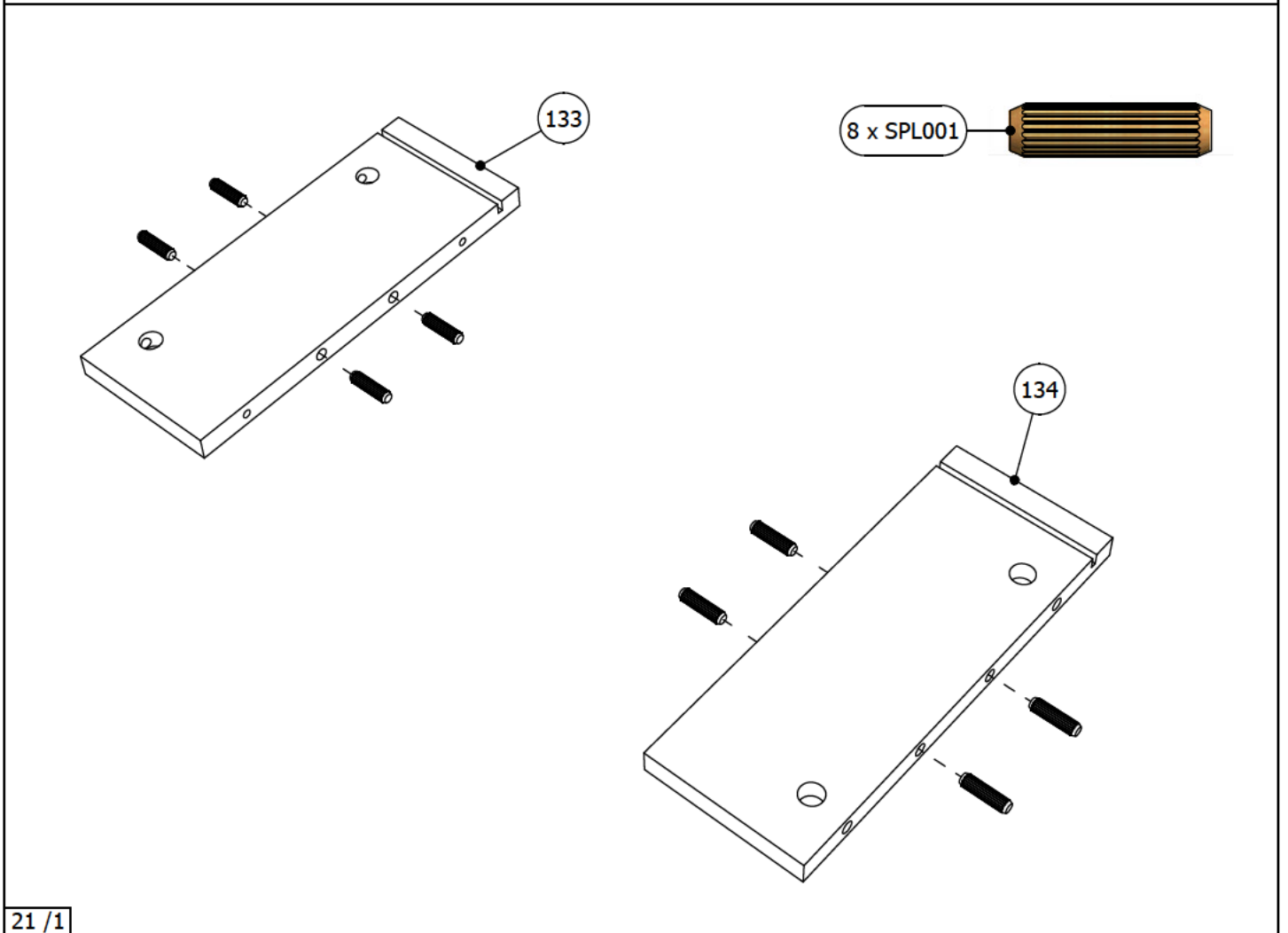
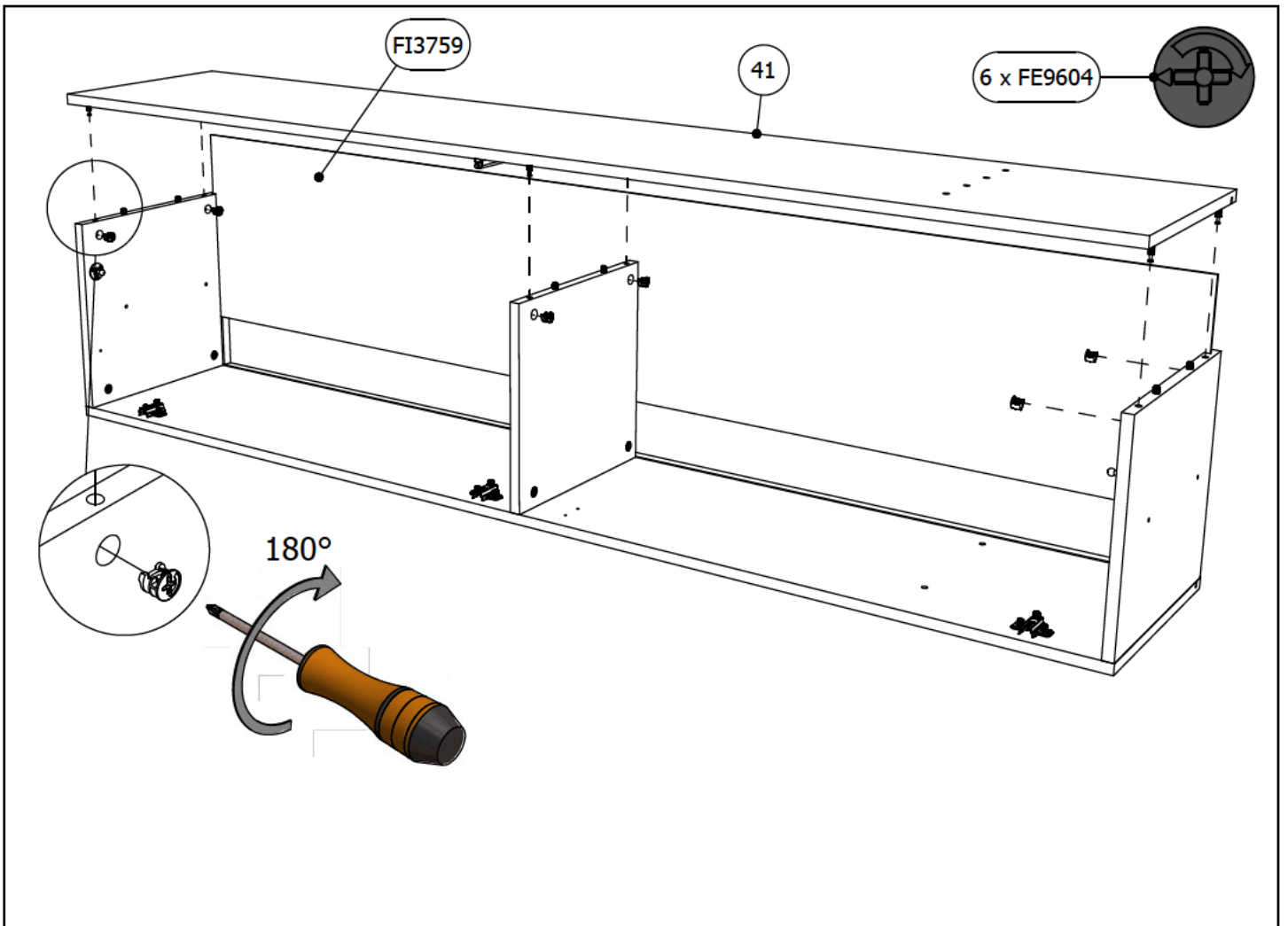

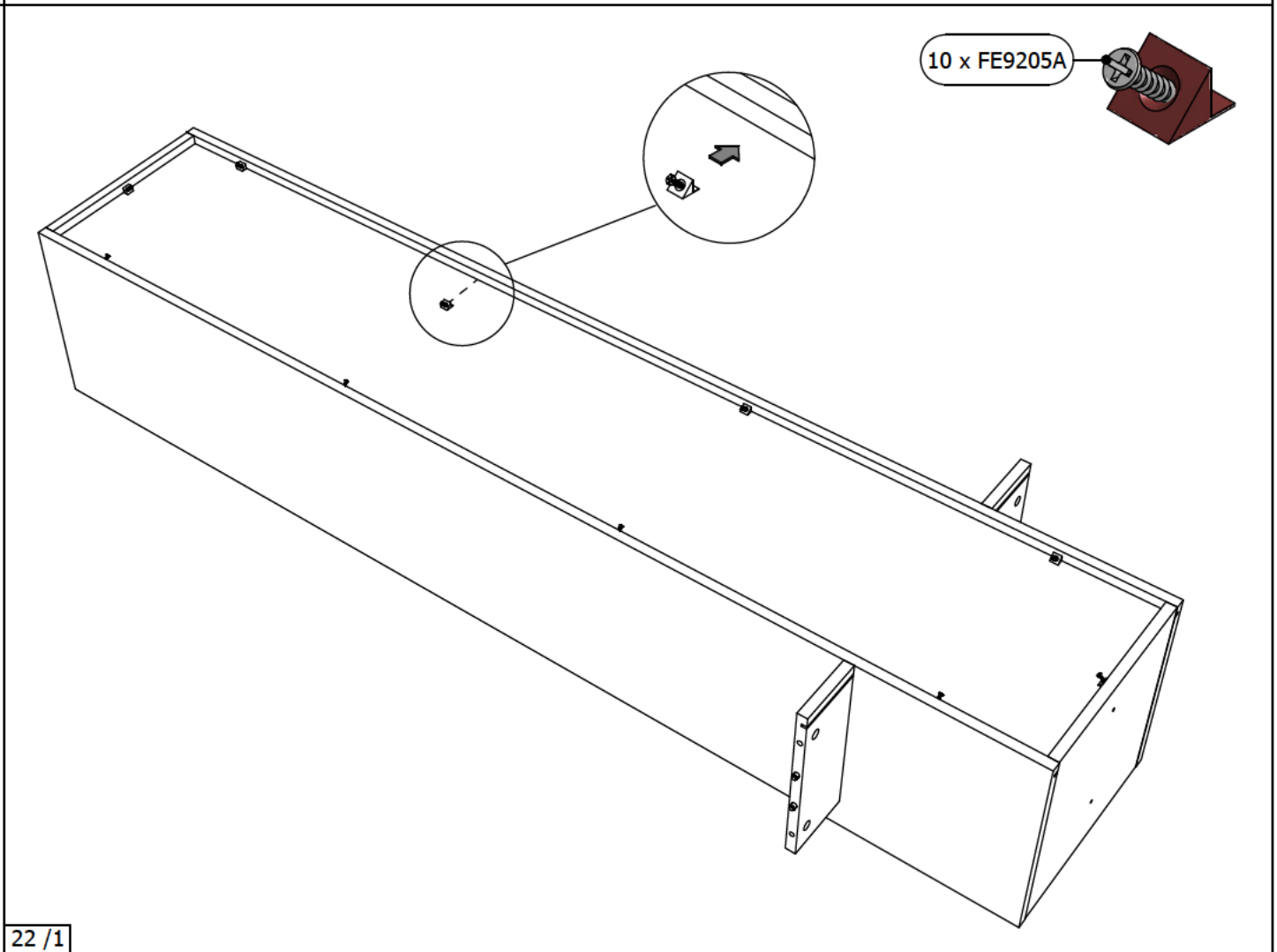
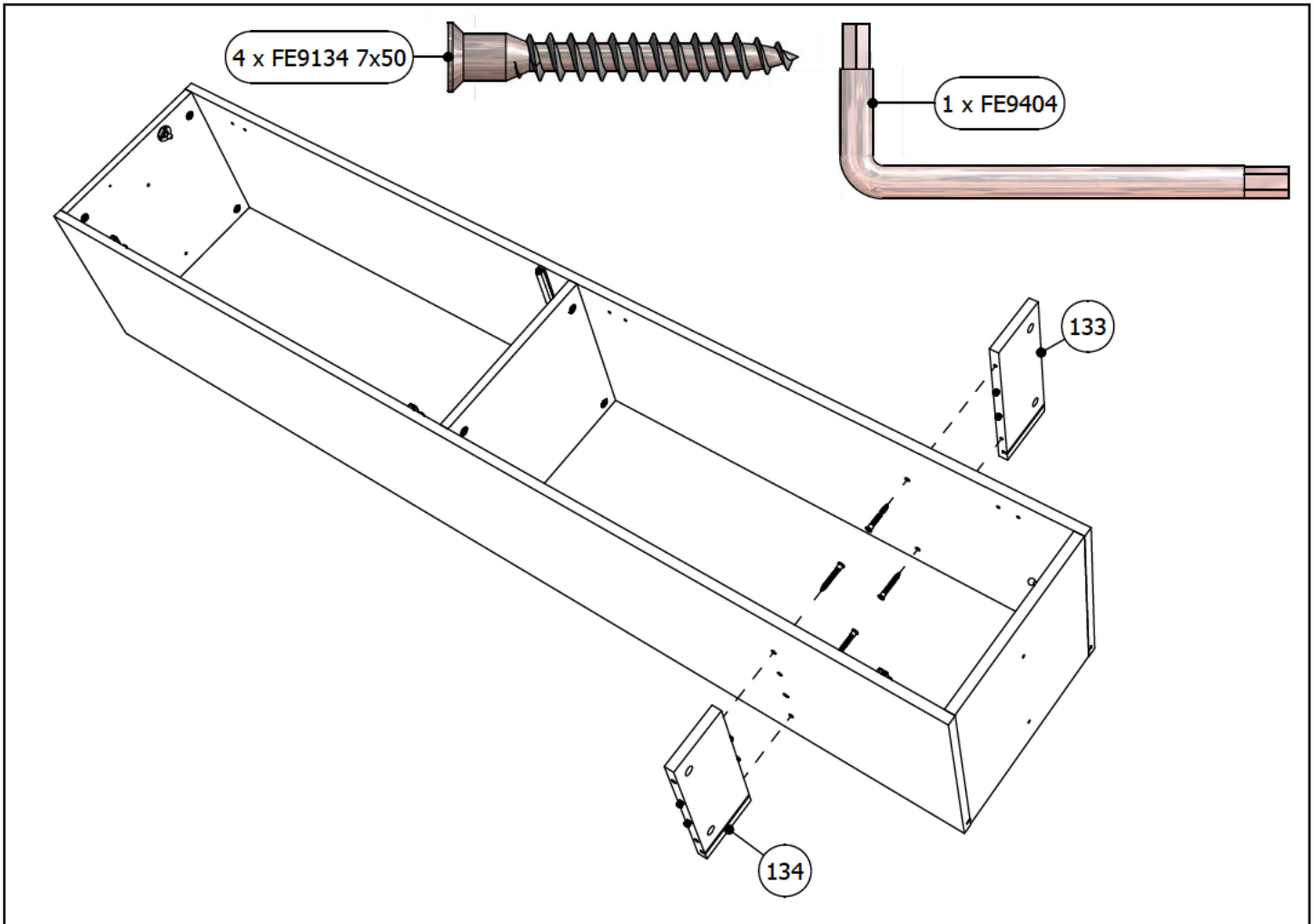

2 x FE9604

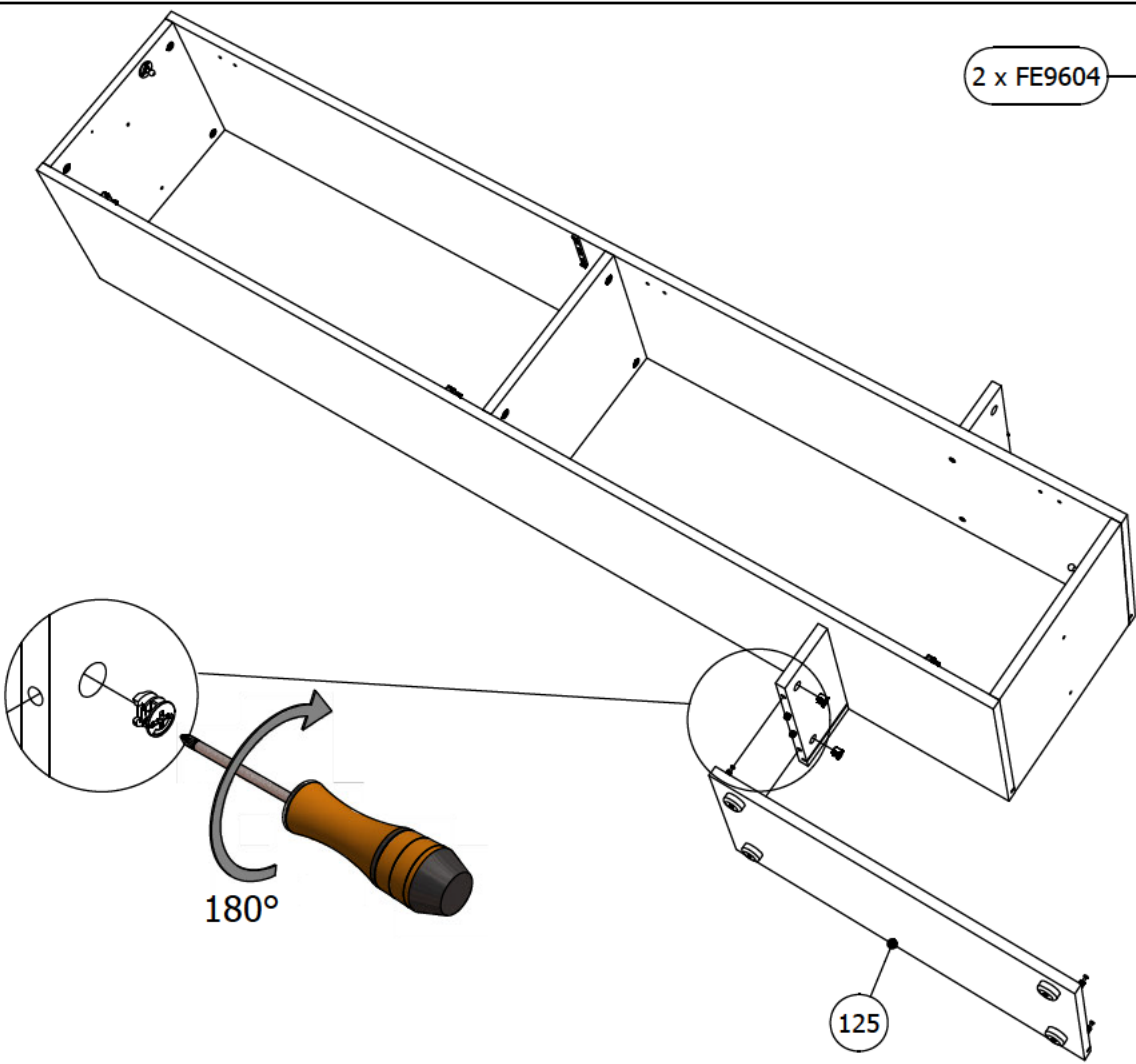

2 x FE9696



2 x FE9302 4MAx22,5

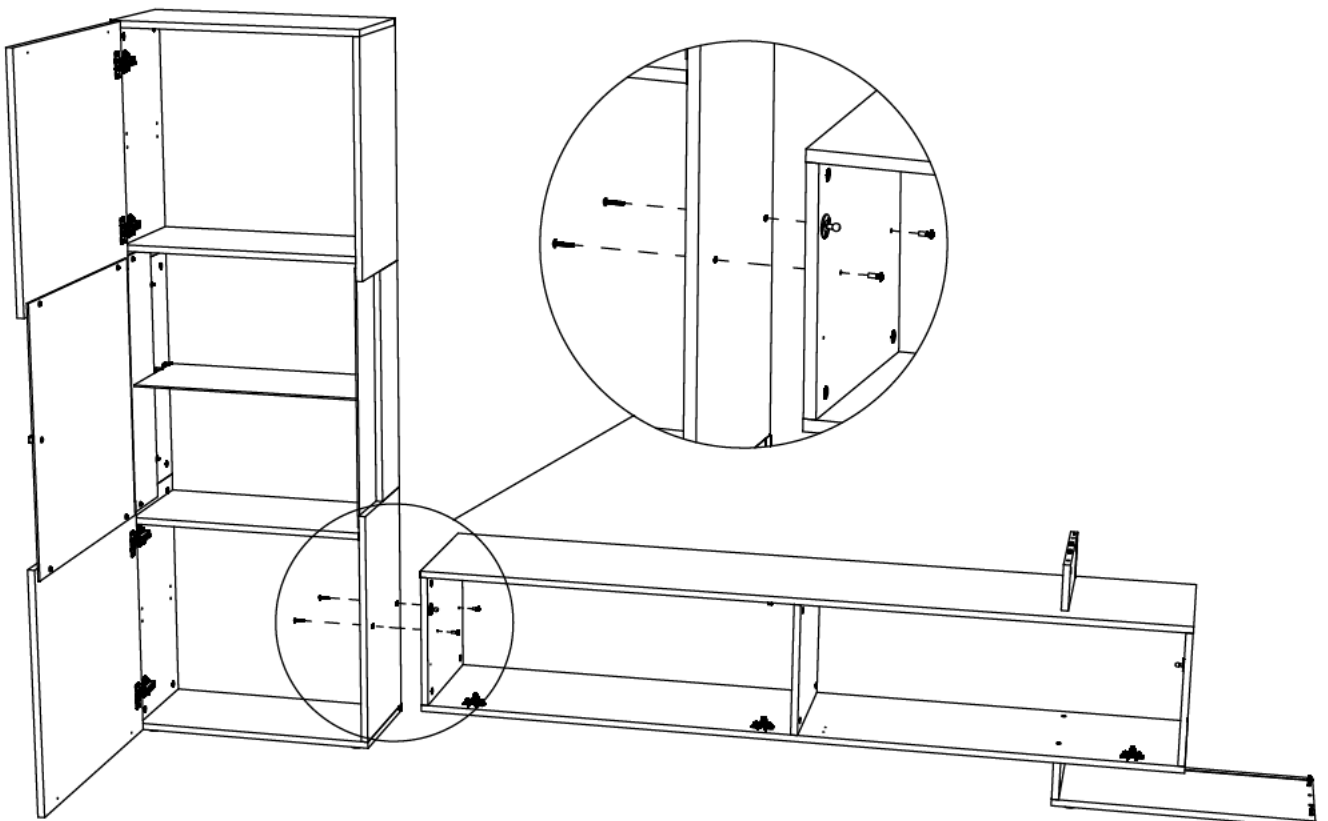

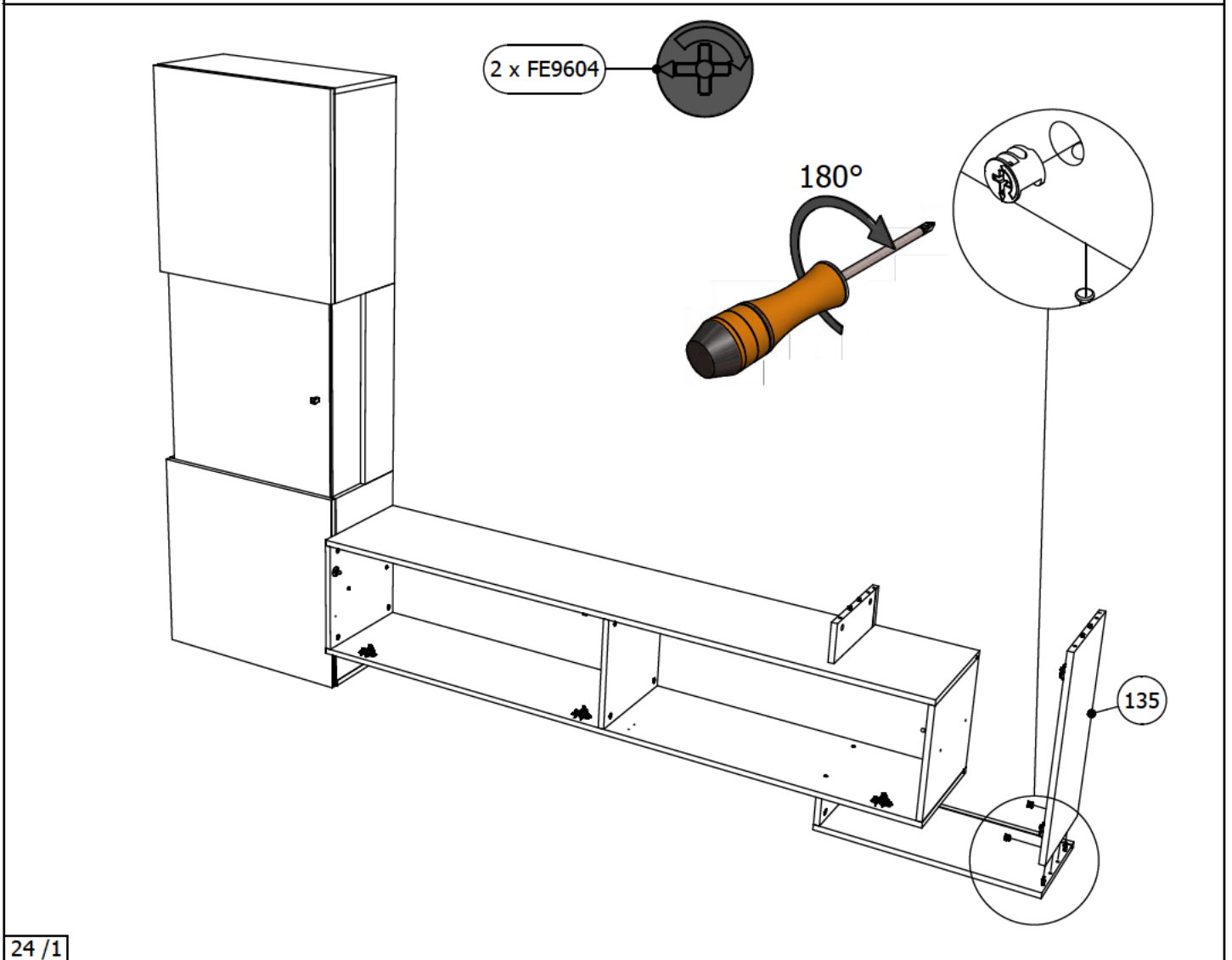
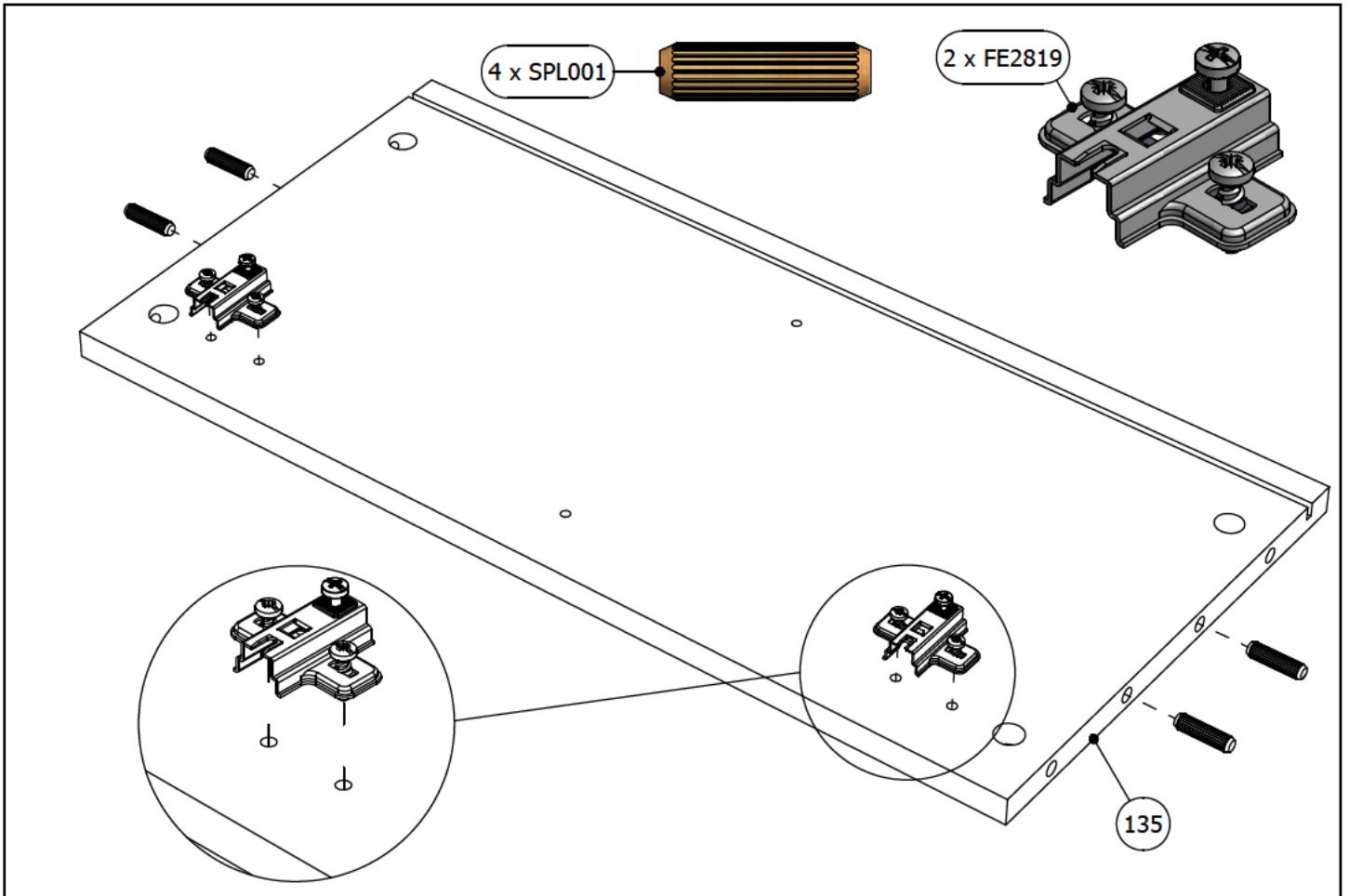

12 x FE2769

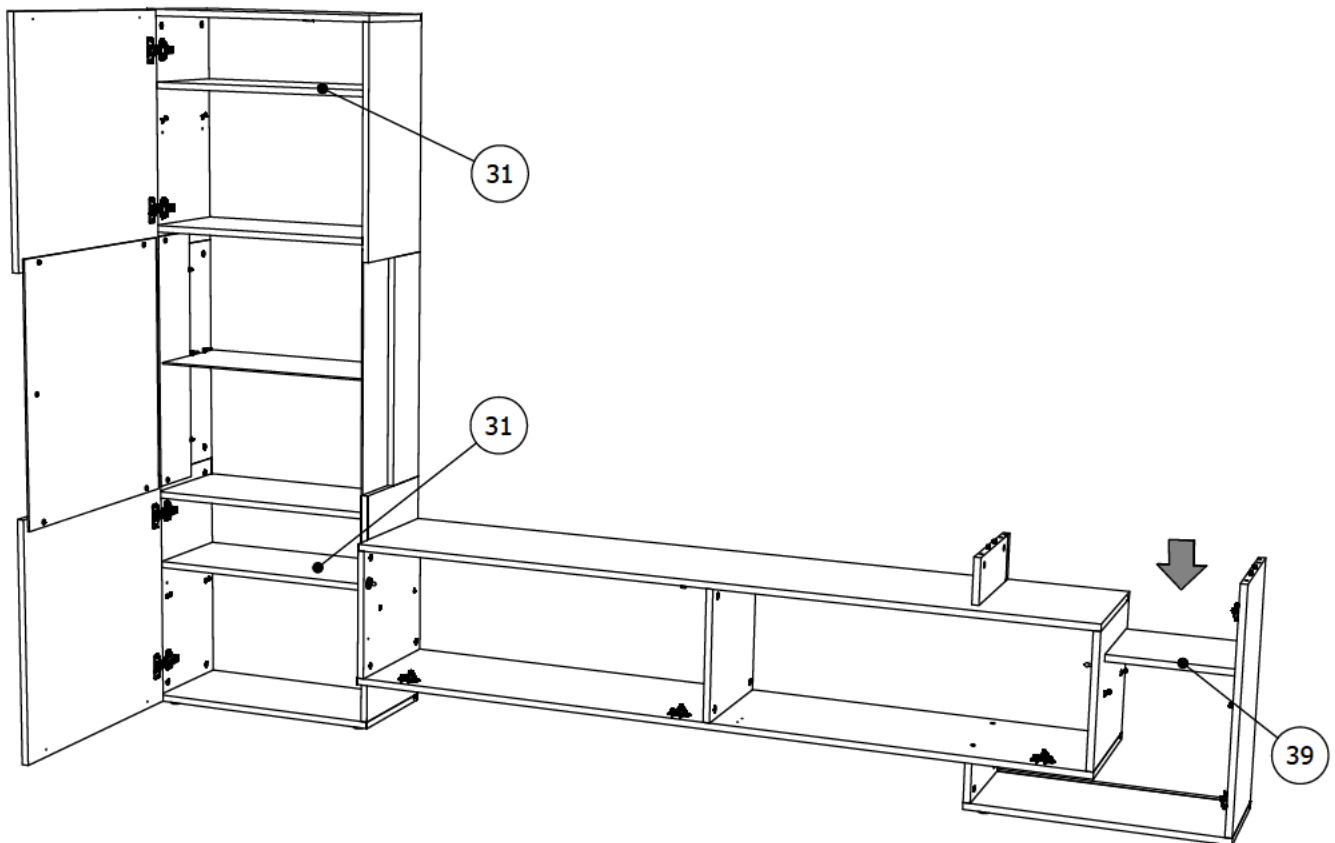
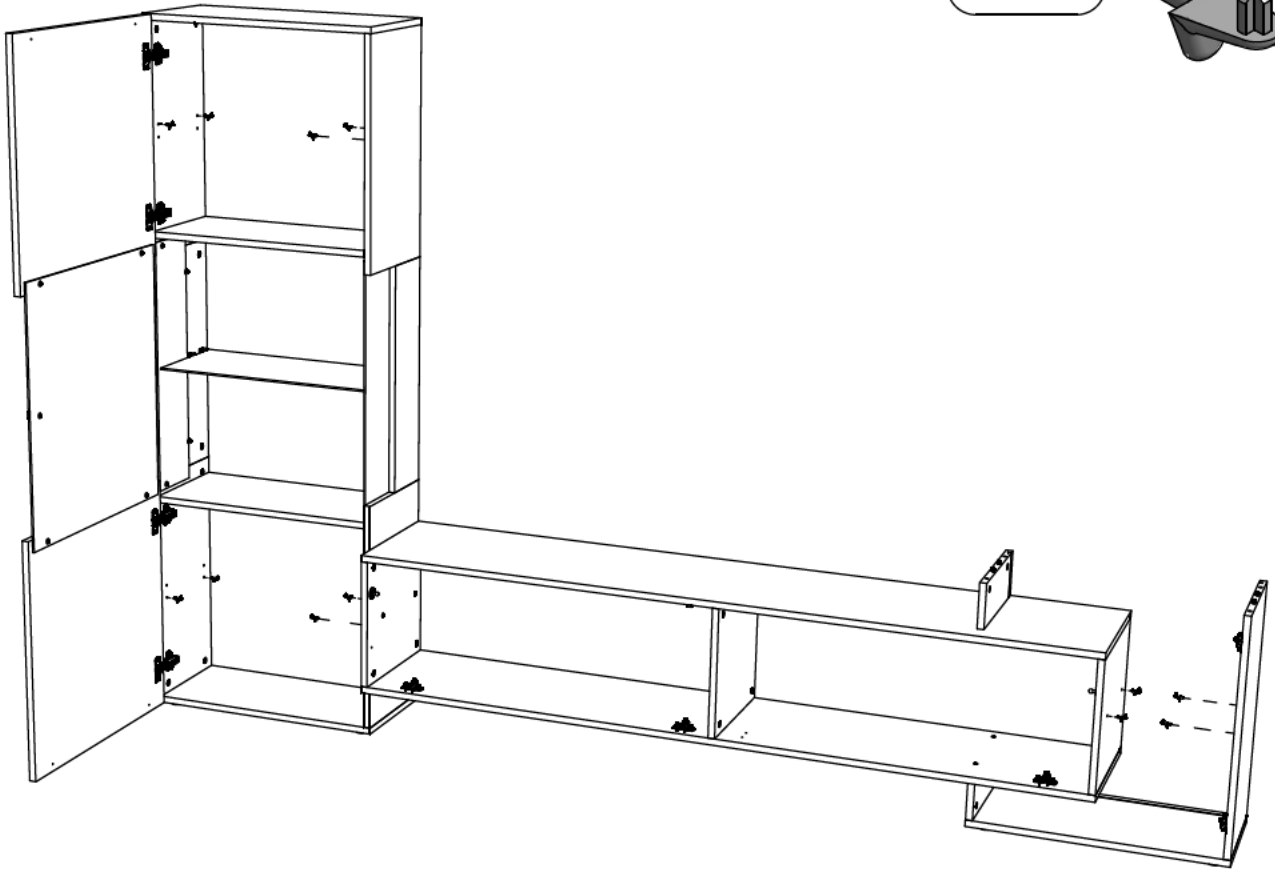

4 x FE2429



1 x FE2818

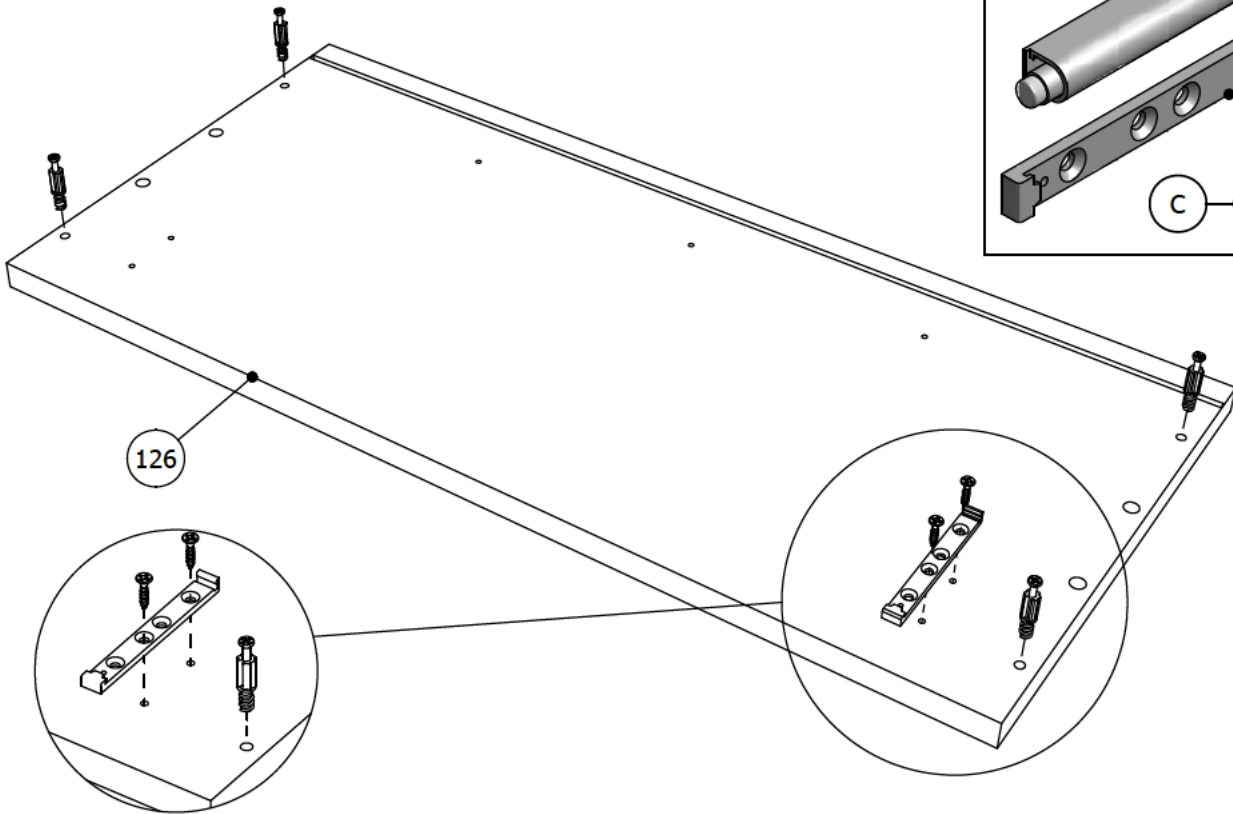
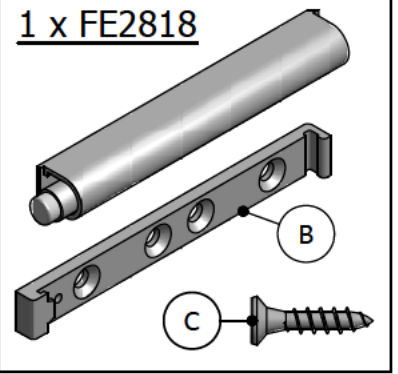

126

B

C

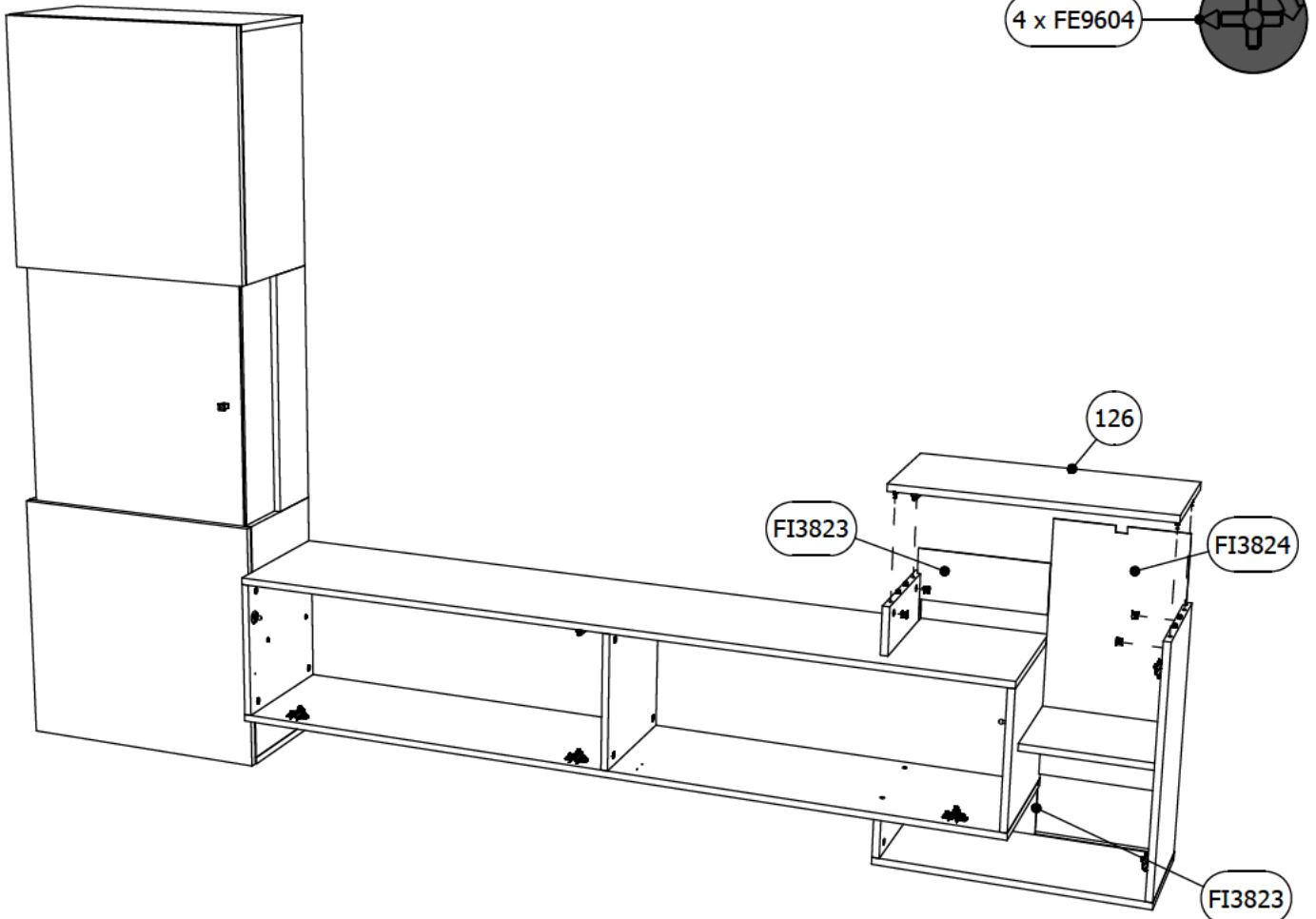

4 x FE9604



126

FI3823

FI3824

FI3823

3 x FE9205A

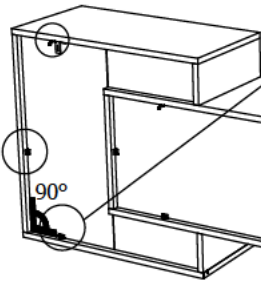
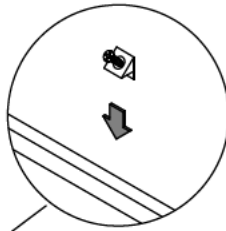

90°

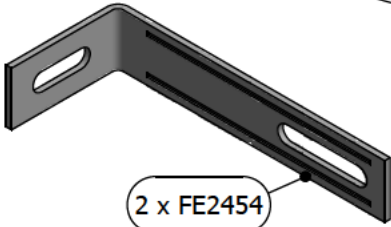
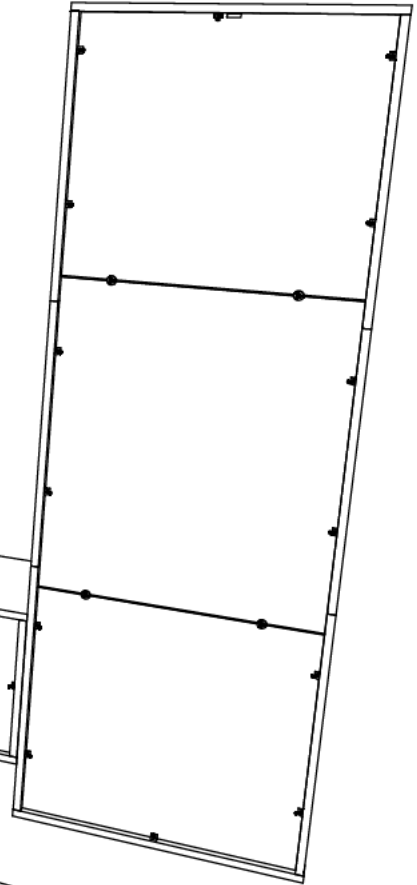

2 x FE2454

270 cm

30 cm

171,5 cm

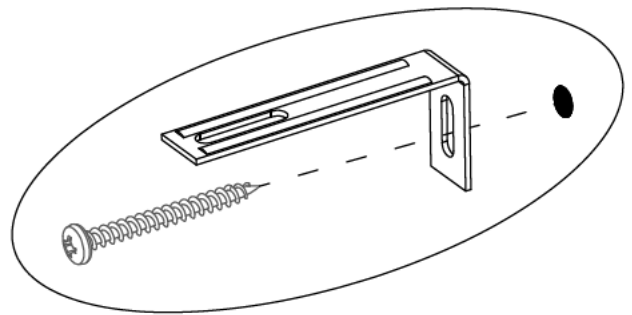

19

15,5 cm

57,8 cm

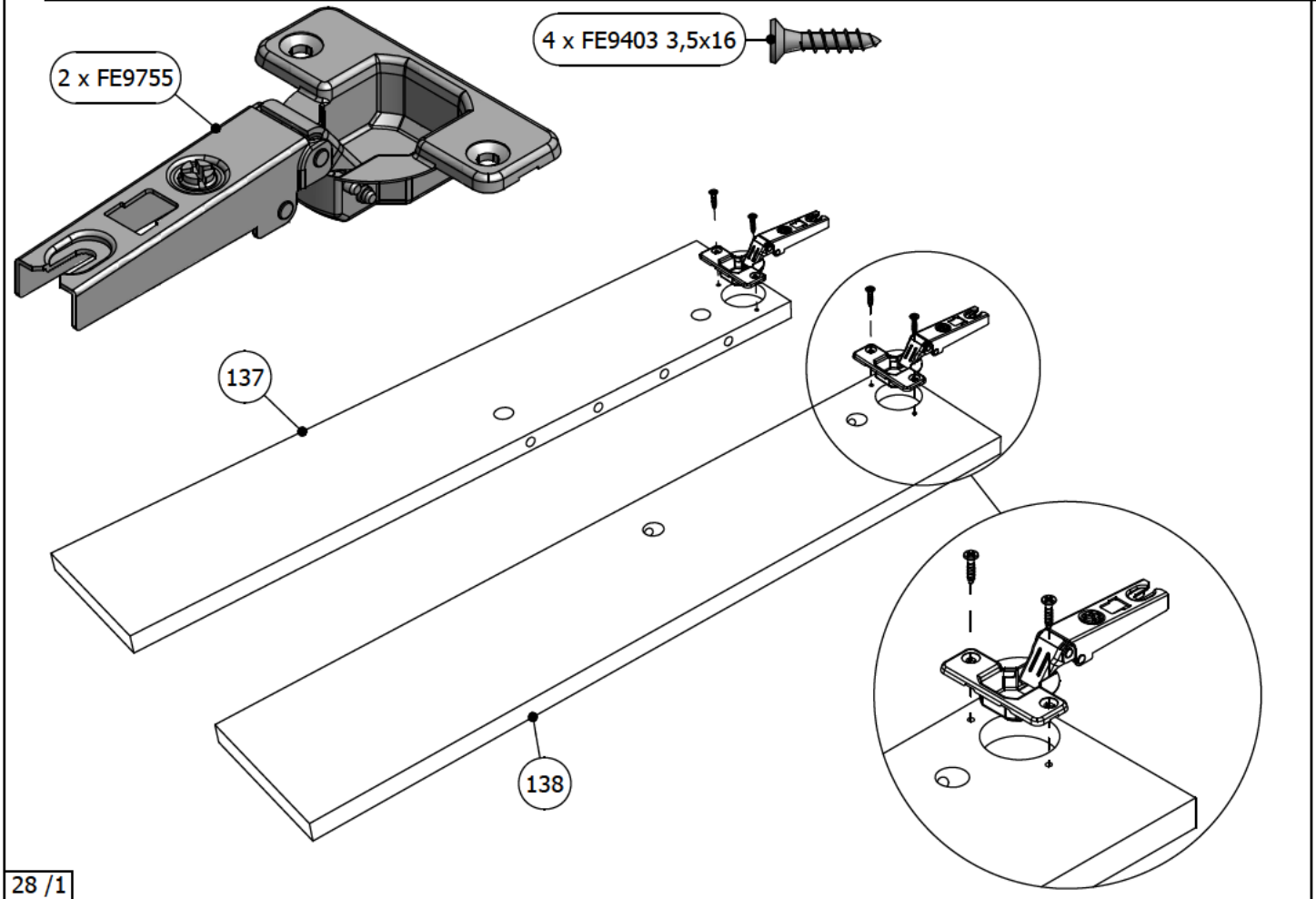
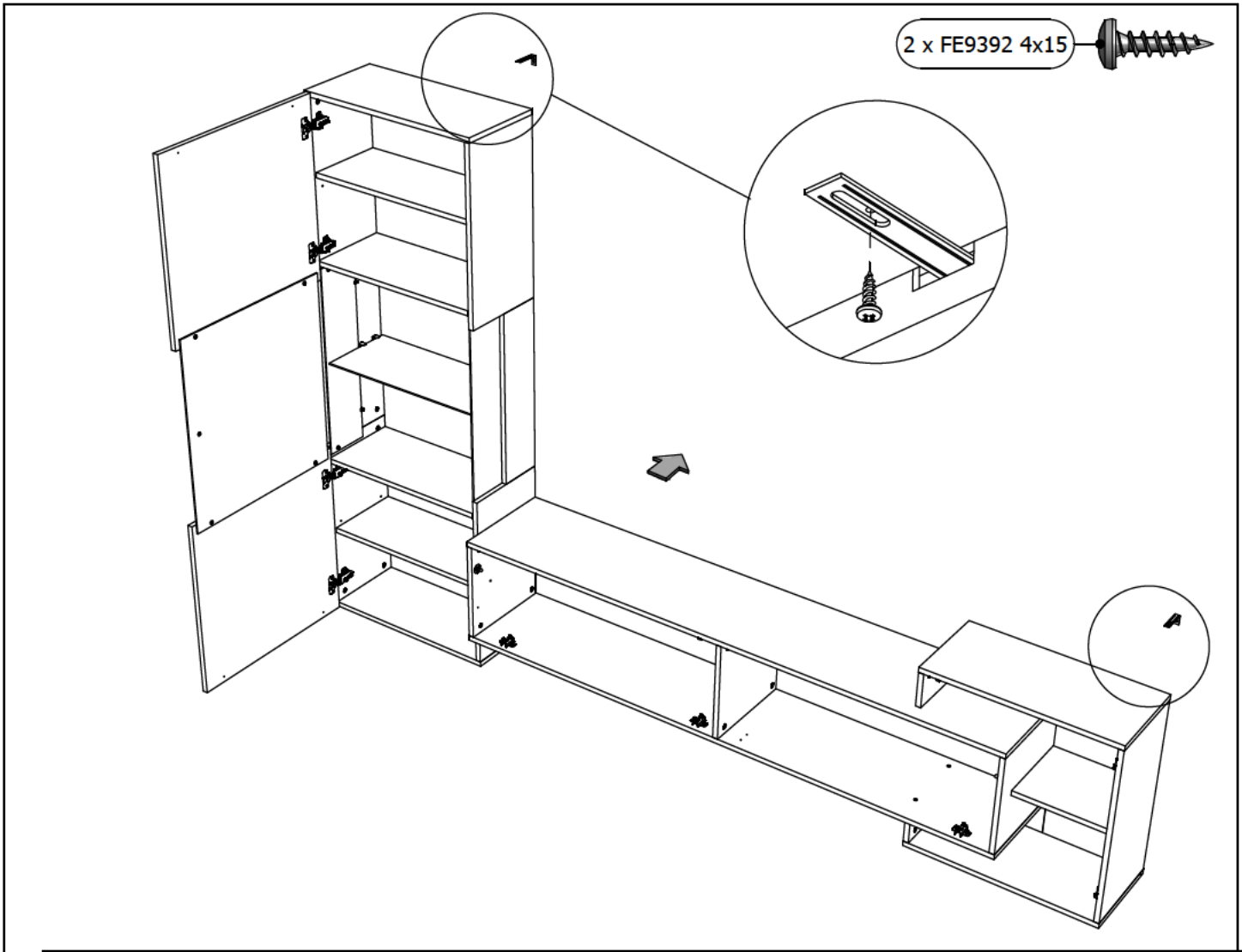

4 x FE2279



4 x SPL001



4 x FE9604

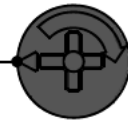

36

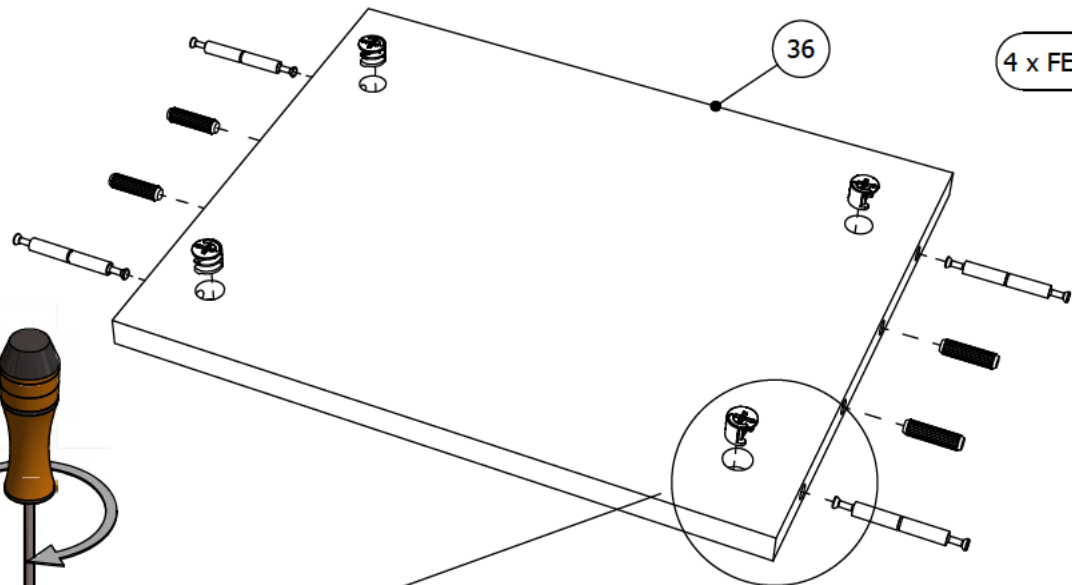

180°

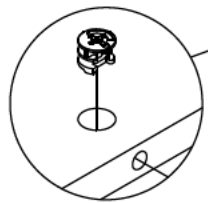

4 x FE9604

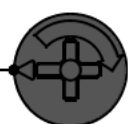

8 x FE2457



137

36

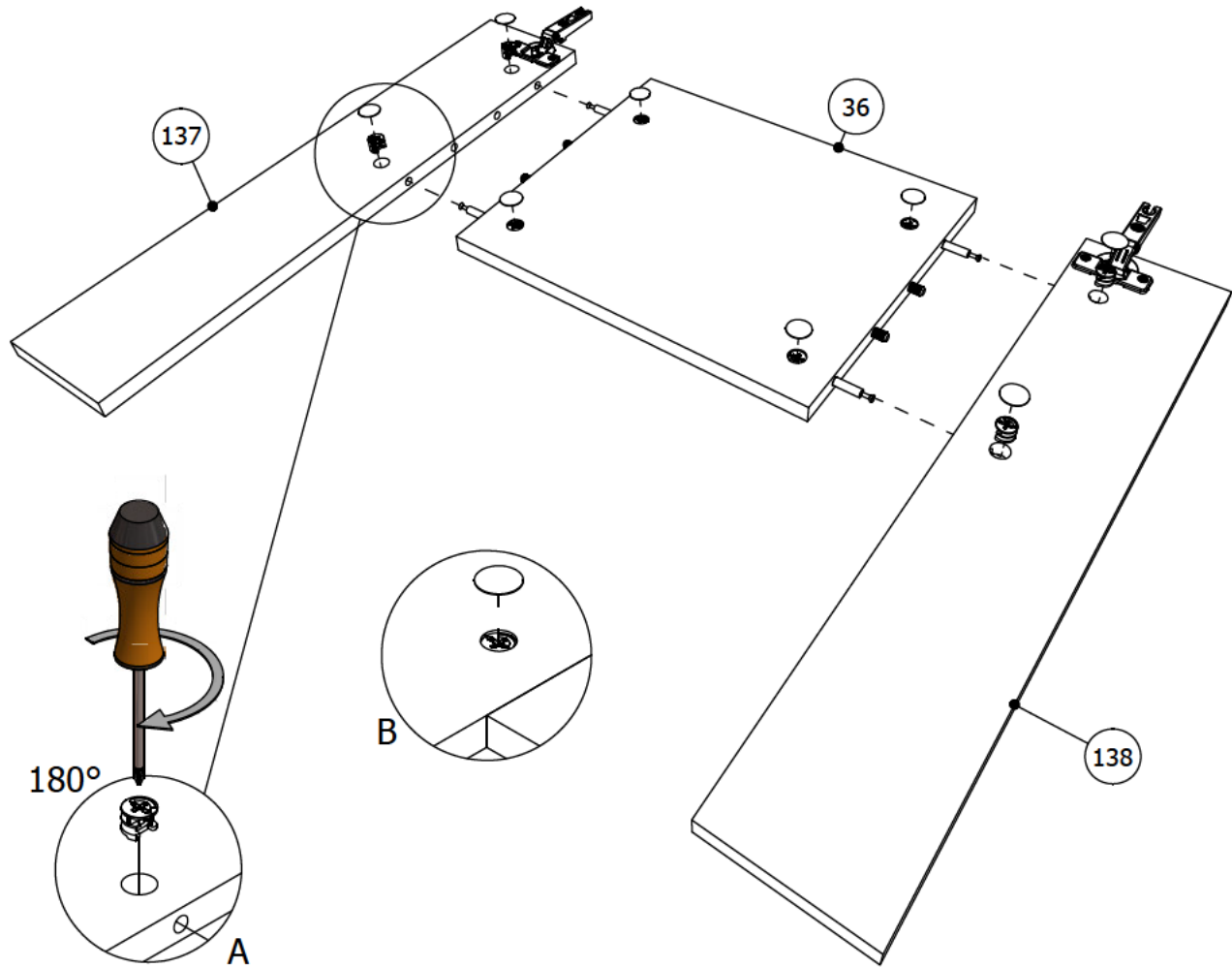

180°



B

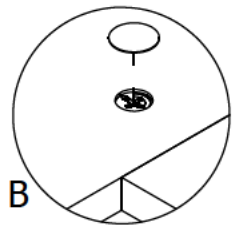

138

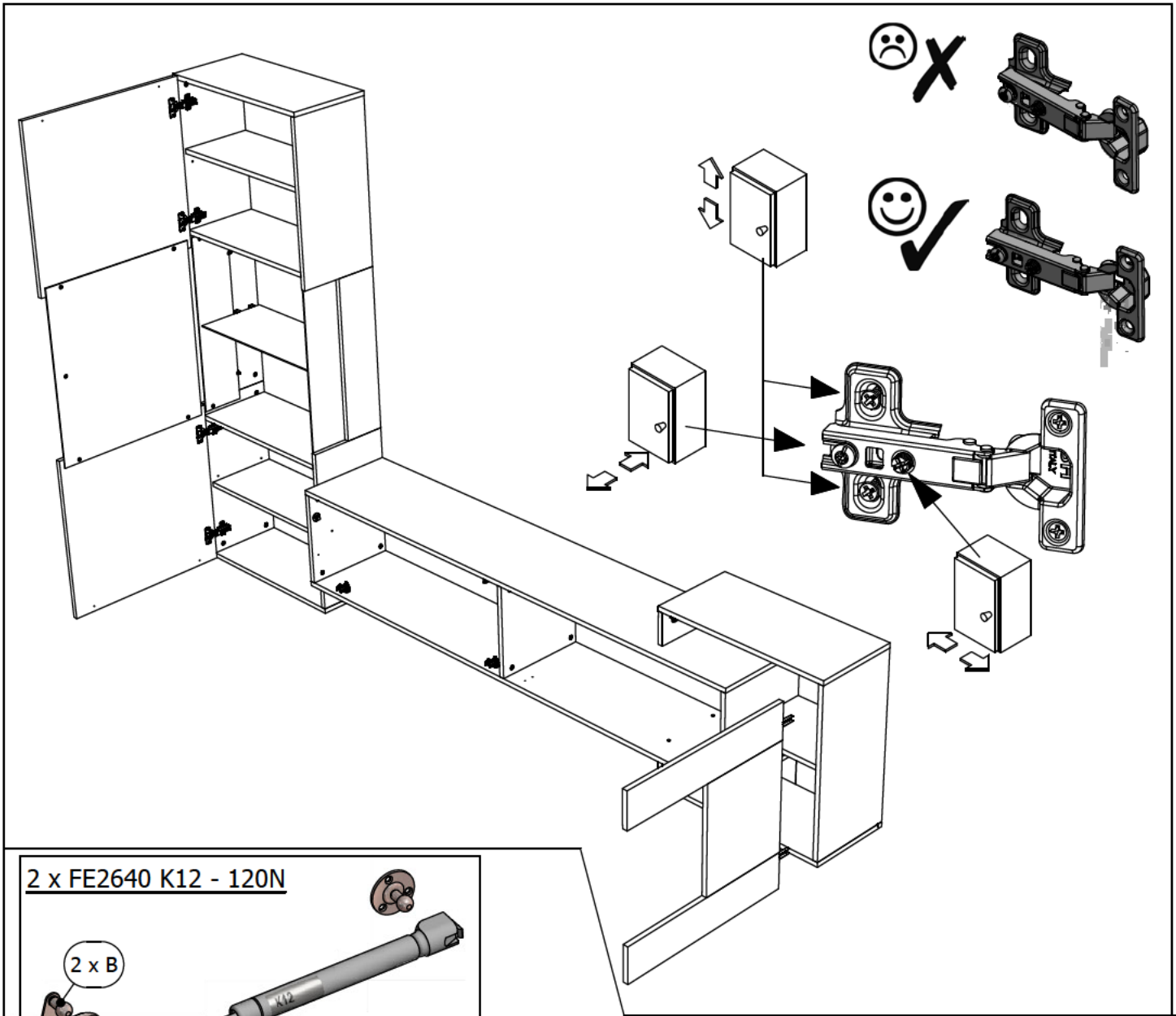

2 x FE2640 K12 - 120N

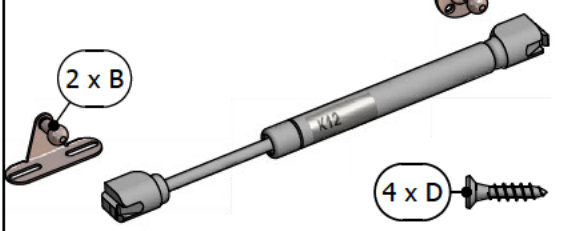

6 x FE9403 3,5x16

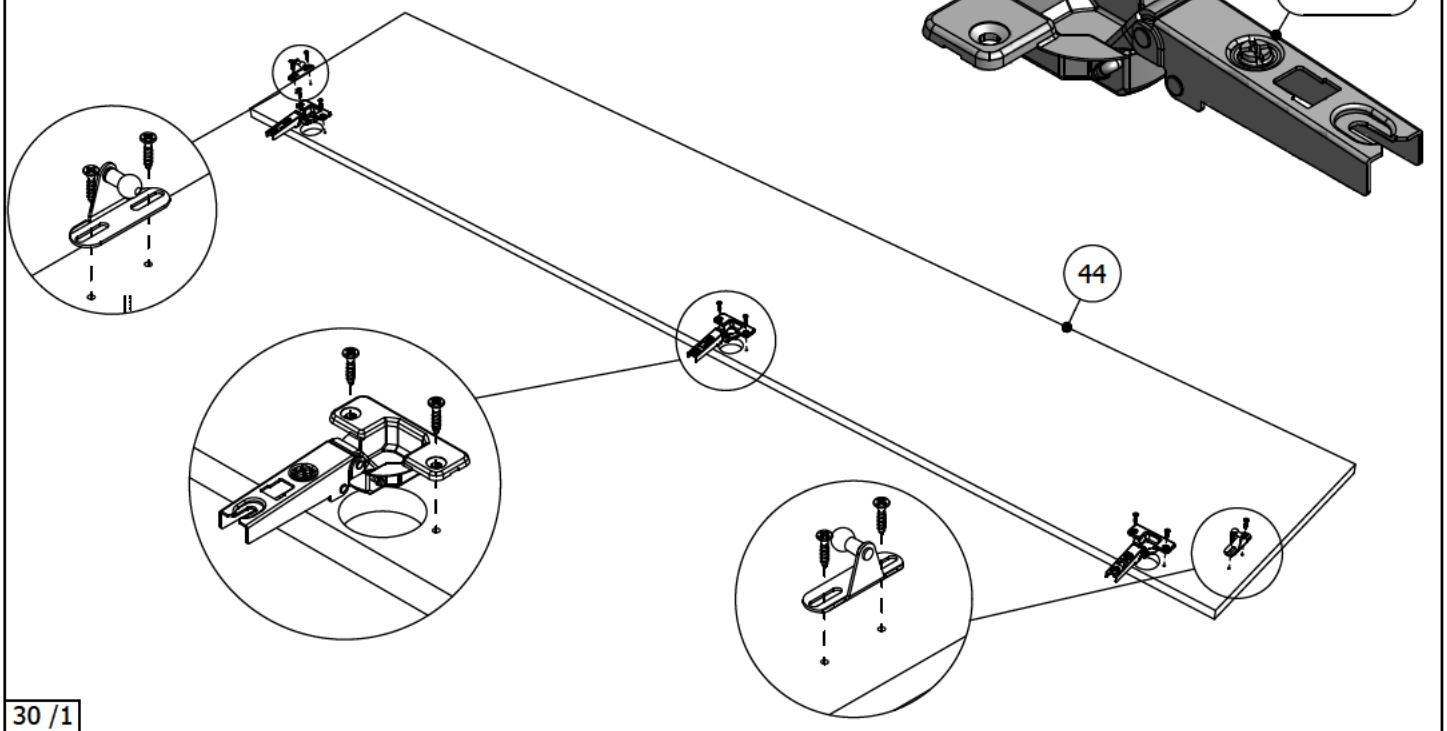
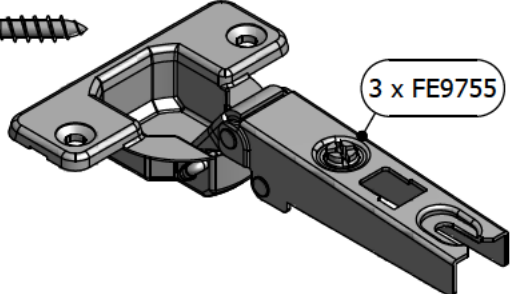

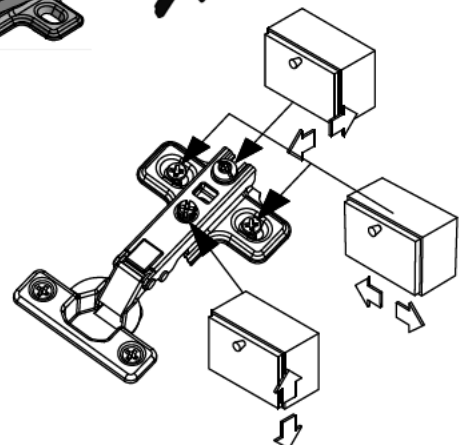
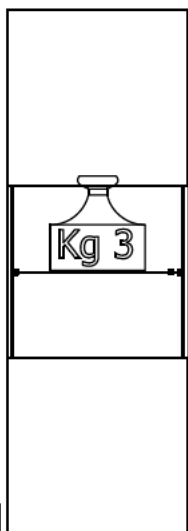
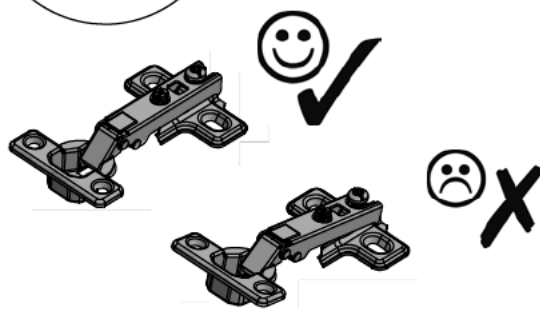
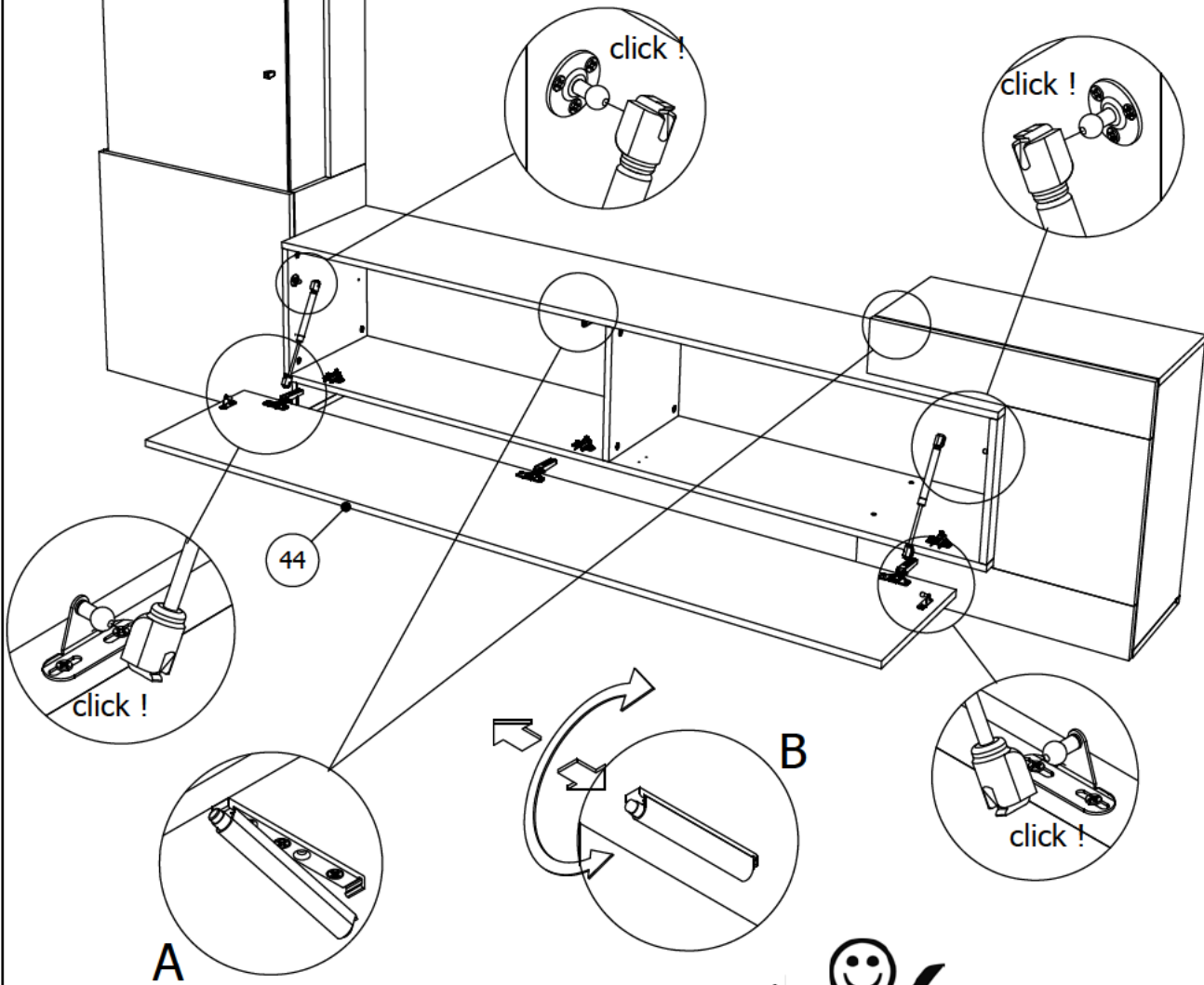
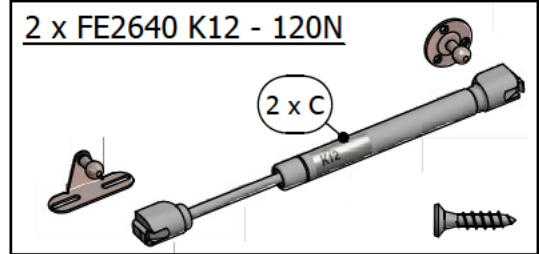
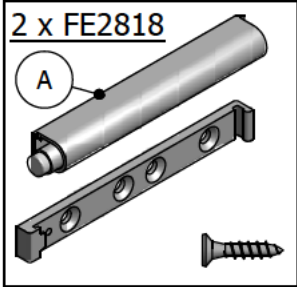

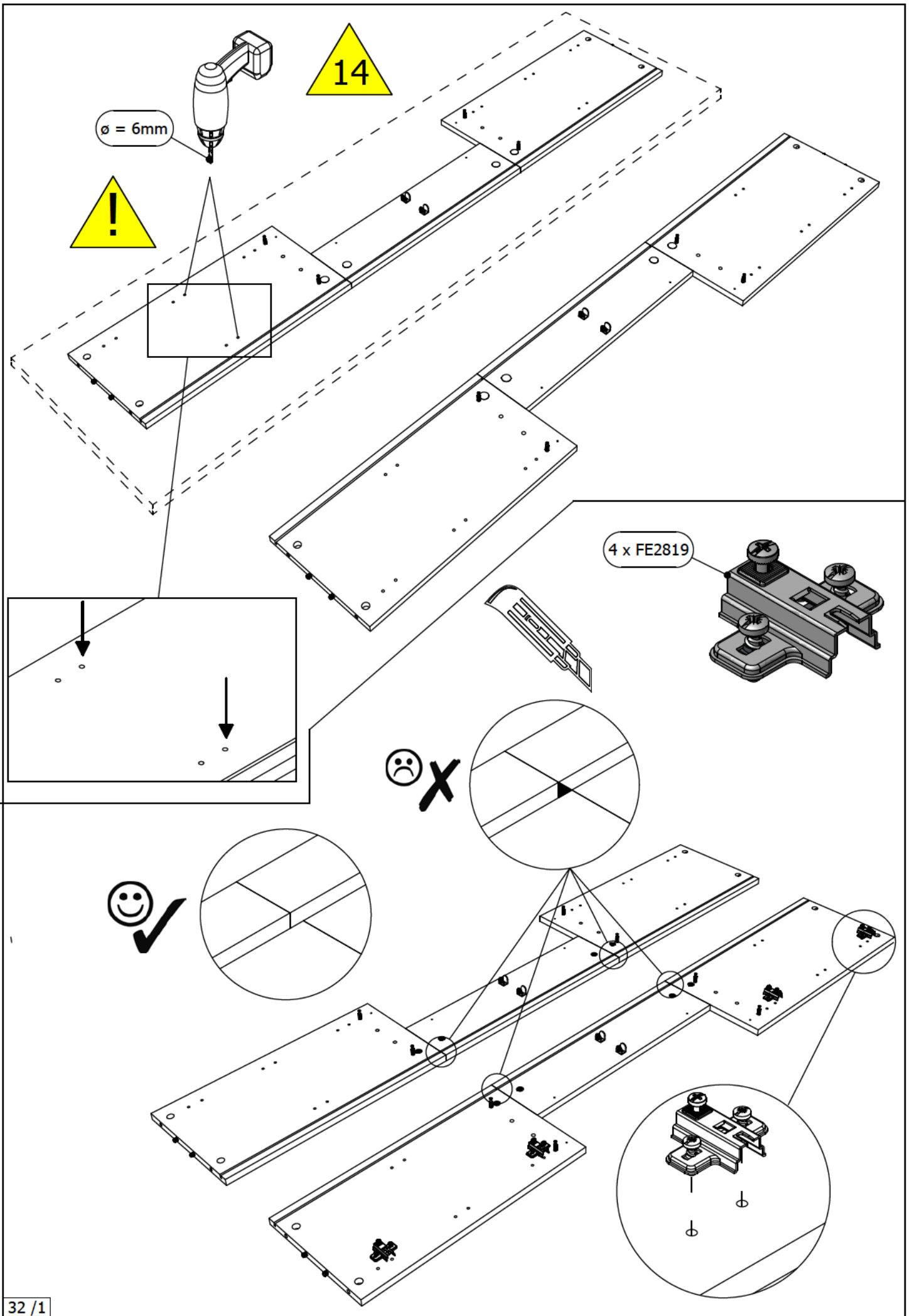

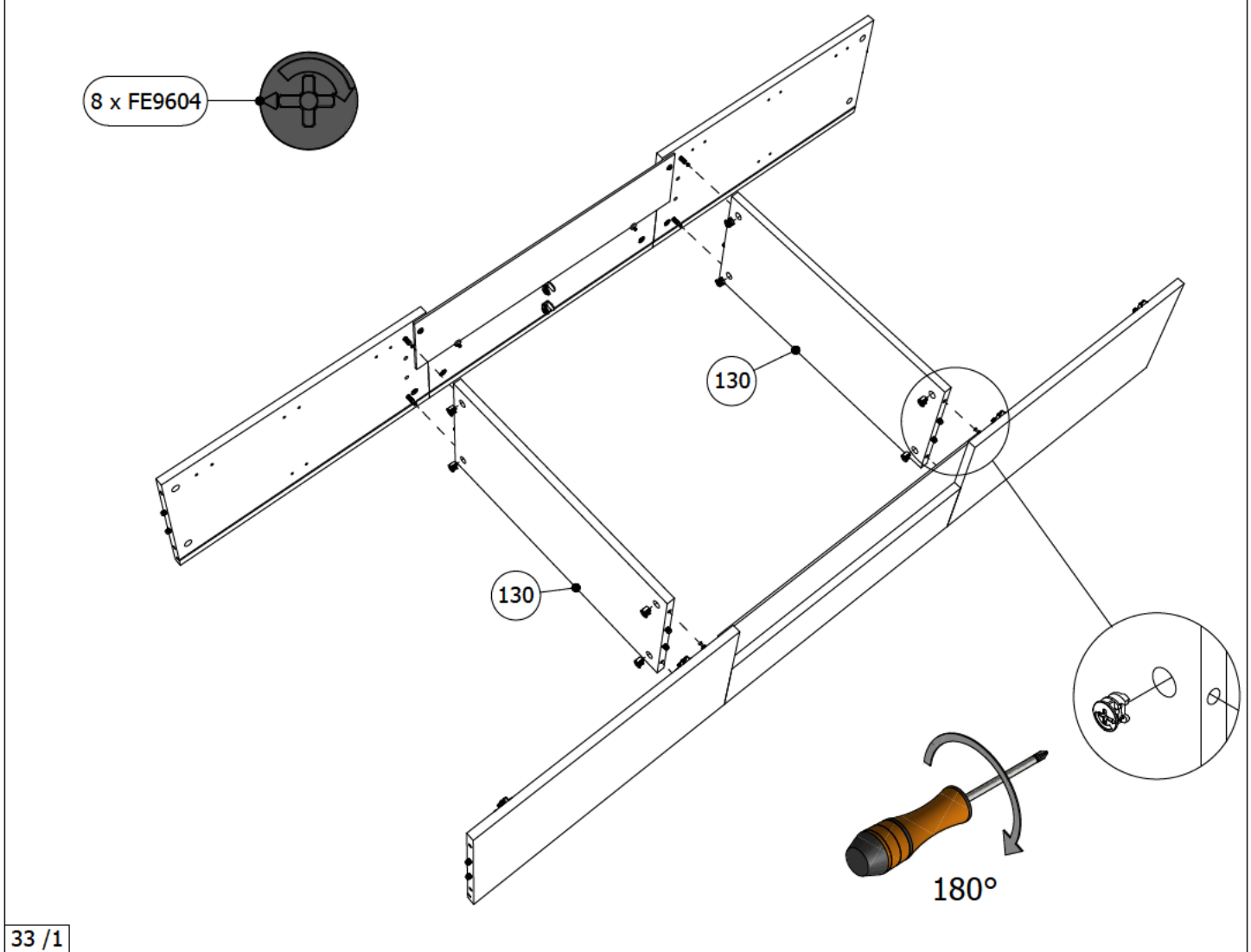
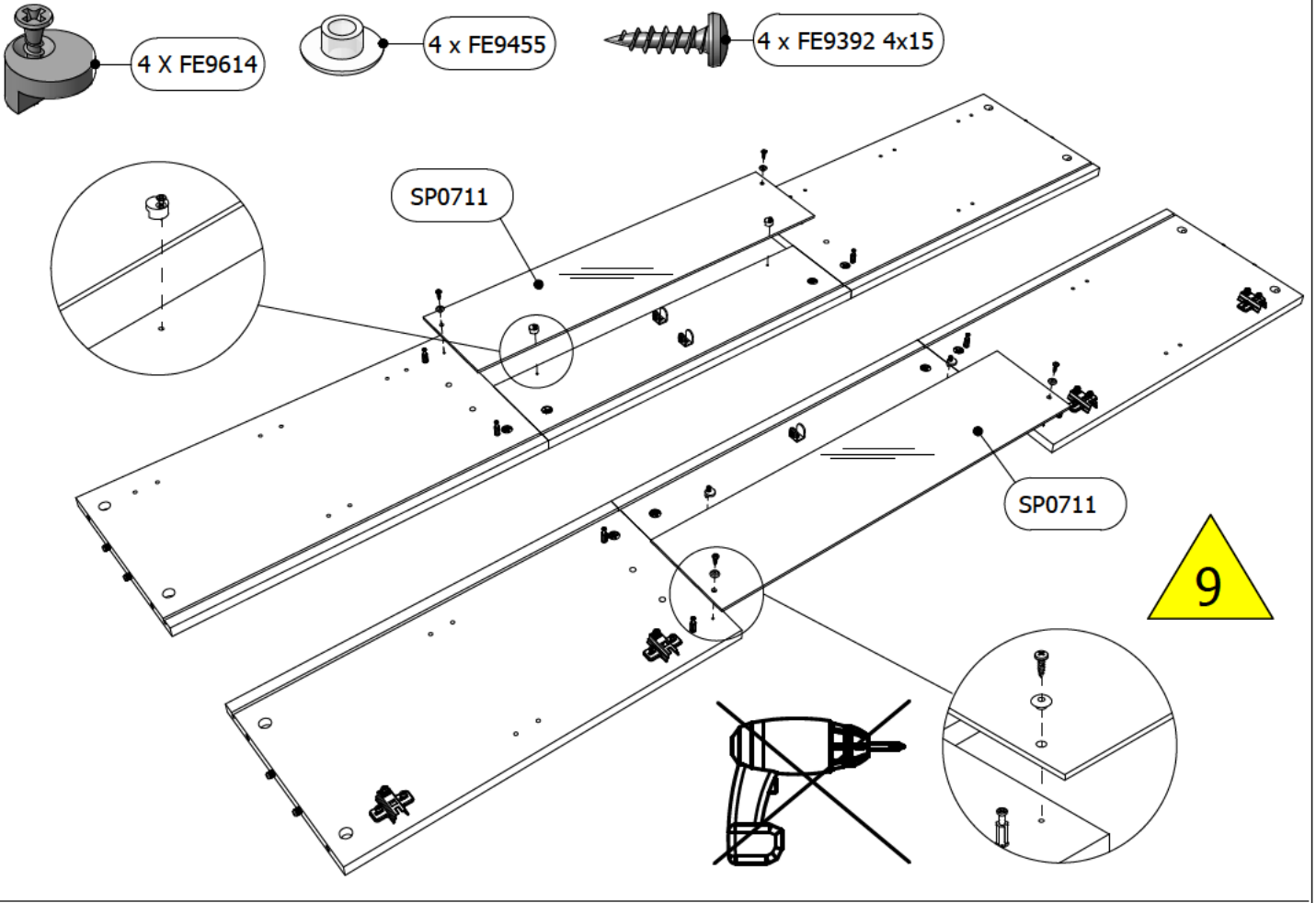



4 x FE9604

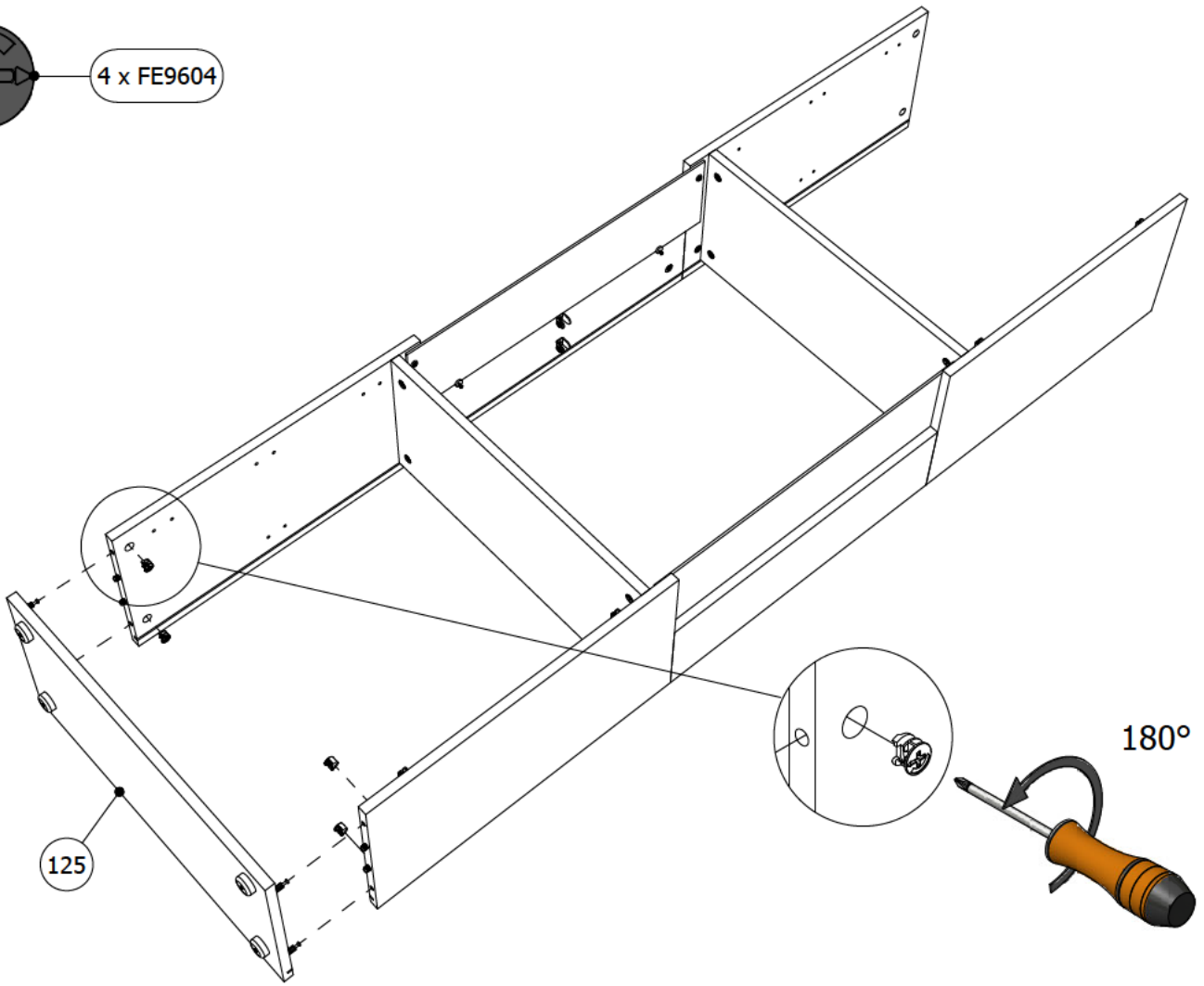

125

180°



4 x FE2429

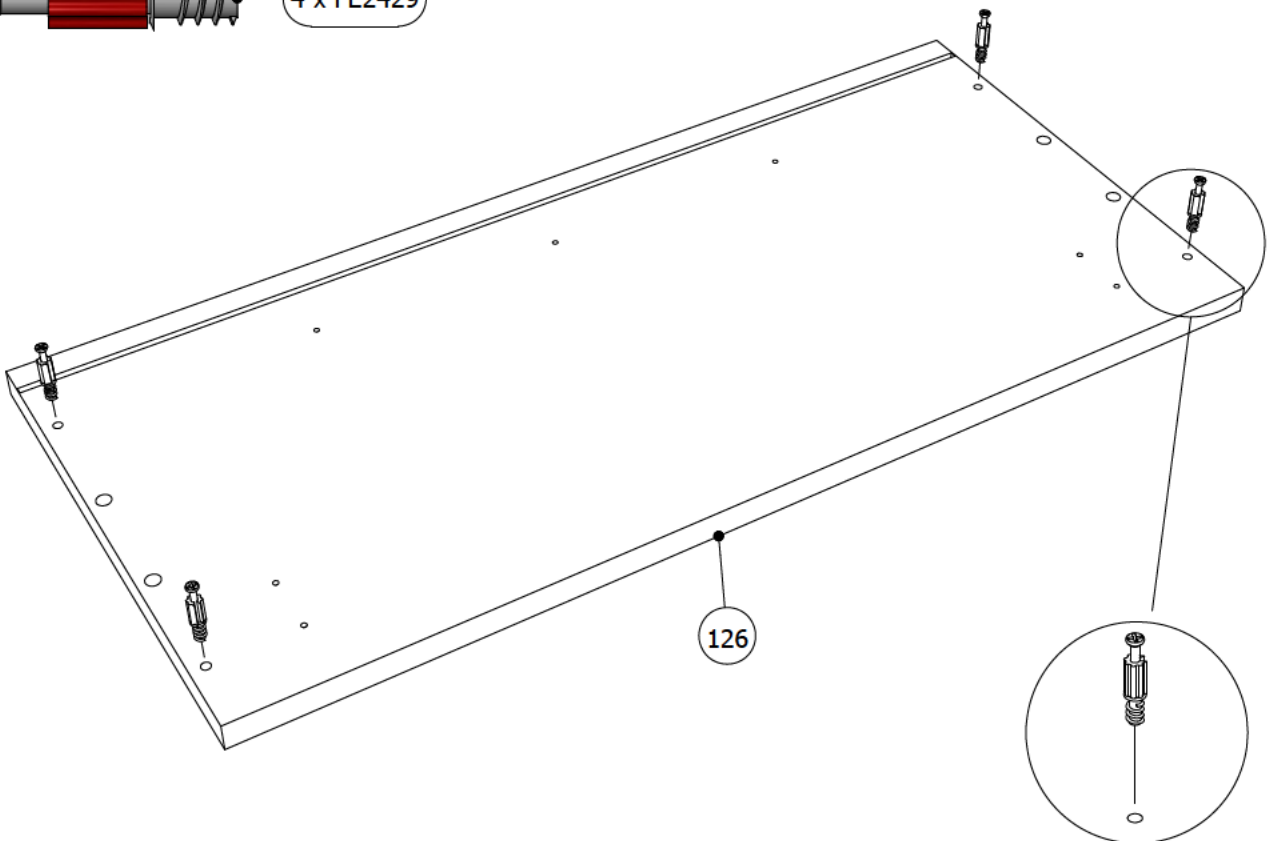

126

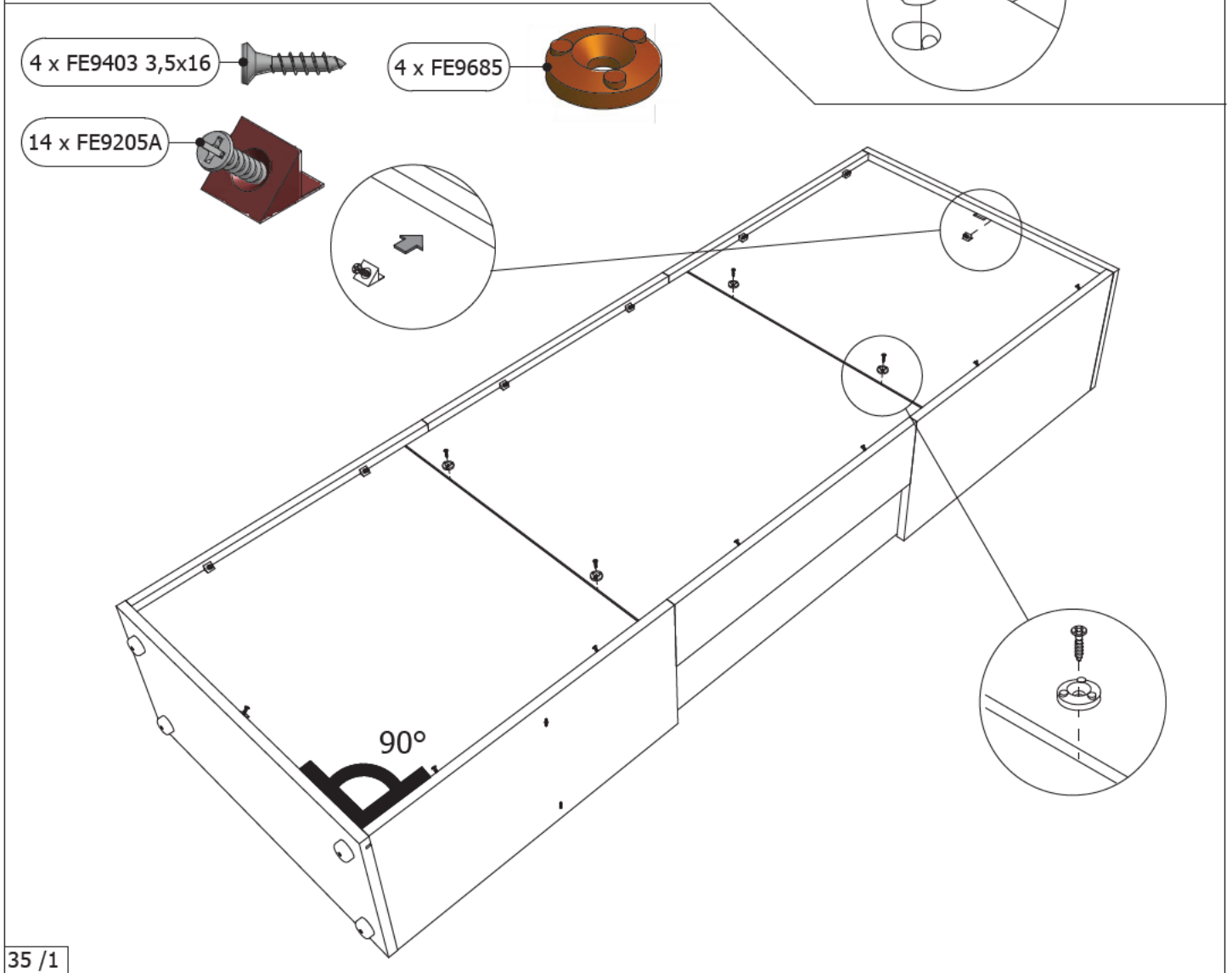
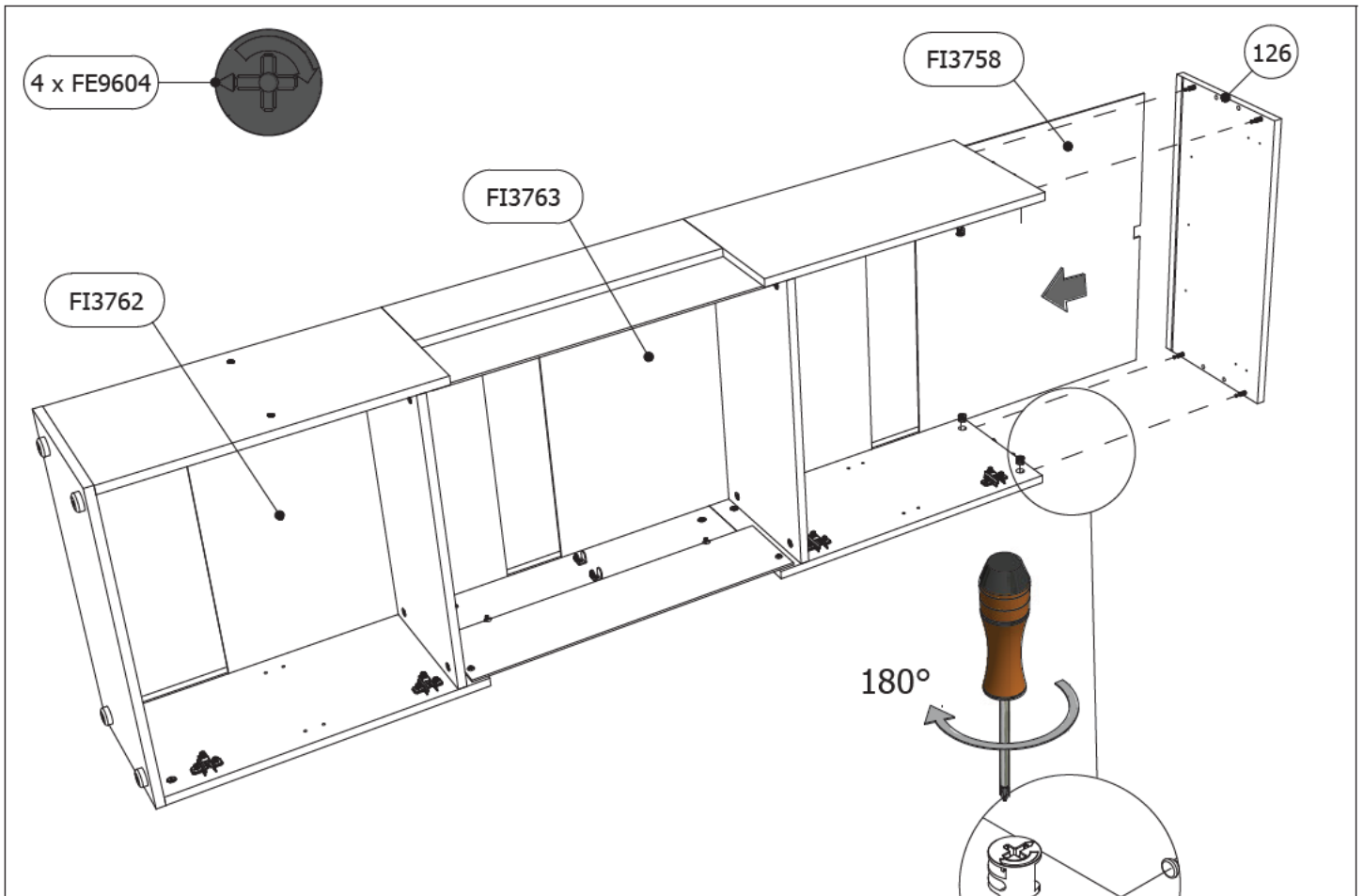

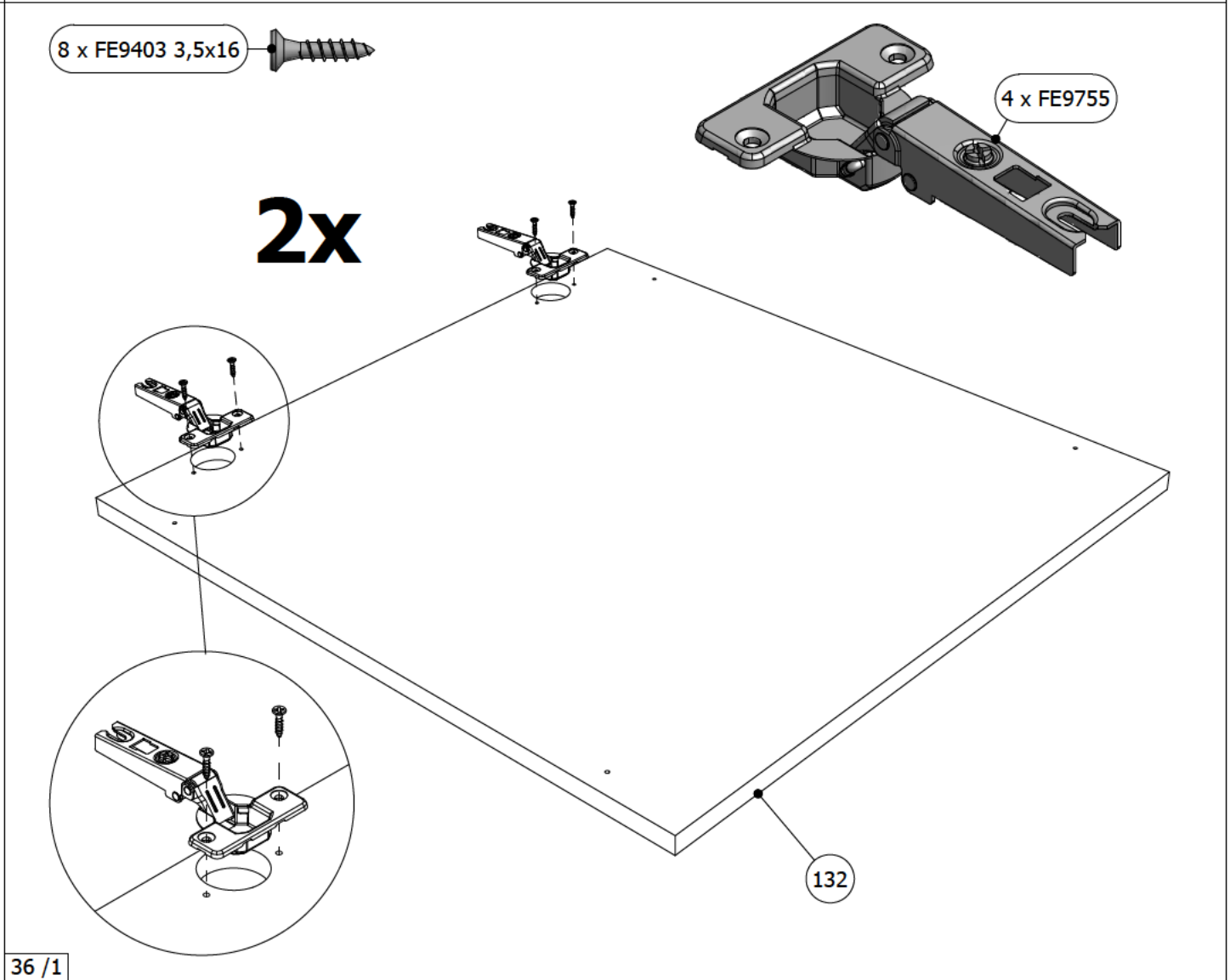
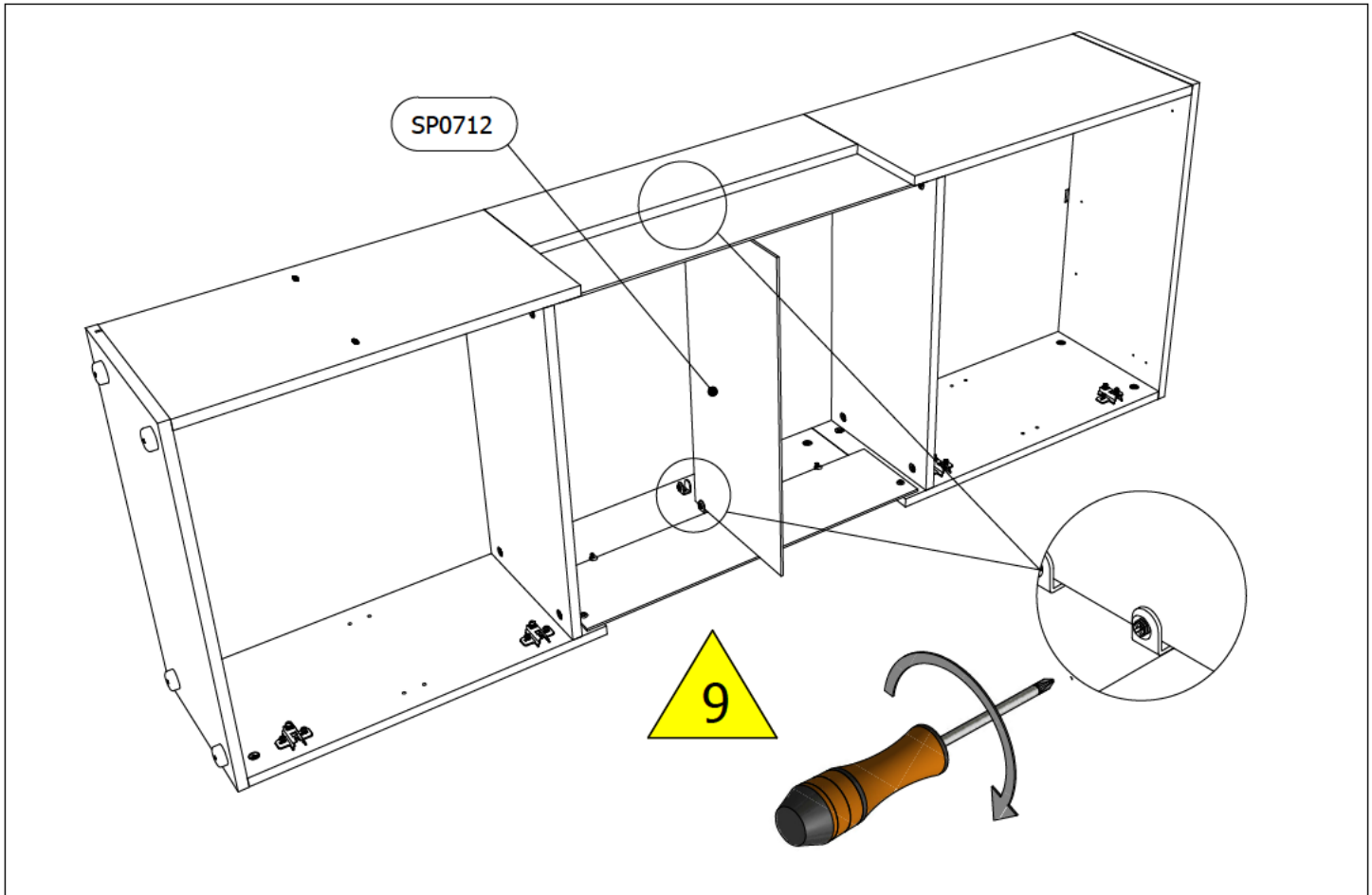

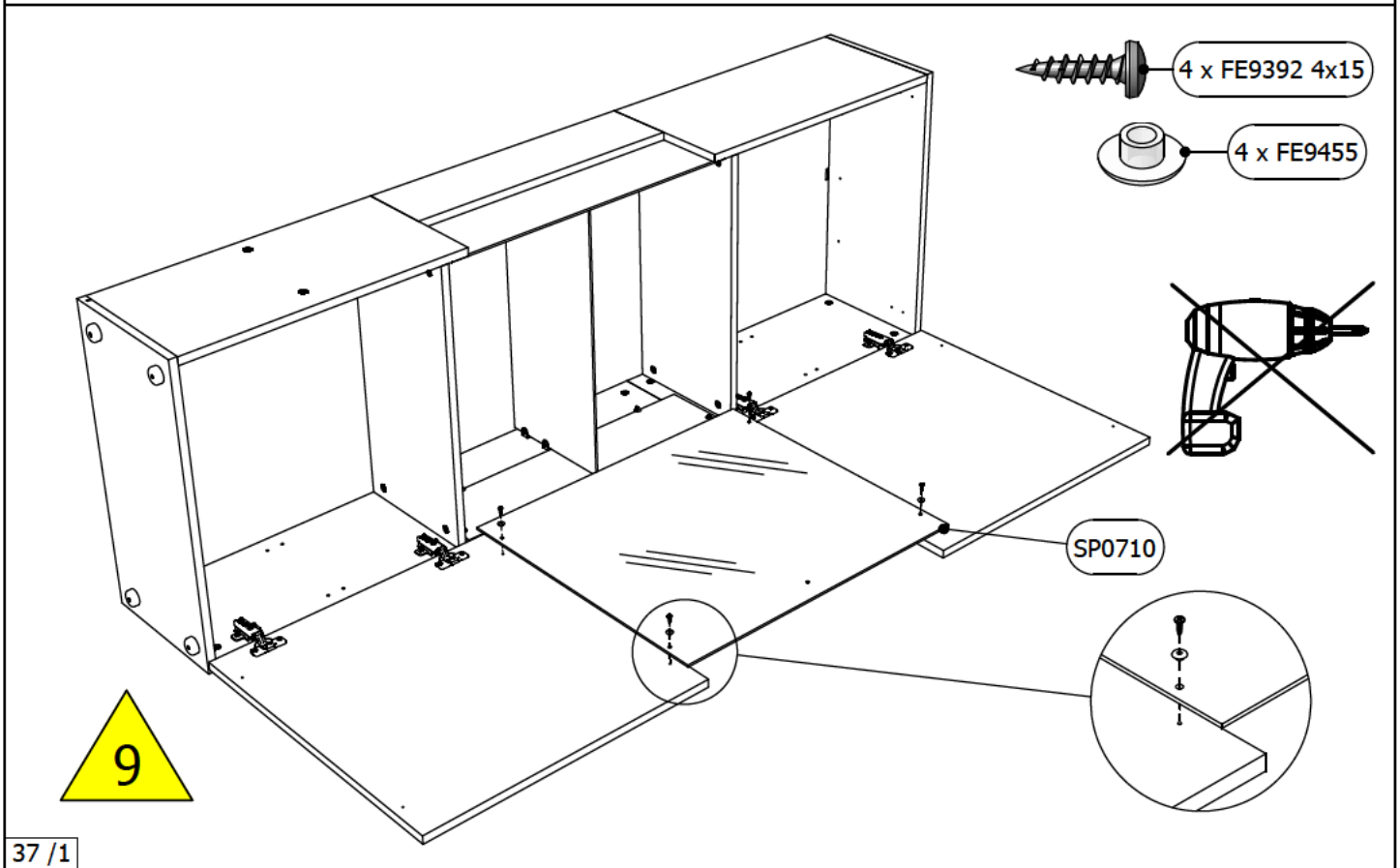
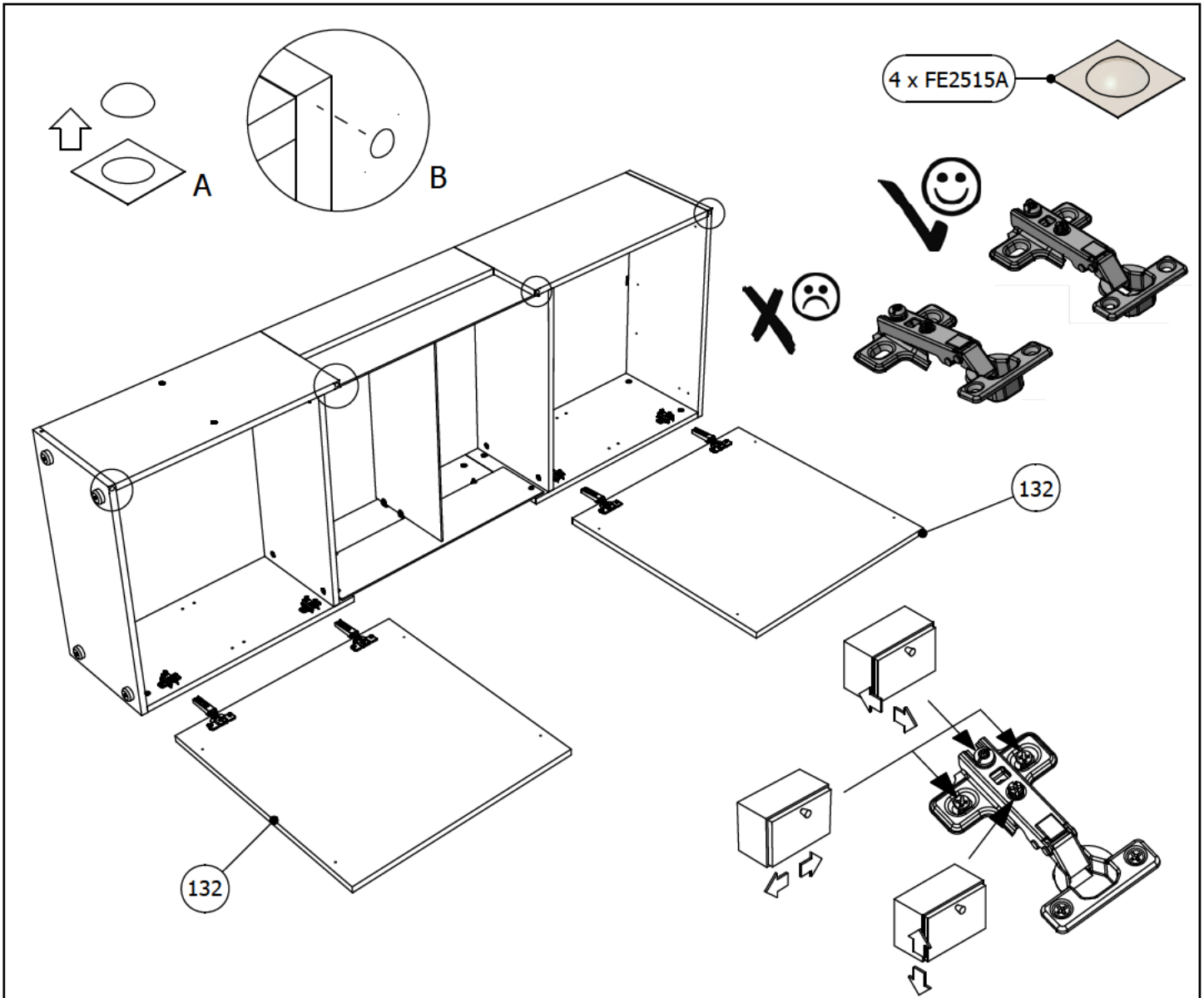

FE2258C

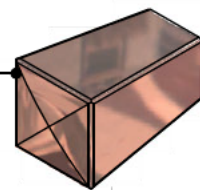

1 x FE9208 3,5x20



1 x FE9455

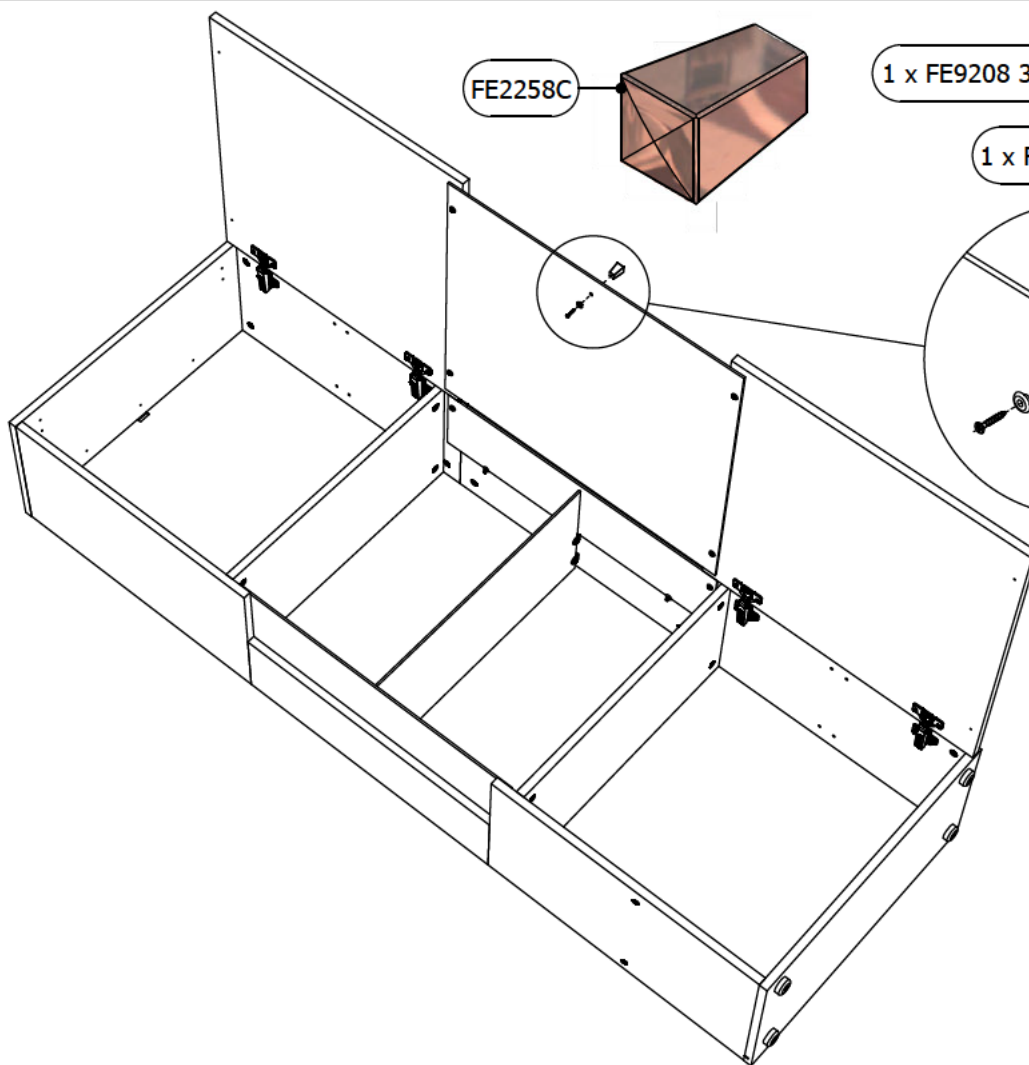

6 x FE2429



3 x FE2819

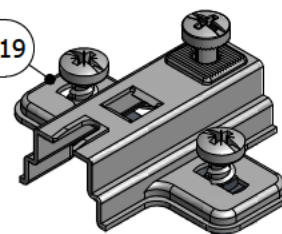

40

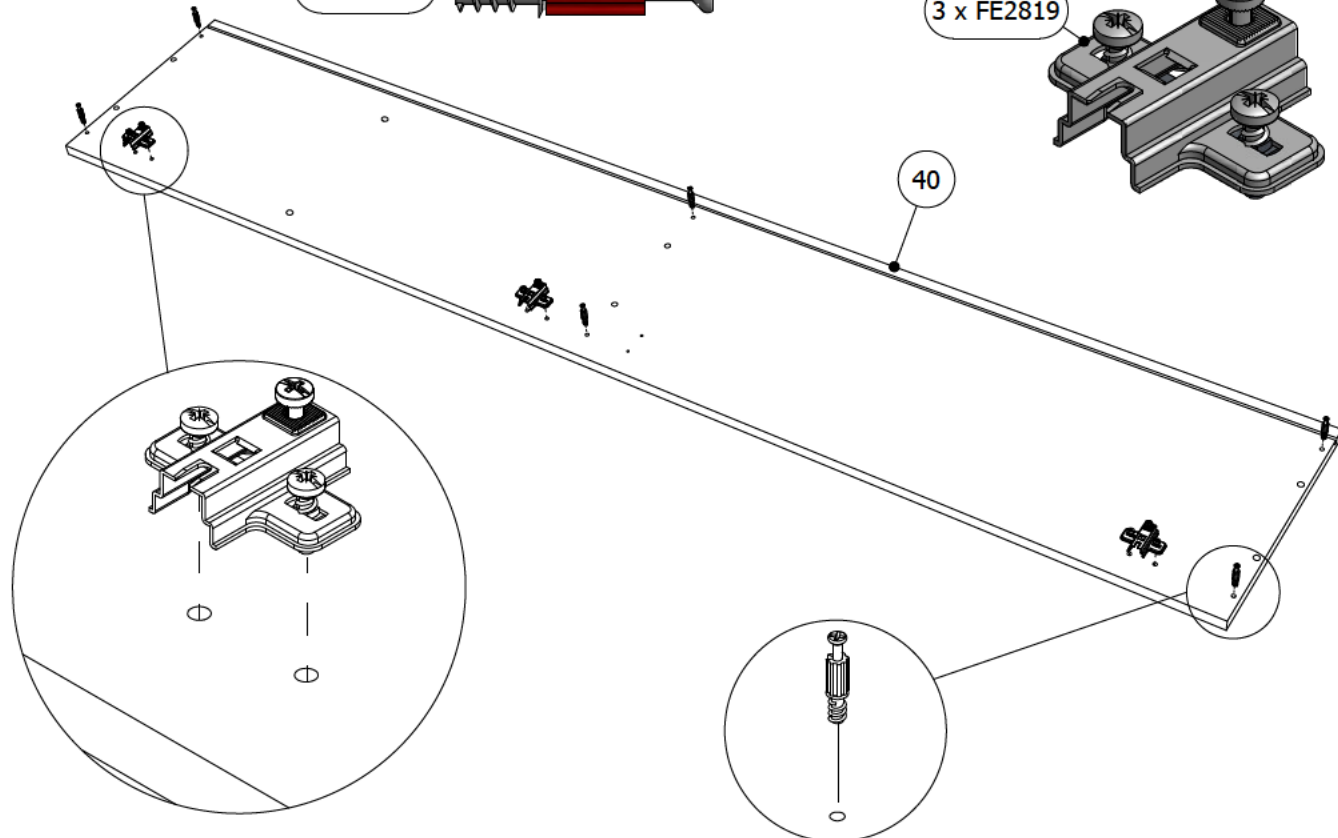

2 x FE2640 K12 - 120N

2 x A

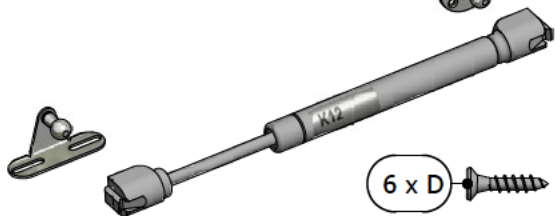

6 x D



8 x SPL001

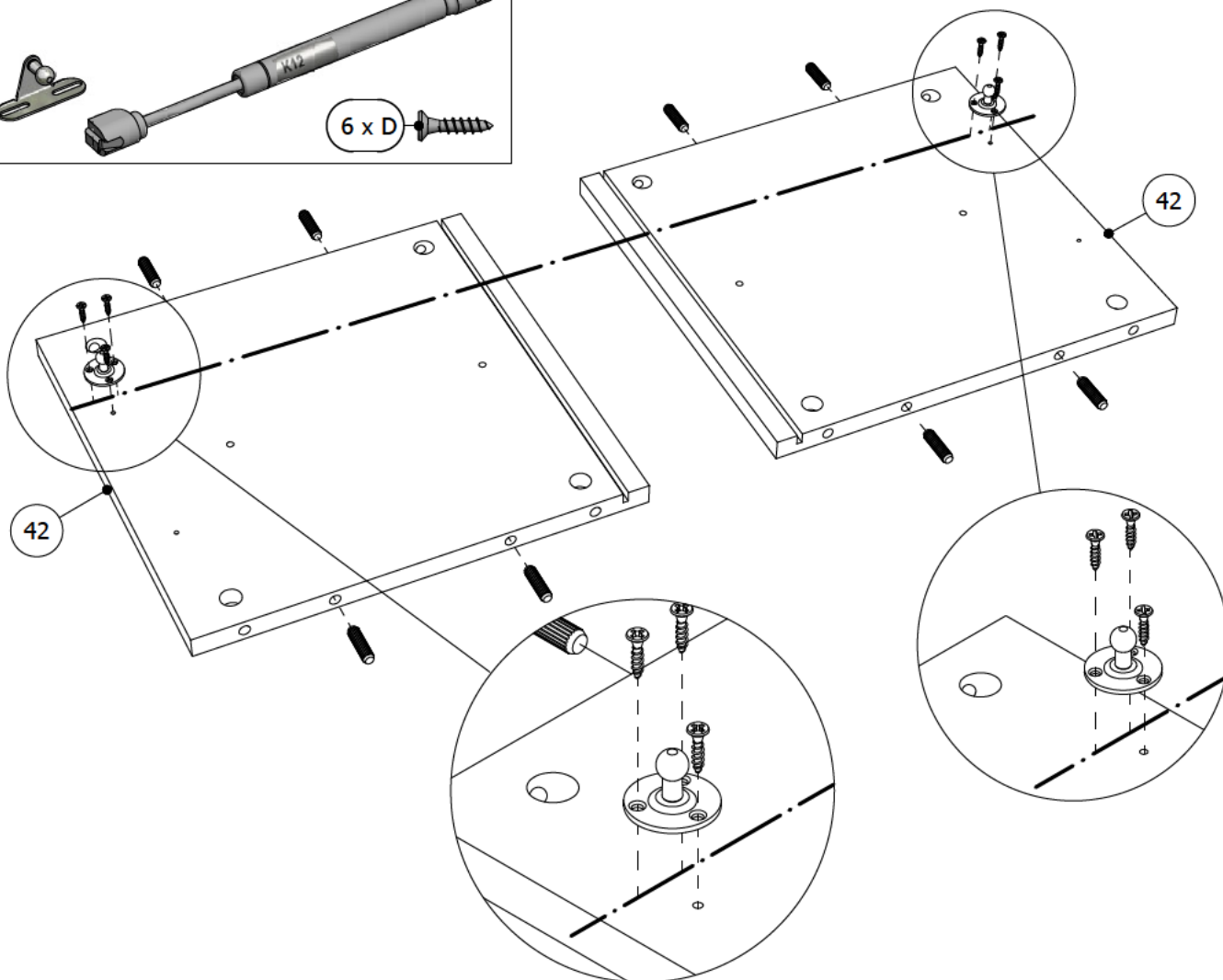

4 x SPL001

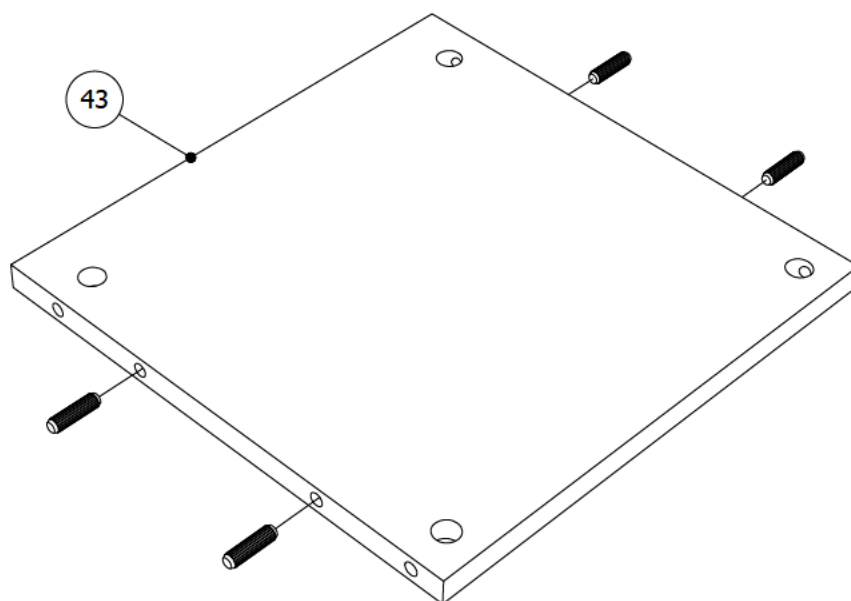

6 x FE9604

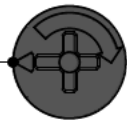

180°

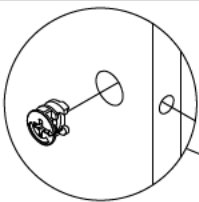

42

43

40

42

6 x FE2429



1 x FE2818

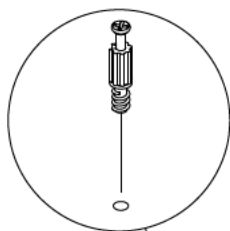
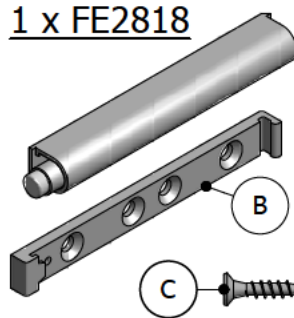

41

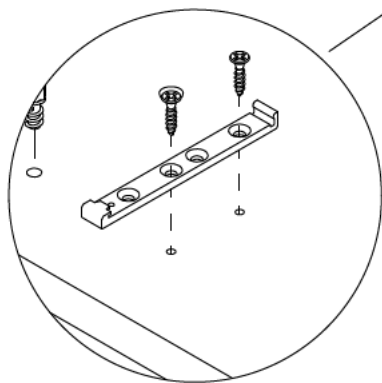

6 x FE9604

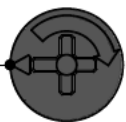

41

FI3759

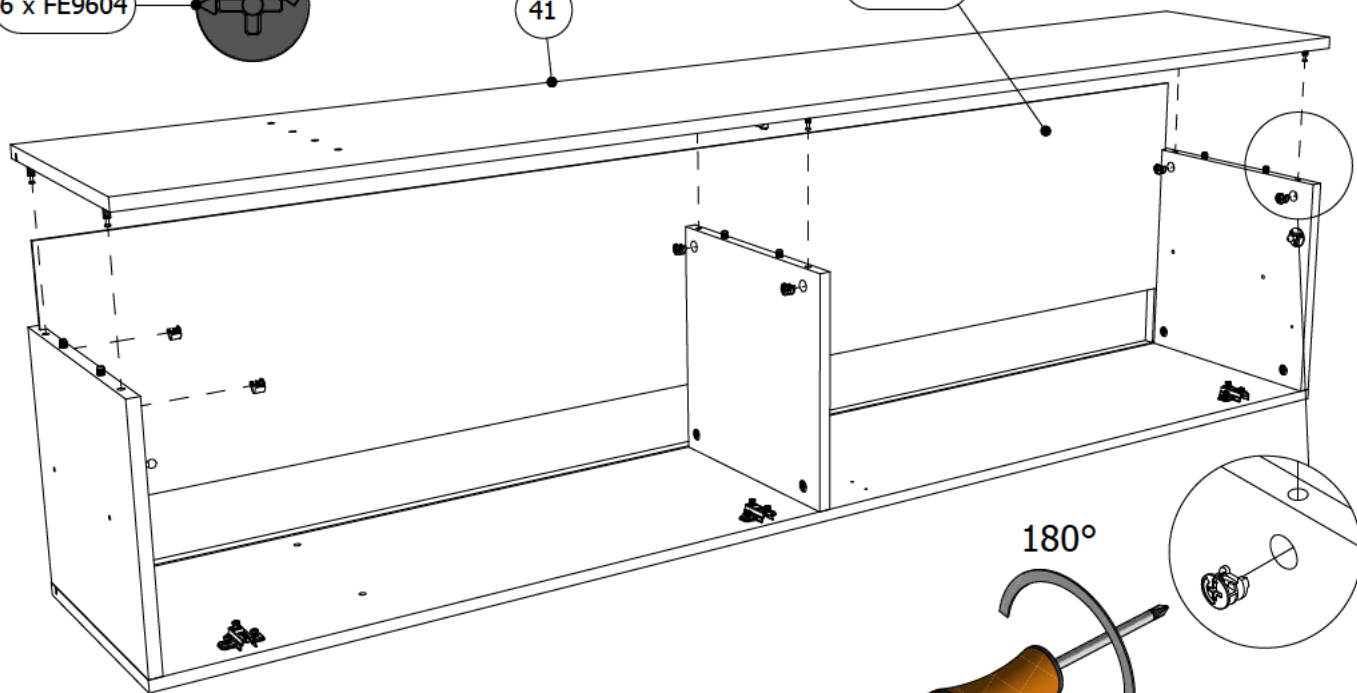

180°

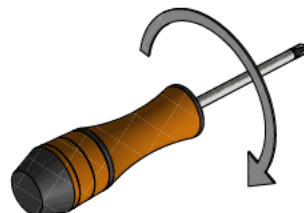

8 x SPL001



133

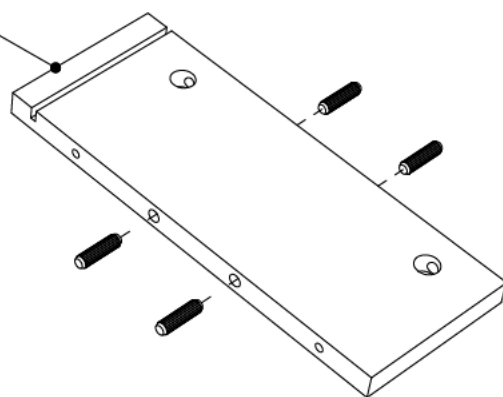

134

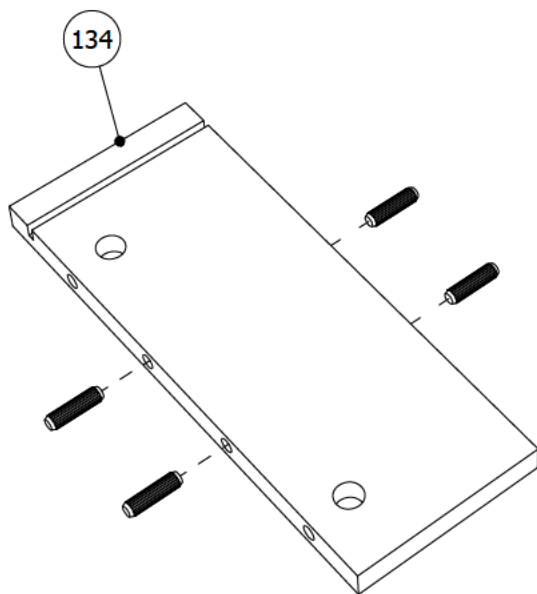

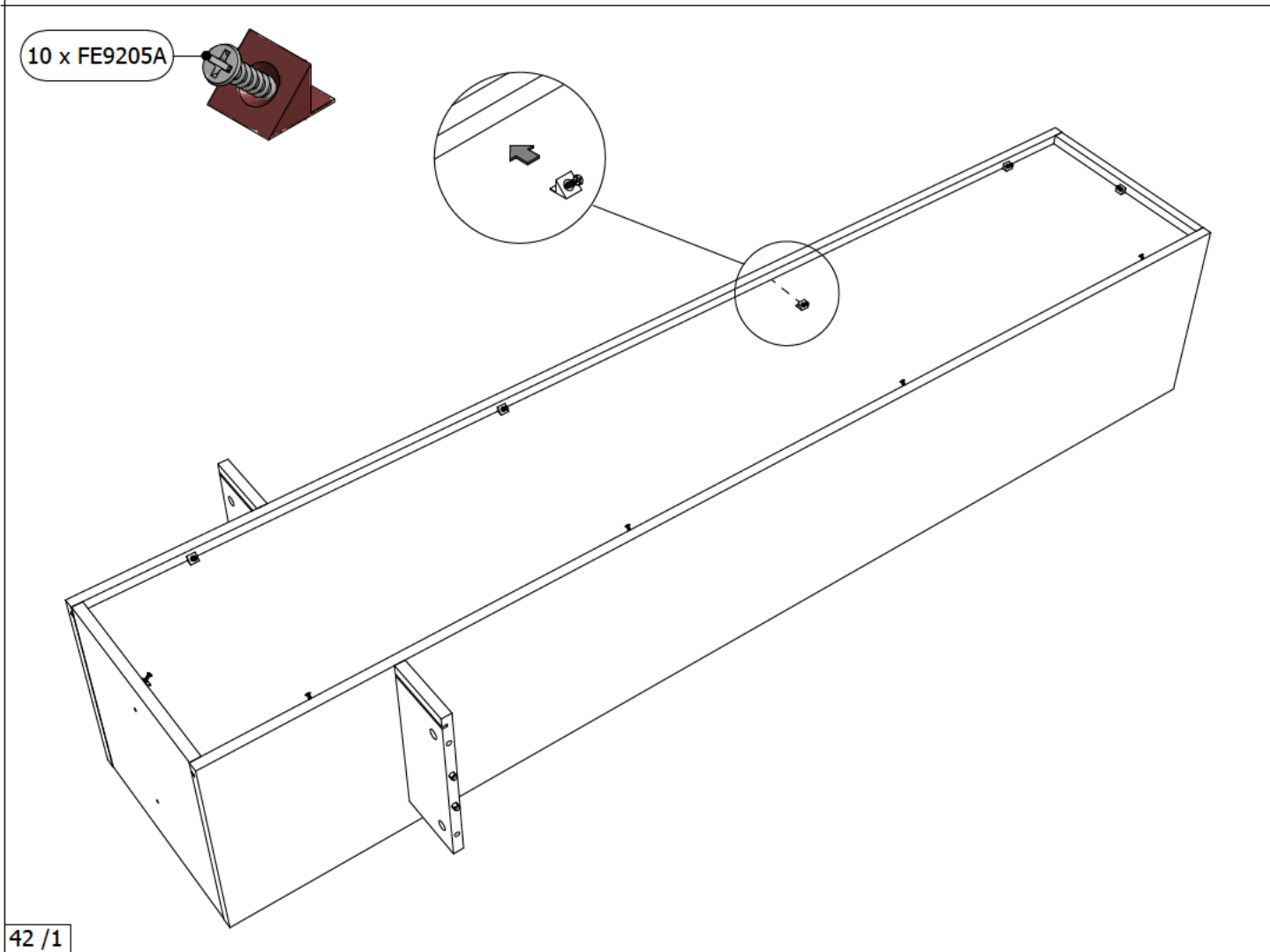
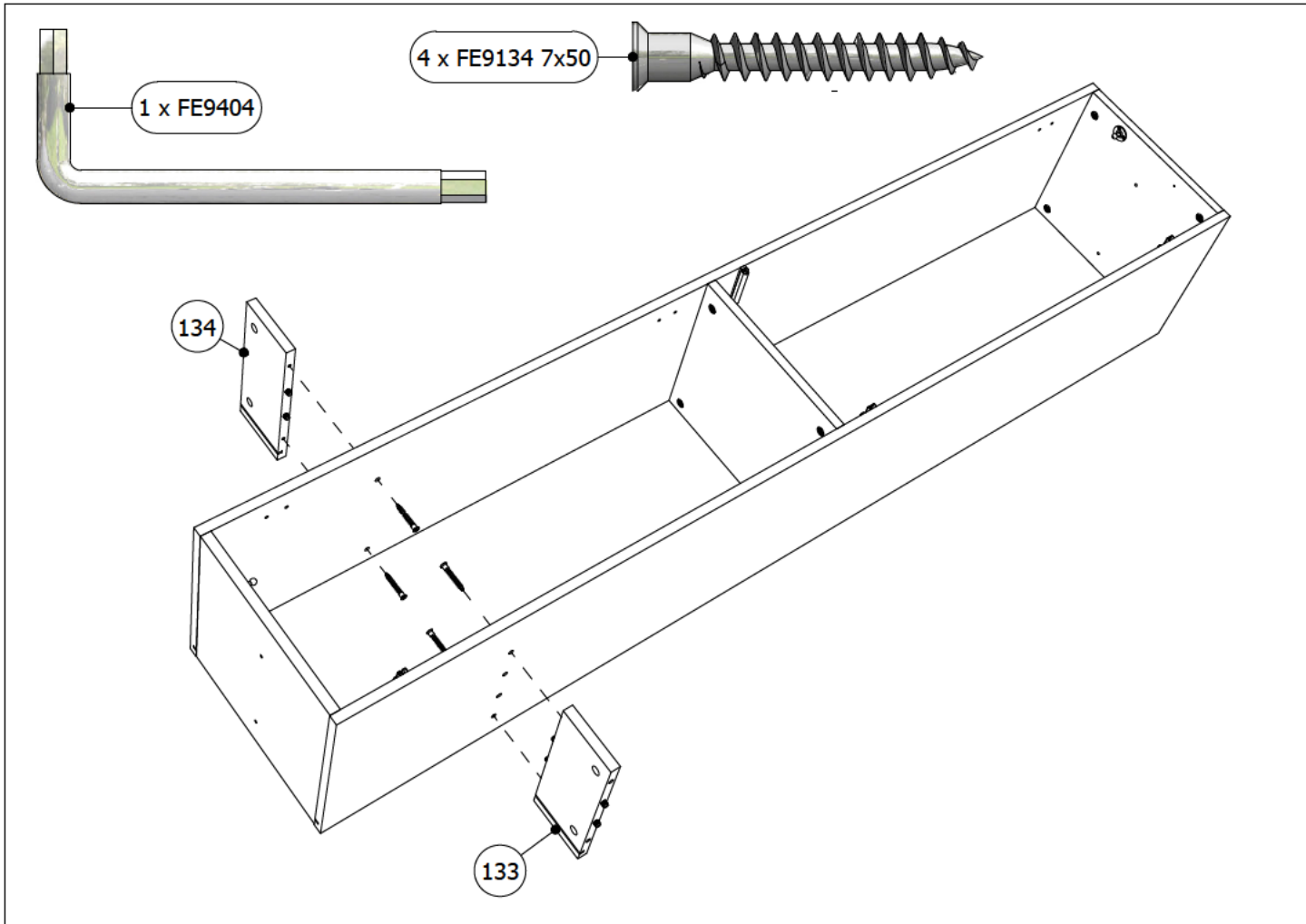

2 x FE9604

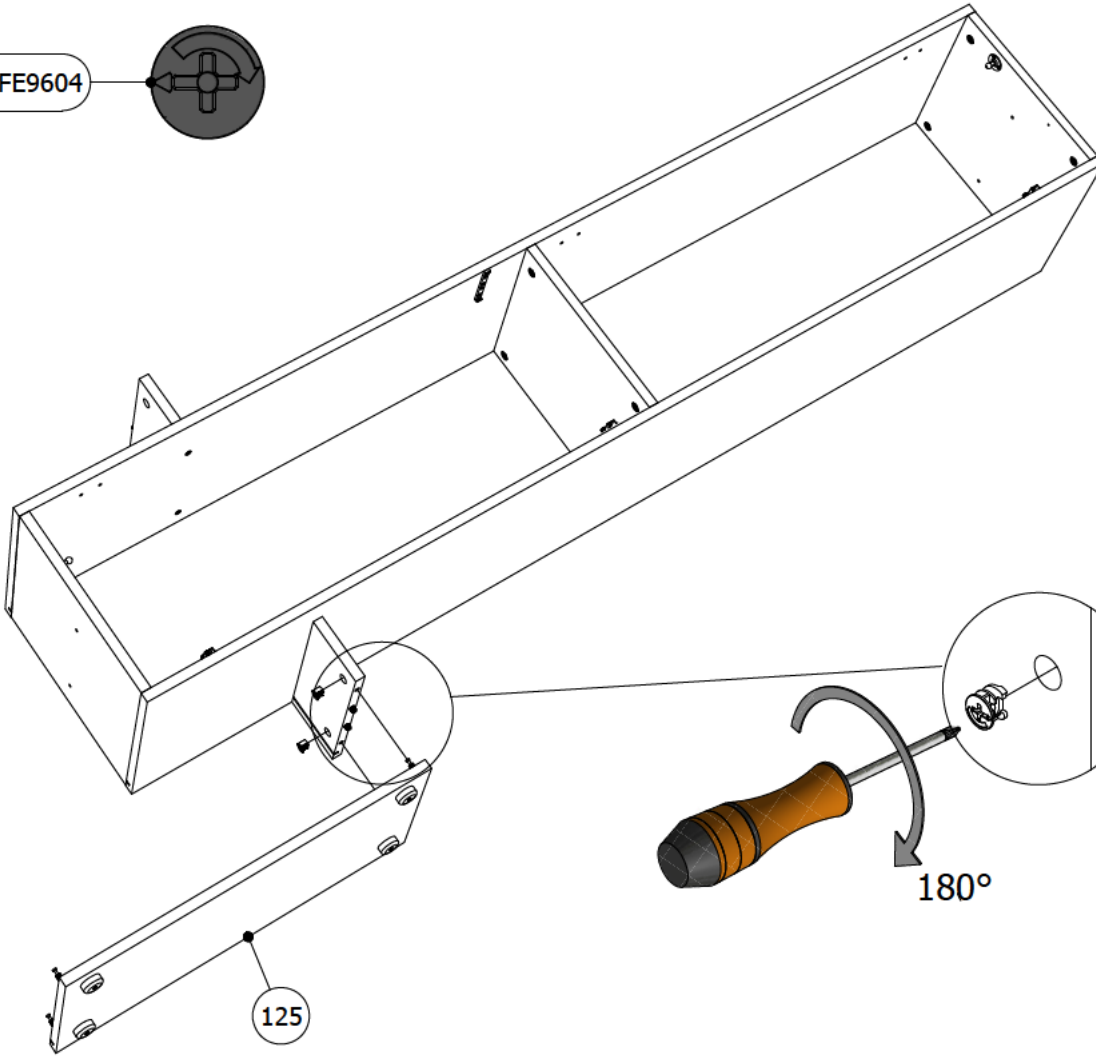
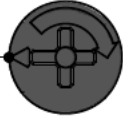

180°

2 x FE9696



2 x FE9302 4MAx22,5

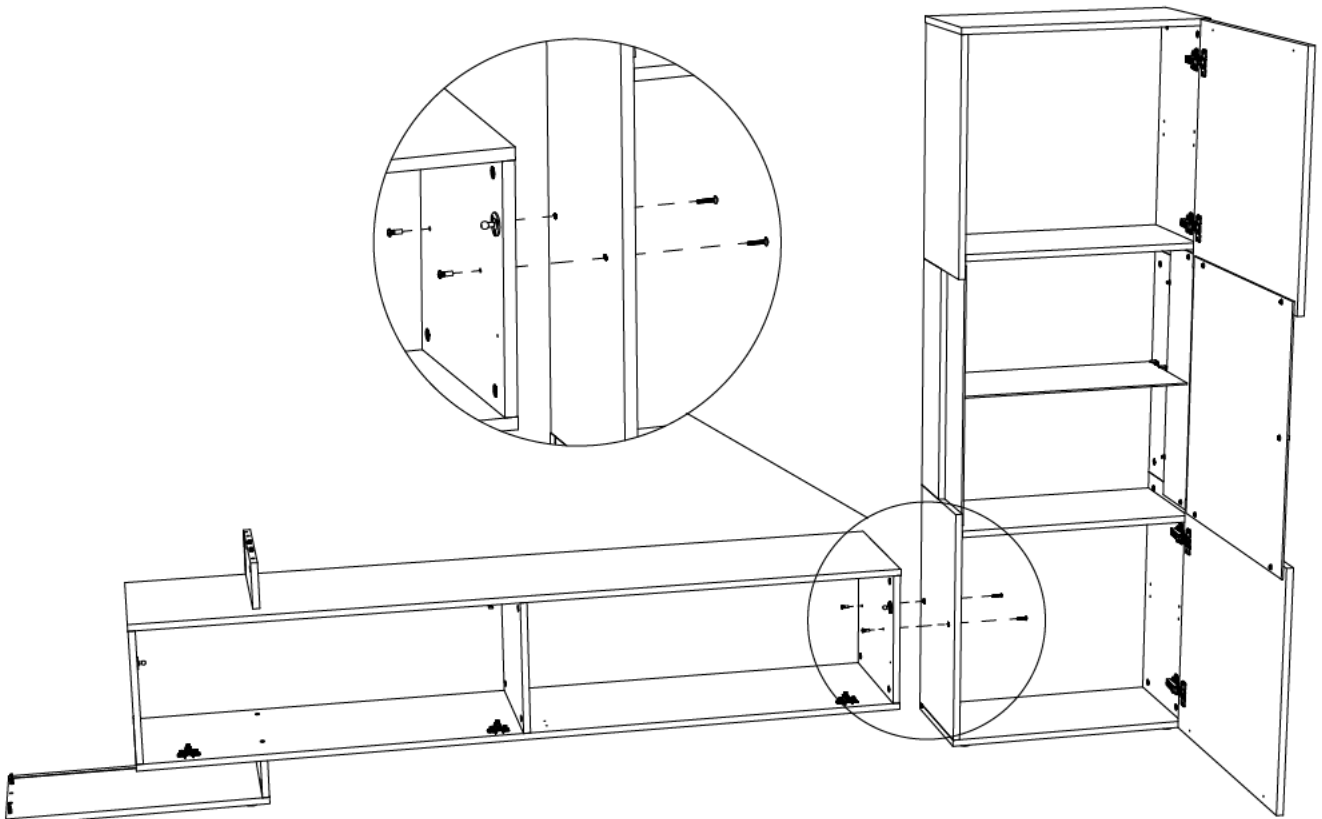

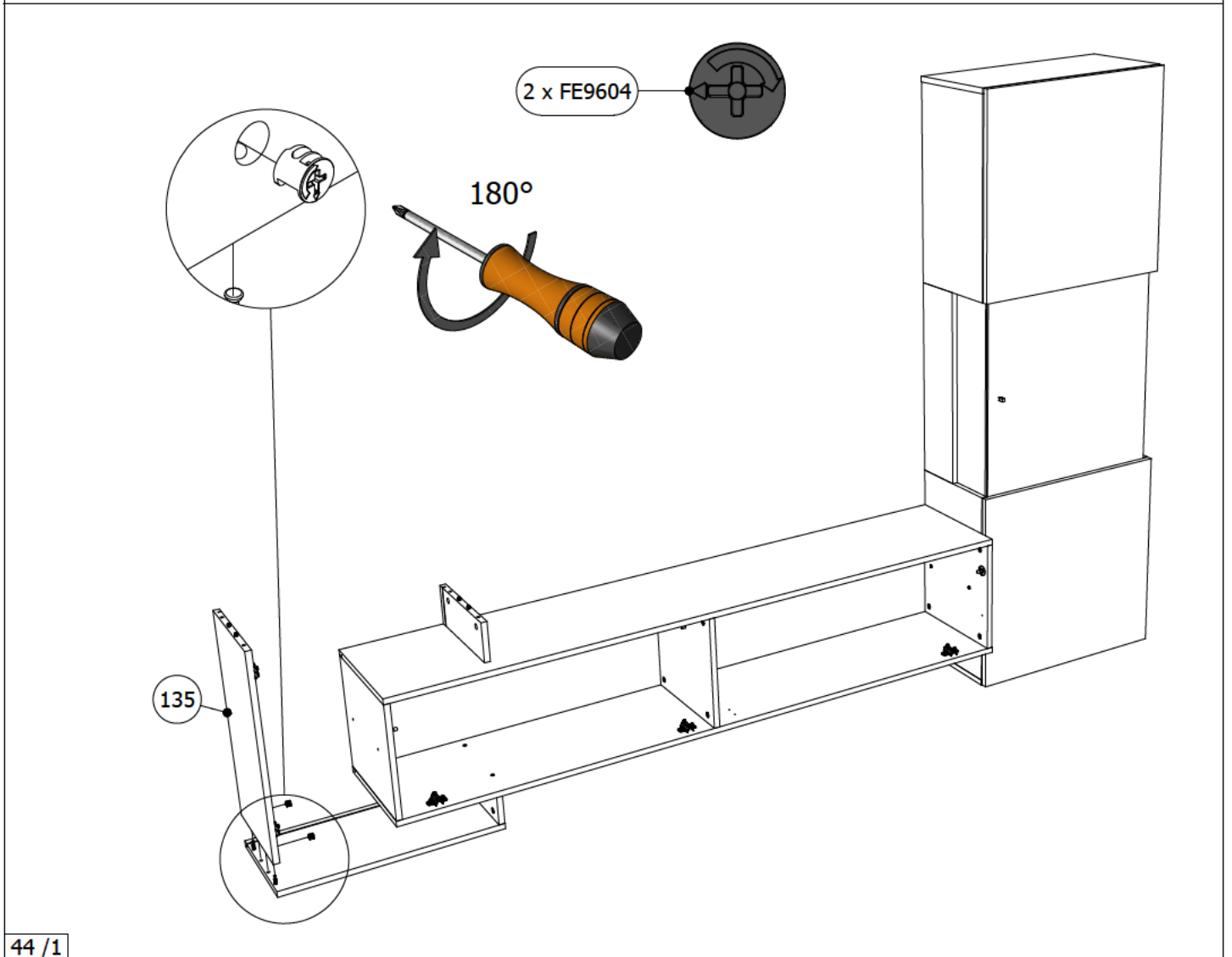
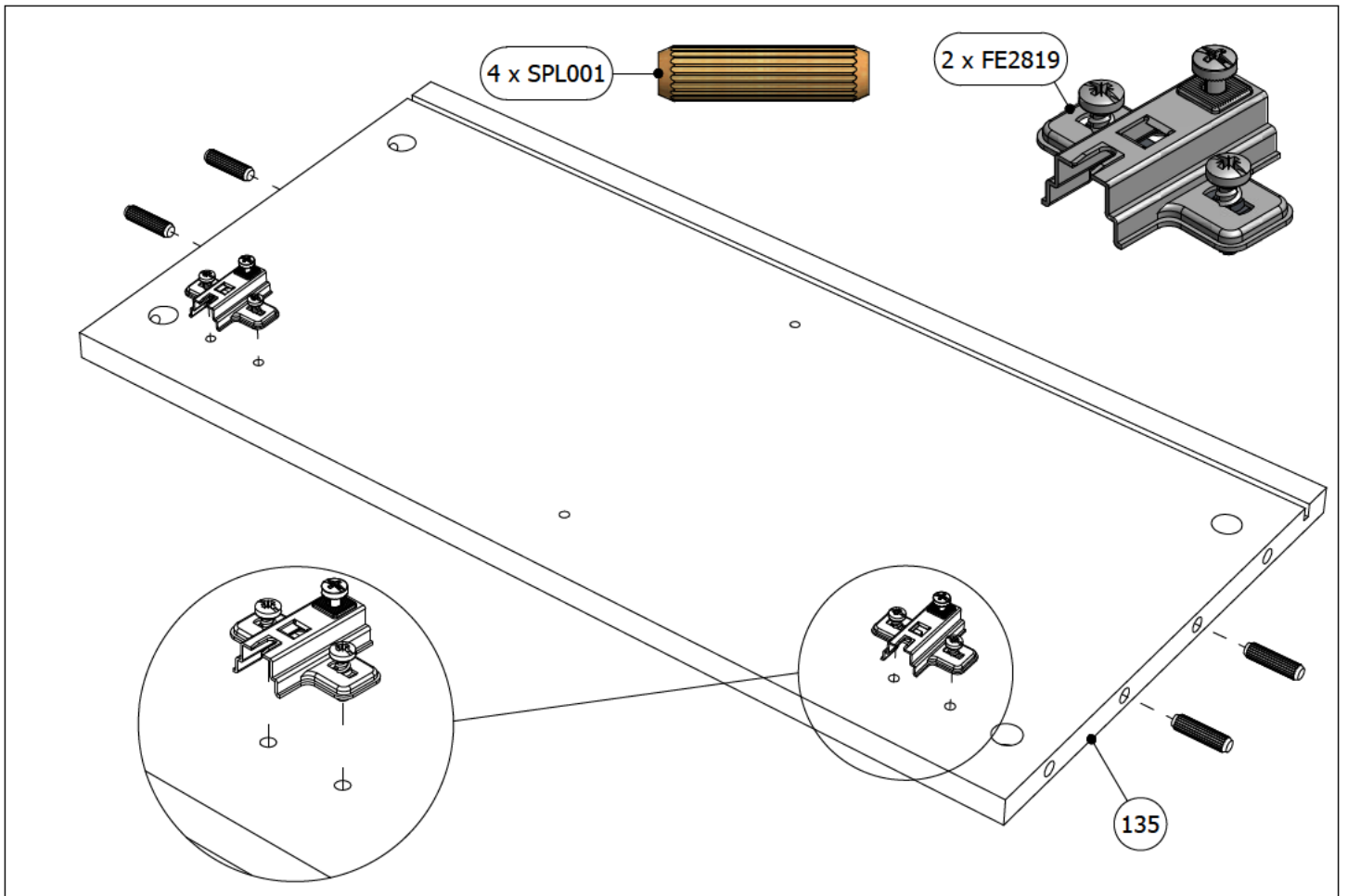

12 x FE2769

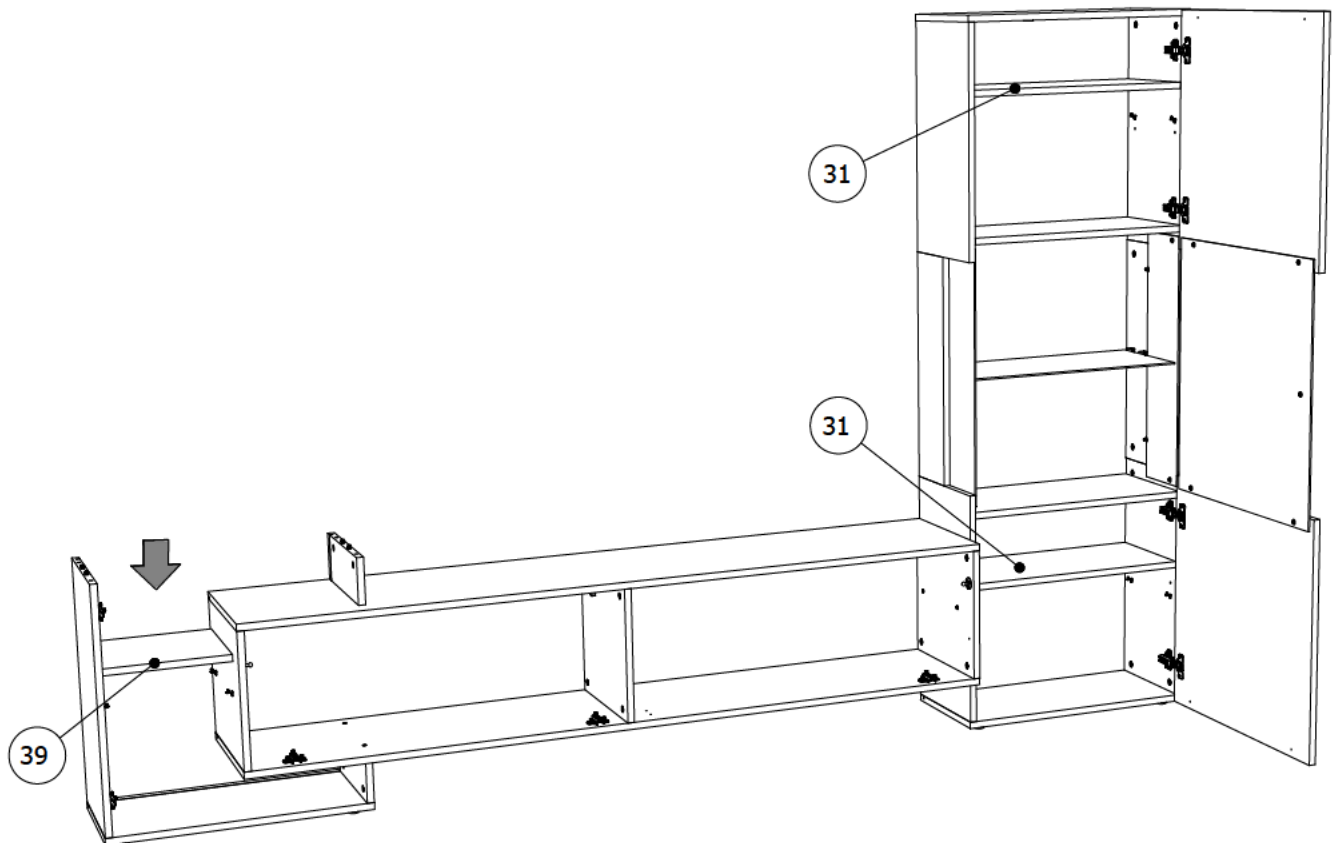
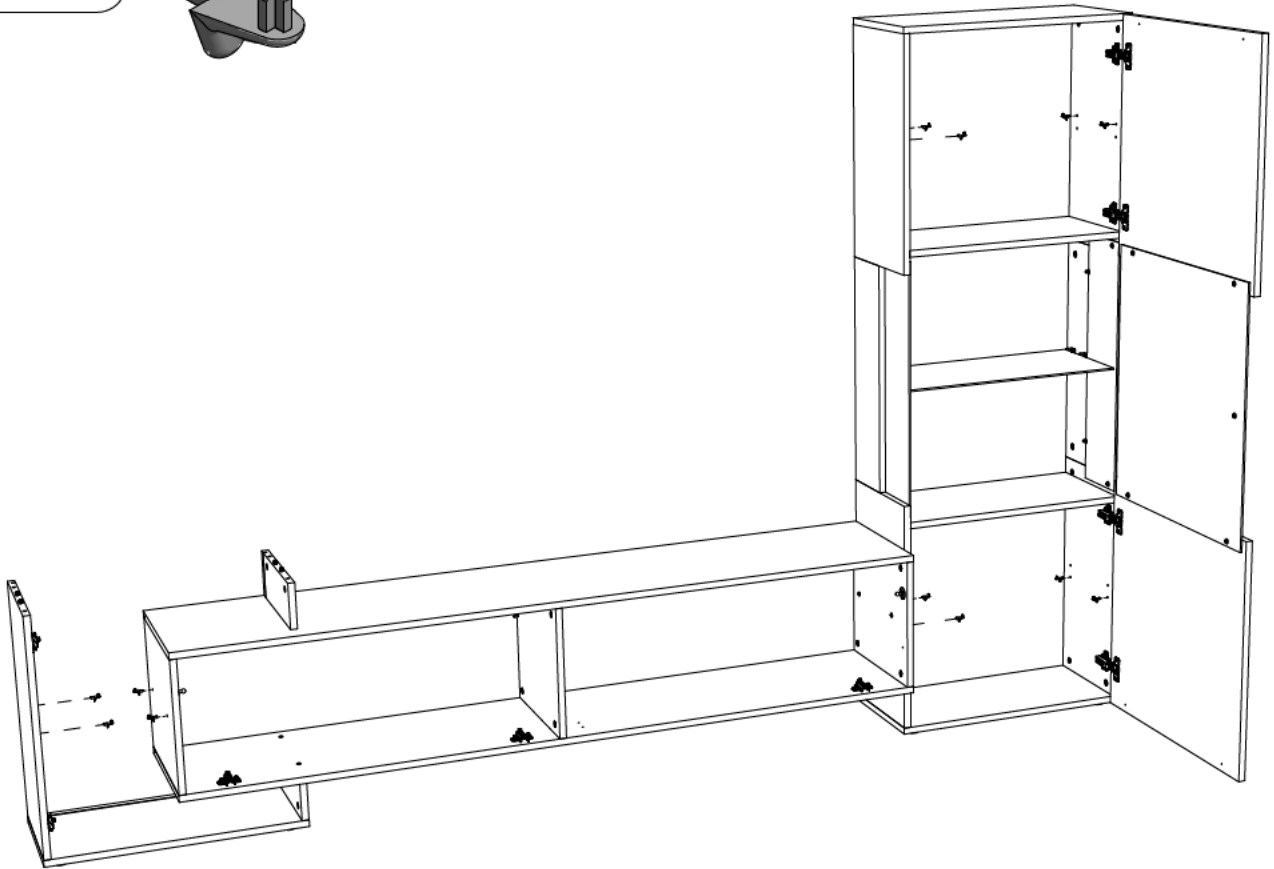

1 x FE2818

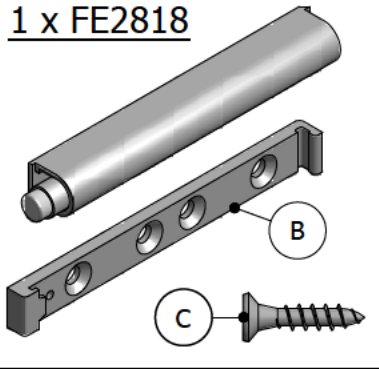

4 x FE2429

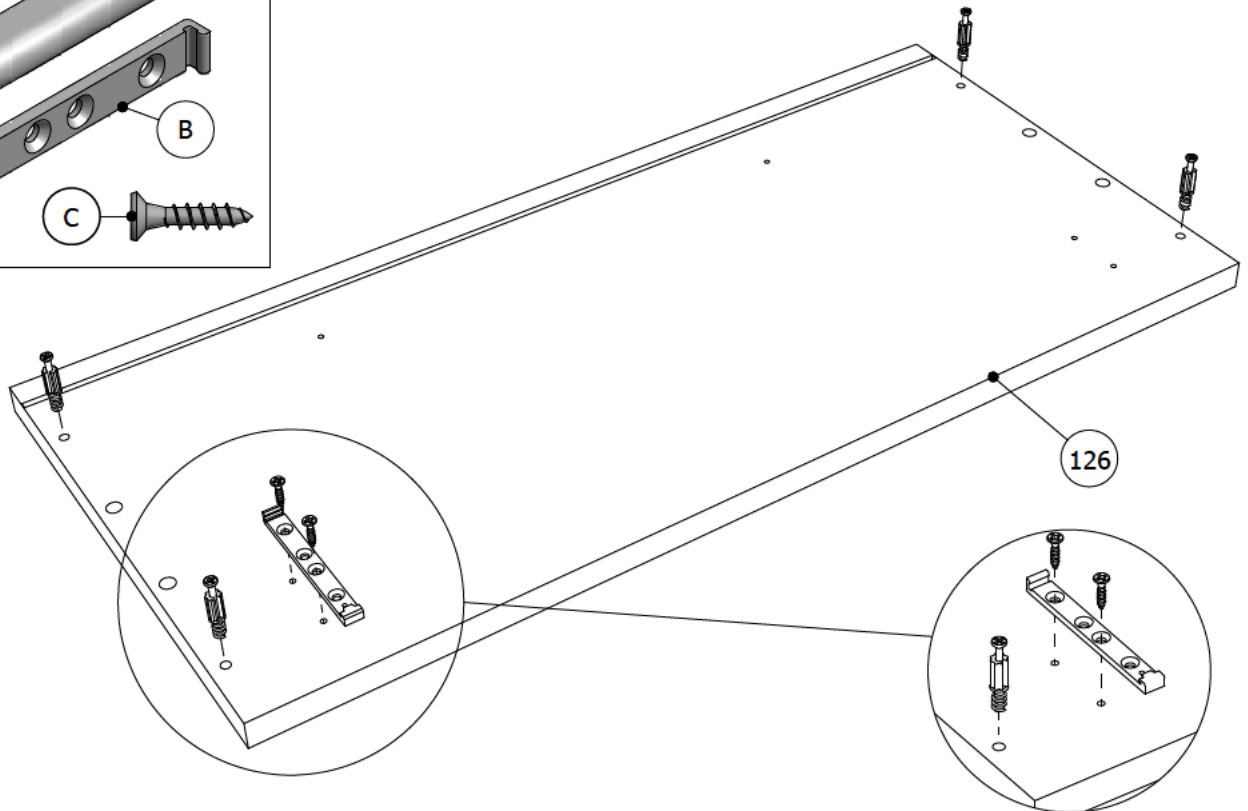
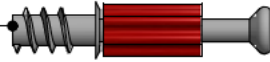

4 x FE9604

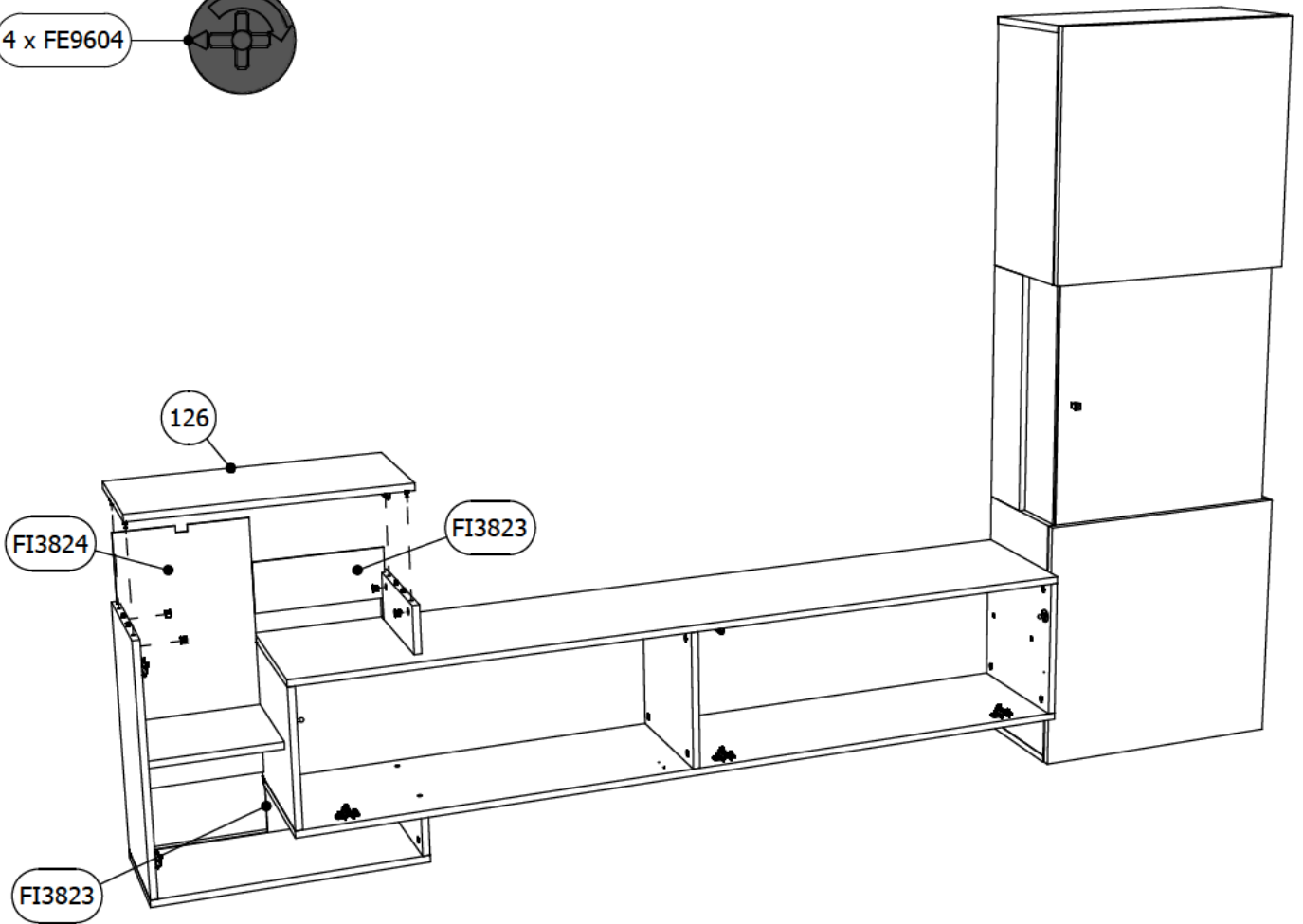
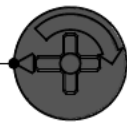

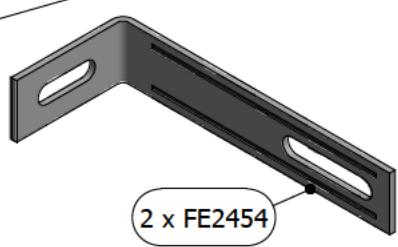
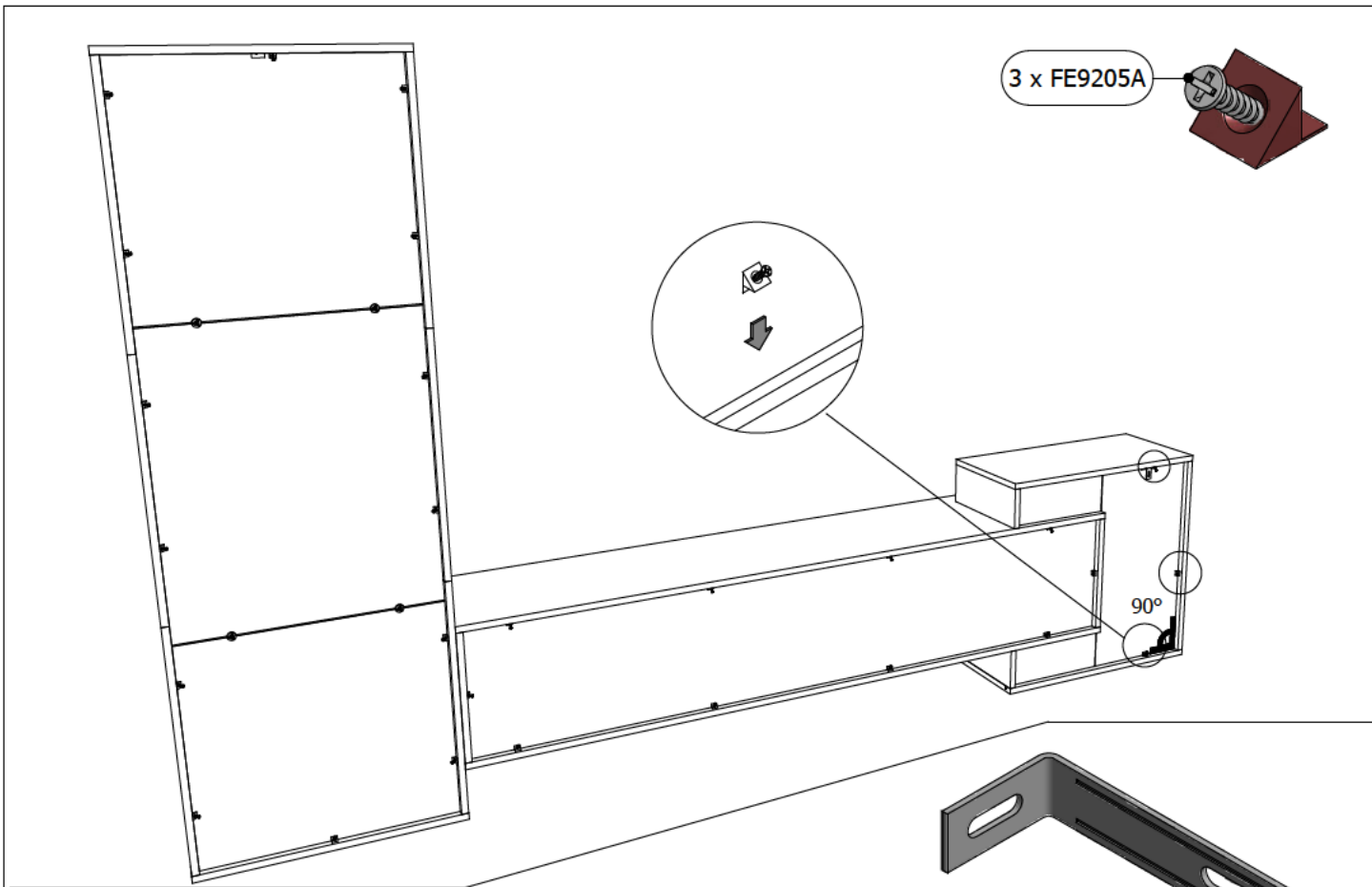

270 cm

30 cm

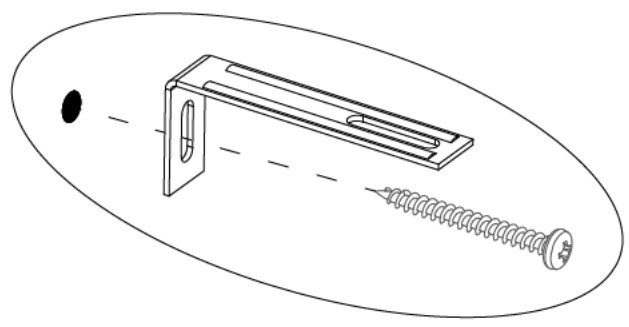

15,5 cm

57,8 cm

171,5 cm

2 x FE9392 4x15

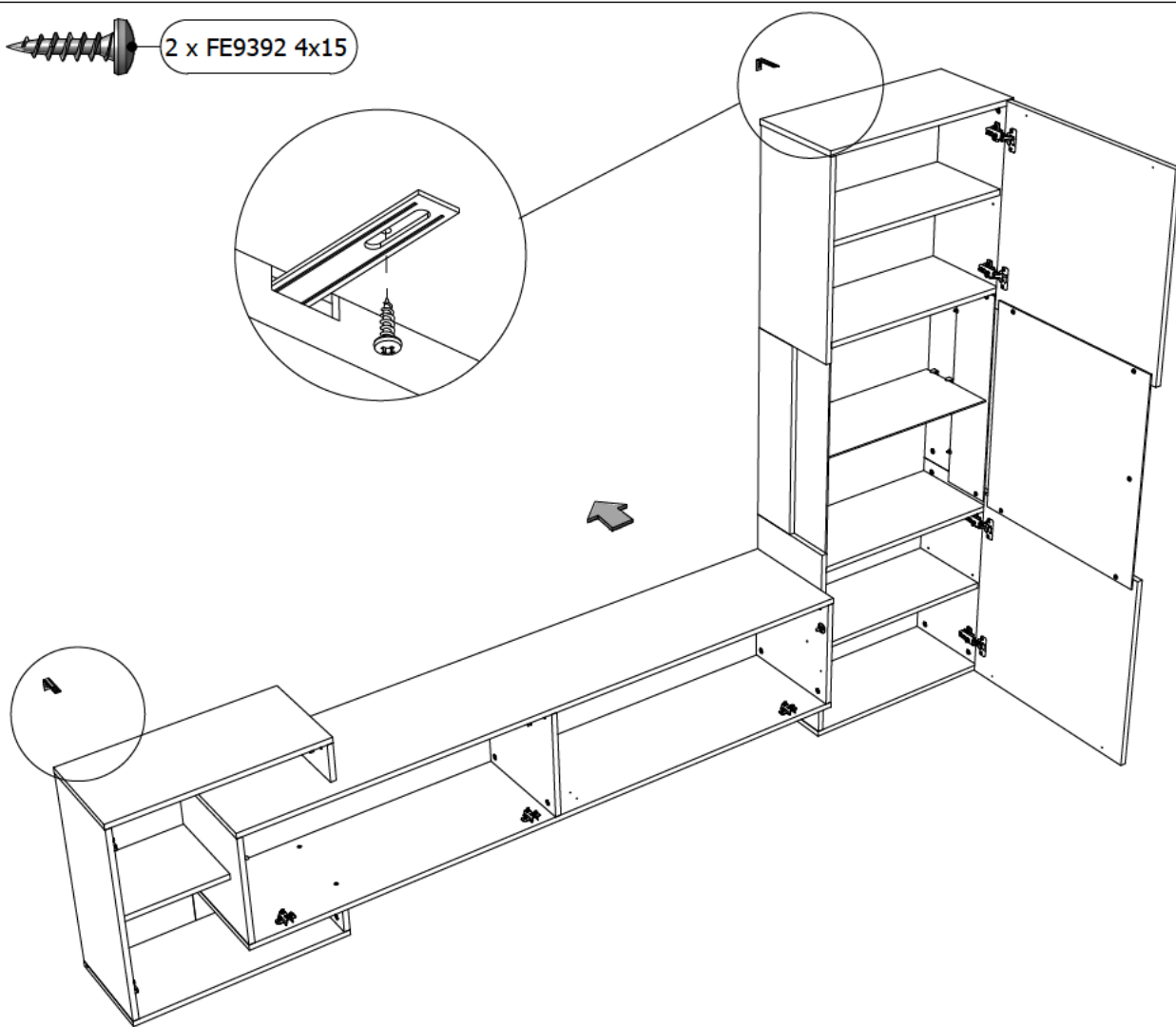

4 x FE9403 3,5x16

2 x FE9755

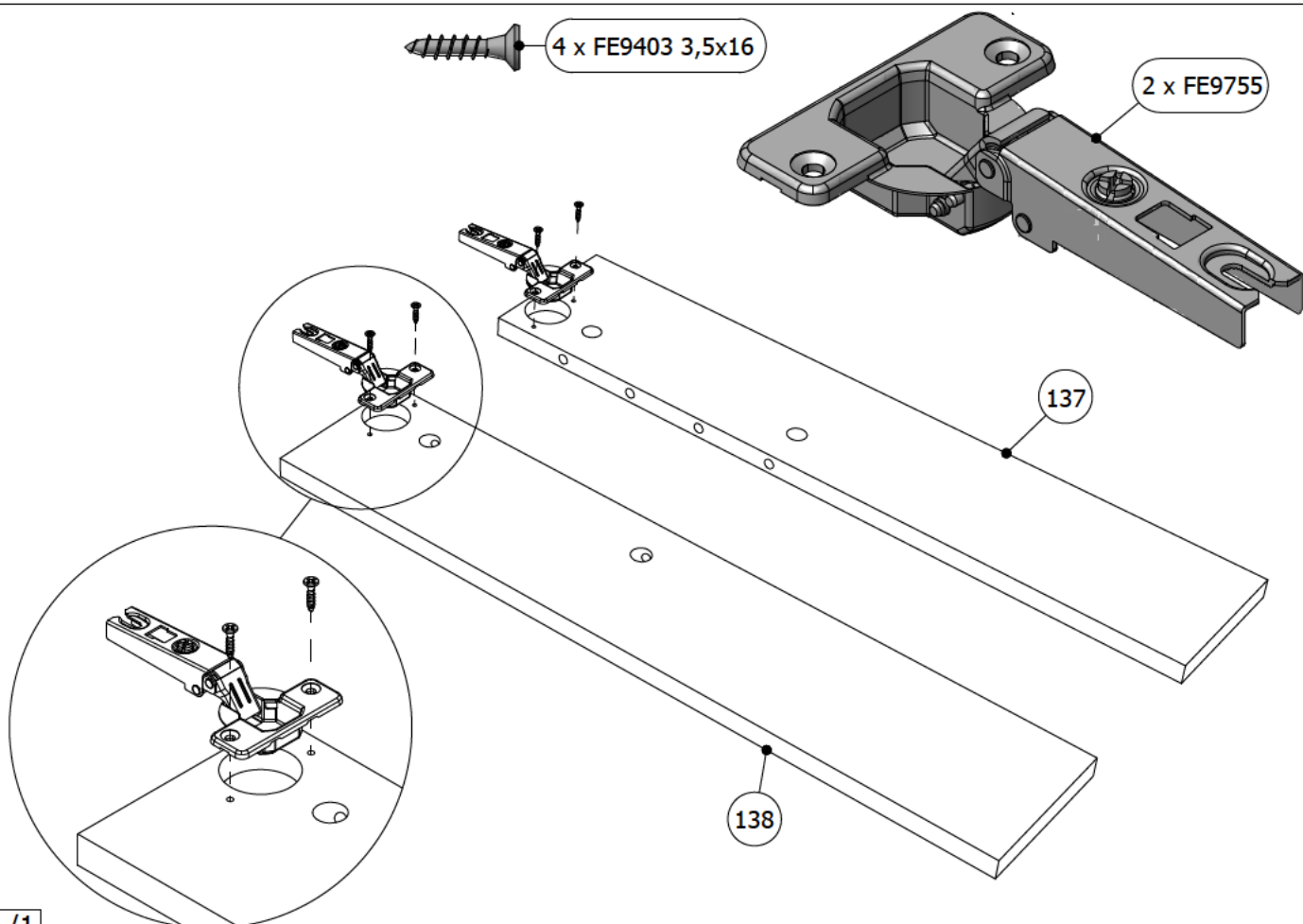

4 x FE2279



4 x SPL001



4 x FE9604



36

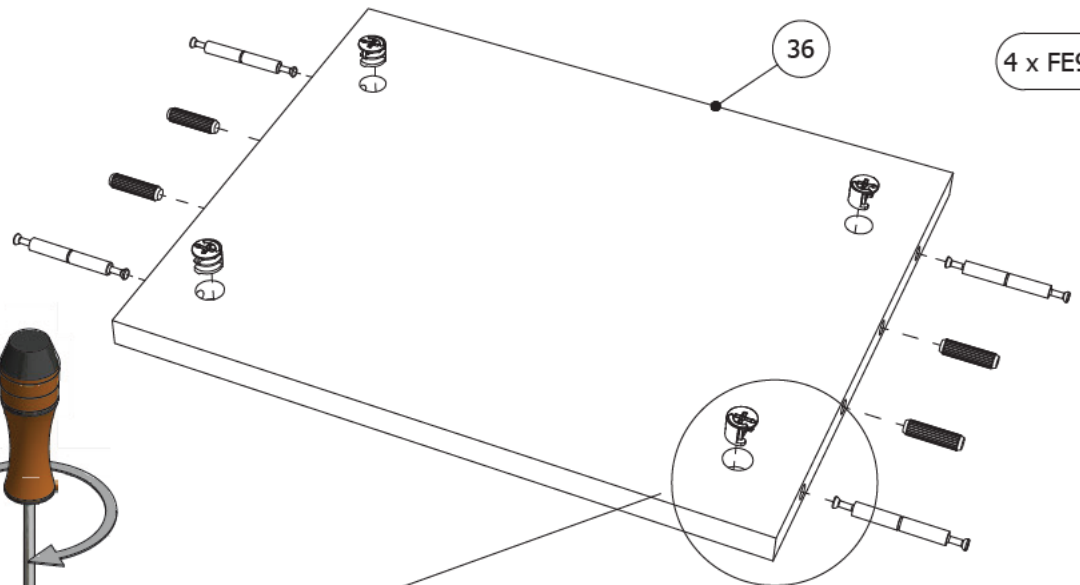

180°

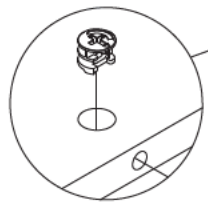
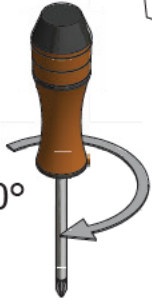

4 x FE9604

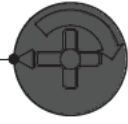

8 x FE2457



137

36

138

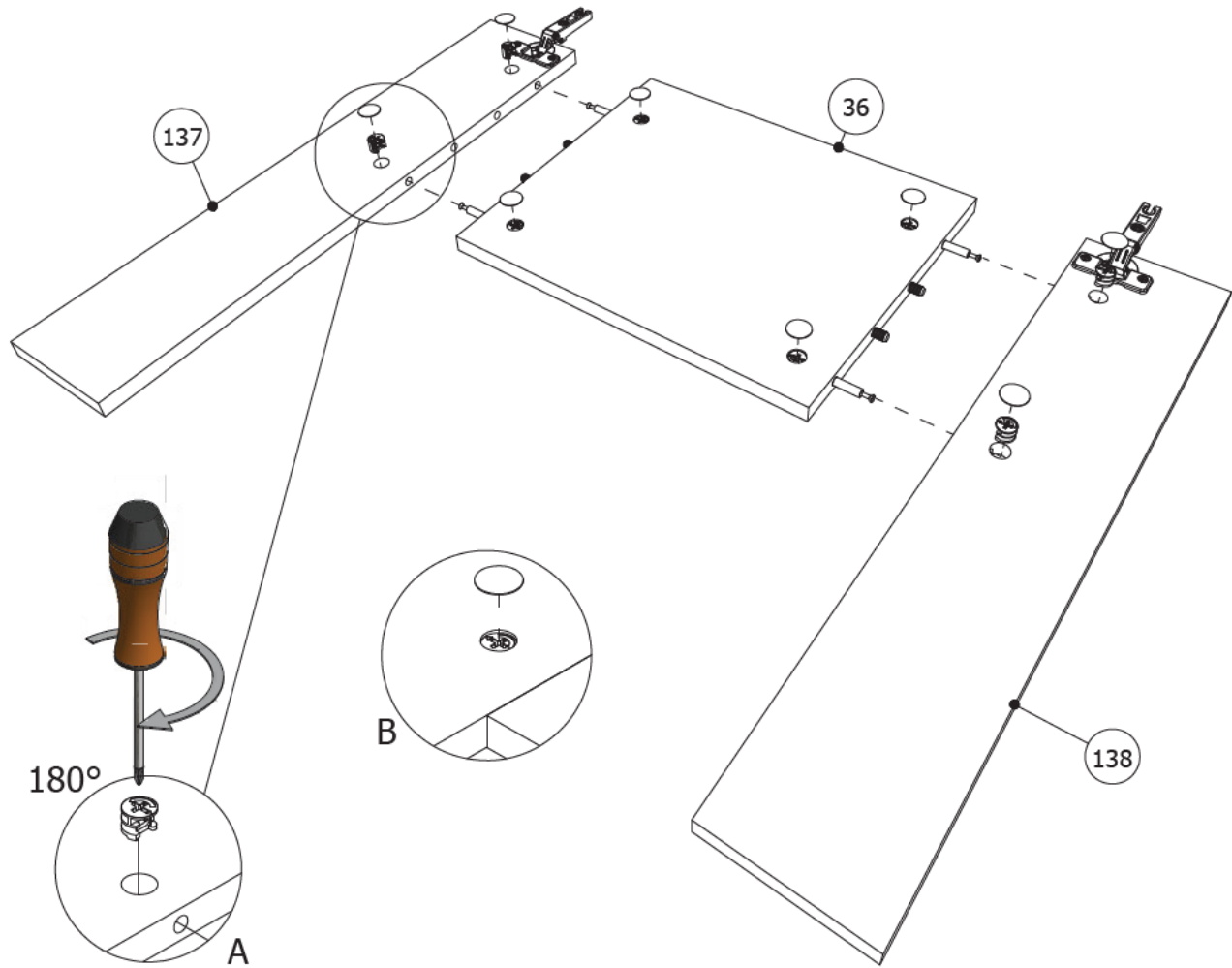

180°

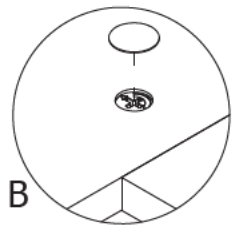
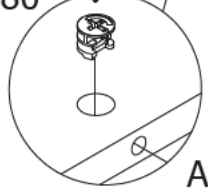
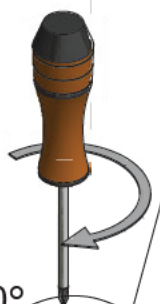

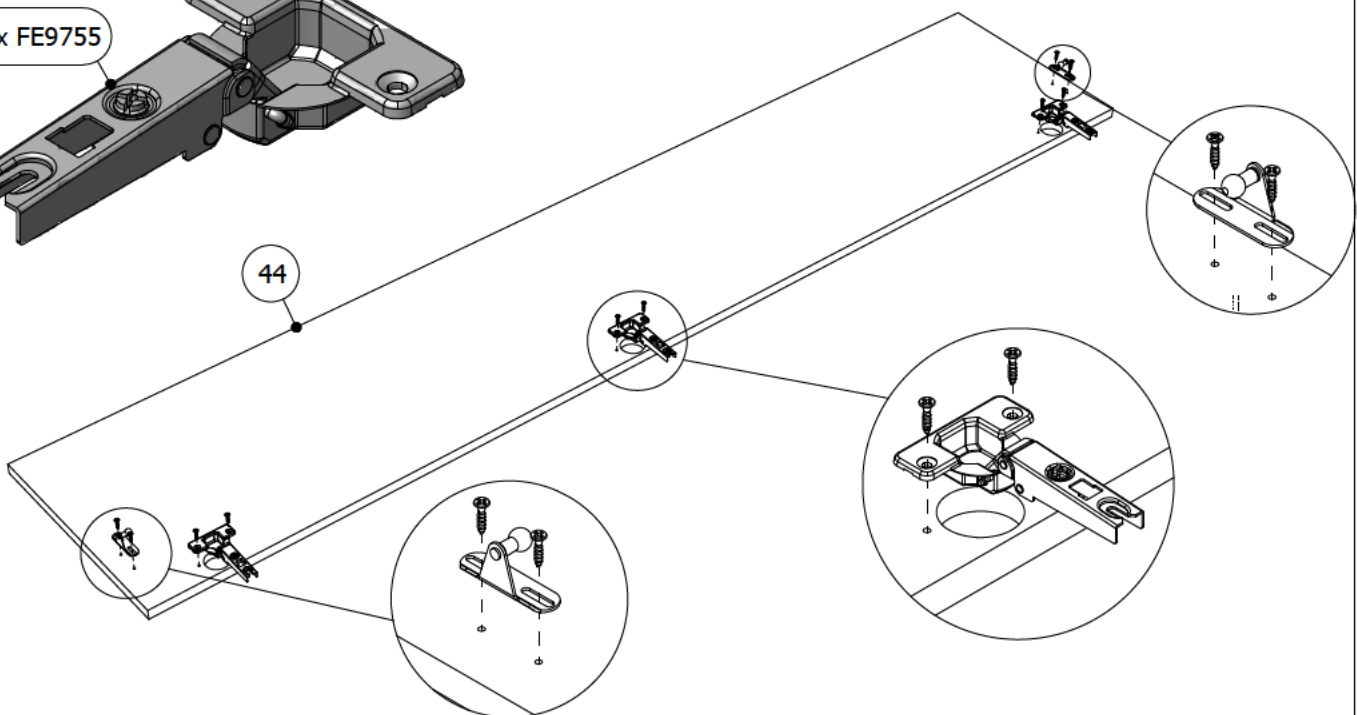
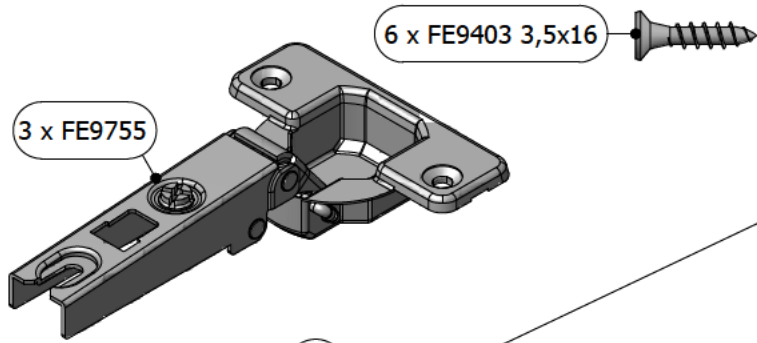
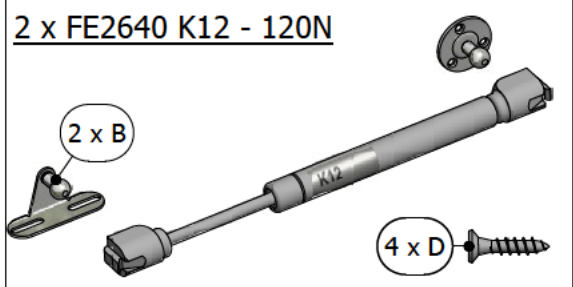
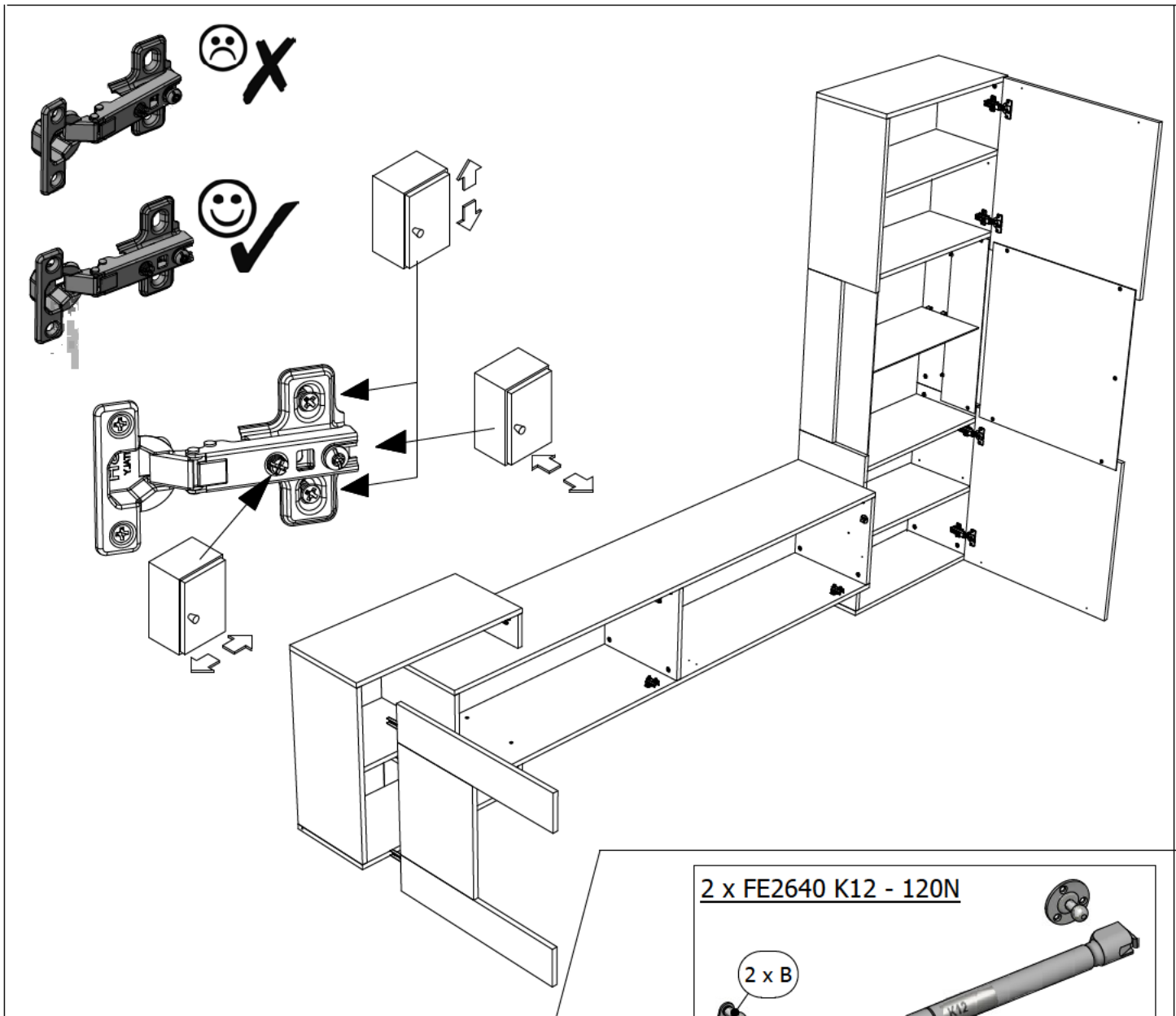

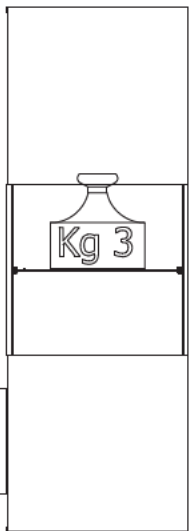
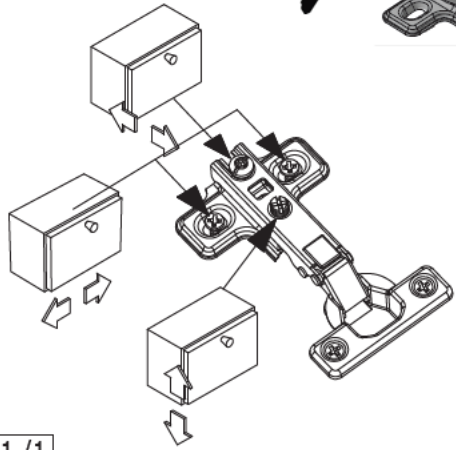
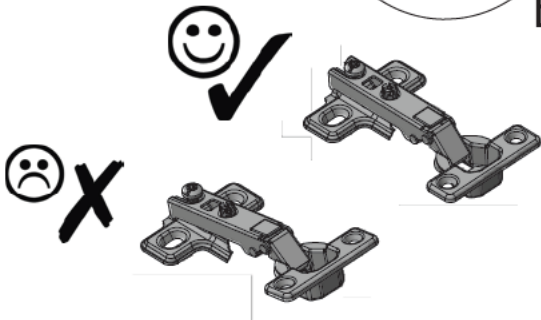
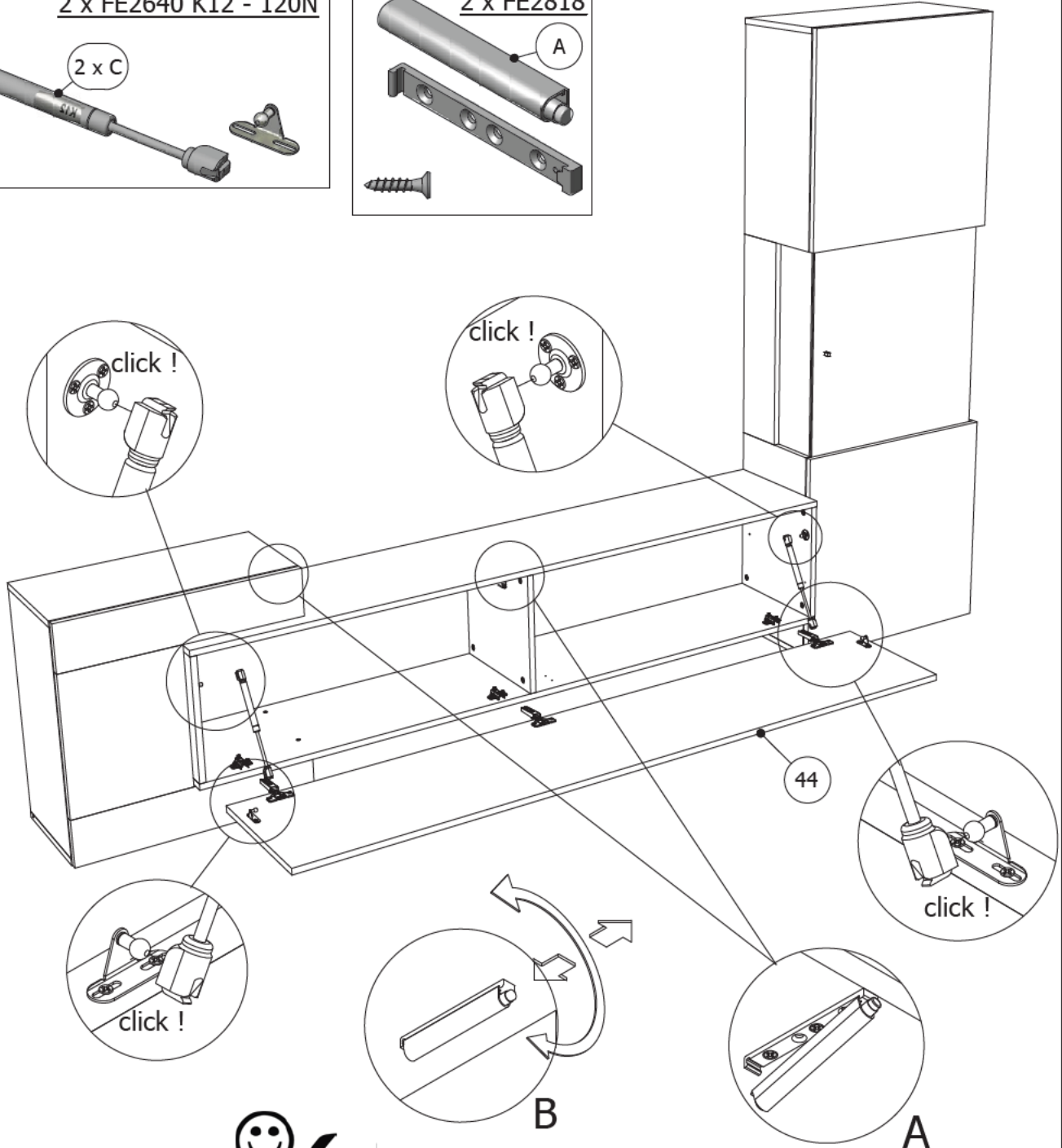
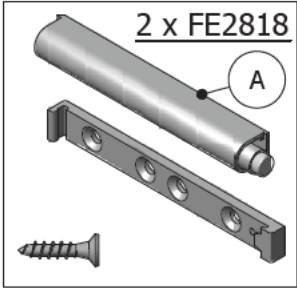
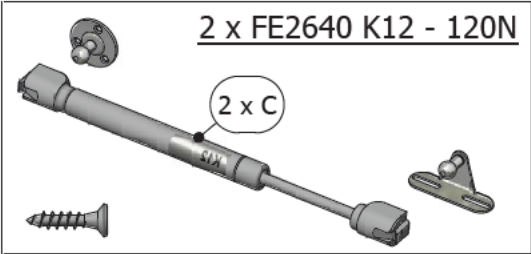

DE Pflegehinweise

Bitte nur mit einem Staubtuch oder leicht feuchtem Lappen reinigen. Keine scheuernden Putzmittel verwenden.
Schützen Sie Ihre Möbel generell vor Wasser (z.B. beim Wischen oder Blumen gießen). Die Feuchtigkeit kann in das Möbelstück eindringen und es beschädigen.

UK USA Care tips

Please only clean with a duster or a damp cloth. Do not use any abrasive cleaners.
In general, keep water away from your furniture (e. g. when mopping or watering plants). The moisture may penetrate the furniture and damage it.

NL Reinigingsnotities

Reinig alleen met een stofdoek of een lichtjes vochtige doek. Gebruik geen schurende poetsmiddelen.
Beschermt uw meubelen doorgaans tegen water (bijv. bij het dweilen of als u de bloemen water geeft). De vochtigheid kan in het meubelstuk dringen en het beschadigen.

PL Wskazówki dotyczące pielęgnacji

Czyszczenie należy wykonać wyłącznie za pomocą ściereczki lub lekko nawilżonego ręcznika. Nie stosować środków czyszczących do szorowania.
Mebel należy chronić przed wodą (np. podczas czyszczenia lub podlewania kwiatków). Wilgoć może wnikać w mebel i uszkodzić go.

RU Обслуживание

Очищайте от пыли тряпкой или слегка влажной ветошью. Не допускается применение чистящих средств, не предназначенных для ухода за мебелью.
Предохраняйте мебель от попадания воды (например, при вытирании или поливке цветов). Не допускайте попадания влаги на мебель, чтобы предотвратить ее повреждение.

RO Indicații de întreținere

Vă rugăm să utilizați la curățare exclusiv o cârpă de șters praful sau o cârpă ușor umezită. Nu utilizați substanțe
Protejați întotdeauna mobilierul contra apei (de exemplu la stergere sau la udarea florilor). Mobilierul poate fi afectat de umiditate și se poate deteriora. Nu utilizați produse abrazive.

ES Alertas de mantenimiento

Limpe sólo con un paño húmedo, no utilice disolventes.
Proteja sus muebles de contacto con el agua. La infiltración de agua podría arruinar los muebles.

AR نصائح الرعاية

يرجى التنظيف فقط باستخدام منفضة أو قطعة قماش رطبة
لا تستخدم أي منظفات خشنة أو كاشطة يمكن أن تخدش الأثاث
بشكل عام، أبق الماء بعيدا عن الأثاث خاصة عند مسح الأرض أو
سقي النباتات الرطوبة قد تخترق الأثاث و تتلفه

TR Bakım

Lütfen sadece bir toz beziyle veya hafif nemli yumuşak bir bezle siliniz. Aşındırıcı temizlik malzemeleri kullanmayınız.
Genelde mobilyalarınızı sudan koruyunuz (örneğin, yerleri paspaslarken veya çiçekleri sularken). Nem, mobilya parçasına nüfuz edebilir ve zarar verebilir.

IT Avvisi di manutenzione

Pulire solamente con un panno umido, non utilizzare solventi.
Proteggere i mobili dal contatto con acqua. L'infiltrazione dell'acqua potrebbe rovinare il mobile.

FR Conseil d'entretien

Nettoyer avec un plumeau ou un chiffon humide. Ne pas utiliser de dissolvants.
En général, garder l'eau loin de vos meubles (par exemple lors de lavages, ou bien pour l'arrosage des plantes). L'humidité peut pénétrer les meubles et les endommager.

CZ Ošetřování

Čistěte prosím jen prachovkou nebo lehce navlhčeným hadrem. Nepoužívejte drhnoucí čisticí prostředky.
Chraňte váš nábytek před vodou (např. při utírání prachu nebo zalévání květin). Vlhkost může do nábytku proniknout a poškodit ho.

SK Ošetrovanie

Na čistenie používajte len prachovku alebo zľahka navlhčenú utierku. Nepoužívajte žiadne drhúce čistiace prostriedky.
Chráňte váš nábytok celkovo pred vodou (napr. pri utieraní alebo polievaní kvetín). Vlhkosť môže vniknúť do nábytku a poškodiť ho.

HU Ápolási tanácsok

Kérjük, csak portörölő kendővel vagy enyhén nedves ronggyal tisztítsa. Ne használjon dörzsölhető tisztítószert.
Védje a bútort a víz ellen (pl. a letörölések során, ill. a növények öntözésekor). A nedvesség behatolhat a bútortáborba és azt tönkre teheti.

PT Alertas de manutenção

Limpe apenas com um pano úmido, não use solventes.
Proteja sua mobília de contacto com a água. A infiltração de água pode arruinar o mobiliário.

