

# ASSEMBLY INSTRUCTIONS

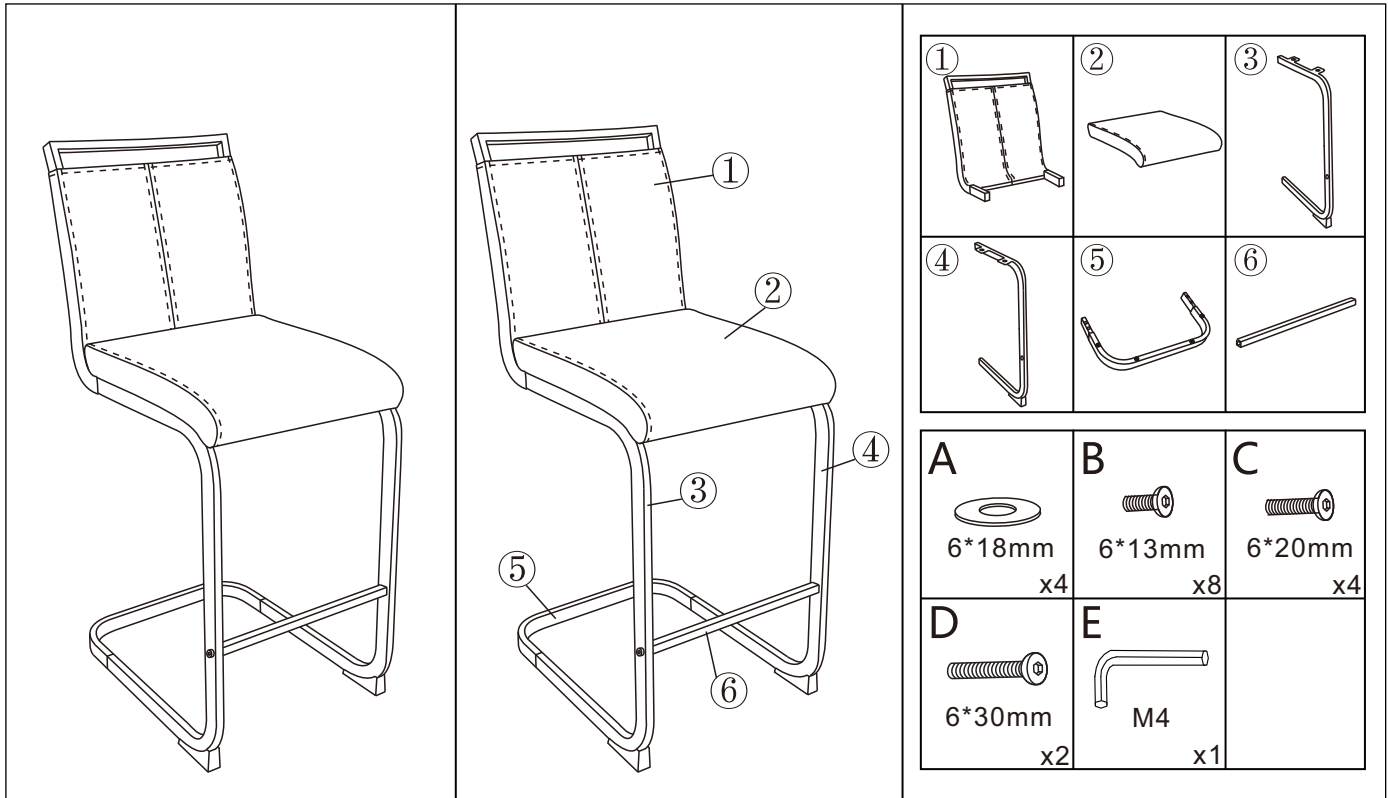

**STEP 1** ③ and ④ are connected to ⑤ respectively, ⑥ is connected to ③ and ④, B and D are inserted into the corresponding hole and fastened with E.

