

ASSEMBLY INSTRUCTION

Coffee Table

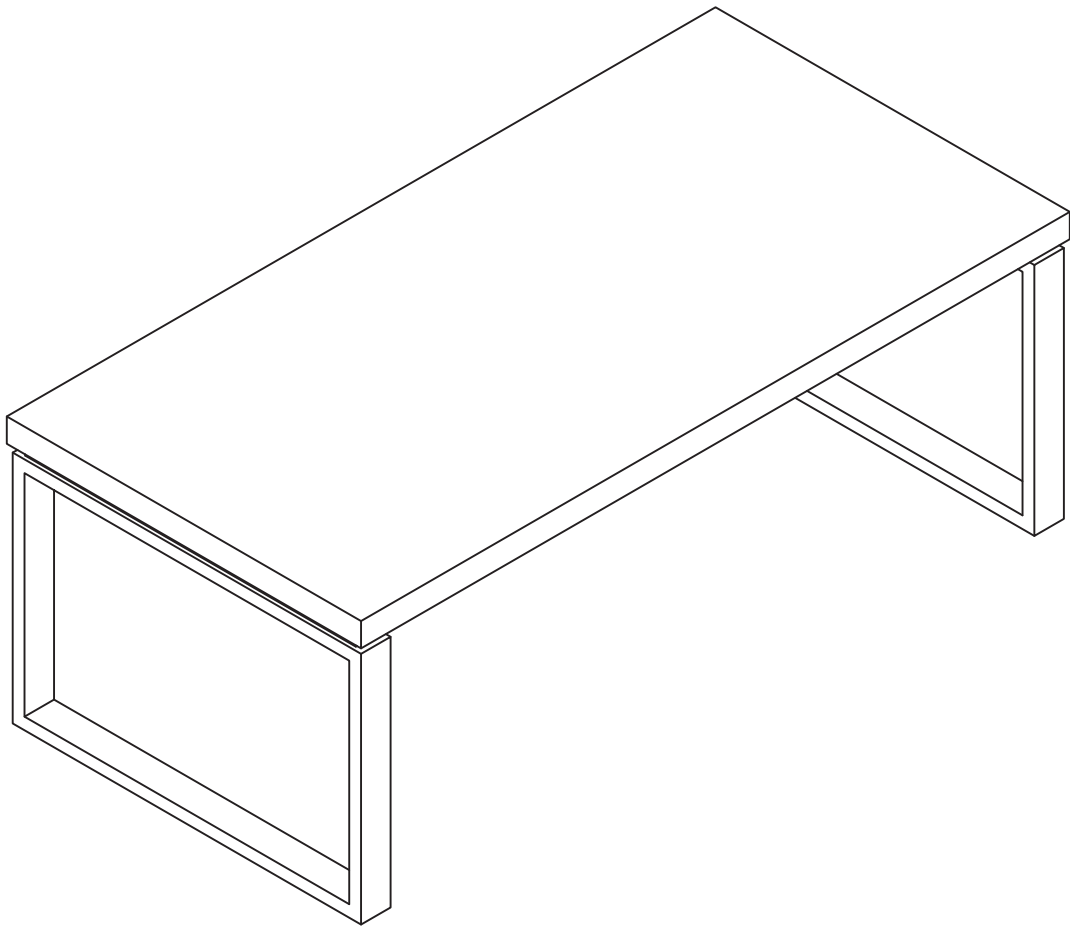

Part Identification

While not all parts are labeled, some of the parts will have a label to help distinguish similar parts from each other. Use this part identification to help identify similar parts.

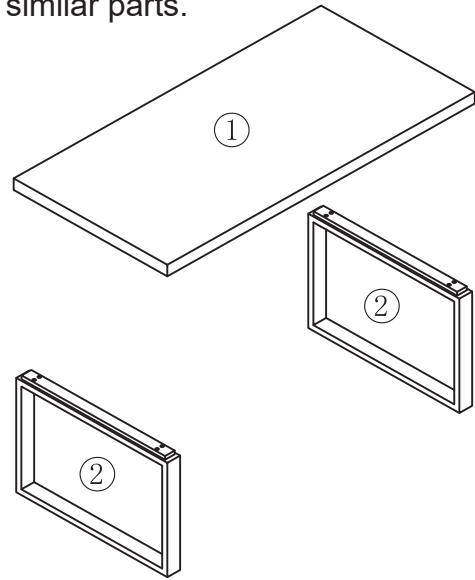
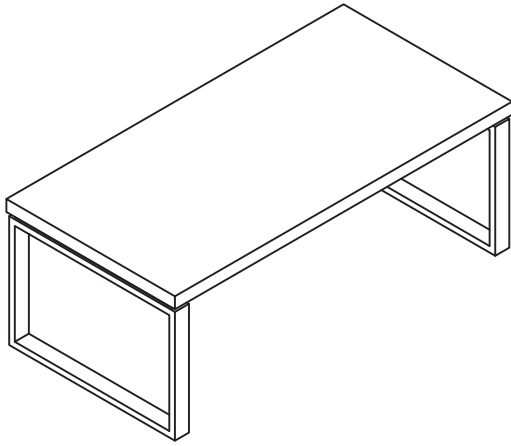

1

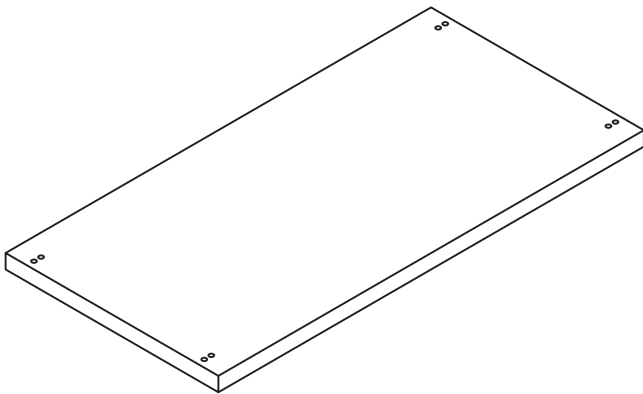
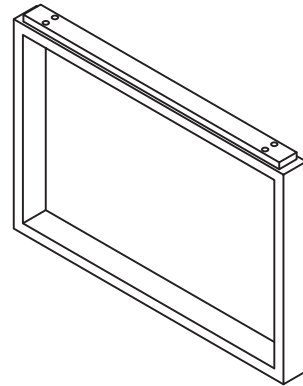

Table Top 1 pc

2



Metal Frame 2 pcs

A

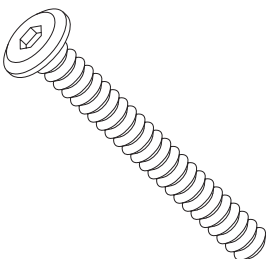

**Bolt
M6*50mm 8 pcs**

B

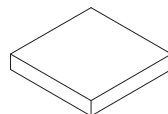

**Anti-skid Pad
45*45*5mm 4 pcs**

C

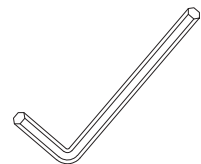

**Allen Key
4mm 1pc**

Step 01

NOTE: DO NOT fully tighten all bolts until all parts are in place.

🔌 Lay the Table Top(①) upside down onto a clean smooth surface such as carpet or cardboard. Align and fix two Metal Frames(②) to the Table Top(①) with eight bolts(A) by Allen Key(C). Do not fully tighten all bolts until all parts are in place.

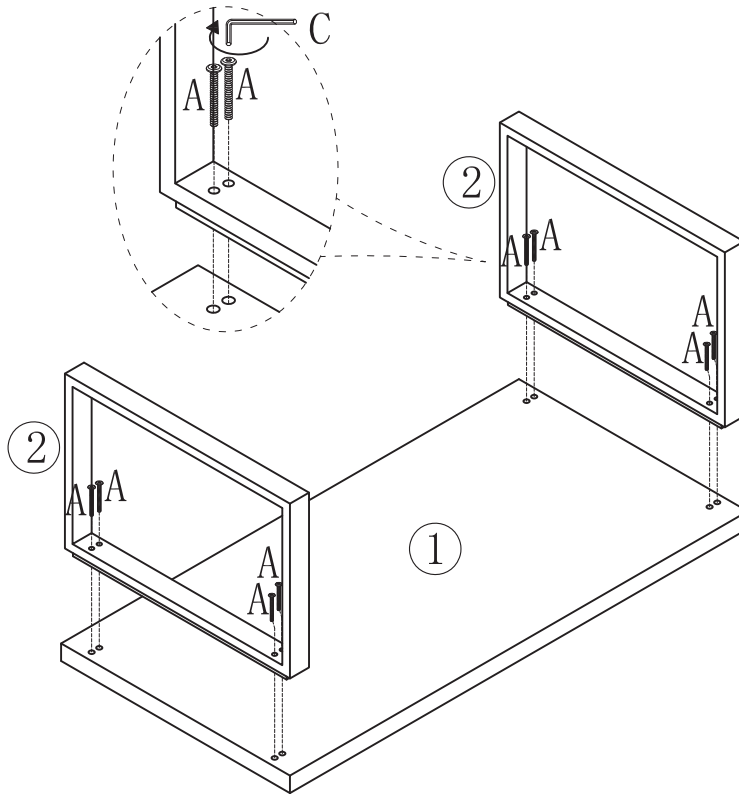

Step 02

NOTE: If holes don't align, loosen all bolts and adjust the holes slightly. After all holes are aligned, fully tighten all bolts.

- 🔌 2.1 Stick four anti-skid pads(B) onto the bottom of table legs.
- 2.2 With the help of another person, turn the table upright and complete the assembly.

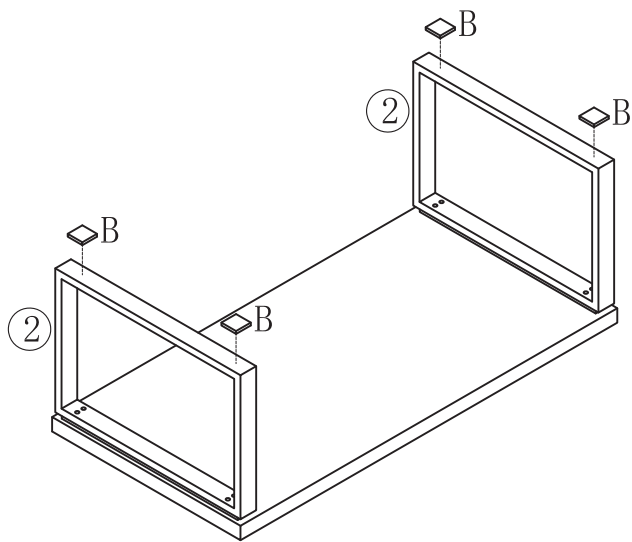

2.1

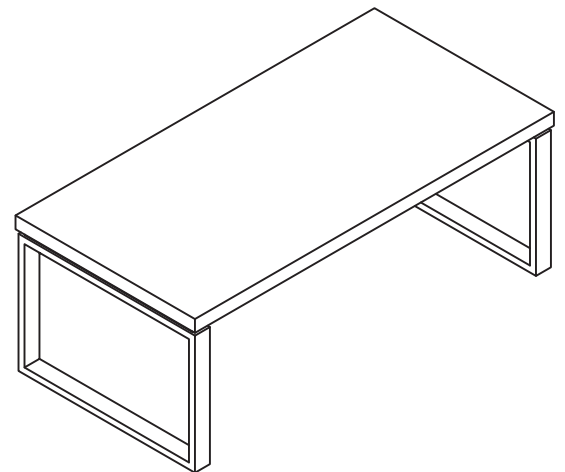

2.2

ASSEMBLY TIPS

1. Please read the assembly instructions first and become familiar with the parts.
2. Proper assembly of this item requires 2 people.

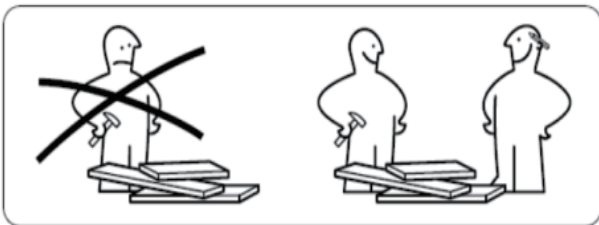

3. Unpack and assemble this unit in an spacious area, assemble the unit on top of the empty carton or carpet to prevent scratches.

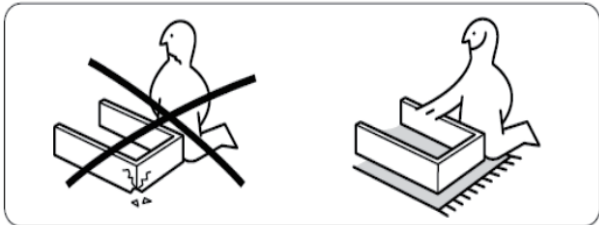

4. To avoid accidentally discarding small parts or hardware, DO NOT dispose of any contents until assembly is completed.
5. **Do not fully tighten all bolts until all parts are in place.** Failure to follow these instructions may cause the bolts to misalign during assembly.

CARE INSTRUCTIONS

- (1) Hardware may loosen overtime. Periodically check that all connections are tight.
- (2) Wipe with a soft, dry cloth. To protect finish, avoid the use of chemicals and household cleaners.
- (3) All hot serving dishes should be placed on a pad.
- (4) Any liquid spilled onto the furniture should be cleaned up immediately with a dry cloth.