

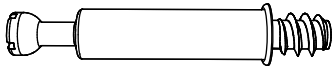









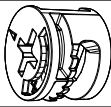





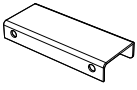

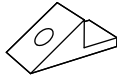





# HARDWARE LIST

NO.	DESCRIPTION	QTY	NO.	DESCRIPTION	QTY
A	 $\Phi 6*35$	31	N	 CL	1
B	 $\Phi 15*10$	31		 DL	
C	 $\Phi 6*30$	12		 CR	
D	 $\Phi 4*35$	12		 DR	
E		4	O	 $\Phi 3.5*12$	32
F	 $\Phi 4*12$	8	P		8
G		4	Q	 $\Phi 3*16$	8
H	 $\Phi 4*12$	20	R		4
I		4	S	   	1
J		4	T		2
K		4	U	 $\Phi 4*14$	12
L	 $\Phi 4*12$	4			
M		2			

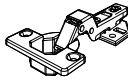
## Layout Parts on Soft Surface

Lay out all parts on a soft surface i.e. Rug, Carpet or Packaging Carton

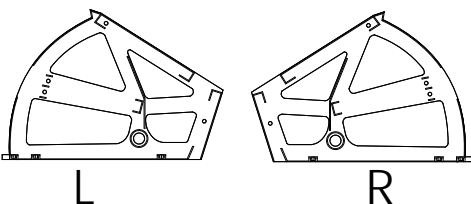
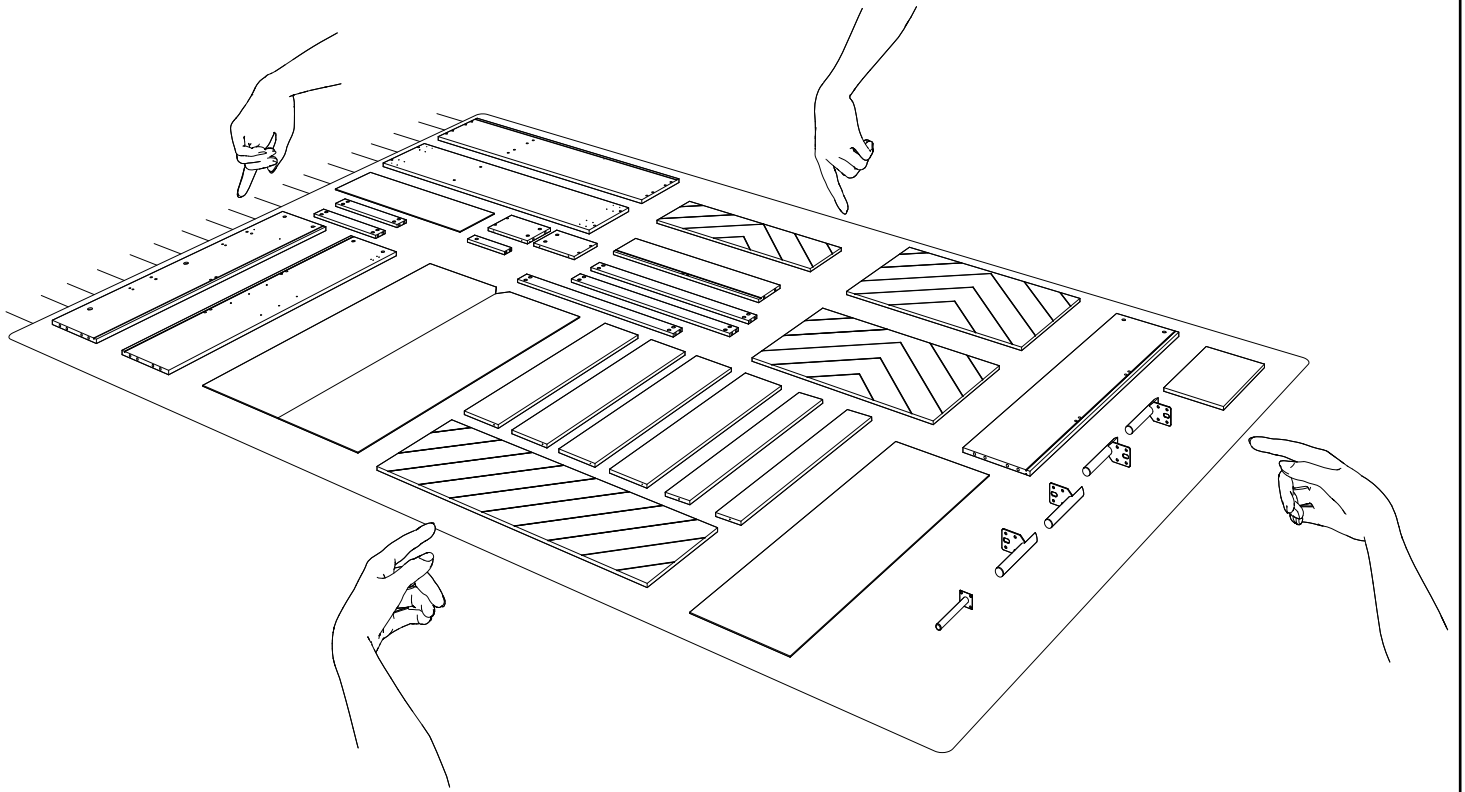

## Assembly Details

60 mins

Approximate Assembly Time

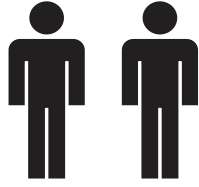

2 person assembly

Floor Area:

1.5X1.5 meters

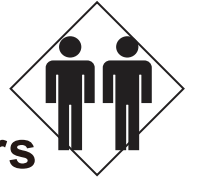

Required Assembly Space

Required Assembly Tools Phillips-Head Screwdriver

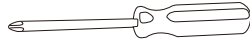









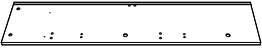
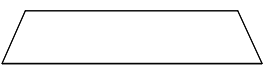
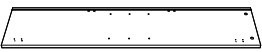
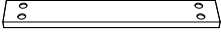
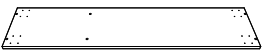
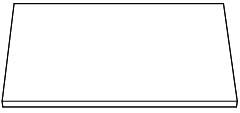
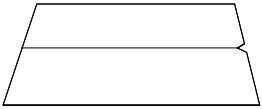
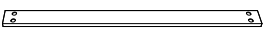

## Tips Before you Start

1. Please check that all parts are present before you start the assembly of your furniture.
2. For ease and speed of assembly, we recommend that before you commence each step of the assembly, that you identify all the parts required for that step.
3. We recommend that, where possible, all items are assembled near to the area in which they will be placed in use, to avoid moving the product unnecessarily once assembled.
4. For the protection of your furniture, we recommend that the product is placed on a protected surface during assembly to prevent any damage.
5. During assembly please take care not to over-tighten any fittings, as this may damage the product. Do not use power tools.
6. Always place the product on a flat, steady and stable surface.
7. Do not stand on the product. Do not use the product as a stepladder.
8. Please use caution and care when lifting the product to avoid personal injury and/or product damage.

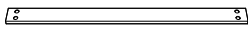
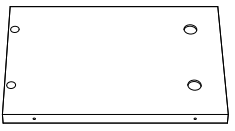
## Care and Maintenance

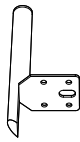
- Upon completion of assembly be sure that all screws, bolts and fastening
- Never clean with abrasive ammonia base, bleach base or spirit type cleaners.
- Use only replacement parts supplied by manufacturer.

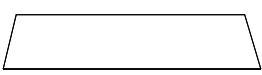
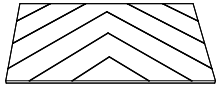
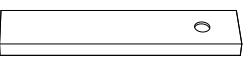
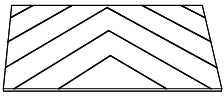
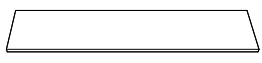
# PART LIST

LTEM.	DESCRIPTION	PART	QTY	LTEM.	DESCRIPTION	PART	QTY
1	TOP PANEL		1	13	SHELF PANEL		2
2	LEFT SIDE PANEL		1	14	BACK PANEL		1
3	RIGHT SIDE PANEL		1	15	MIDDLE SUPPORT PANEL		2
4	BOTTOM PANEL		1	16	SHELF PANEL		1
5	BACK PANEL		1	17	CROSSING BAR		2
6	DRAWER FRONT PANEL		1	18	MIDDLE SUPPORT PANEL		1
7	DRAWER LEFT SIDE PANEL		1	19	MIDDLE PANEL		1
8	DRAWER RIGHT SIDE PANEL		1	20	METAL LEG		4
9	DRAWER BACK PANEL		1	21	DOOR PANEL		1
10	DRAWER BOTTOM PANEL		1	22	FRONT PANEL		1
11	DRAWER SUPPORT PANEL		1	23	FRONT PANEL		1
12	SHELF PANEL		4	24	METAL LEG		1

# INSTALLATIONS

STEP 1

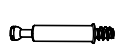

AX6

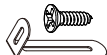

SX1

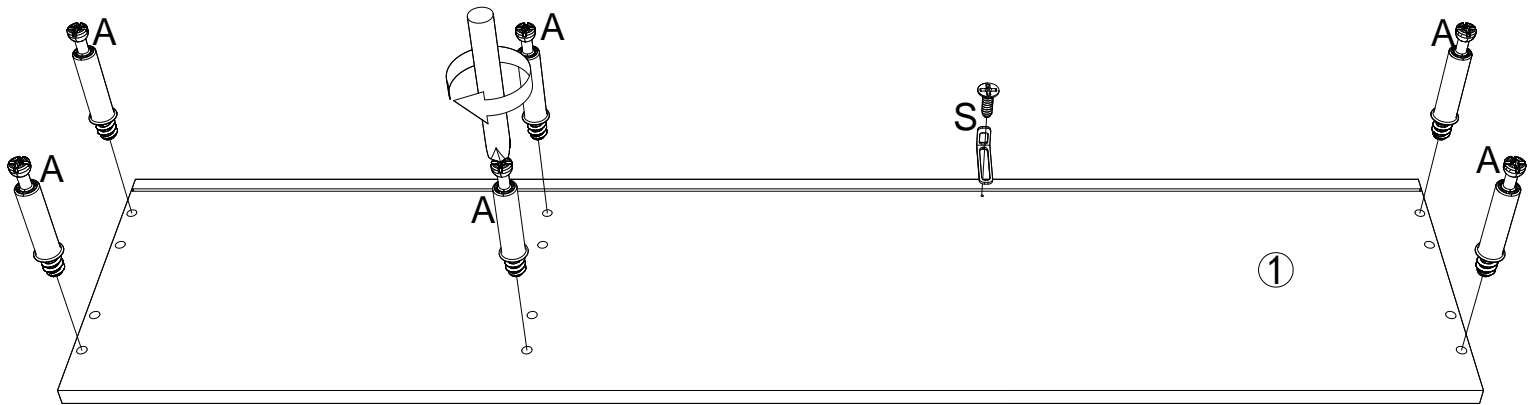

STEP 2



NX1



OX2

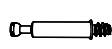

AX6



IX2



JX2

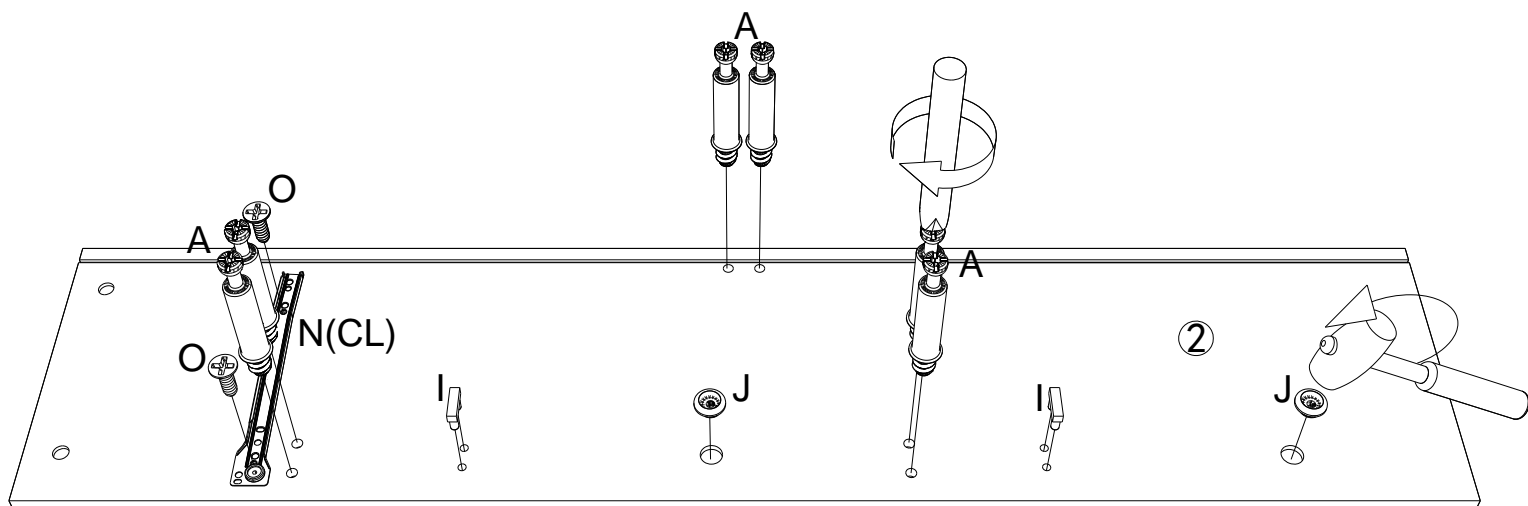
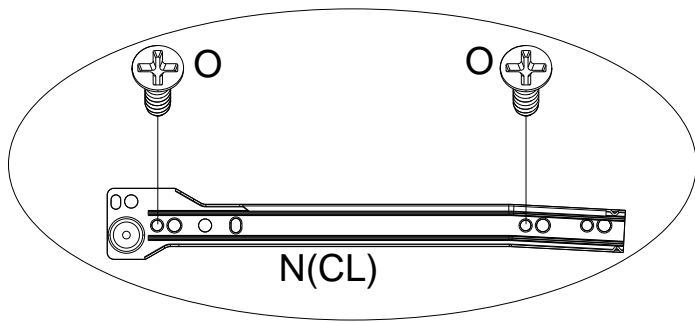

STEP 3

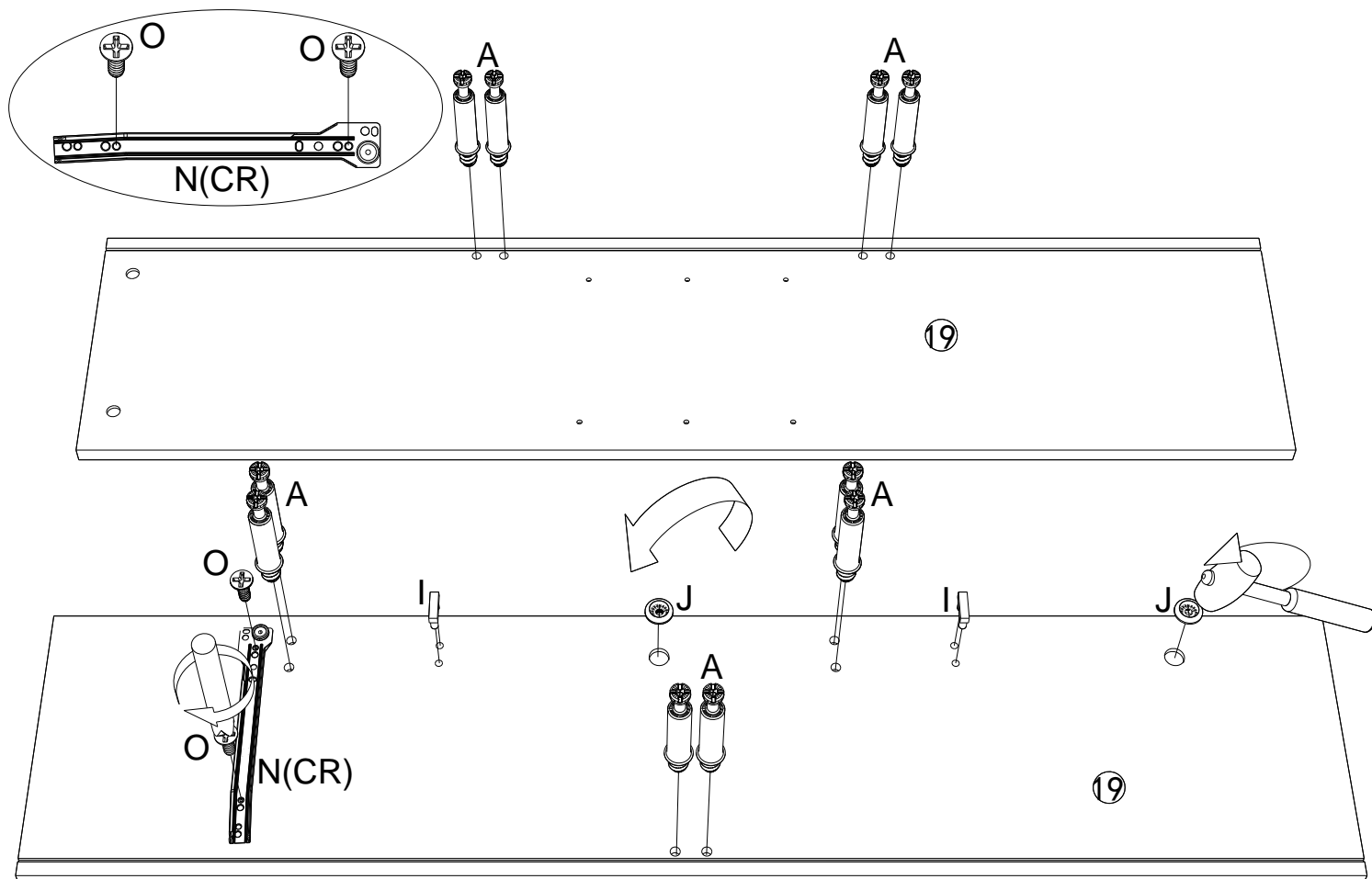

STEP 4

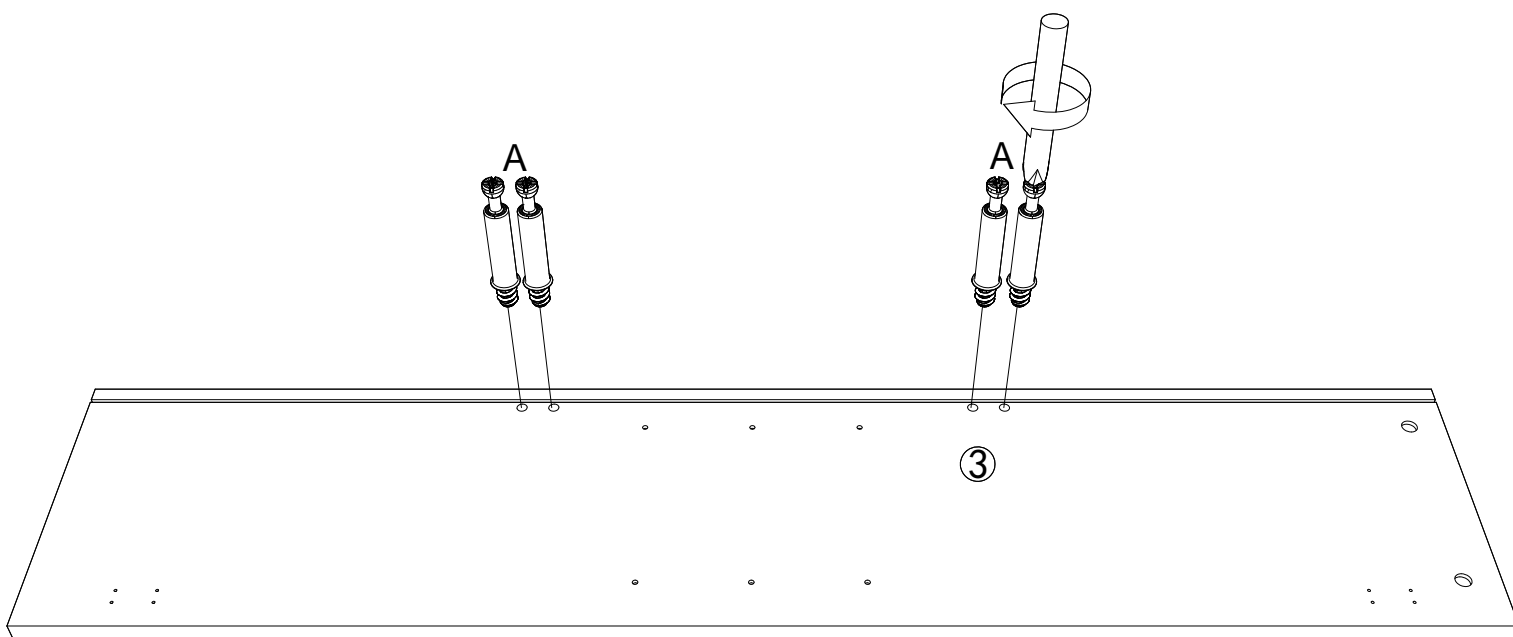

STEP 5



BX8

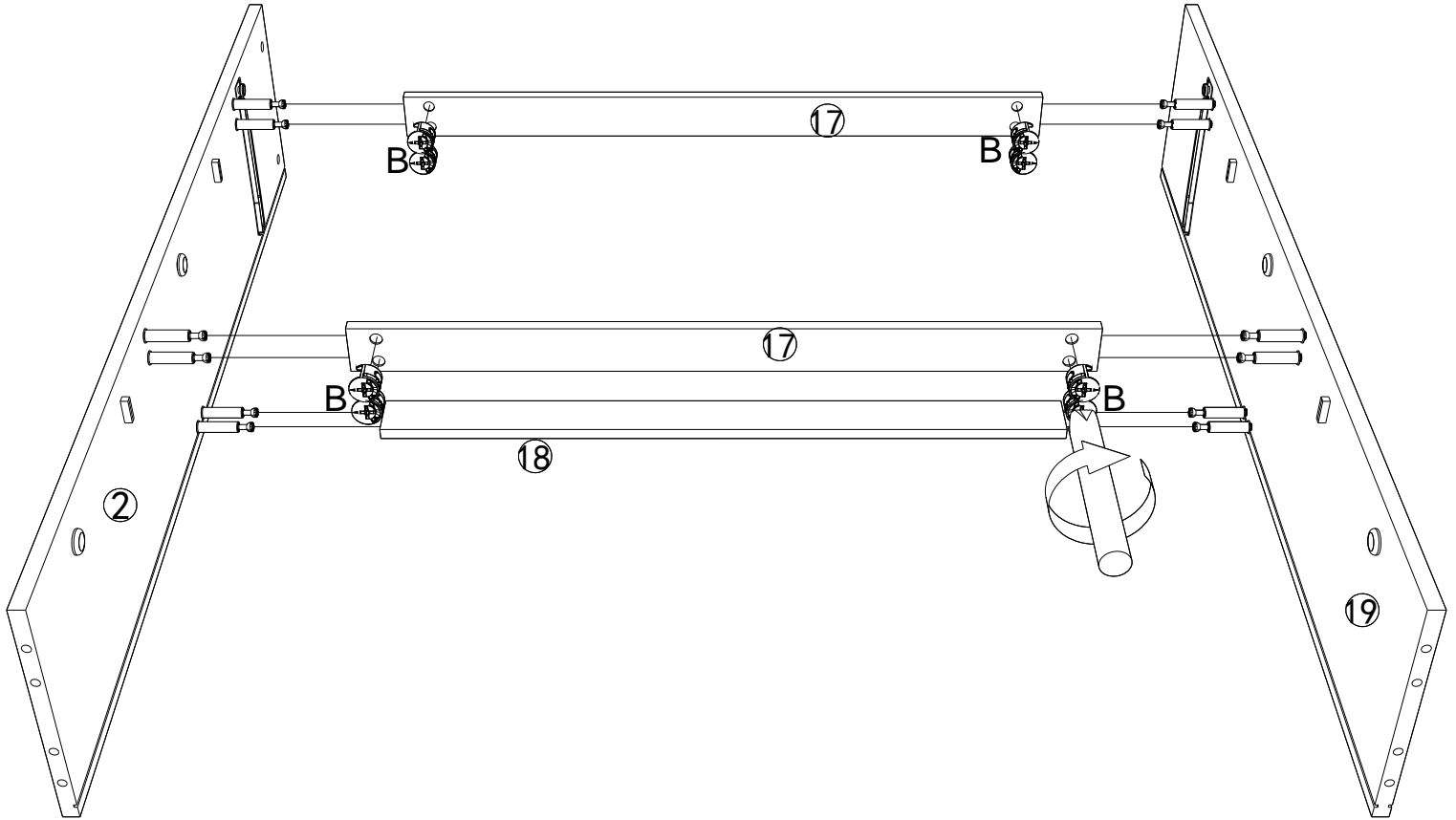

STEP 6

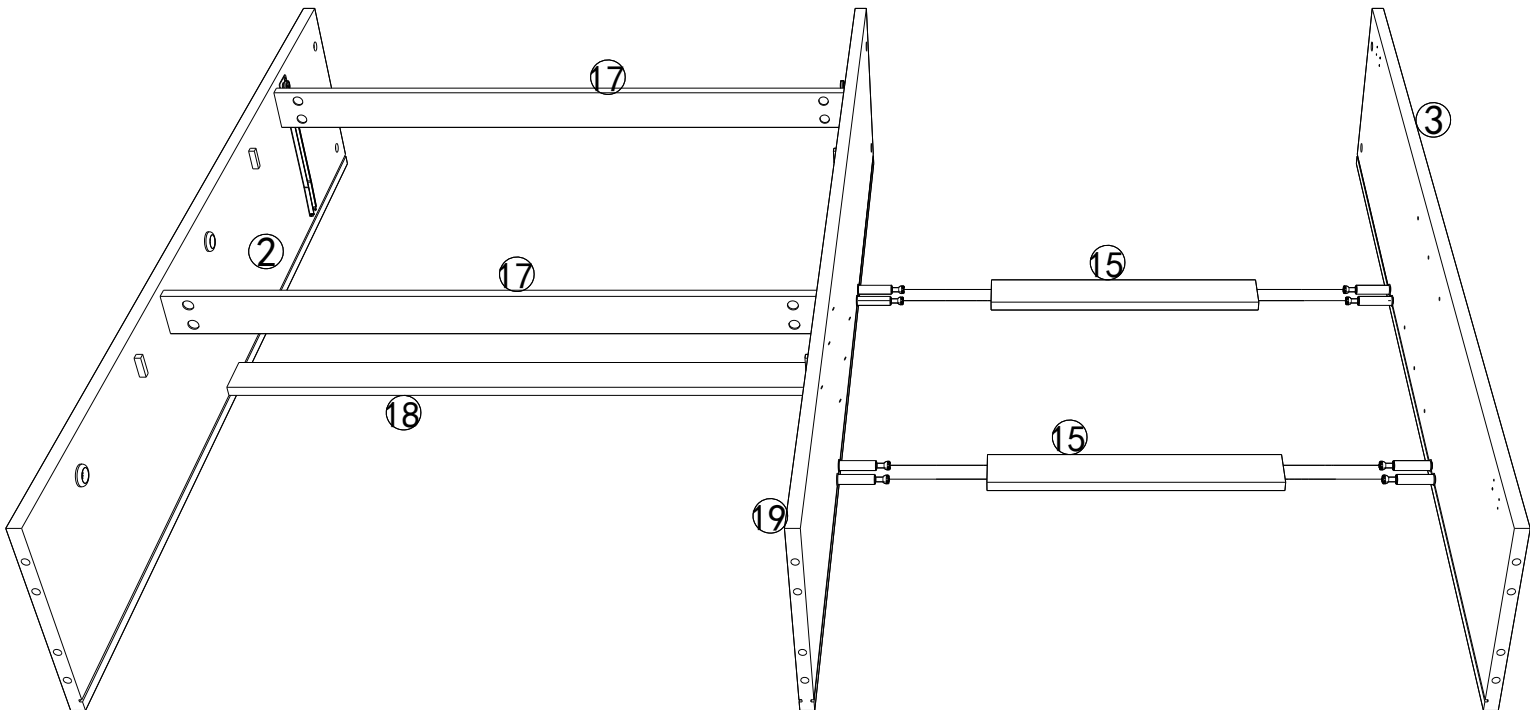

# STEP 7

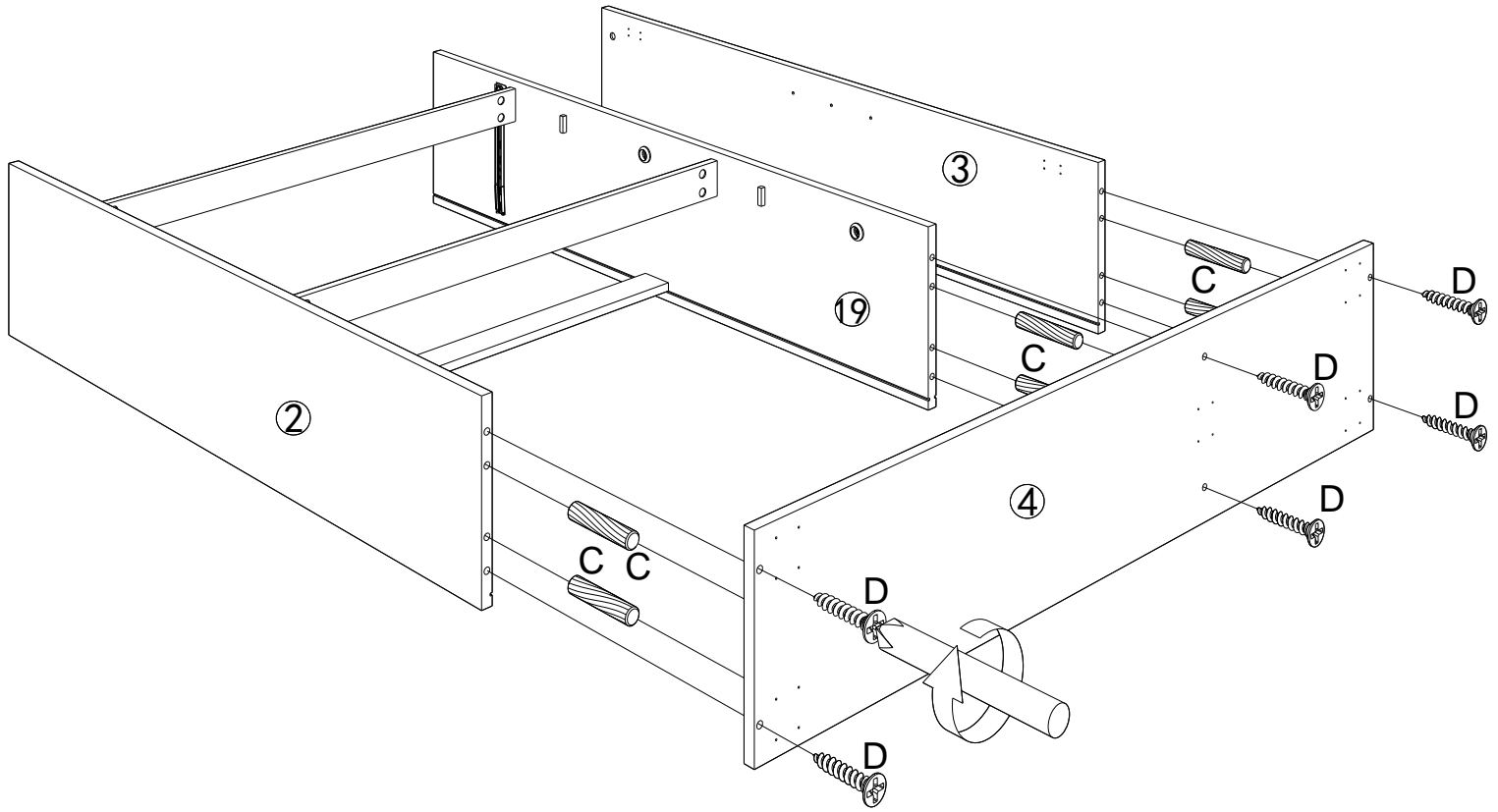

# STEP 8

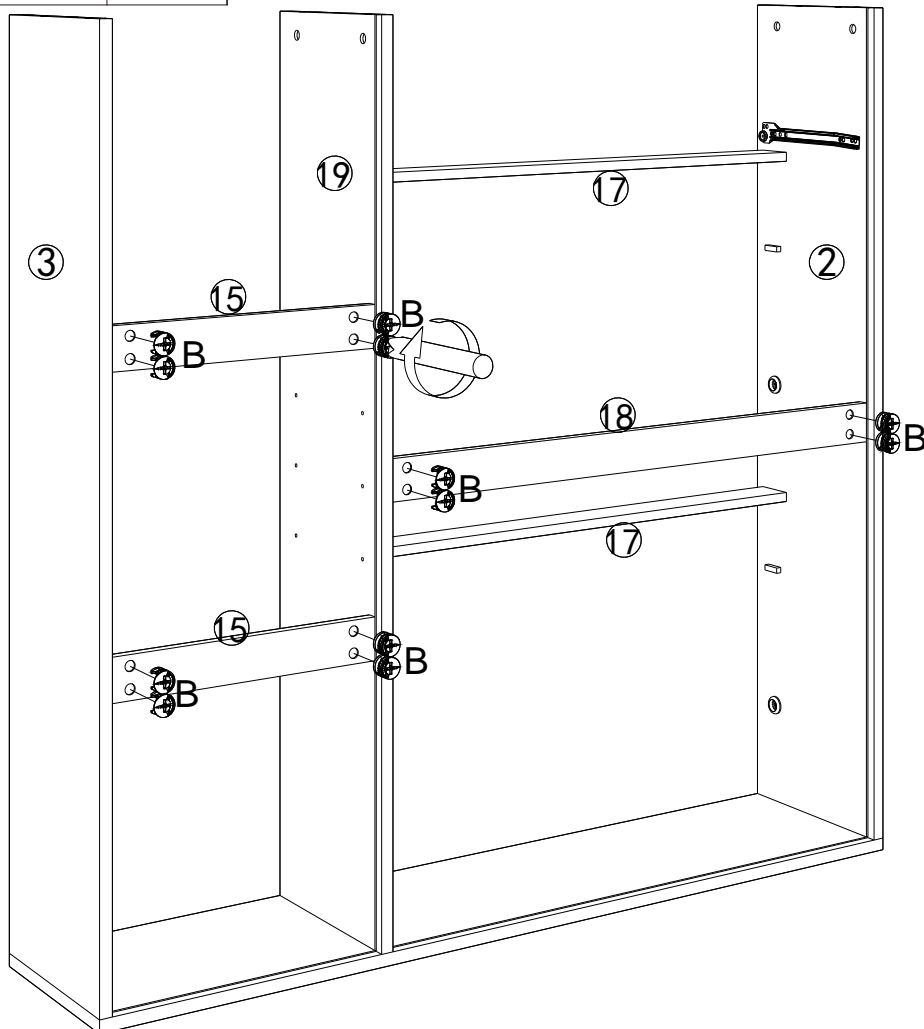

STEP 9

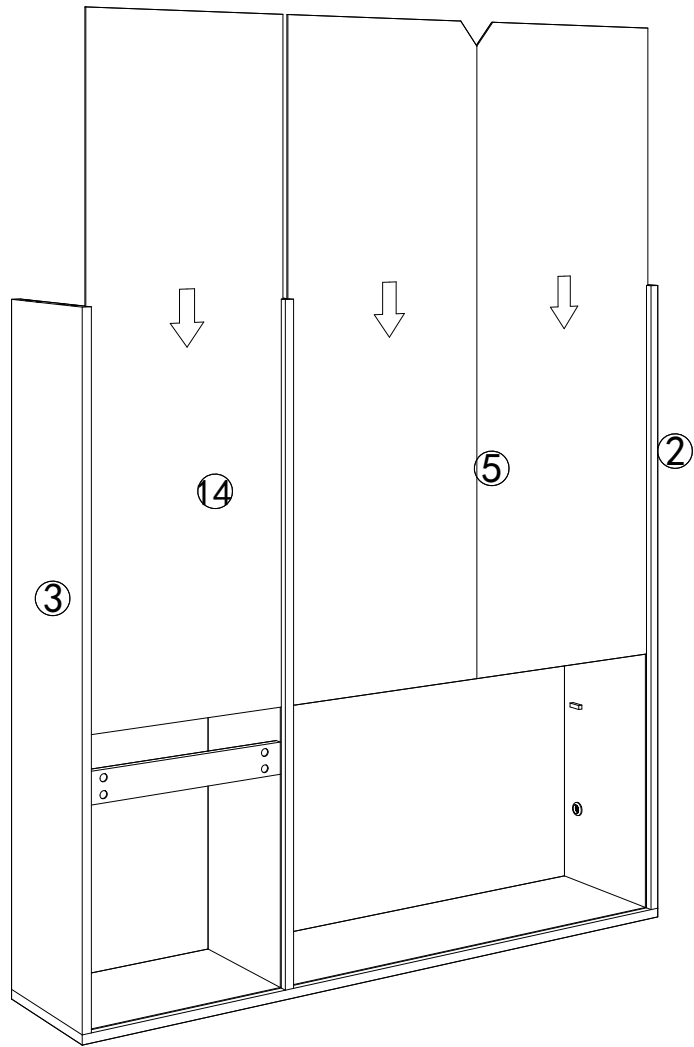

STEP 10



BX6



CX6

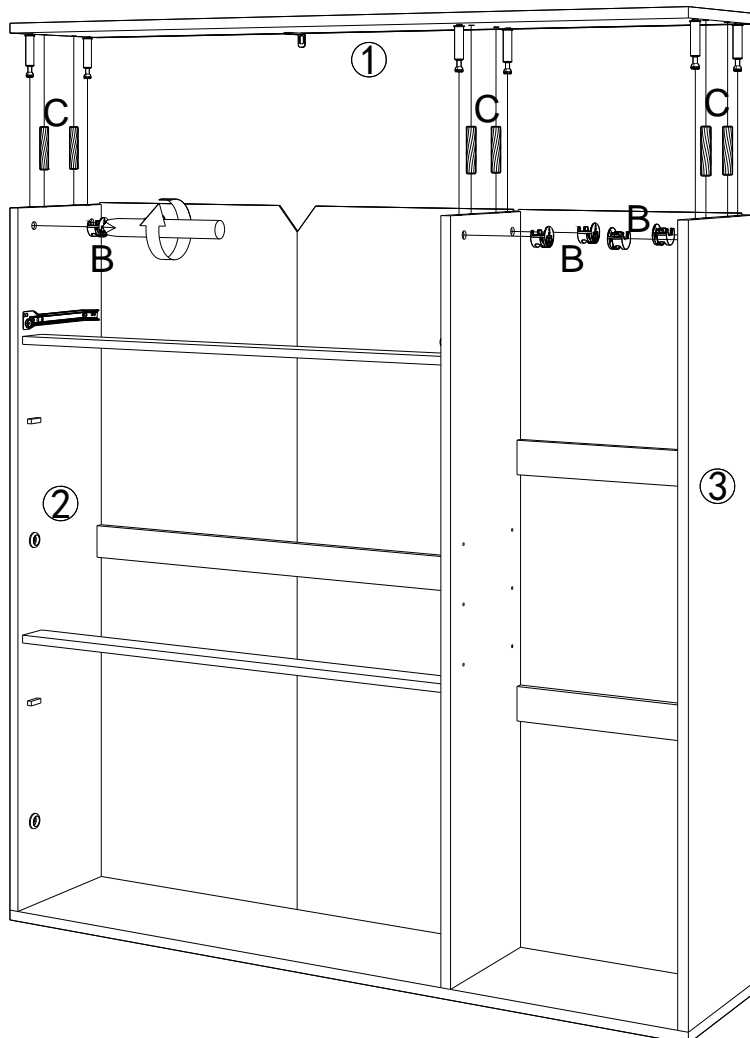

STEP 11



HX20

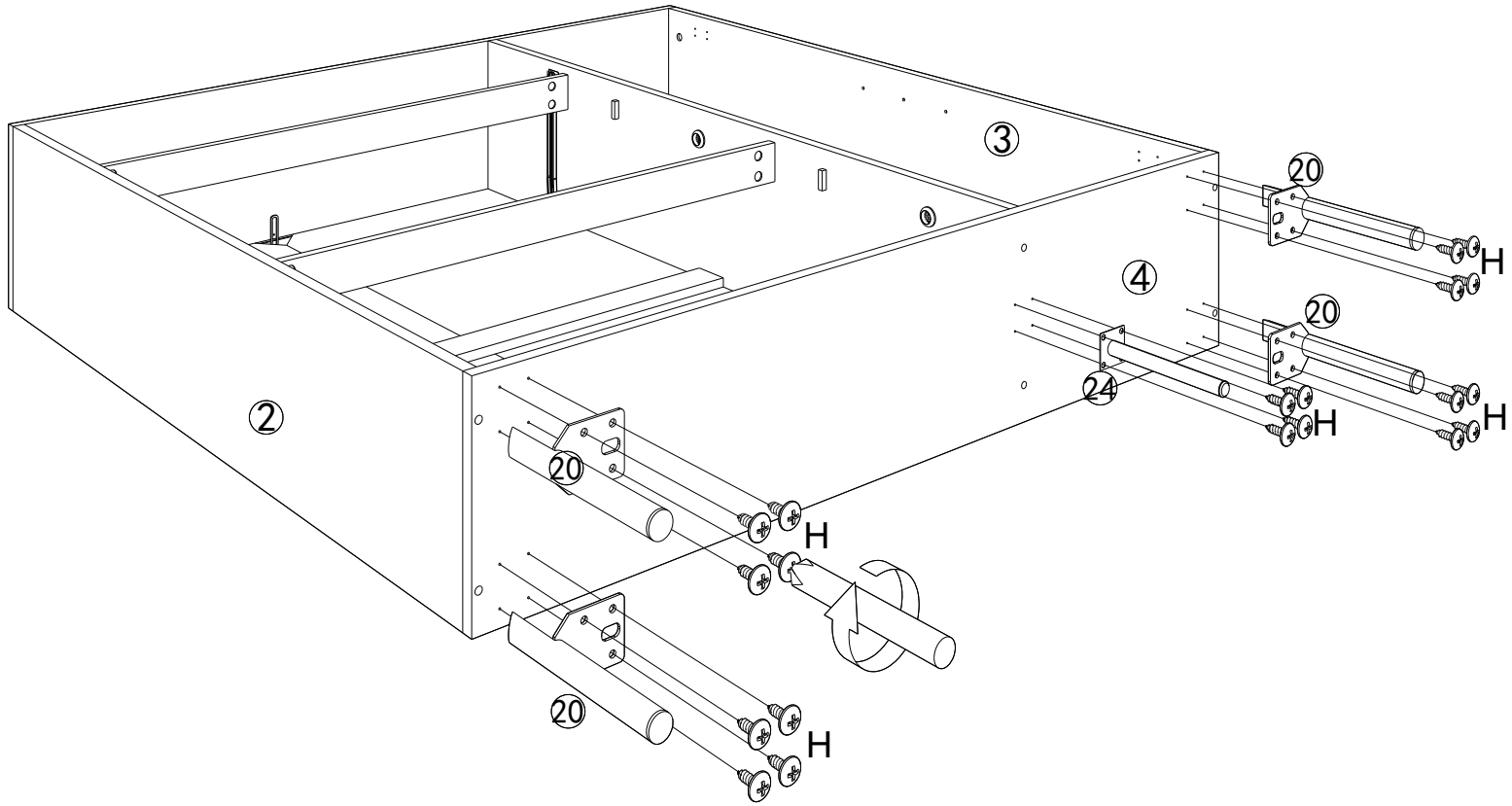

STEP 12

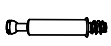

AX5



EX1



FX2

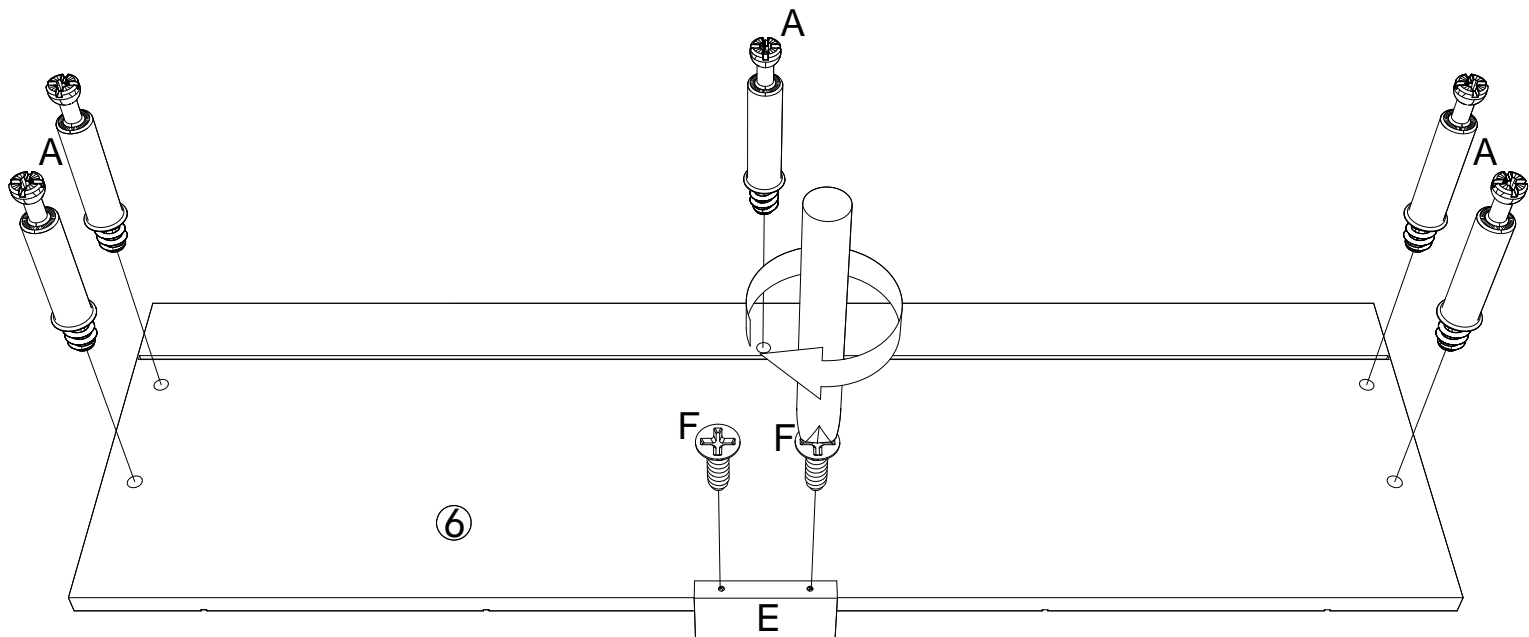

STEP 13



DX6

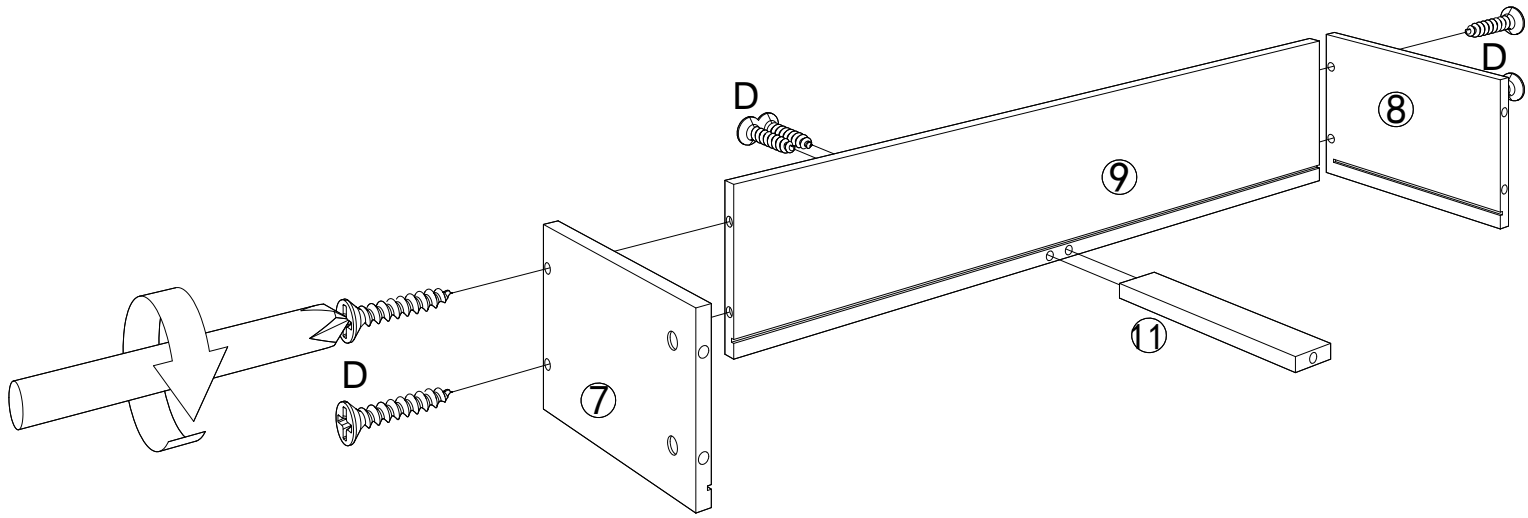

STEP 14

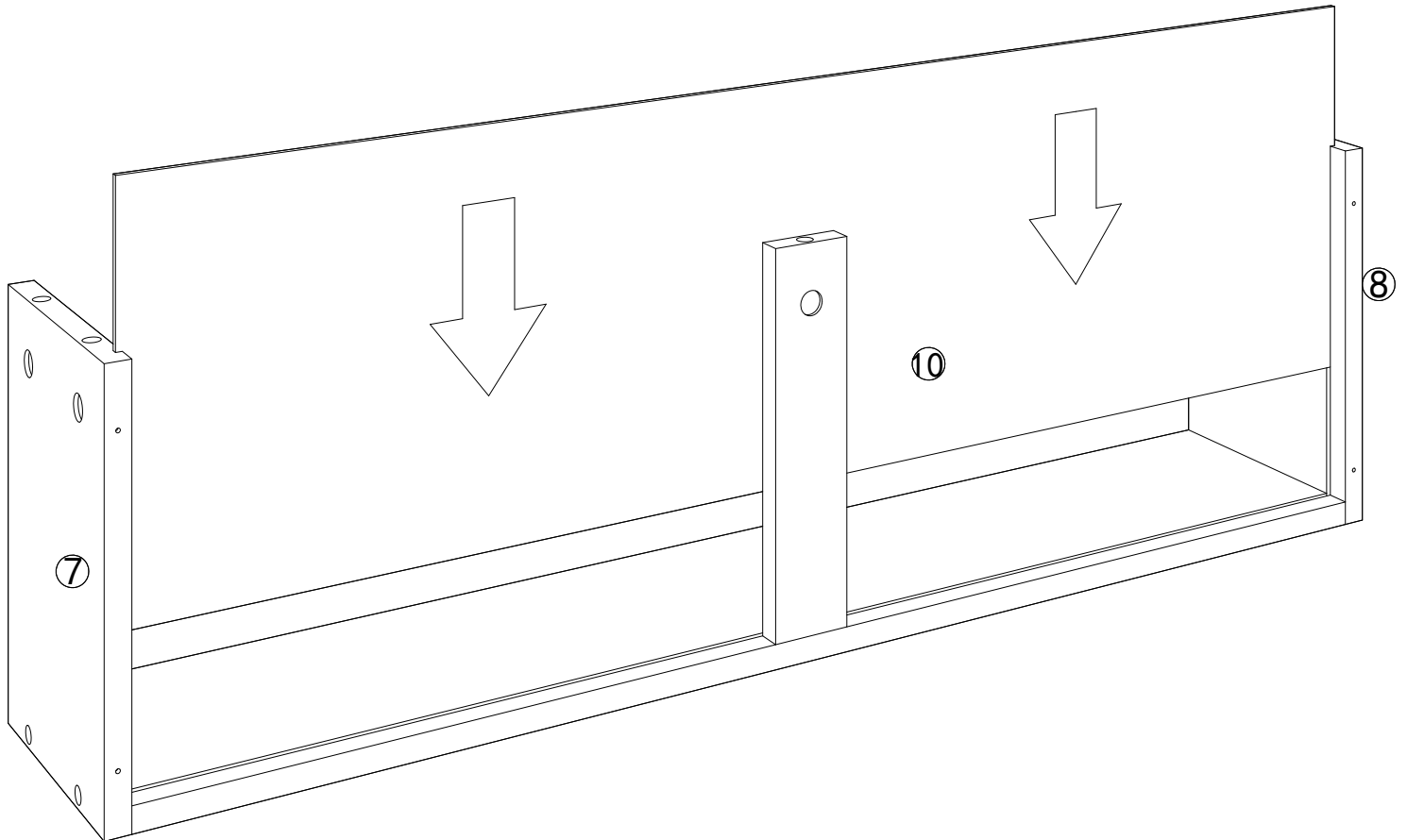

STEP 15



BX5

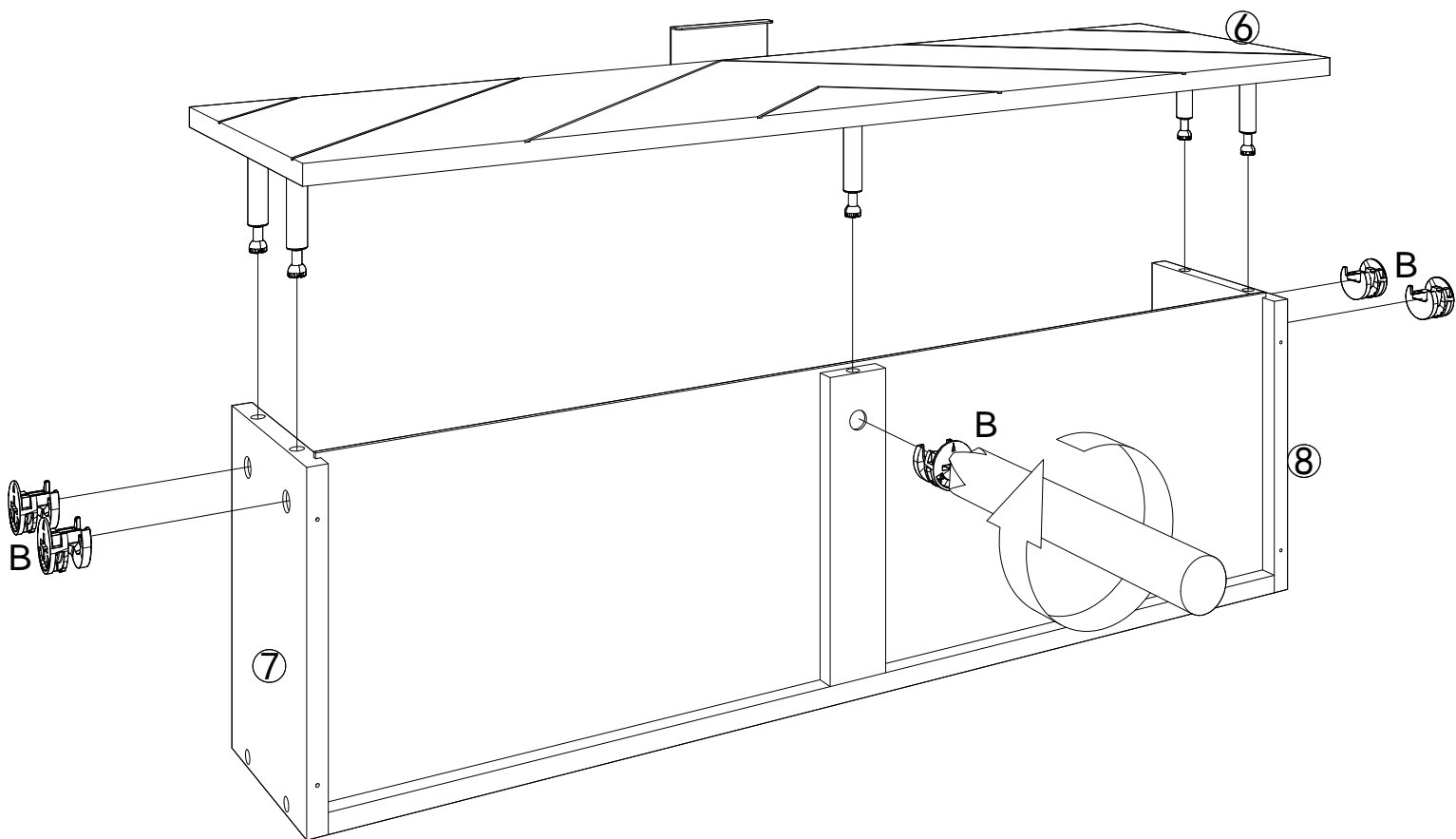

STEP 16

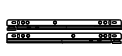

NX1



OX4

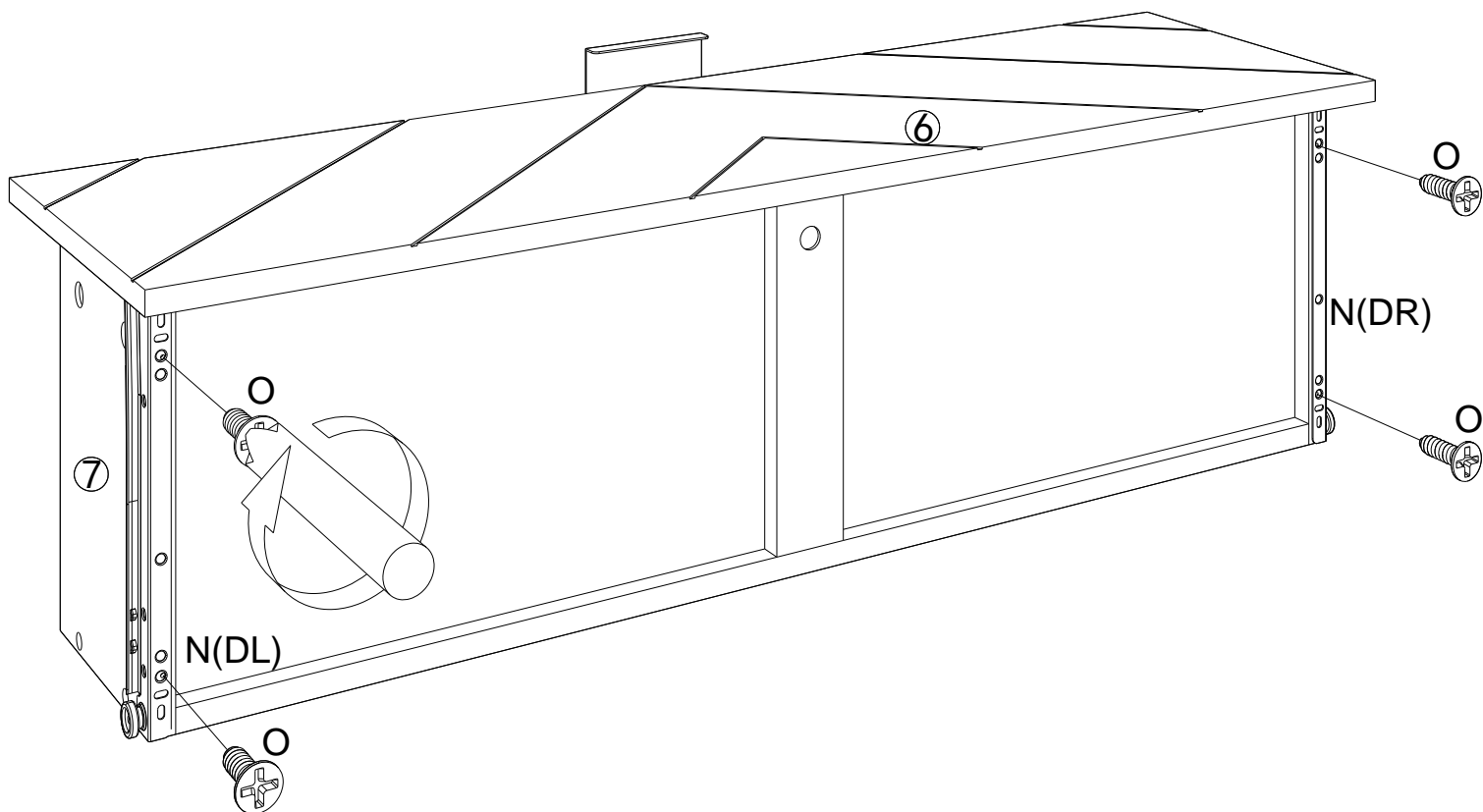

STEP 17

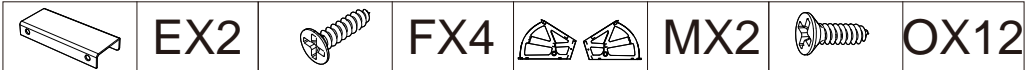

M(L)

M(R)

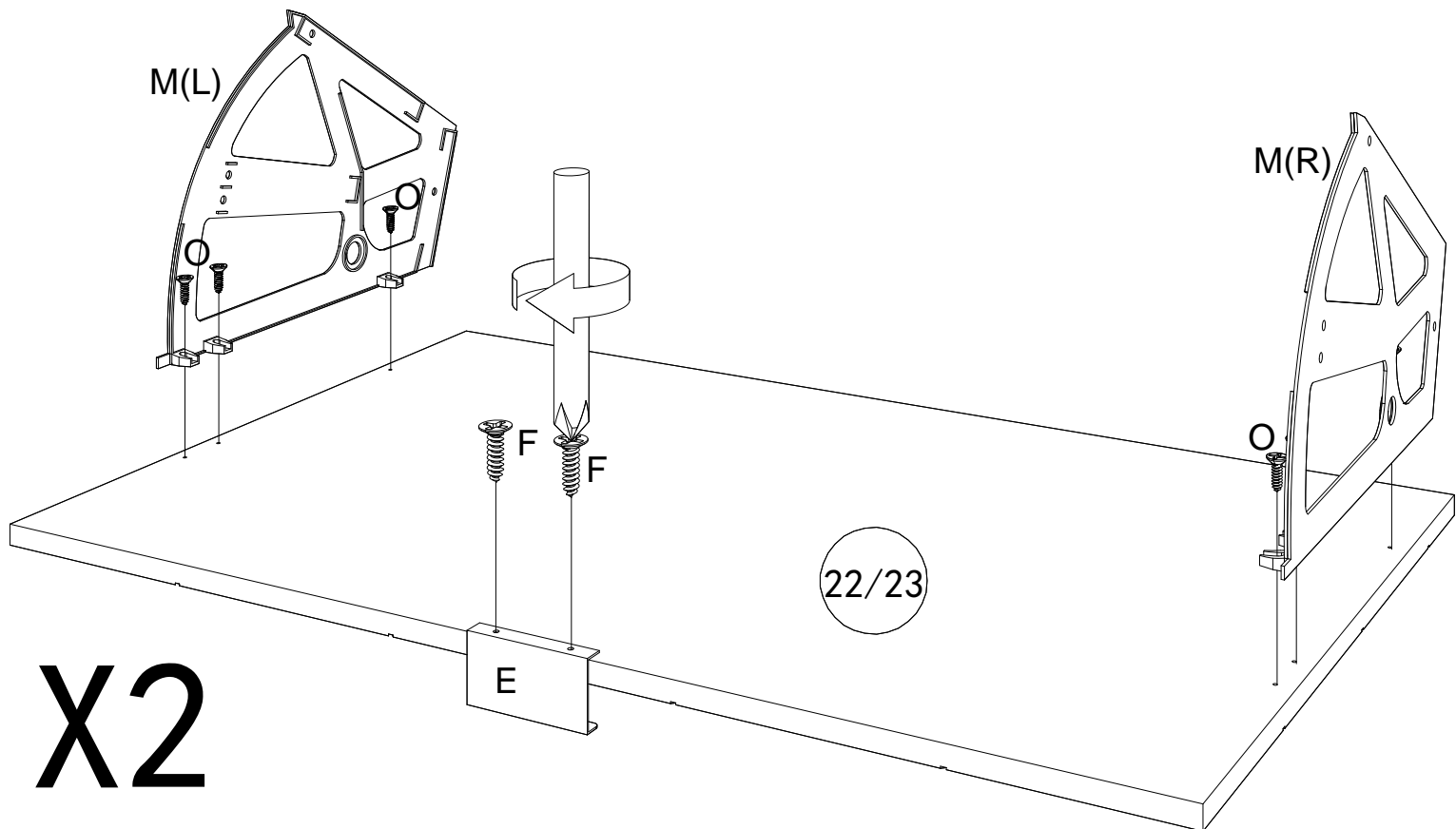

X2

STEP 18

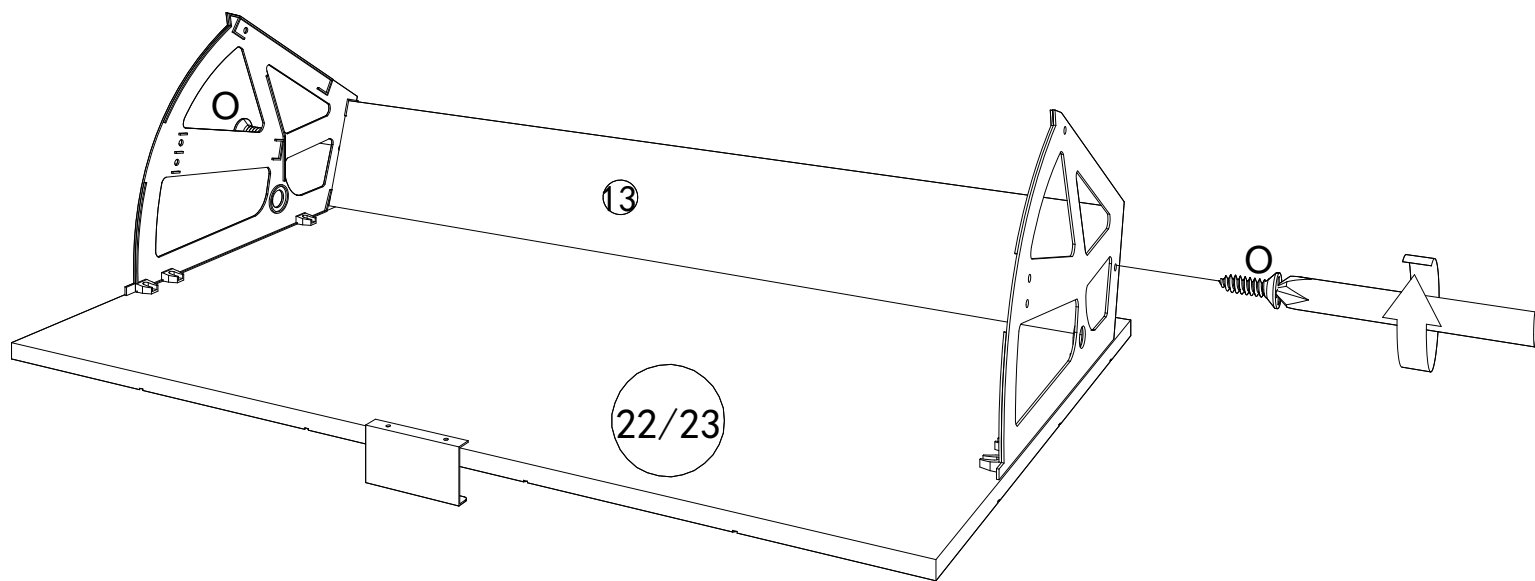

X2

STEP 19



OX4

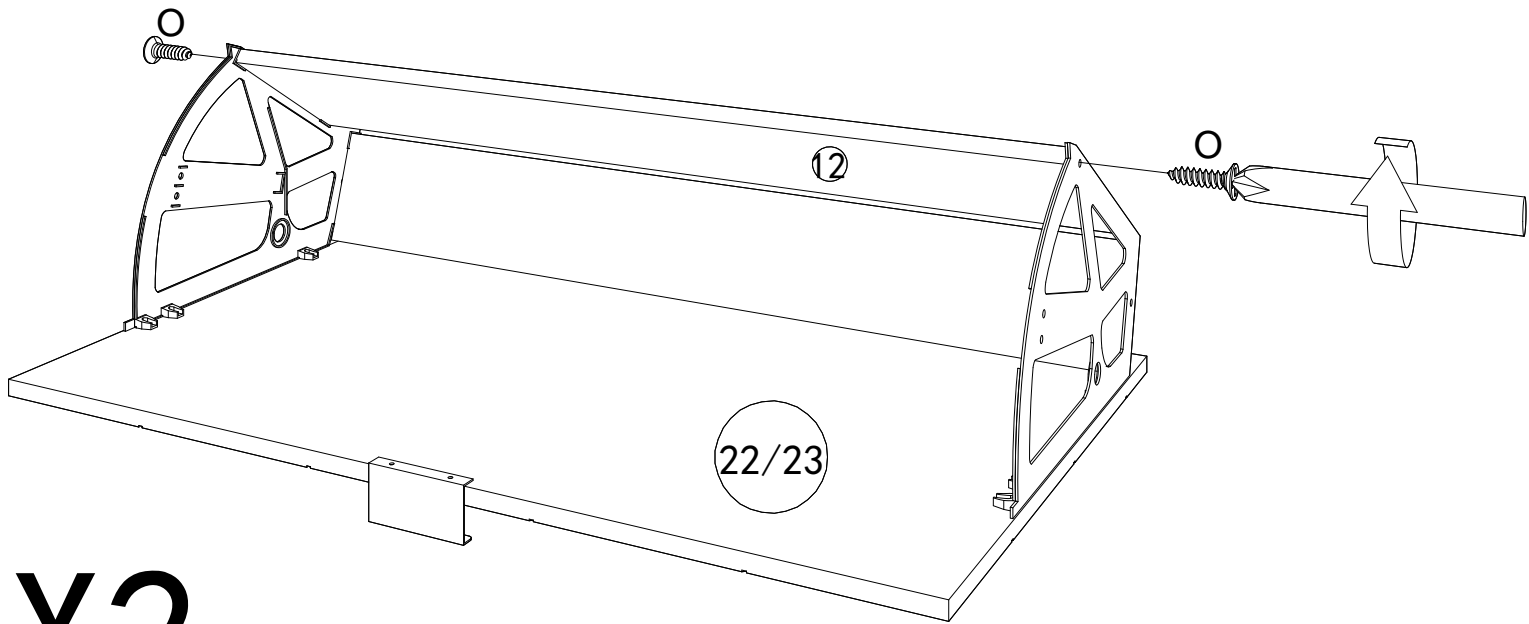

X2

STEP 20



SX1

WALL

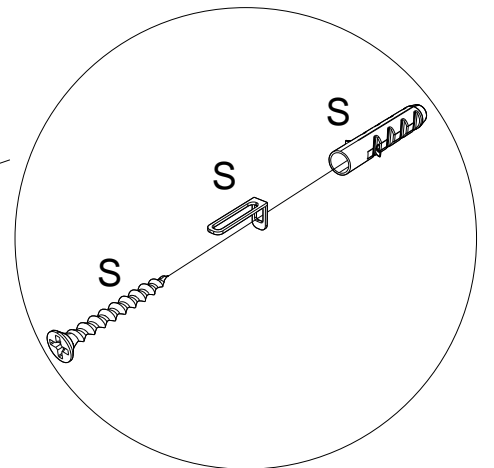
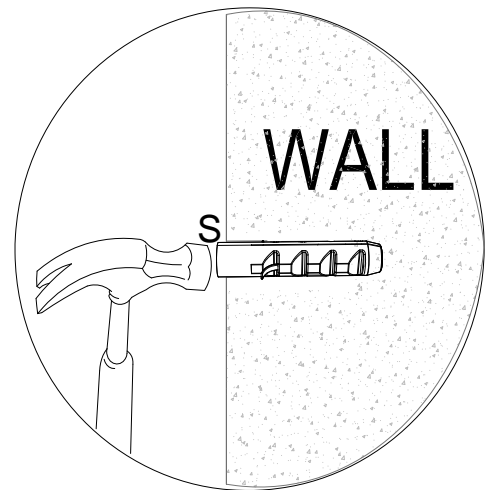
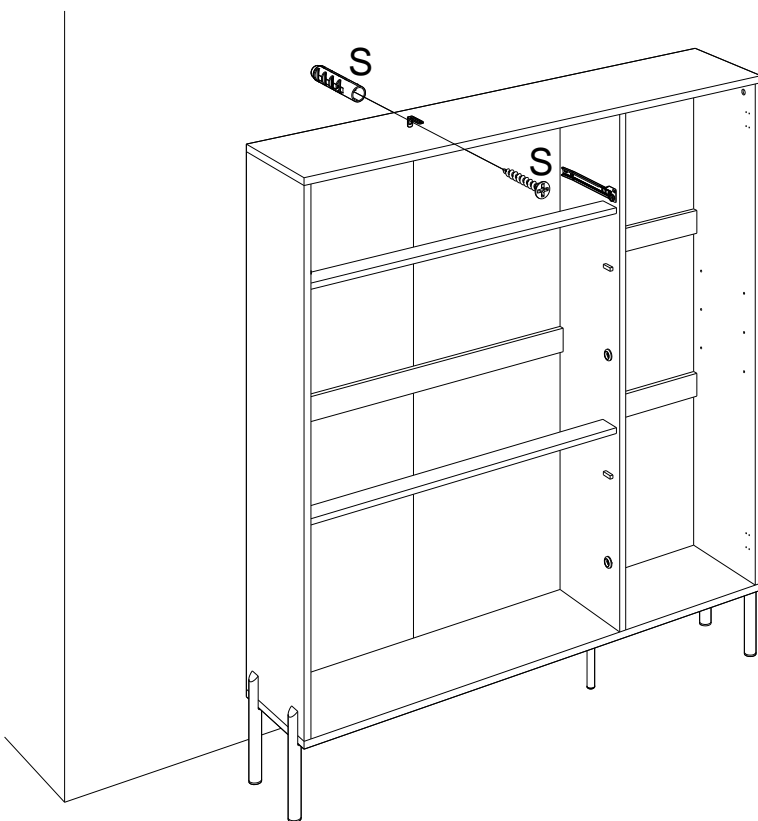

# STEP 21



KX4



LX4



For your product to be assembled more firmly ,Pls do not use the electric screwdriver at this step !!! Thanks much !

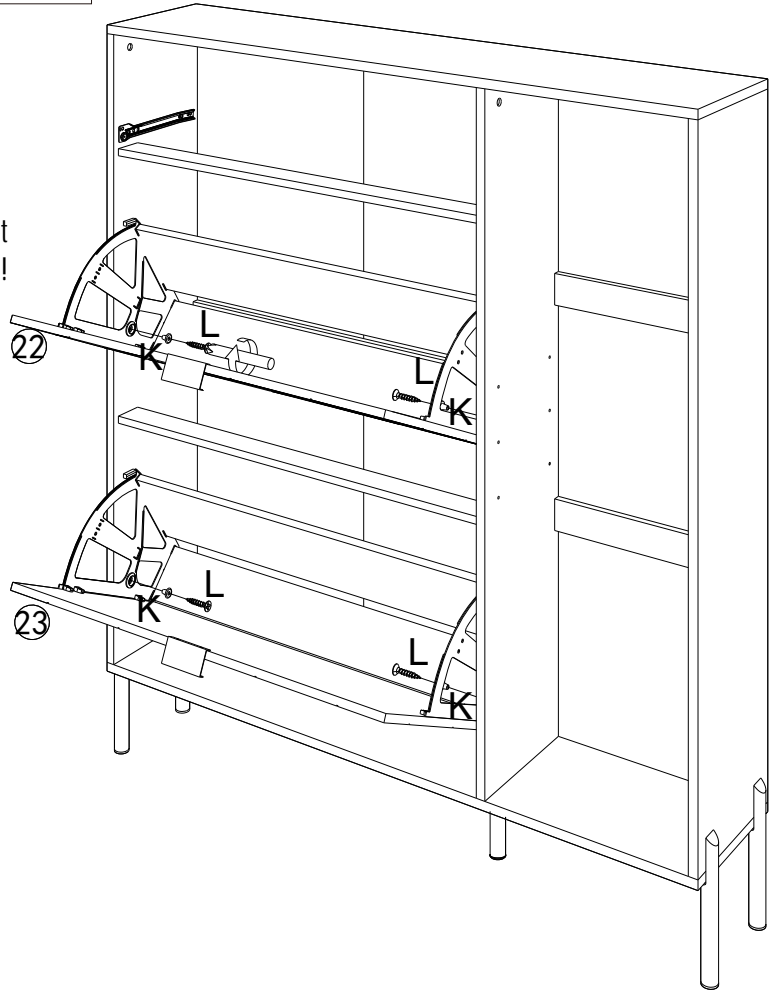
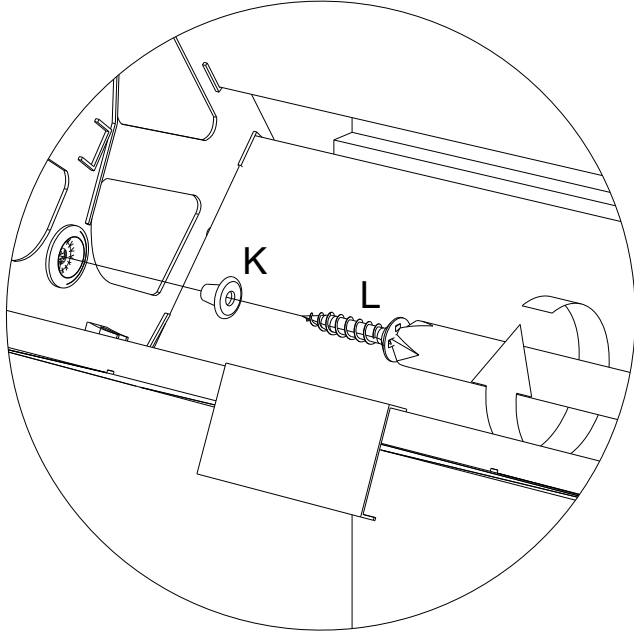

# STEP 22



OX4

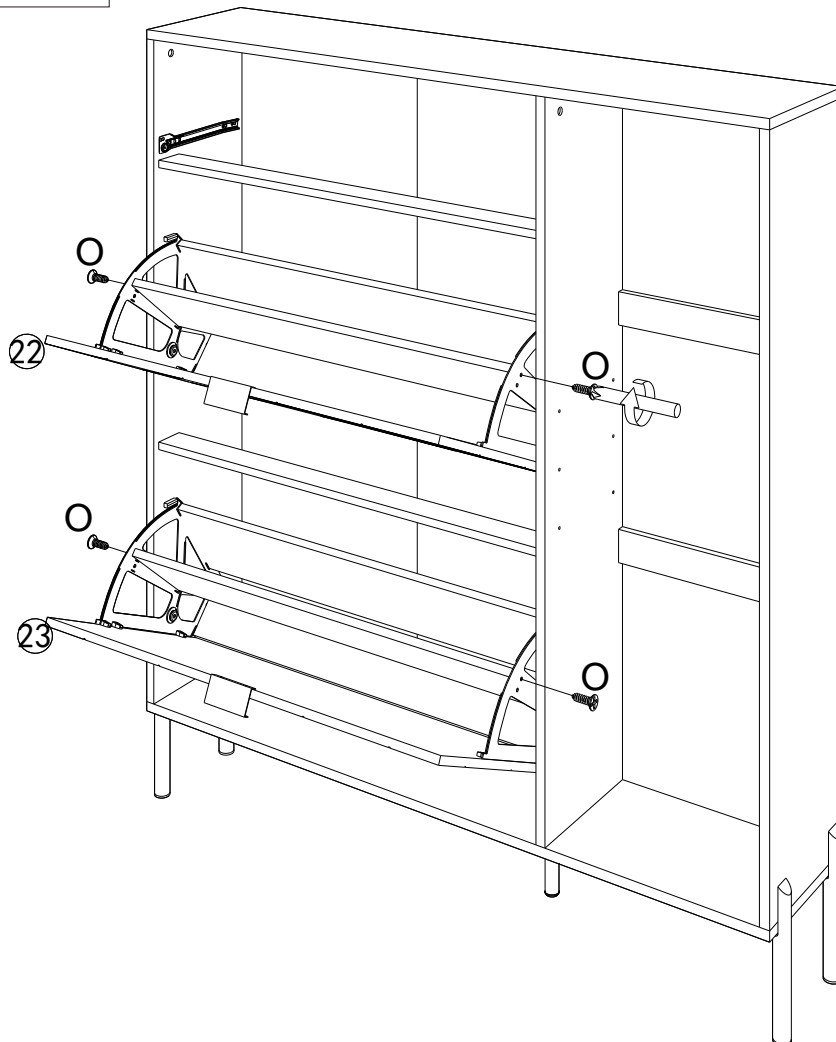

STEP 23



TX2



UX4

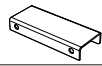

EX1



FX2

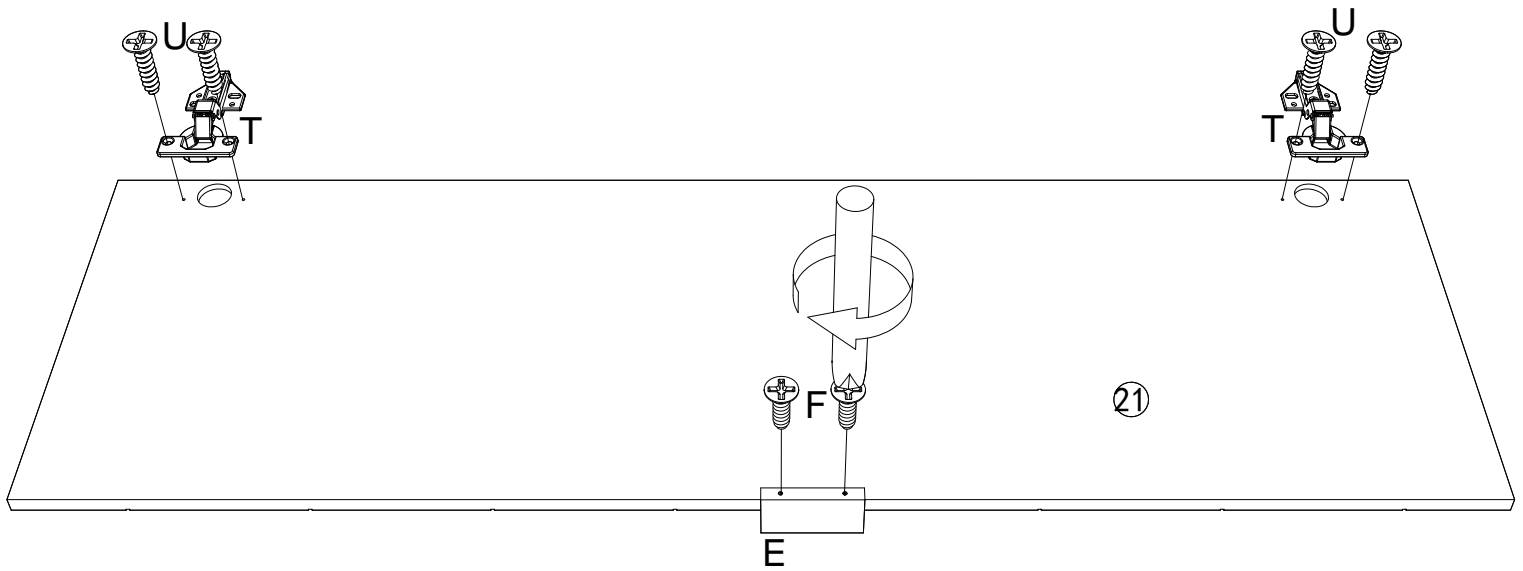

STEP 24

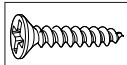

UX8

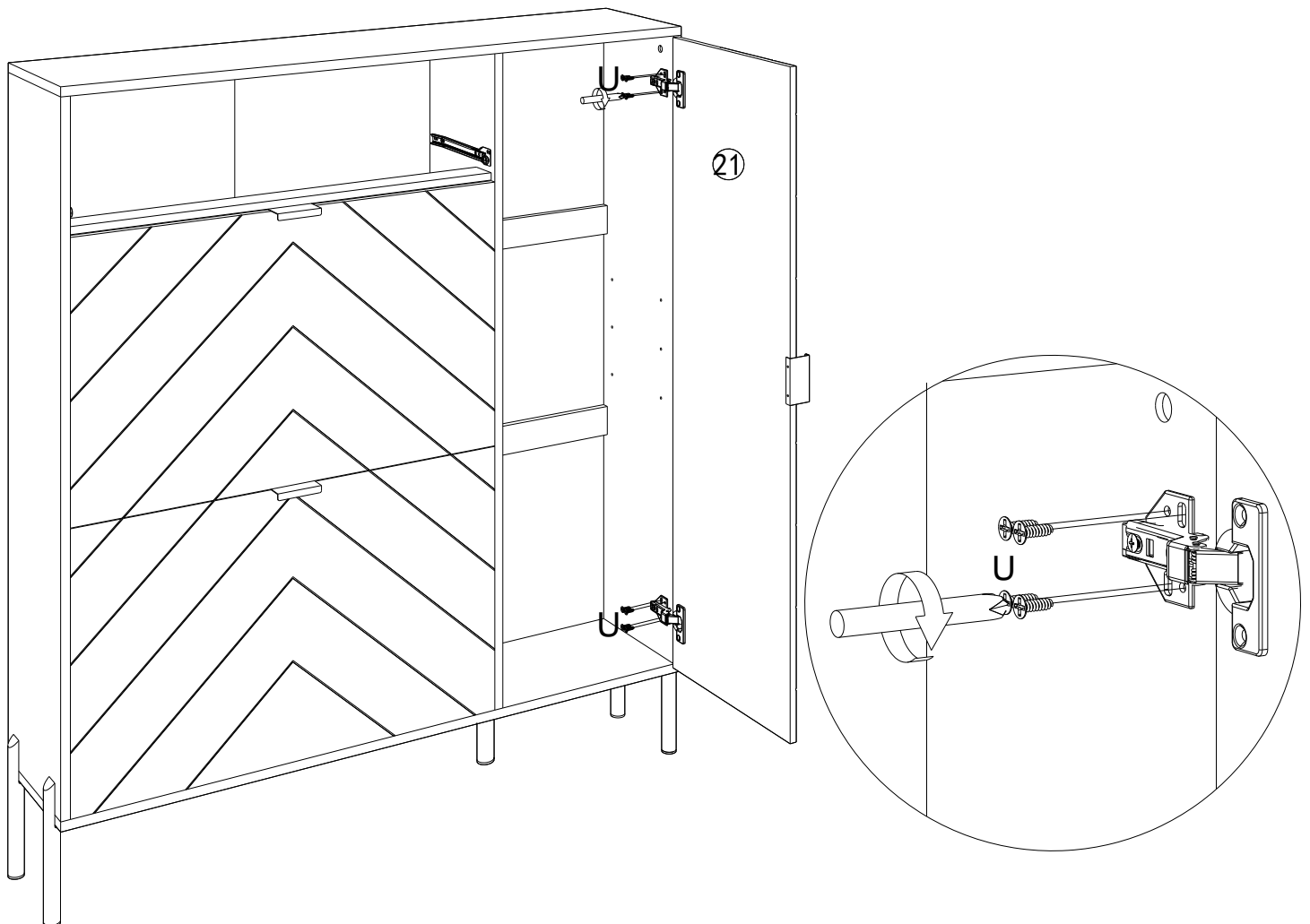

STEP 25



GX4



RX4

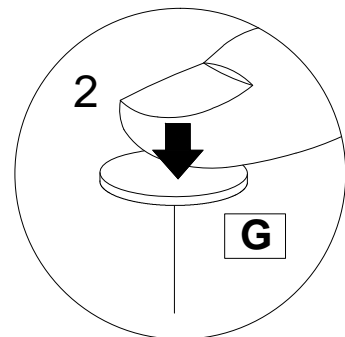
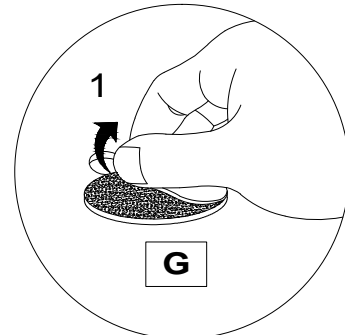
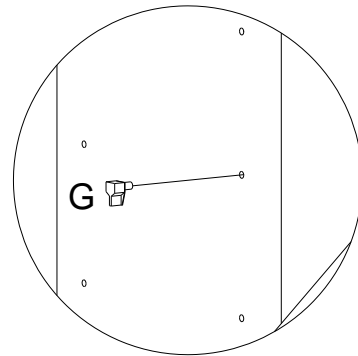
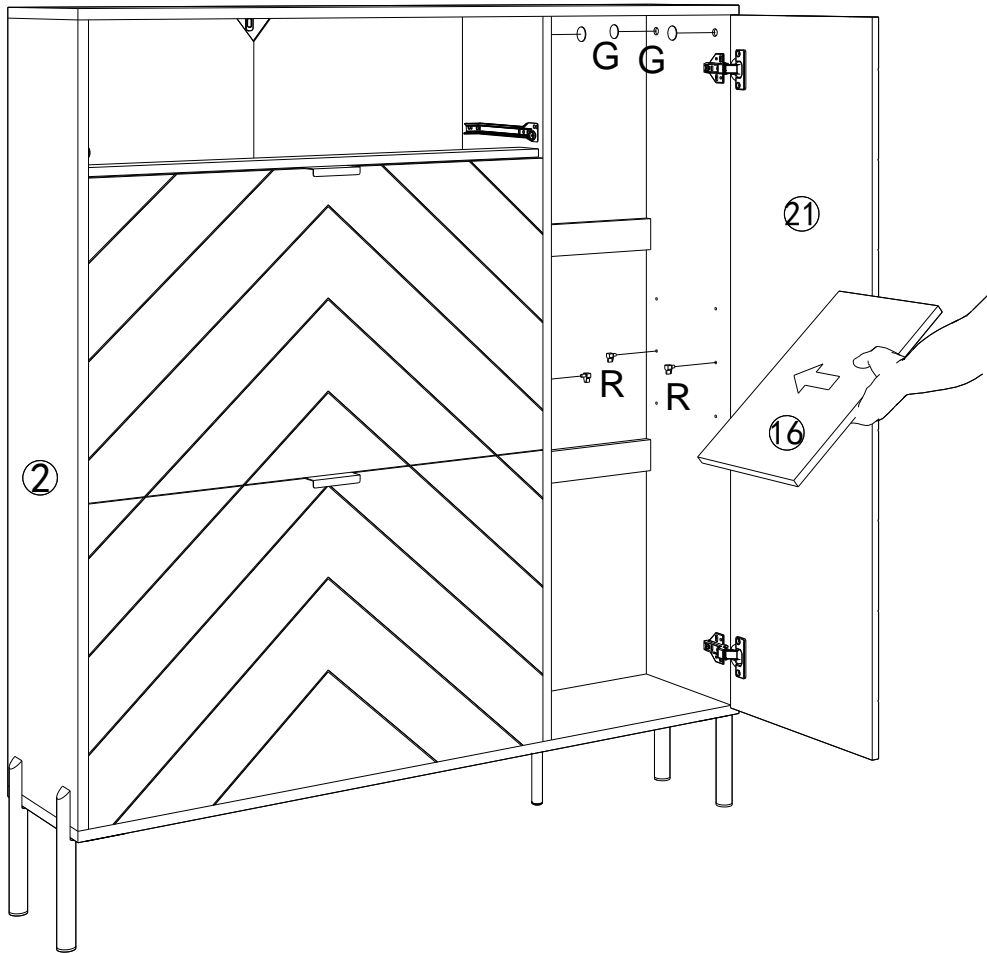

STEP 26

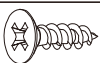

QX8



PX8

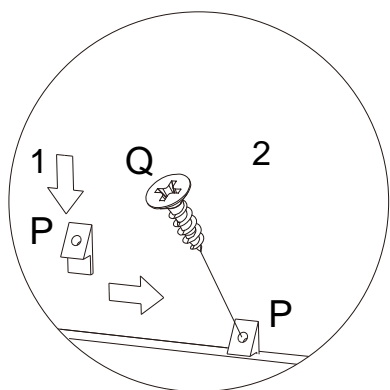
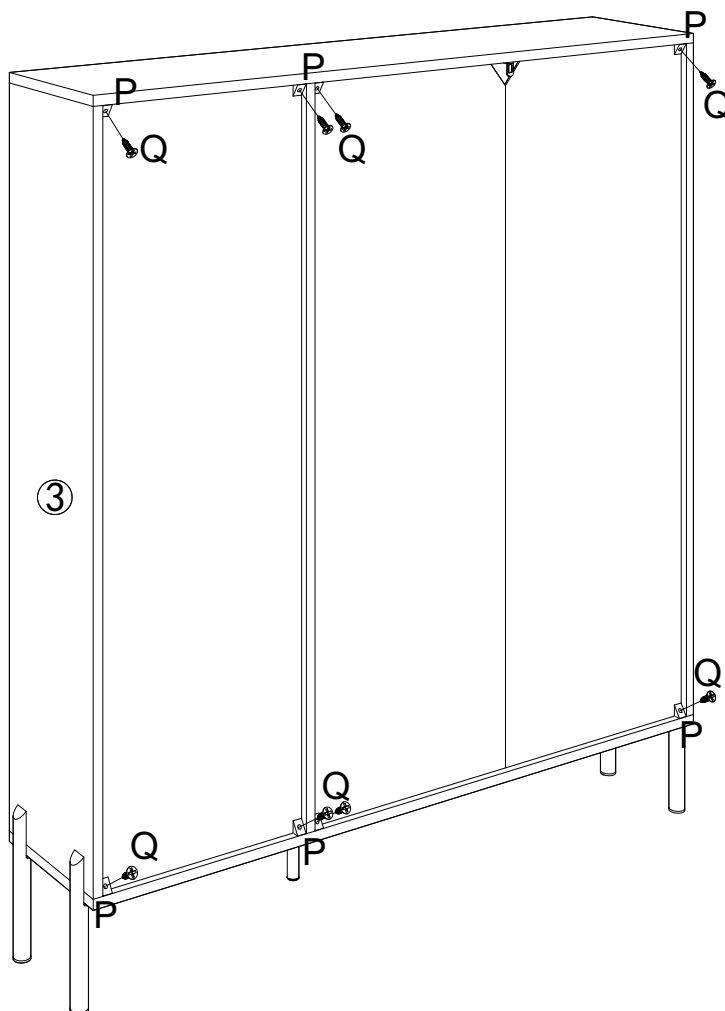

STEP 27

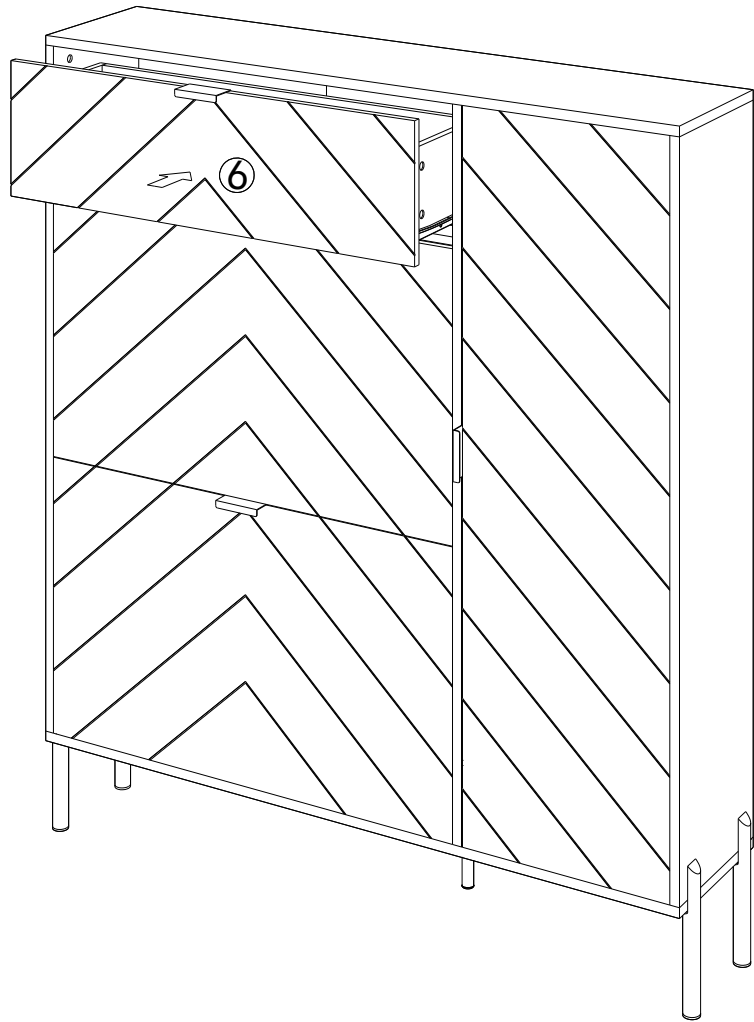
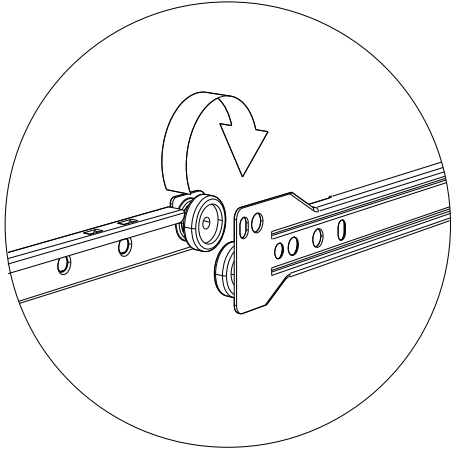

STEP 28

