

Picture 1

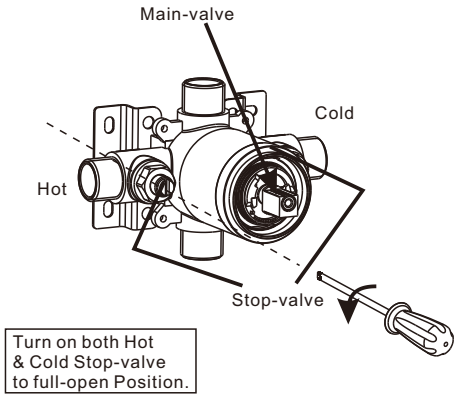

Picture 2

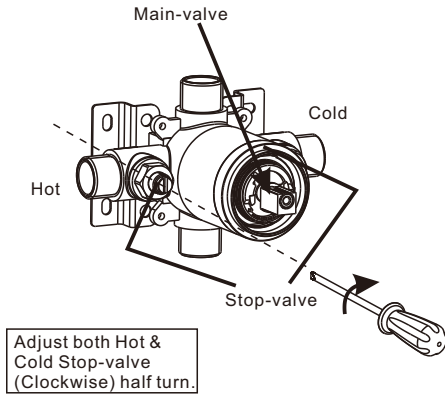

How to solve the issue of Spout & Shower running in the same time?

1. Disassemble the Handle & Escutcheon;
2. Make sure the Hot/Cold Stop-valve in Turn-on & also to full-open position (a djust by Phillips screwdriver), see below (Picture 1)
3. Turn on the Mian-valve with Spout function, if the shower stil dripping then, use screw driver to adjust both Hot & Cold Stop-valve (Clockwise) half turn, see below (Picture 2)
4. If the Shower keep dripping. try another half turn for both Hot & Cold side Stop-valve by Clockwise position.



B ↔ B

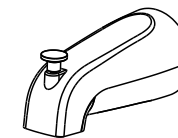
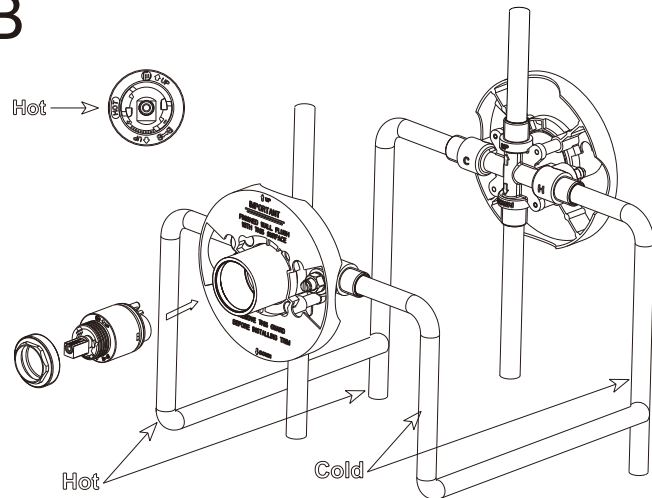

You may need to purchase:
 1/2" Female Threaded to
 1/2" PEX adapters
 1/2" PEX and Copper Couplings
 Crimp Rings
 1/2" Copper and PEX Tubing
 Torch and Lead-free Solder Kit

Safety tips

To avoid crushing and cutting injuries during assembly , gloves must be worn.
This product is only allowed for bath , hygiene and cleansing purposes.
Excessive pressure differences between hot and cold water pipes must be balanced.

Installation tips

Before installation , the product must be inspected for transportation damage.
After installation , transportation damage or surface scratches will not be recognized.
Pipes and valves must be installed , flushed , and inspected in accordance with common standards.
Please observe the current installation regulations in your country.
Use the relief valve only as specified .
Do not fix semi-dew columns and other components to the relief valve.
Do not use silica gel containing acetic acid during installation!

Technical parameters

Working pressure : max.1 Mpa
Recommended working pressure:0.1-0.5 Mpa
Test pressure:1.6 Mpa
(1Mpa=10bar=145 PSI)
Hot water temperature : up to 70°C
Recommended temperature:upto65°C
Thermal disinfection:max70°C/4minutes

Tips

- 1.Before installing the faucet , the debris in the pipeline must be washed away to avoid the pipeline being blocked.
- 2.Make sure that the pipes are left hot and right cold.

Install the cover, shower arm and shower head as below picture

Install the bathtub spout on the water pipe as the picture

Notice:
Before install the bathtub spout please be sure to polish the edge (Location A) of the copper pipe with sand paper, lest the copper pipe is too sharp to damage the inner sealing ring of the bathtub outlet.

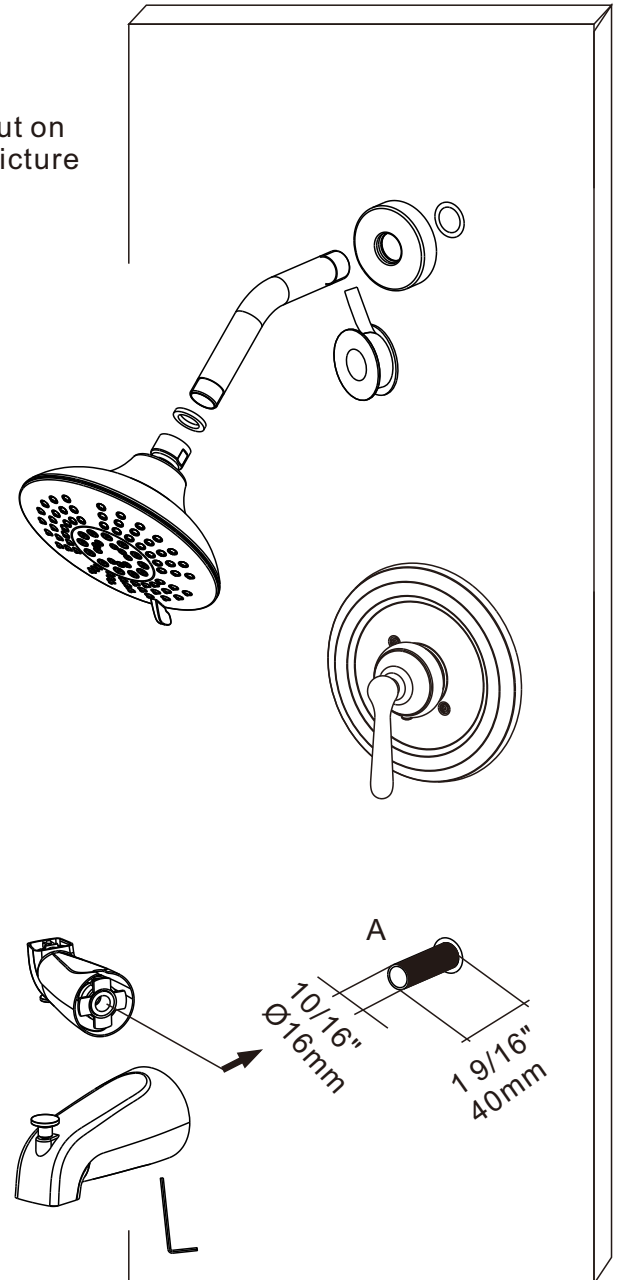

- 1.Remove the flange (part A) by hand.
- 2.Remove the valve gland (part B) by adjustable wrench.
- 3.Remove the cartridge (part C) and open the inlet valve to rush the silt in the pipe.
- 4.Keep the water flowing for one minute to check the pipe. connection position is leaking.

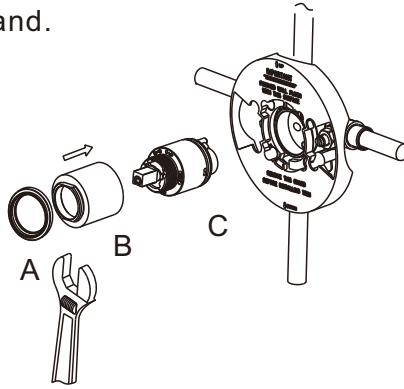

As shown in the figure, please close the main valve of Entrance water pipe.

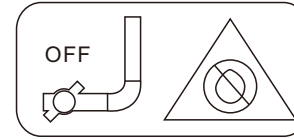

- 1.Reinstall the cartridge , then install the panel on the valve.
- 2.install the valve trim by screwdriver.

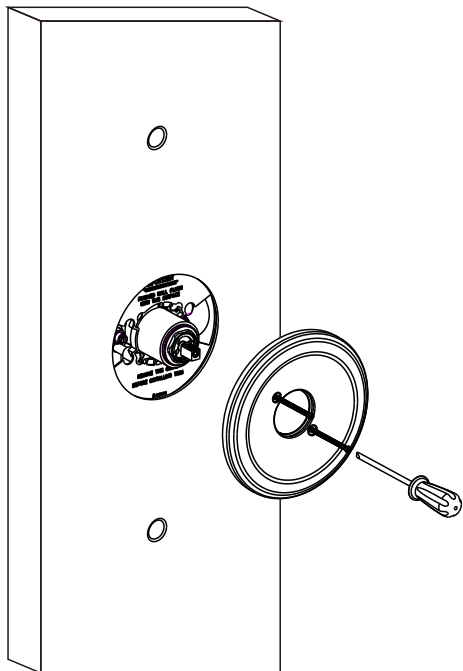

Install the handle with Allen key as below picture

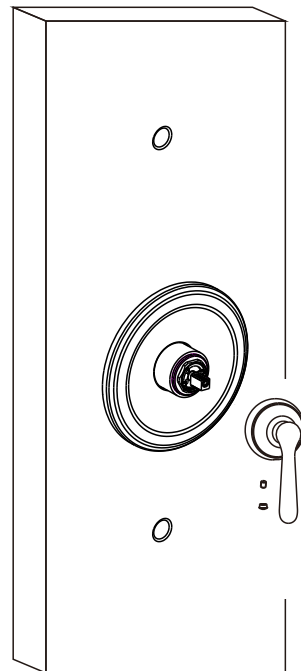

Drill three holes in the wall

according to the drawing:
A:Pressure balance valve hole
B:Top spray hole
C:Bathtub spout hole

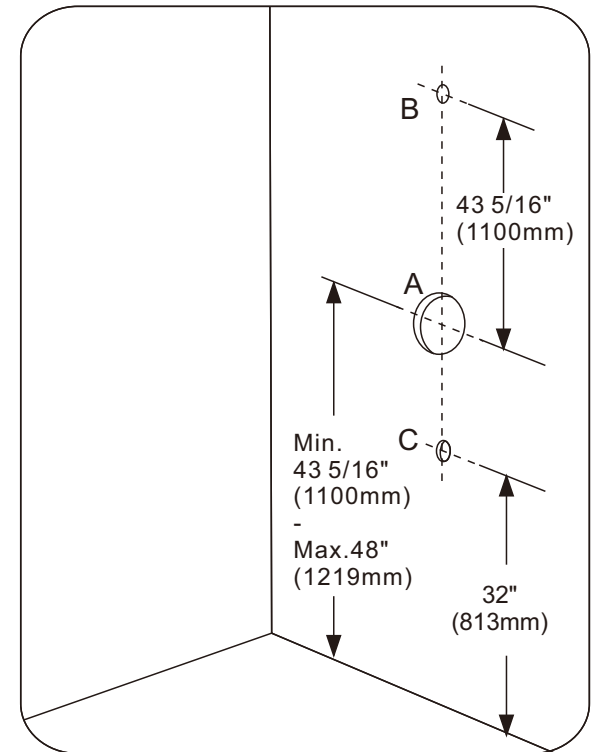

unit:inch (mm)

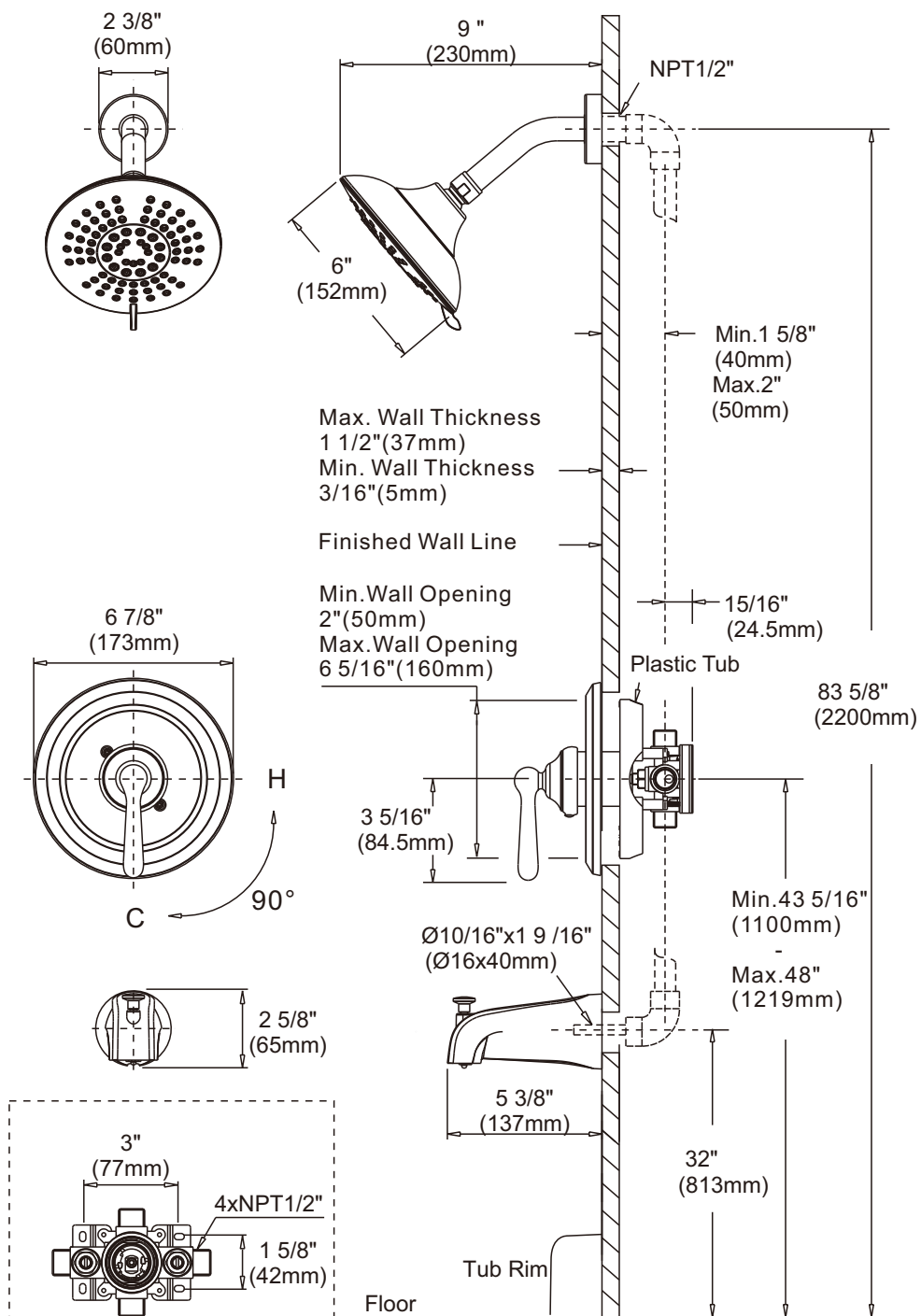

Connect the valve to the pipes as the right picture
Identify the markings on the back of valve body.

UP marking :
Connect the top spray pipe in the wall.

DOWN marking :
Connect the bathtub spout pipe in the wall.

H marking :
Connect the hot water pipe in the wall.

C marking :
Connect the cold water pipe in the wall.

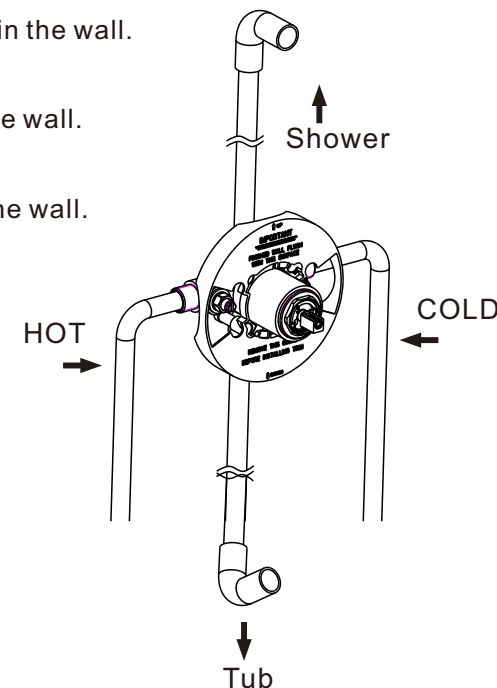
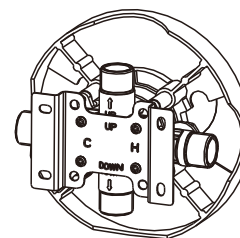

As mandated by U.S. federal law ,this showerhead is equipped with water flow regulator that limits maximum water flow to 1.8 GPM (6.8 liters) per minute at 80 psi water pressure .

In areas with extremely low water pressure causing the shower water flow to be unsatisfactory , the flow regulator may be removed to improve the water flow in the shower head.

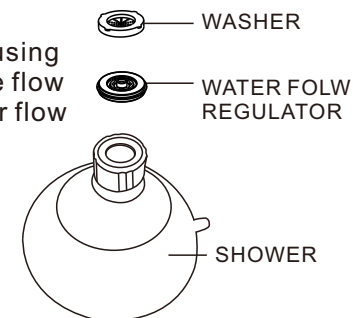

Using screwdriver point or long nose pliers, pull out Water Regulator located inside Shower Handle.