

ASSEMBLY INSTRUCTION

TUFTED FULL BED - HEADBOARD

A lower part of Headboard

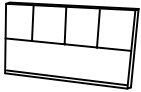

1 pc

B upper part of Headboard

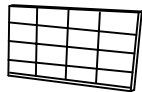

1 pc

C Wooden Leg

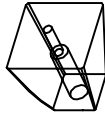

2 pcs

D Bolt
1/4" x 75mm



2 pcs

E Bolt
1/4" x 50mm



10 pcs

F Flat Washer



12 pcs

G Lock Washer



12 pcs

H Allen Wrench



1 pc

I Slate

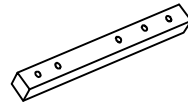

2 pcs

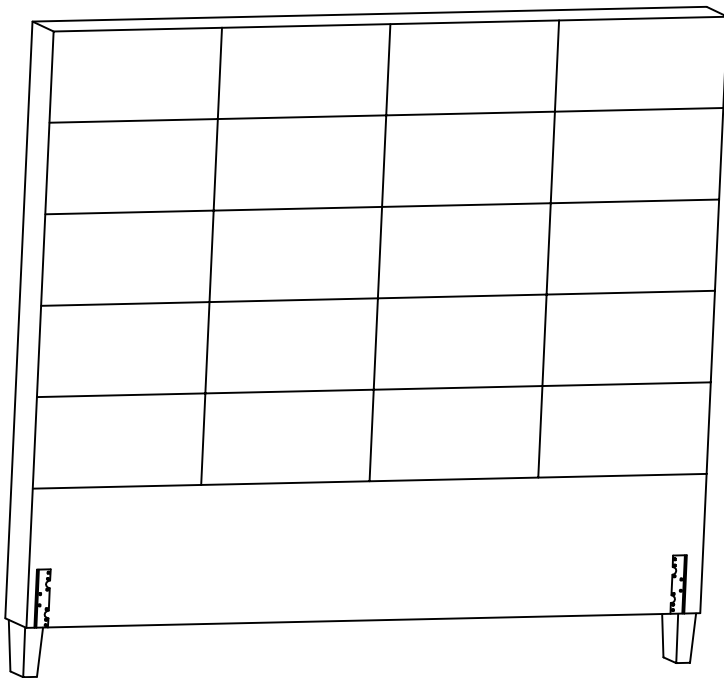

This page lists all the contents included in the box. Please take the time to identify the hardware as well as the individual components to this product. As you unpack and prepare for assembly, place the contents on a carpeted or padded area to protect them from damage.

1

Attached Headboard (A)(B) use Bolt (E), Lock Washer (G) and Flat Washer (F) on holes of Slates (I). Turn the Allen Wrench (H) in Bolt (E).

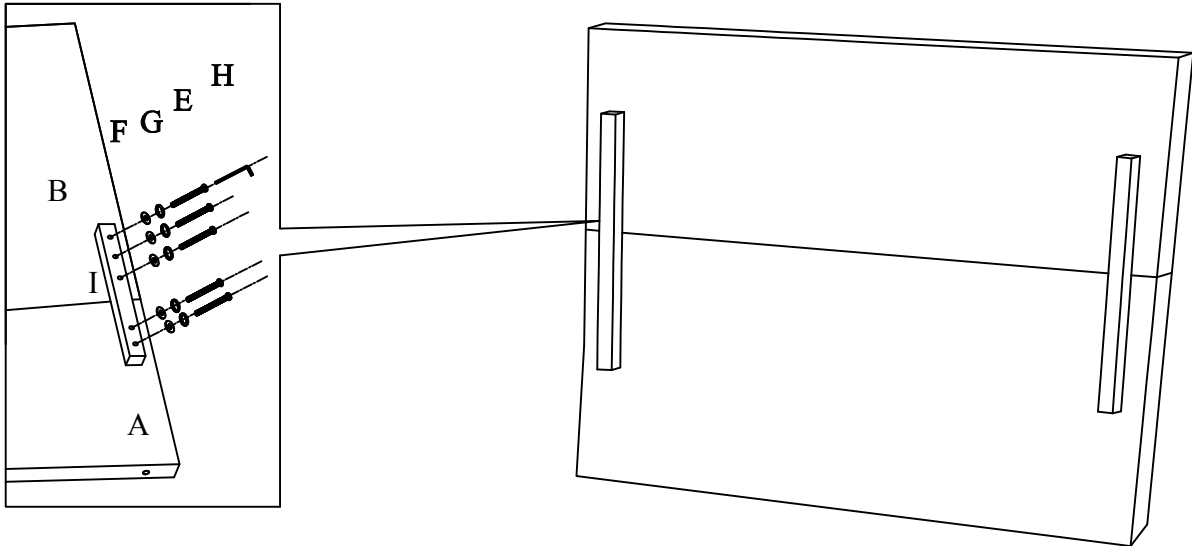
**2**

Attached Wooden Leg (C) to the Headboard (A) use Bolt (D), Lock Washer (G) and Flat Washer (F) on both of holes. Turn the Allen Wrench (H) in Bolt (D).

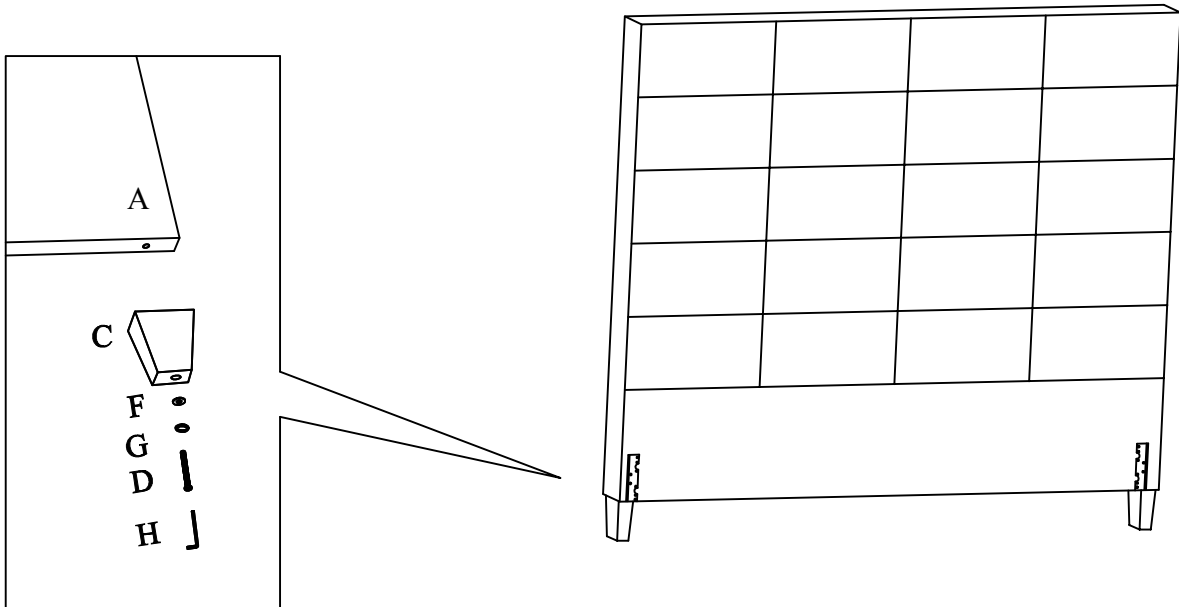

Cleaning & Care

Treat surface with care. Surface is resistant to scratches but is not scratch resistant. Clean surfaces with a dry or damp soft cloth. Do not use abrasive cleaners. Hardware may loosen over time. Periodically check that all connections are tight.

ASSEMBLY INSTRUCTION

TUFTED FULL BED - FOOTBOARD & SIDE RAILS

A Footboard

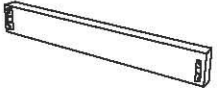

1 pc

B Side Rails



2 pcs

C Wooden Leg

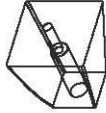

2 pcs

D Support Leg



6 pcs

E Wooden Slat

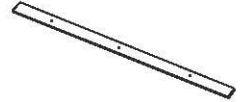

3 pcs

F Screw



12 pcs

G Bolt
1/4" x 75mm



2 pcs

H Bolt
1/4" x 50mm



6 pcs

I Flat Washer

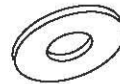

8 pcs

J Lock Washer

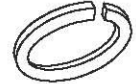

8 pcs

K Allen Wrench



1 pc

This page lists all the contents included in the box. Please take the time to identify the hardware as well as the individual components to this product. As you unpack and prepare for assembly, place the contents on a carpeted or padded area to protect them from damage.

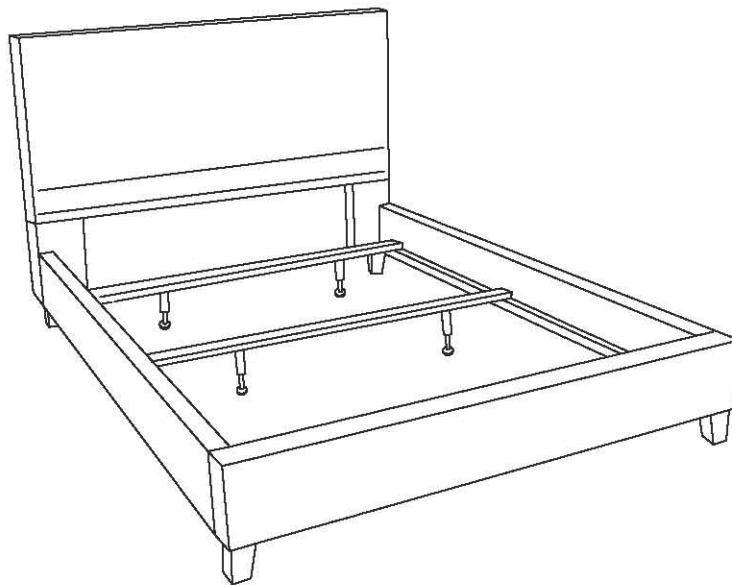

- 1** Attached Wooden Leg(C) to the Footboard(A) use Bolt(G), Lock Washer(J) and Flat Washer(I) on both of holes. Turn the Allen Wrench(K) in Bolt(G).

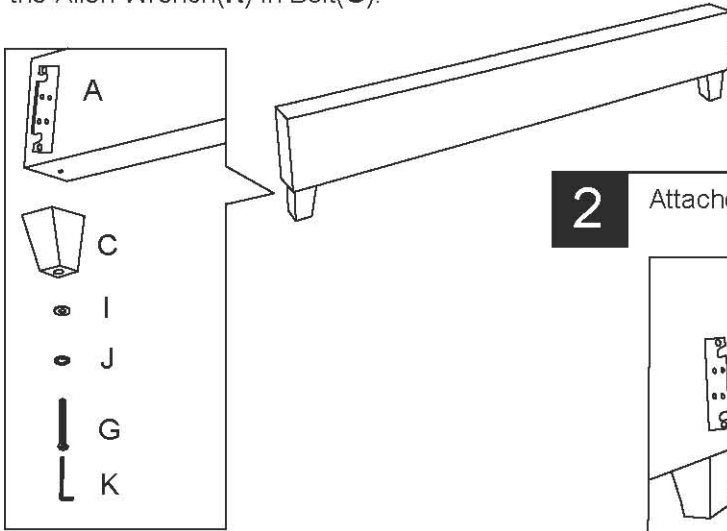

- 2** Attached Side Rail(B) to the Headboard and Footboard(A).

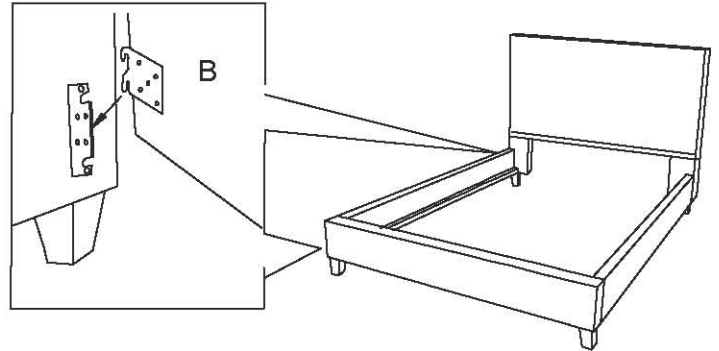

- 3** Assembly Wooden Slats(E) and Support Leg (D) as showing.

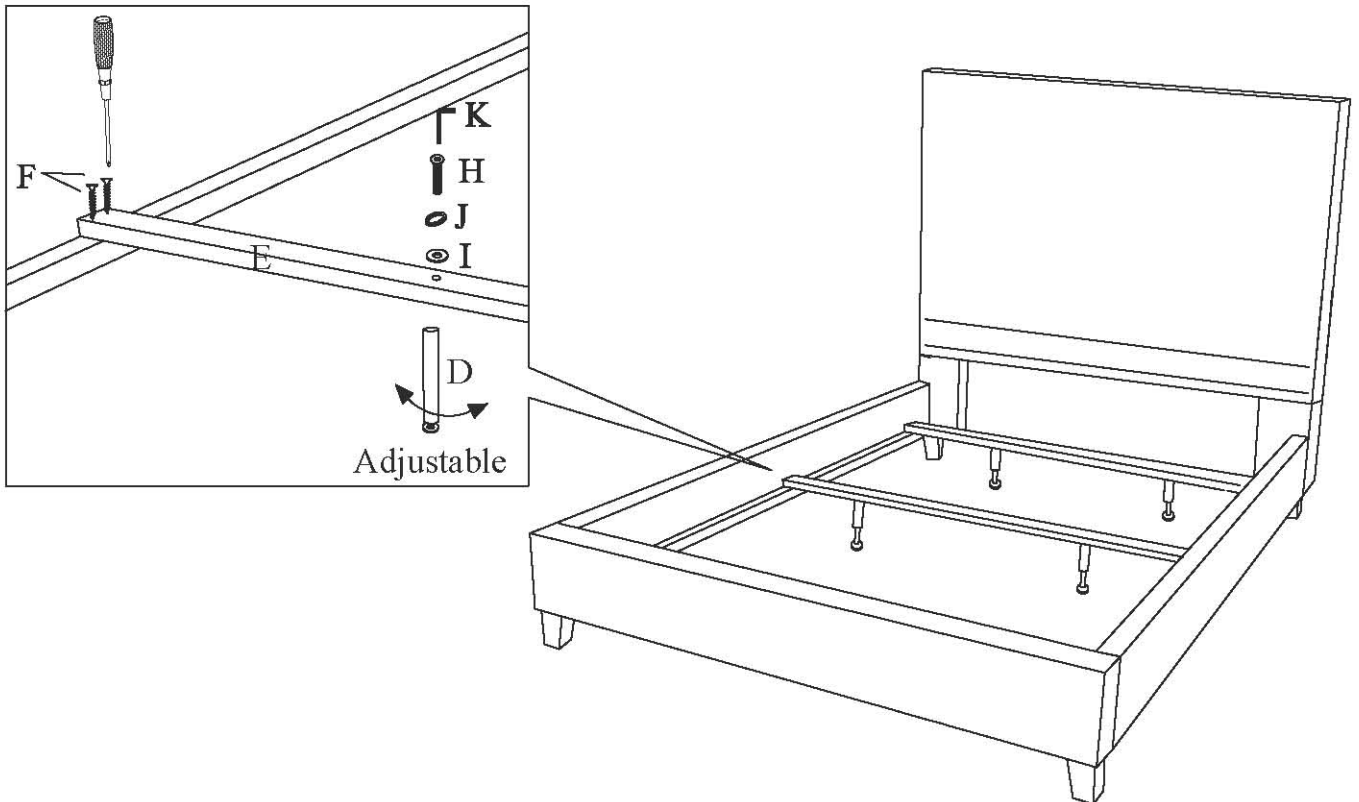

Cleaning & Care

Treat surface with care. Surface is resistant to scratches but is not scratch resistant. Clean surfaces with a dry or damp soft cloth. Do not use abrasive cleaners. Hardware may loosen over time. Periodically check that all connections are tight.