



Receiving Instructions

After delivery, remove the packaging from the product. Inspect the product closely to determine whether it sustained damage during transport. If damage is discovered, record a complete description of it on the bill of lading. If the product is undamaged, discard the packaging.

NOTE: The end-user is solely responsible for confirming that product design, use, and maintenance comply with laws, regulations, codes, and mandatory standards applied where the product is used.

Table of Contents	Page
Specifications.....	2
Signal Words.....	3
Safety Instructions.....	3
Exploded Views & Bills of Materials.....	4
Product Overview.....	4
Parts and Hardware.....	5
Tools Required.....	5
Assembling the Folding Step.....	5 - 7
Installing the Folding Step.....	8
Record of Satisfactory Condition.....	8
Inspecting and Maintaining the Folding Step.....	9
Labeling Diagram.....	9
Limited Warranty.....	10

SPECIFICATIONS

STEEL FOLD UP STEP

APPROX WEIGHT: 11.08 lbs.
DOES NOT INCLUDE WEIGHT OF POWER OR PACKAGING!!!

*** ANY ADDITIONS, DELETIONS, OR OMISSIONS MUST BE CORRECTED ON THIS DRAWING AS THIS DRAWING WILL BE CONSIDERED ALL INCLUSIVE ***
ALL GRAPHICS PROVIDED ARE FOR REFERENCE ONLY. IF CERTAIN DIMENSIONS ARE CRITICAL PLEASE VERIFY THOSE DIMENSIONS WITH YOUR SALESPERSON

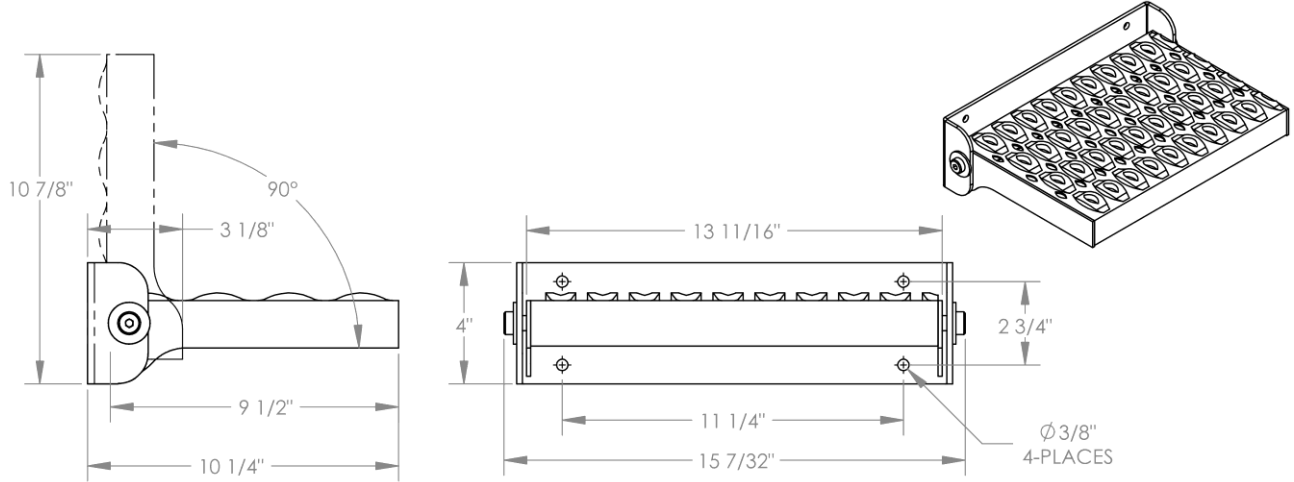

DIMENSION TOLERANCE $\pm 1/4$ "

STANDARD FEATURES

- OVERALL WIDTH IS 15 7/32"
- STEP WIDTH IS 13 11/16"
- OVERALL LENGTH IS 10 1/4"
- STEP DEPTH IS 9 1/2"
- OVERALL HEIGHT IS 4"
- FOLDED HEIGHT 10 7/8"
- FOLDED WIDTH 3 1/8"
- MAX LOAD 350 LBS
- DURABLE BAKED IN POWDER COAT BLUE FINISH



SPECIAL FEATURES

NONE

A P P R O V A L	I, THE UNDERSIGNED, AGREE THAT THE PRODUCT AS REPRESENTED SATISFIES DESIGN AND DIMENSION REQUIREMENTS. I ALSO ACKNOWLEDGE MY DUTY TO CONFIRM PRODUCT AND INSTALLATION COMPLIANCE WITH ALL APPLICABLE FEDERAL, STATE AND LOCAL REGULATIONS AND STANDARDS.		
	UNITS REQUIRING APPROVAL DRAWINGS OR MODIFIED ARE NON-RETURNABLE		
	[] As drawn [] As marked		
	Signed: _____ Date: _____		
Printed Name: _____			
LEAD TIME WILL START UPON RECEIPT OF SIGNED APPROVAL DRAWING			
DISTRIBUTOR'S NAME:		P.O.#	X
MANUFACTURING		W.O.#	X
DRAWN BY:	F.S.	DATE:	04/18/14
REFERENCE:	X	SCALE:	1:4
QUOTED LEAD TIME:	X	QUOTE #	X
		SALES:	X
		FILE NAME:	

SIGNAL WORDS

This manual uses SIGNAL WORDS to indicate the likelihood of personal injuries, as well as the probable seriousness of those injuries, if the product is misused in the ways described. Other signal words call attention to uses of the product likely cause property damage. The following are signal words used in this manual and their definitions.

 DANGER	Identifies a hazardous situation which, if not avoided, WILL result in DEATH or SERIOUS INJURY . Use of this signal word is limited to the most extreme situations.
 WARNING	Identifies a hazardous situation which, if not avoided, COULD result in DEATH or SERIOUS INJURY .
 CAUTION	Indicates a hazardous situation which, if not avoided, COULD result in MINOR or MODERATE injury.
NOTICE	Identifies practices likely to result in product/property damage, such as operation that might damage the product.

SAFETY INSTRUCTIONS

We strive to identify foreseeable hazards associated with the use of its products. However, no manual can address every conceivable risk. The most effective way to avoid injury is to exercise sound judgment when installing, using, inspecting, and maintaining this product.

WARNING

Risks of serious personal injuries or death.

- **Read and understand the entire manual before installing, using or servicing your step.** Keep this manual in a location known to persons who use the step. Read the manual regularly to refresh your understanding of use, inspection, and maintenance procedures.
- Improper installation or use may result in injury or property damage. **DO NOT** install the step with inadequate fasteners. The step should only be attached to sturdy surfaces that are capable of supporting the combined weight of the step and a maximum rated load (350 pounds; 159kg)
- Keep clear of pinch points while folding the step. Model includes a spring to automatically fold the step to its normally closed position as soon as weight is removed from the step surface.
- **DO NOT** use the step unless it is in satisfactory condition. Inspect it as instructed in the [INSPECTING & MAINTAINING THE FOLDING STEP](#) section on [p. 9](#). To determine whether the unit is in satisfactory condition.
- The serrated surface provides extra traction, but caution is advised in wet or slippery conditions.
- **DO NOT** modify this product in any way. Modifications automatically void the [LIMITED WARRANTY](#) on p. 10, and might make the step unsafe to use.

NOTICE

Regular maintenance is essential for this product to function safely, properly, and for as long as possible.

- Do not use this folding step in (OSHA) classified environments.
- Keep the product clean & dry. Remove rust and apply touchup paint to all areas where the finish is damaged as soon as damage is noticed.
- Only use manufacturer-approved replacement parts. To order replacement or spare parts for this step, contact the [TECHNICAL SERVICE](#) department. Contact information for the [TECHNICAL SERVICE AND PARTS DEPARTMENT](#) is provided on the cover page of this manual.

EXPLODED VIEW:

Item	Part no.	Description	Qty.
1	23-514-089	STEP WELDMENT	1
2	23-016-084	BRACKET, MOUNTING PLATE, FORMED	1
3	26347	SOCKET HEAD SHOULDER BOLT, GRADE 2, Ø1/2 x 5/8 LG	2
4	33012	FLAT WASHER, LOW CARBON, ZINC FINISH, 1/2"	4
5	37024	NYLON INSERT LOCK NUT, GRADE 2, ZINC FINISH, 3/8"-16	2

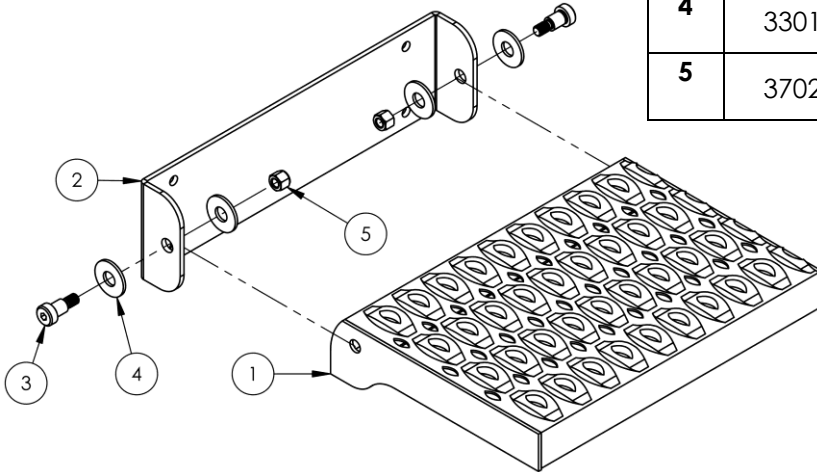

EXPLODED VIEW:

Item	Part no.	Description	Qty.
1	23-016-110	BRACKET, MOUNTING PLATE, FORMED	1
2	23-514-114	STEP WELDMENT	1
3	23-146-001	SPRING, TORSION	1
4	26350	SHSB, GRADE 2, 1/2x1 SHOULDER, 3/8-16 UNC THREAD	1
5	33086	FLAT WASHER, ZINC PLATED, SAE, Ø1/2" x 1.062OD	5
6	37024	NYLON INSERT LOCK NUT, GRADE 2, ZINC FINISH, 3/8"-16	2
7	26347	SOCKET HEAD SHOULDER BOLT, GRADE 2, Ø1/2 x 5/8 LG	1

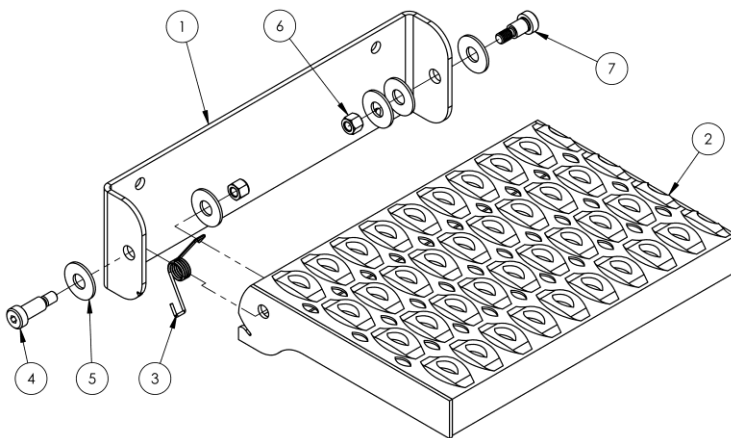

PRODUCT OVERVIEW

The manual covers two models: requiring user intervention to fold, and the spring-loaded product, which automatically returns to the vertical position when unloaded due to a torsion spring. Both are designed for industrial and commercial use, featuring a serrated steel surface for traction and a powder coat blue finish, with a uniform capacity of 350 lb. (159kg).

PARTS AND HARDWARE

A. Step Assembly (SA): A pre-assembled, manually-folded step unit; the product additionally includes a spring-biasing mechanism that automatically folds the step to its home position. NOTE: This manual also includes instructions for assembling your step, although you should receive an assembled unit. These instructions are provided to address the possibility that situations could occur which compel disassembling the step and then re-assembling it, e.g. to perform comprehensive maintenance.

B. Mounting Hardware (not included): Your building engineer should select fasteners appropriate for the mounting surface. The wall-mounting bracket of each series step has four (4) 3/8" mounting holes for receiving 5/16" mounting hardware.

TOOLS REQUIRED

- Drill and drill bits
- Flathead screwdriver (for thread cutting screws)
- Socket set (for tightening thread cutting screws)
- Measuring tape
- Pencil or marker

ASSEMBLING THE FOLDING STEP

For *unassembled* units, assemble the step as instructed in subpart I or II, as appropriate.

I. Manual Model:

Components:

- **Step weldment** (23-514-089), quantity 1
- **Mounting bracket** (23-016-084), quantity 1
- **Socket head shoulder bolts** (26347), quantity 2
- **Flat washers** (33012), quantity 4
- **Nylon insert lock nuts** (37024), quantity 2

Assembly Steps:

1. Lay the mounting bracket (23-016-084) on a flat surface.
2. Align the step weldment (23-514-089) with the bracket, ensuring the pivot holes match.
3. On one side of the mounting bracket, insert a socket head shoulder bolt (26347) through a flat washer (33012), and then through the hole in the bracket and step weldment. Slide another flat washer onto the free end of the bolt. Finally, loosely wind a nylon insert lock nut (37024) onto the bolt.
4. Repeat step 3 on the other side.
5. Tighten the lock nuts until secure, while ensuring that the step can pivot freely for manual folding.

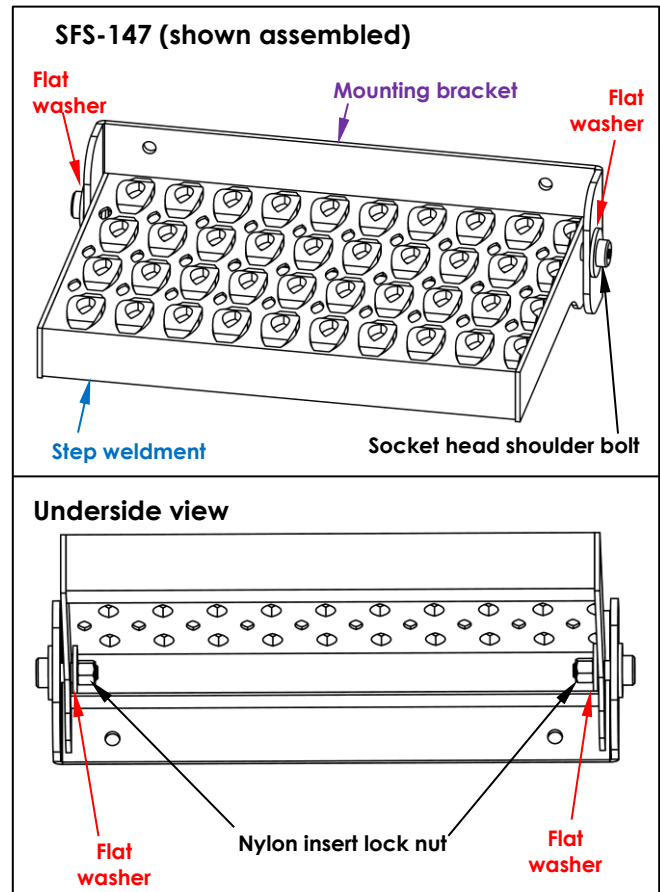





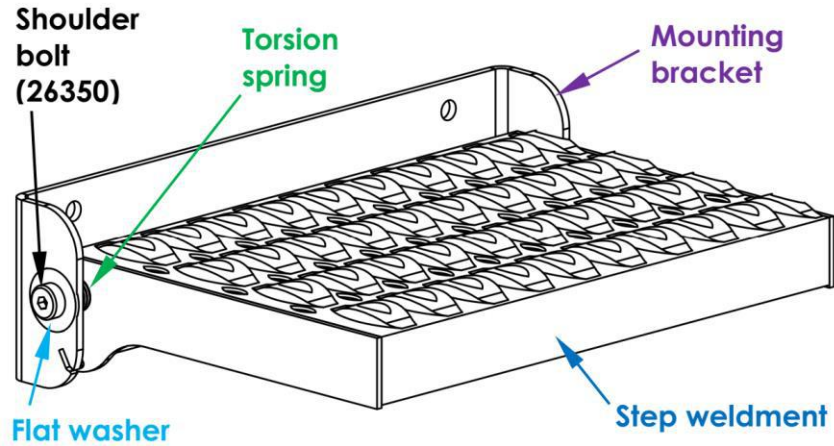

II. Spring-Loaded Model:

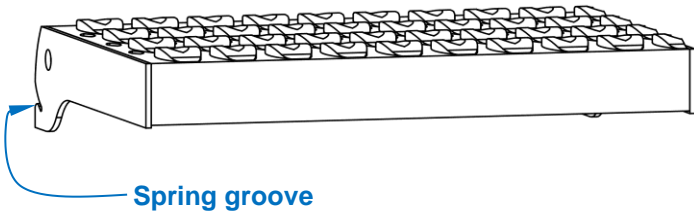
Fully Assembled

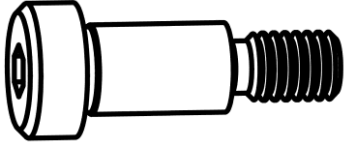

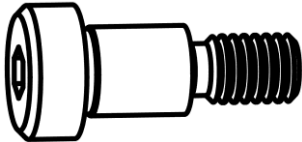
Components:

<ul style="list-style-type: none"> • Mounting bracket (23-016-110), quantity 1 	<ul style="list-style-type: none"> • Step weldment (23-514-114), quantity 1 
<ul style="list-style-type: none"> • Torsion spring (23-146-001), quantity 1 	<ul style="list-style-type: none"> • Large socket head shoulder bolt (26350), quantity 1 
<ul style="list-style-type: none"> • Flat washer (33086), quantity 5 	<ul style="list-style-type: none"> • Socket head shoulder bolt (26347), quantity 1 
<ul style="list-style-type: none"> • Lock nut (37024), quantity 2 	

Assembly Steps:

1. Place the **mounting bracket** (23-016-110) on a flat surface.
2. Insert a flat washer onto both the **large shoulder bolt** and the **shoulder bolt**. Install the bolts through the bolt holes in the mounting bracket as shown in the diagram.
3. Slide the **torsion spring** onto the free end of the large shoulder bolt. Seat an arm of the torsion spring into the spring groove of the mounting bracket.
4. Slide the left side of the **step weldment** onto the large shoulder bolt and the right side of the step onto the shoulder bolt. The bolts must be partially pulled out of the bolt holes to install the step.
5. Install 2 flat washers on the end of the shoulder bolt and 1 flat washer onto the large shoulder bolt.
6. Tighten lock nuts onto the ends of both shoulder bolts.
7. Move the step into Grab the free end of the **torsion spring** and carefully press it down until the arm seats into the **spring groove** of the step weldment.
8. Confirm that the spring automatically returns the step to the vertical position when not in use.

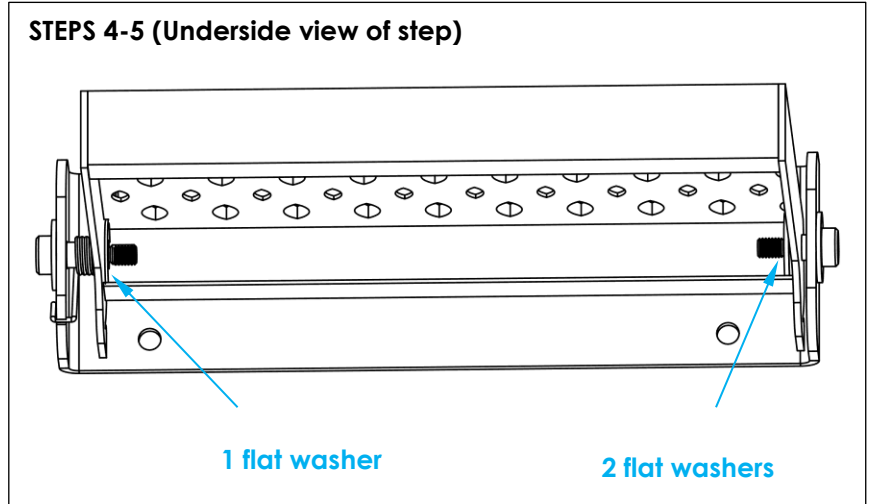
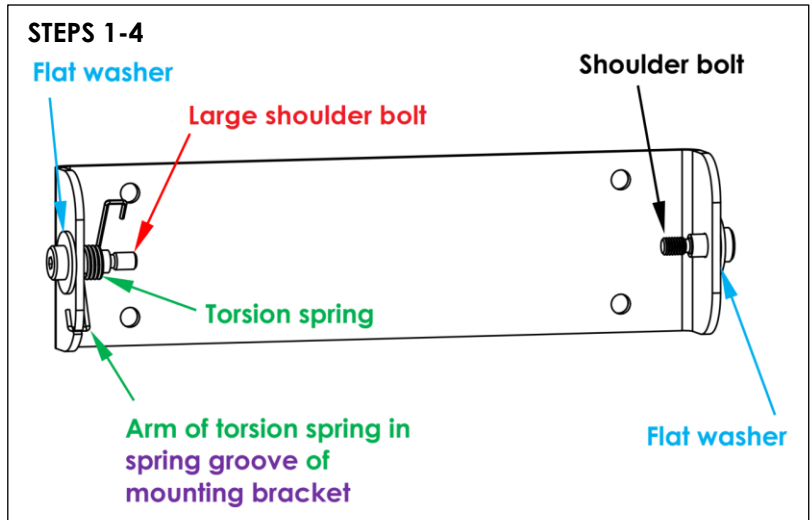

STEP 7: Attach second arm of torsion spring to spring groove of step.

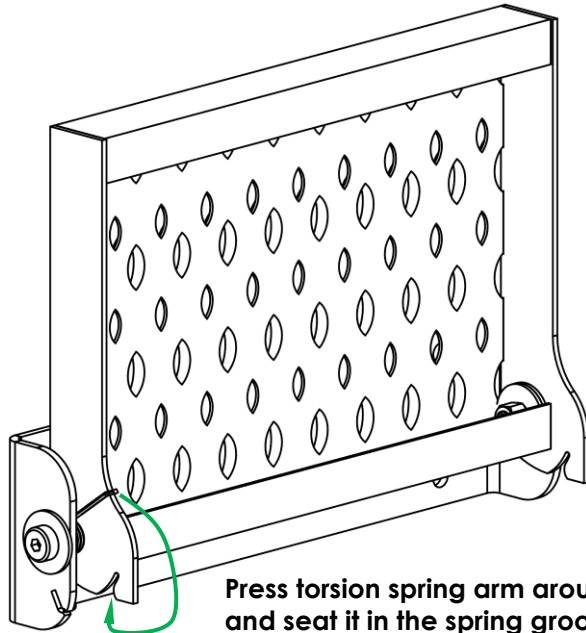

Press torsion spring arm around the end of the step and seat it in the spring groove.

INSTALLING THE FOLDING STEP

Note: Numbers in parentheses refer to part numbers from the respective model's [EXPLODED VIEW](#) and bill of materials on p. 4.

For both assembled and unassembled units, install the step by:

1. **Selecting an Installation Location:** Choose a flat, load-bearing surface capable of supporting the step (refer to your Specifications document) and a maximum capacity load (350 lb.). Ensure there is sufficient clearance for the step to fold up to a vertical position.
2. **Preparing the Mounting Surface:** The mounting bracket has pre-drilled mounting holes with different diameters:
 - Four (4) 3/8" diameter holes.
 - Four (4) 7/16" diameter holes.
 - Mark the locations of the mounting holes on the installation surface.
 - Drill holes into the mounting surface as required for your selected fasteners e.g., concrete anchors for concrete, lag screws for wood).
3. **Attaching the Mounting Bracket to the Surface:** Align the mounting bracket with the drilled holes, ensuring correct orientation for the step to fold upwards when not in use. Secure the bracket using fasteners (not included) selected for the job. The installer must select fasteners suitable for the installation surface to ensure stability and safety under load.
4. **Testing the Step:**
 - Manually rotate the step from the horizontal (USE) position and back to the vertical (HOME) position. The step should rotate smoothly and should be stable in both positions.
 - Press on the platform to lower it to the USE position; then release the step. Confirm that the step automatically returns to the HOME position.
 - **Verifying solid attachment:** Standing on the step must not cause the anchoring fasteners to loosen.
 - Check for any loose components and tighten as necessary to ensure safety and functionality.

RECORD OF SATISFACTORY CONDITION

Before placing the folding step into service, conduct a thorough *initial inspection* to establish a baseline record of its condition. This record serves as a reference for future inspections and maintenance, enabling users to identify subsequent damage, wear, or abnormalities that may develop over time. Follow these steps to create the record:

1. **Initial Inspection:** Examine the entire unit for any visible defects, including dents, cracks, compromised welds, corrosion, or deformations in the step weldment or mounting bracket. Confirm that all components are intact and free from shipping damage.
2. **Function Check:** Test the spring-biasing mechanism by pressing the step down. The step should automatically return to the HOME position.
3. **Label Verification:** Ensure all labels are present, legible, and securely attached as shown in the [LABELING DIAGRAM](#) on p. 9. Note any missing or damaged labels for immediate replacement.
4. **Documentation:** Before putting the folding step into regular service, record its appearance and operation. Take photographs of all components. Take close range photos of the pivot points, the spring and all fasteners including the anchoring hardware. Take a short video that records the folding process. Collect all photos, writings, and videos in a file. This file is a record of the folding step in satisfactory condition.

INSPECTING AND MAINTAINING THE FOLDING STEP

Compare inspection results to your [RECORD OF SATISFACTORY CONDITION](#). Do not continue to use the folding step unless all components are in [SATISFACTORY CONDITION](#). Cosmetic changes, like damaged paint/powder coat do not constitute changes from satisfactory condition. However, touchup paint should be applied to all affected areas as soon as damage occurs. Don't guess! If you are uncertain whether your product is safe to use, contact the [TECHNICAL SERVICE & PARTS DEPARTMENT](#) to discuss your concerns. If replacement parts are needed, contact the [TECHNICAL SERVICE & PARTS DEPARTMENT](#) to order replacement parts. Contact information is provided below as well as on the cover page of this manual.

1. Beginning of each day of use:

- Spring : Make sure that the spring is functioning correctly, i.e. firmly folds the folding step and holds it in the home position. If the spring is missing or damaged, then the lock will not operate.
- Anchoring/mounting hardware: Examine the fasteners that attach the step to the mounting surface. All fasteners must be in place and tightly attached to the mounting bracket and the mounting surface. The material of the mounting surface around the mounting fasteners must be sound and undamaged.

2. Monthly inspections:

- Step weldment: Examine the step for rust, breaks, cracks, and other forms of damage. Do not continue to use the step if it is structurally compromised.
- Fasteners: Check shoulder bolts, spring, lock nuts, and washers periodically for tightness. Tighten any loose connection. Make sure that the material around the shoulder bolts is sound. If a fastener cannot be tightened, replace it. Any time a lock nut is removed, *it must be replaced* with a new lock nut.
- Anchoring hardware: Verify that all anchoring fasteners are solidly attached to the step mounting surface. The mounting bracket should not be able to move. Tighten fasteners as necessary. If an anchor connection cannot be
- Step pivot points: If the movement becomes stiff, apply a light lubricant to the pivot points.
- Surfaces: Clean debris, rust, or corrosion from all surfaces. Apply touchup paint wherever the finish is damaged.

LABELING DIAGRAM

Label content and location are subject to change, and therefore, your product might not be labeled exactly as shown in the diagram below. If the labels applied to your unit differ from those shown in the diagram, contact [TECHNICAL SERVICE](#) and report the inconsistency. Thoroughly photograph the unit when you first receive it as discussed in the [RECORD OF SATISFACTORY CONDITION](#) section. Make sure that your *RECORD* includes at least 1 photograph of each label. Replace all labels that are, or later become, damaged, missing, or not easily readable (e.g. faded).

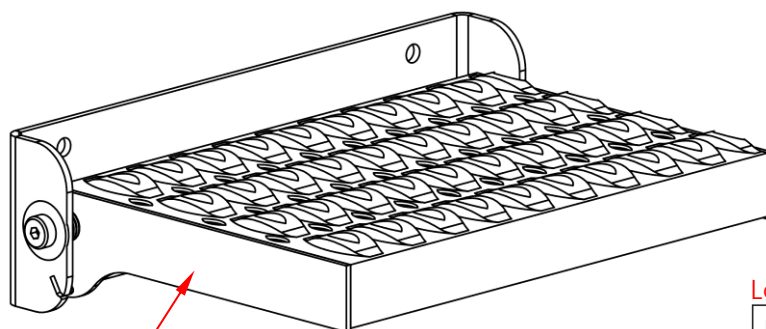

1153

Label 1153: Data label

MODEL / MODÉLO / MODÈLE _____
WEIGHT / PESO / MASS _____
CAPACITY / CAPACIDAD / CAPACITÉ _____
SERIAL / SERIE / SÉRIE _____
UNITS: 2.2 lb. = 1kg 1" (or 1in.) = 2.54cm
1153

LIMITED WARRANTY

We warrant this product to be free of defects in material and workmanship during the warranty period. Our warranty obligation is to provide a replacement for a defective, original part covered by the warranty after we receive a proper request from the Warrantee (you) for warranty service.

Who may request service?

Only a warrantee may request service. You are a warrantee if you purchased the product from us or from an authorized distributor AND we have been fully paid.

Definition of "original part"?

An original part is a part used to make the product as shipped to the Warrantee.

What is covered under the warranty?

The warranty covers defects in the following original, dynamic parts: motors, hydraulic pumps, electronic controllers, switches, and cylinders. It also covers defects in original parts that wear under normal usage conditions ("wearing parts"), such as bearings, hoses, wheels, seals, brushes, and batteries.

How long is the warranty period?

The warranty period for original dynamic components is 30 days. For wearing parts, the warranty period is 30 days. Both warranty periods begin on the date we ship the product to the Warrantee. If the product was purchased from an authorized distributor, the periods begin when the distributor ships the product. We may, at its sole discretion, extend a warranty period for products shipped from authorized distributors by up to 30 days to account for shipping time.

If a defective part is covered by the warranty, what will we do to correct the problem?

We will provide an appropriate replacement for any covered part. An authorized representative of we will contact you to discuss your claim.

What is not covered by the warranty?

The Warrantee (you) are responsible for paying labor costs and freight costs to return the product to us for warranty service.

Events that automatically void the Limited Warranty.

- Misuse;
- Negligent assembly, installation, operation or repair;
- Installation/use in corrosive environments;
- Inadequate or improper maintenance;
- Damage sustained during shipping;
- Collisions or other accidents that damage the product;
- Unauthorized modifications: Do not modify the product IN ANY WAY without first receiving written authorization from us.

Do any other warranties apply to the product?

We make no other express warranties. All implied warranties are disclaimed to the extent allowed by law. Any implied warranty not disclaimed is limited in scope to the terms of this Limited Warranty. We make no warranty or representation that this product complies with any state or local design, performance, or safety code or standard. Noncompliance with any such code or standard is not a defect in material or workmanship.