

# Assembly Instructions

⚠ Before you throw the carton, please ensure that you have all the parts needed for the assembly.

⚠ **Hardware Note:**  
1. For each step please don't fully tighten all the screws at first, when they all align to the holes you can fully tighten them.

2. All the bolts should be assembled **vertically** to the holes.

⚠ **Spare parts** can be found in the hardware box if you do not have enough bolts for assembly.

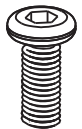

1pc

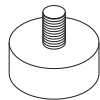

(foot caps)

2pcs

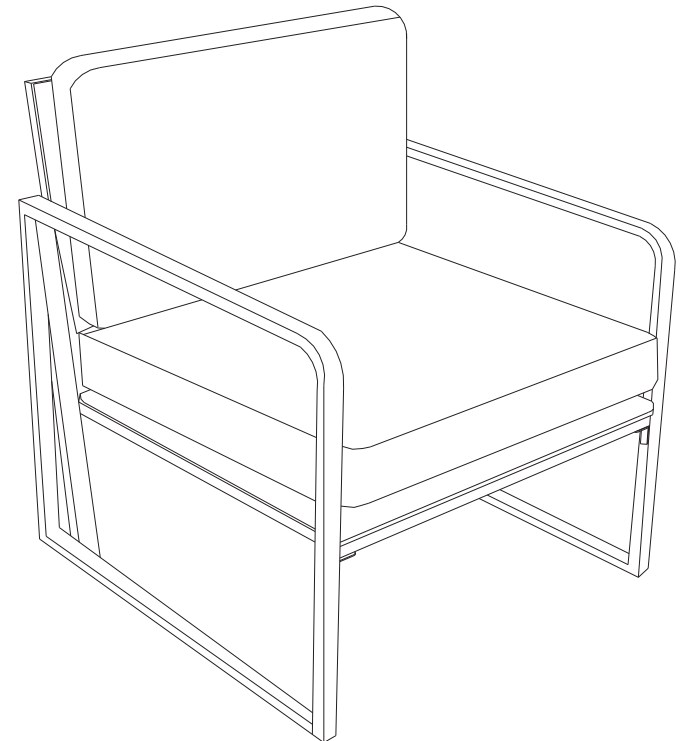

⚠ THIS INSTRUCTION BOOKLET CONTAINS IMPORTANT SAFETY INFORMATION. PLEASE READ AND KEEP FOR FUTURE REFERENCE.

# Assembly Instructions

## Parts and Hardware

Please check to make sure you have all parts and hardware before starting assembly process.

A

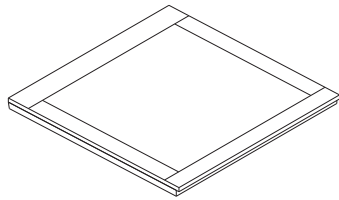

Seat Frame 1pc

B

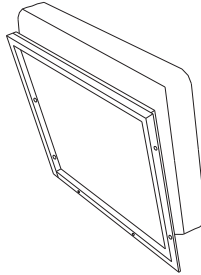

Back Cushion 1pc

C

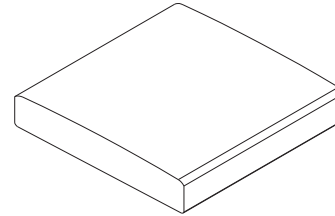

Seat Cushion 1pc

D

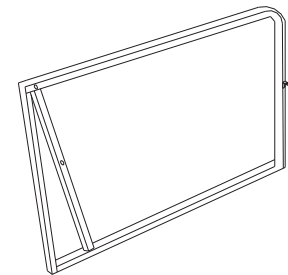

Right Arm 1pc

E

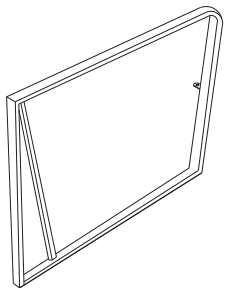

Left Arm 1pc

1

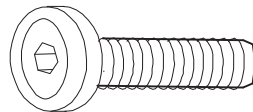

Long bolts 6pcs

2

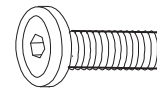

Short bolts 2pcs

3



Allen Wrench 1pc

# Assembly Instructions

## Assembly Instructions

Step 1: Assemble back to arms (see below diagram 1). Half tighten the bolts until they are align to the holes **do not fully tighten** them.

diagram 1

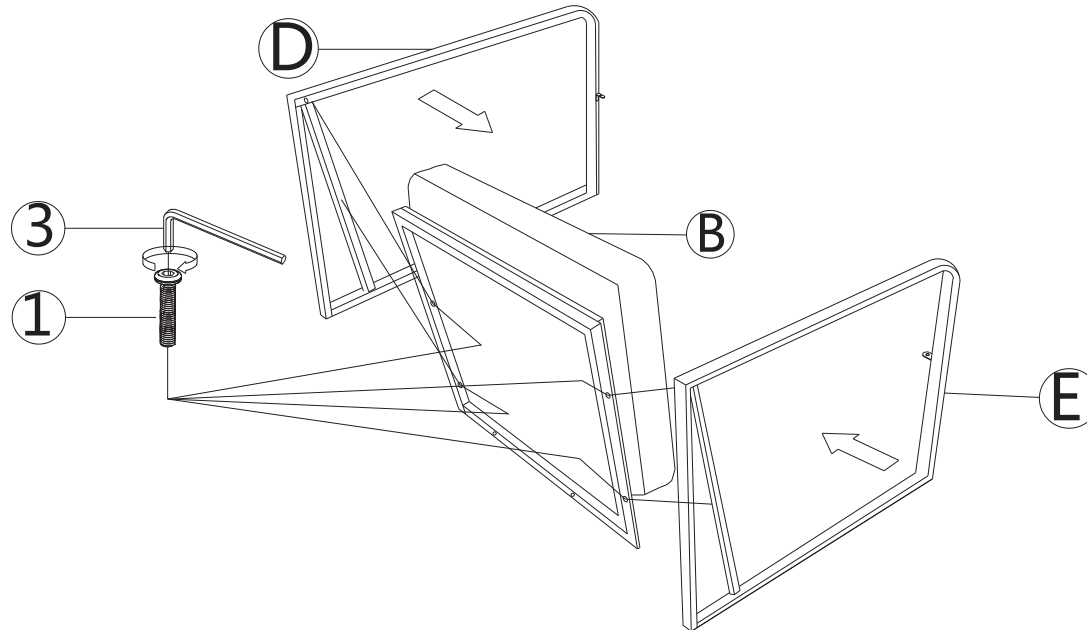

Step 2: Assemble seat frame to back. Half tighten the bolts until they are align to the holes. **do not fully tighten** them.

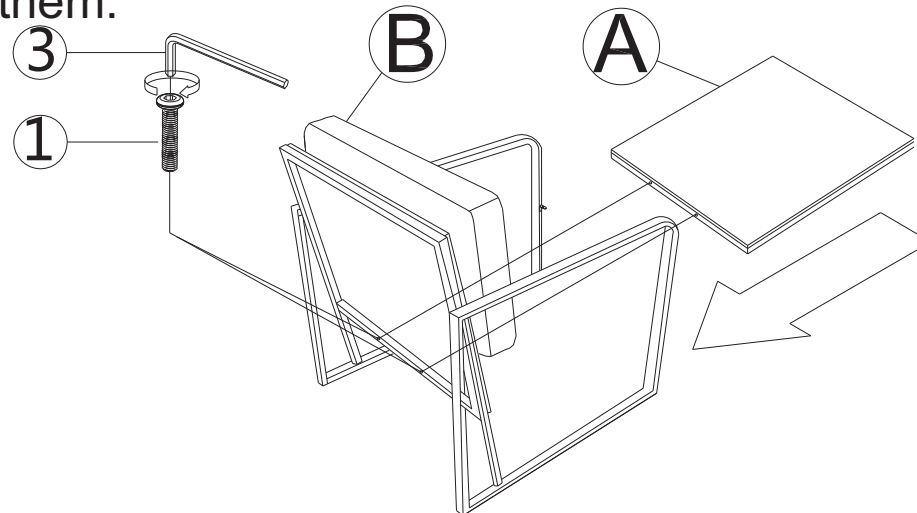

# Assembly Instructions

## Assembly Instructions

Step 4: Assemble seat frame to arms using short bolts ②, half tighten the bolts until they are align to the holes then fully tighten them (include step 1 & 2) by the short side of wrench.

