

# 2FB PANEL BED FRAME

affurnishings.com

## TWIN XL

### ASSEMBLY INSTRUCTIONS

Before assembling your bed frame, please read through these instructions carefully and familiarize yourself with the different parts.

**ATTENTION!** If you receive a damaged or defective item, please contact affurnishings.



#### PARTS LIST

- ① LEFT LEG 2 PCS
- ② RIGHT LEG 2 PCS
- ③ TOP/BOTTOM RAIL 4 PCS
- ④ FB PANEL 2 PCS
- ⑤ SIDE RAIL 2 PCS
- ⑥ SLAT KIT 2 SET

#### HARDWARE

- ① JCB M6 X 80mm (3 1/8") - 16 pcs  
Spare - 1 pc
- ② Barrel nut - 16 pcs
- ③ Wood screw (1 1/4") - 12 pcs  
Spare - 1 pc
- ④ Wood button - 16 pcs  
Spare - 1 pc
- ⑤ Allen wrench M4 - 1pc  
Spare - 1pc

NOTE: WE INCLUDE SPARE HARDWARE IN CASE DAMAGE OCCURS DURING ASSEMBLY.

#### Step 1

Attach right leg (2) to top/bottom rail (3), using JCB (A) and barrel nut (B). Tighten with the Allen wrench (E).

#### Step 2

Guide the FB panel (4) in carefully so that it won't jump out of its grooves. Be sure it fits fully into its groove at the leg before fitting the left leg (1).

#### Step 3

Attach left leg (1) to the footboard assemblies as shown below. Using JCB (A) and barrel nut (B). Tighten with allen wrench (E). Repeat the other.

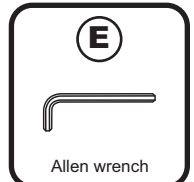
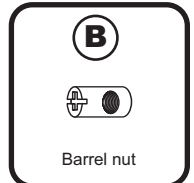
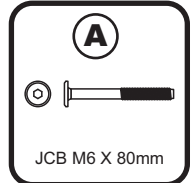
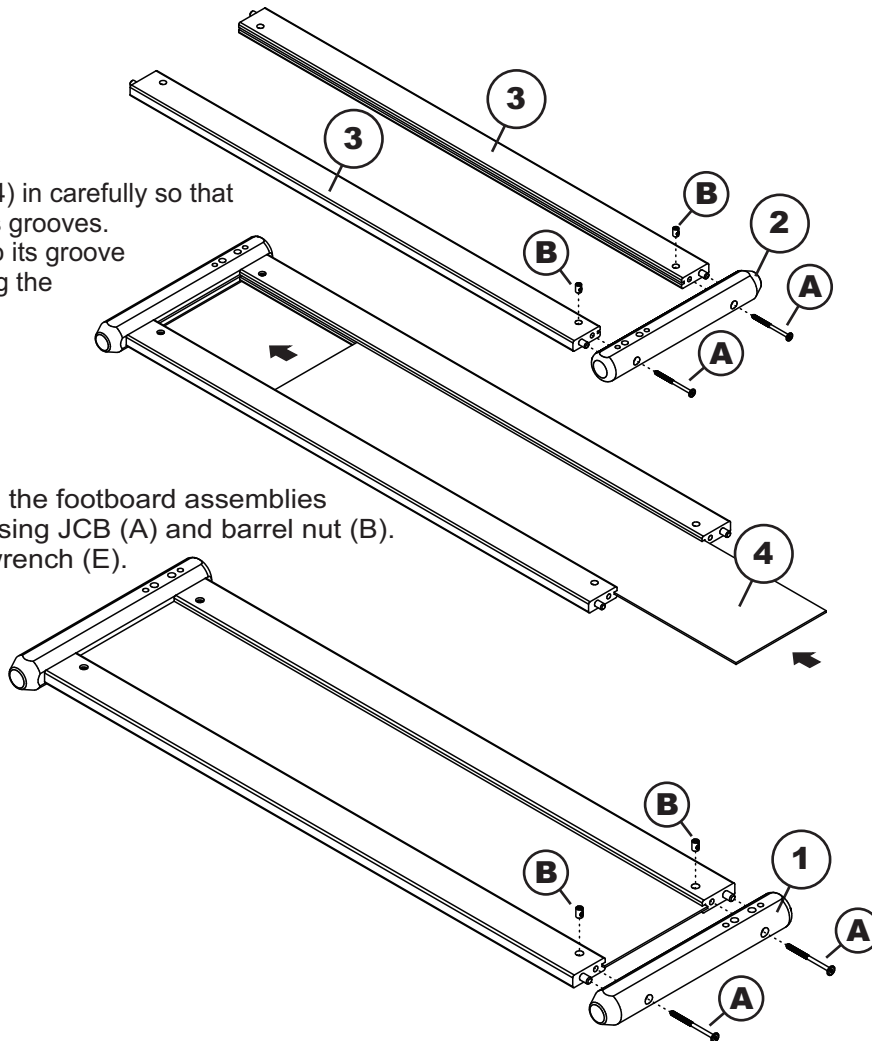

# TWIN XL

## Step 4

Attach side rails (5) to the headboard / footboard as shown below. Using JCB (A) and barrel nut (B) tighten with Allen wrench (E).

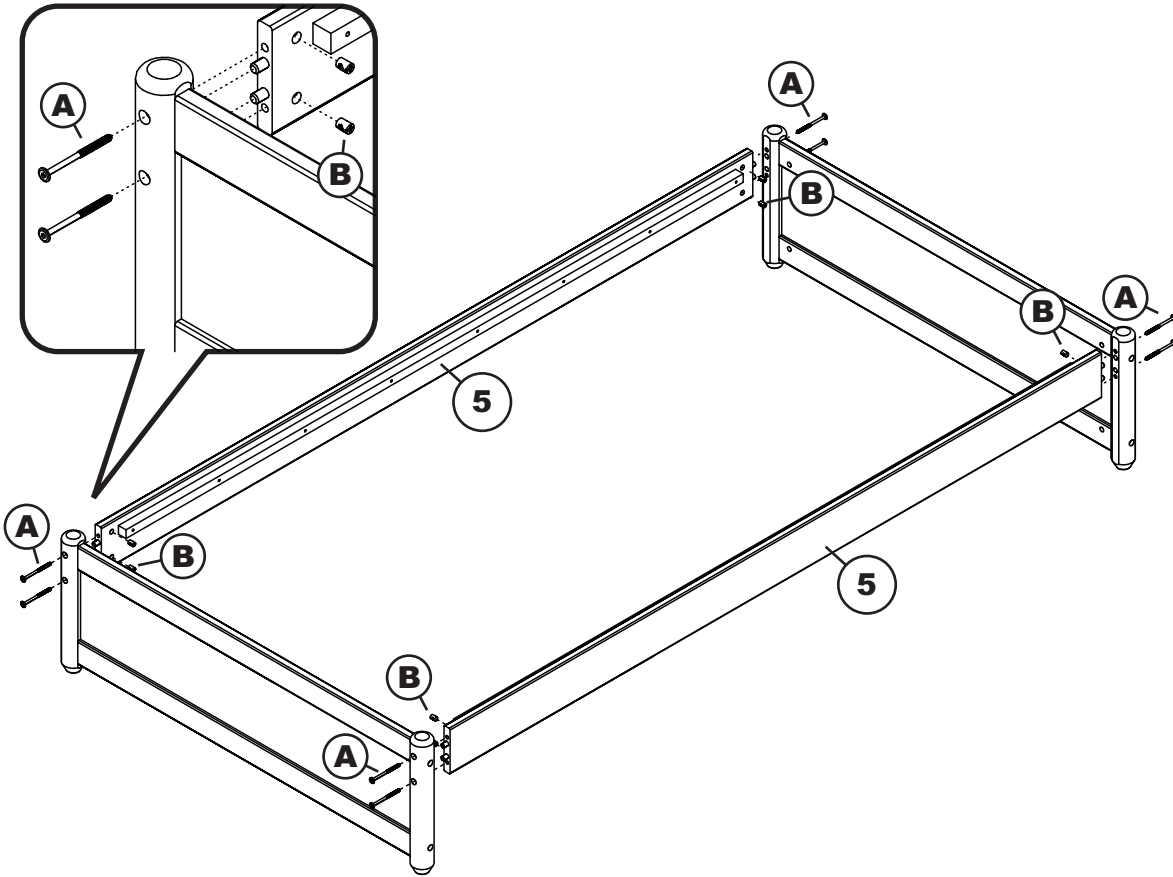

Adult assembly

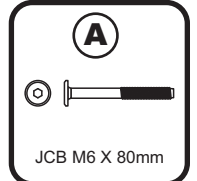

JCB M6 X 80mm

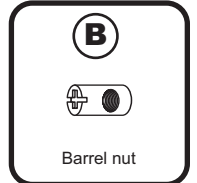

Barrel nut



Wood screw 1 1/4"

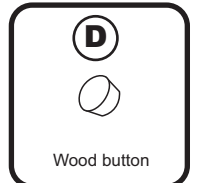

Wood button

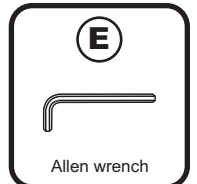

Allen wrench

## Step 5

Attach slat kit (6) onto the bed. Using wood screw (C) tighten with Phillips head screwdriver. (Customer supplied)  
Lastly, cover holes with wood button (D).

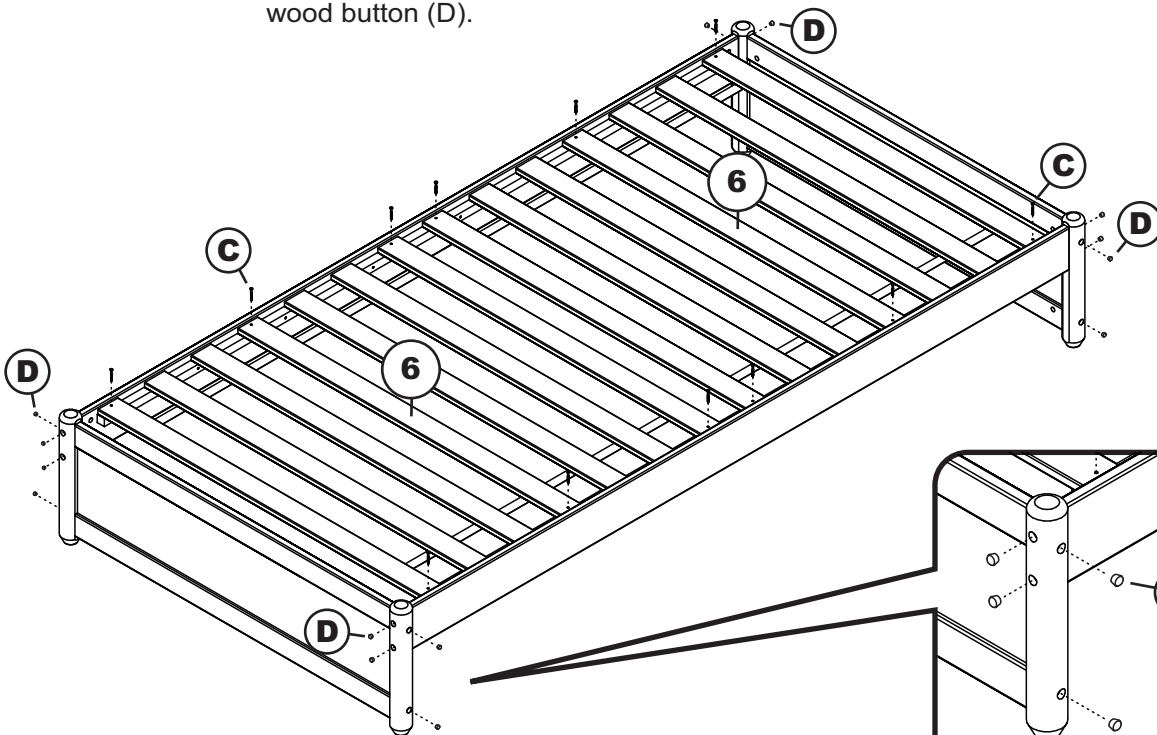

### Congratulations!

Your bed is now ready for use.

We recommend that you periodically recheck that all screws are tight to ensure lasting safety.

# BED DRAWER

afifurnishings.com

## ASSEMBLY INSTRUCTIONS

Before assembling your bed drawer, please read through these instructions carefully, familiarize yourself with the different parts.

**ATTENTION!** If you receive a damaged or defective item, please contact afifurnishings.

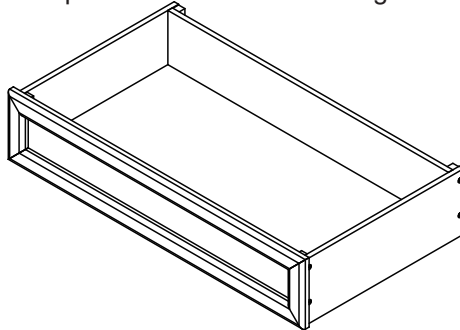
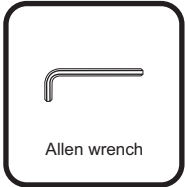

**NOTE: WE INCLUDE SPARE HARDWARE IN CASE DAMAGE OCCURS DURING ASSEMBLY.**

### HARDWARE

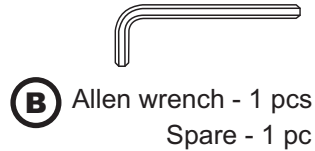
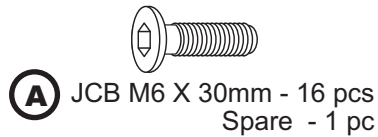

### PARTS LIST

<b>01</b>	<b>HARDWARE</b>	<b>1 BOX</b>
<b>02</b>	<b>DRAWER FACE</b>	<b>2 PCS</b>
<b>03</b>	<b>DRAWER SIDE</b>	<b>4 PCS</b>
<b>04</b>	<b>DRAWER BACK</b>	<b>2 PCS</b>
<b>05</b>	<b>DRAWER BOTTOM</b>	<b>2 PCS</b>

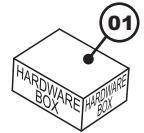
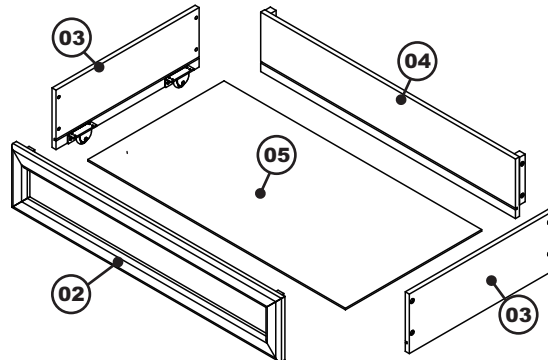

### Step 1

Lay the drawer face (02) on smooth, flat surface so the drawer bottom (05) groove is facing upwards. Attach the drawer sides (03) to drawer face (02) using JCB M6 X 30mm (A). Align groove inside drawer side with groove in drawer face. Tighten with Allen wrench (B).

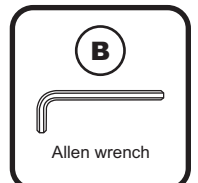
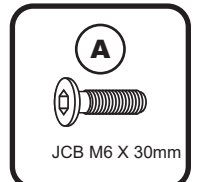
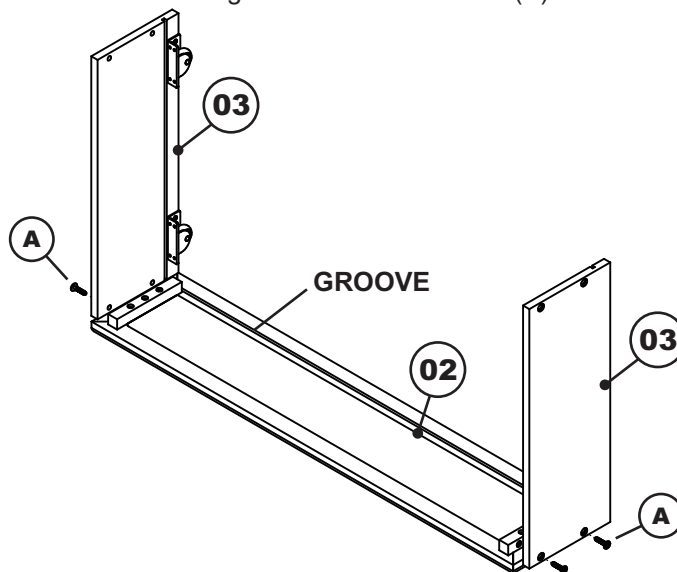

## Step 2

Guide the drawer bottom (05) in carefully so that it won't jump out of its grooves. Be sure it fits fully into its groove at the bottom (in the drawer face) before fitting the drawer back.

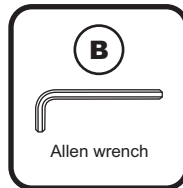
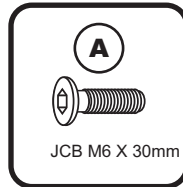
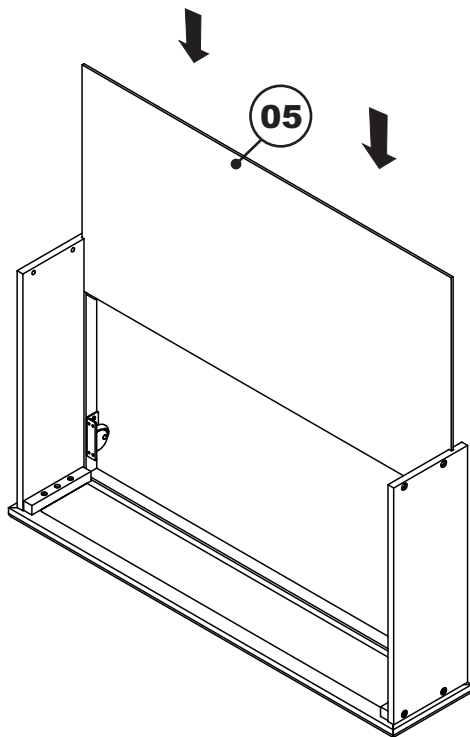

## Step 3

Attach drawer back (04) to bed drawer assembly as shown. Use JCB M6 X 30mm (A). Tighten with Allen wrench (B).

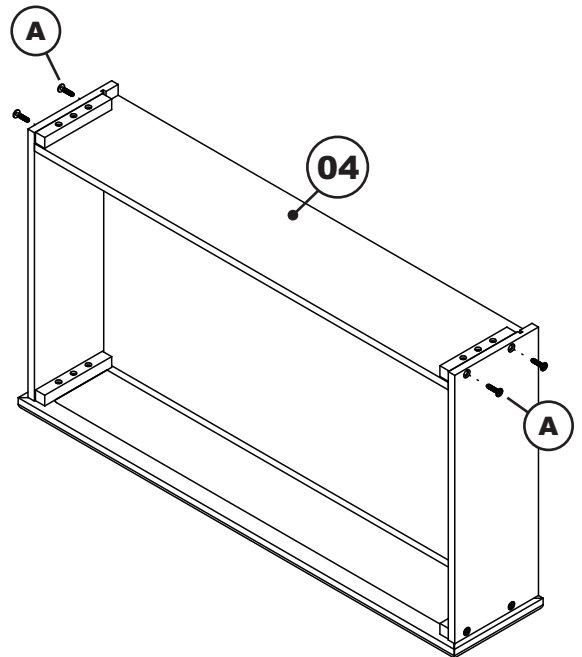

## Step 4

Lastly, insert bed drawer to the bed as shown below.

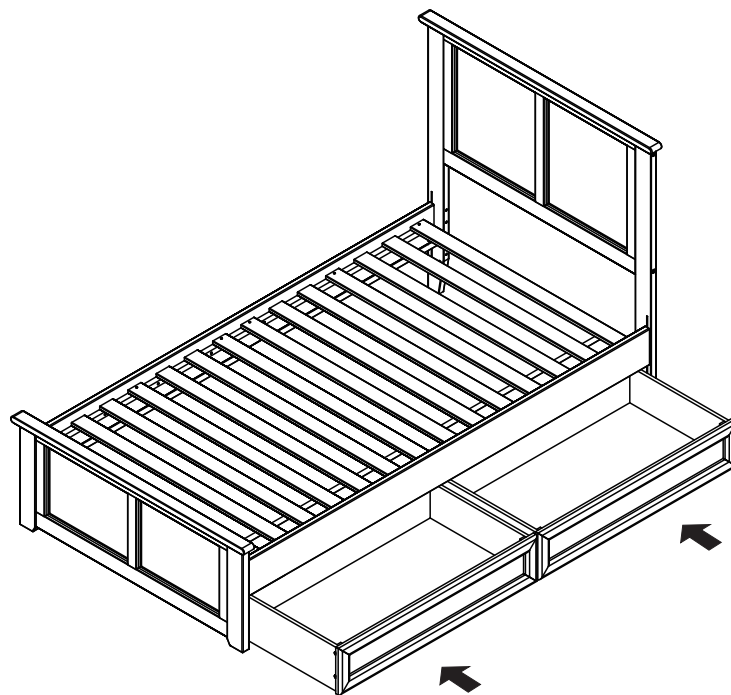

**Congratulations!**

Your bed drawer is now ready for use.  
We recommend that you periodically recheck that all screws are tight to ensure lasting safety.