

CHEST

ASSEMBLY INSTRUCTIONS



ASSEMBLY INSTRUCTIONS

ASSEMBLY TIPS:

1. Remove hardware from box and sort by size
2. Please check to see that all hardware and parts are present prior to start of assembly.
3. Please follow attached instruction in the same sequence as numbered to assure fast & easy assembly.



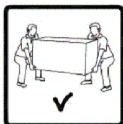

Warning!

1. Don't attempt to repair or modify parts that are broken or defective. Please contact the store immediately.
2. This product is for home use only and not intended for commercial establishment.





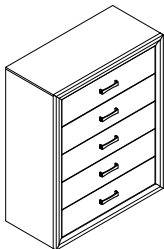

ASSEMBLY TIME 10 MINUTES

PARTS IDENTIFICATION

A		CHEST	1PC
B		LEG	4PCS

HARDWARE IDENTIFICATION

1		WOOD DOWEL	4PCS
2		BOLT	4PCS
3		LOCK WASHER	4PCS
4		FLAT WASHER	4PCS
5		ALLEN WRENCH	1PC

NOTE : PHILLIPS HEAD SCREW DRIVER IS REQUIRED IN THE ASSEMBLY PROCESS; HOWEVER MANUFACTURER DOES NOT PROVIDE THIS ITEM.

STEP 1

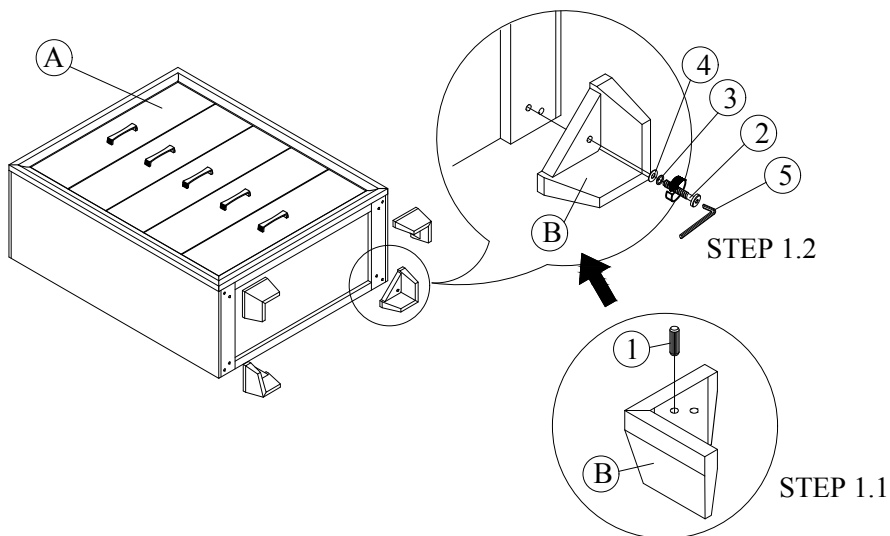

COMPLETE

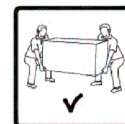
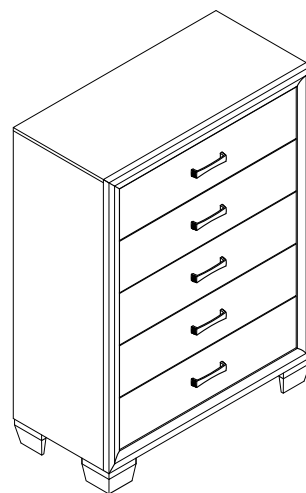

ANTI - TIPPING KIT

PARTS IDENTIFICATION

A

CHEST

1PC

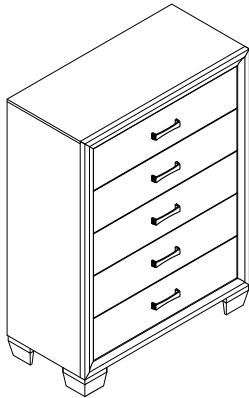

HARDWARE IDENTIFICATION

6



SHORT SCREW

1PC

7



LONG SCREW

1PC

8

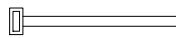

CABLE TIE

1PC

9



L BRACKET

2PCS

THIS TIP RESTRAINT MUST BE ATTACHED TO A WALL STUD USING LONG SCREW ENCLOSED.

STEP 1

Attach a bracket securely to the back top rail of the chest using short screw provided, through the smaller hole.

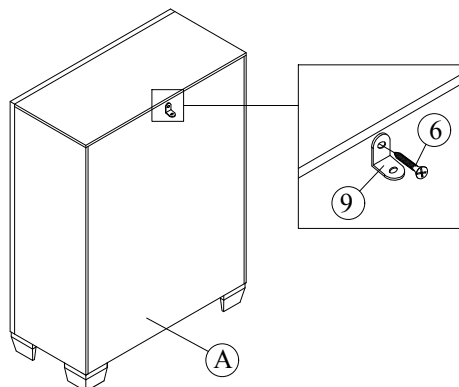

STEP 2

Locate the other bracket on the wall over a wall stud and two inches below the mounting bracket secured to the back of chest. Attached to the wall stud using the long screw provided, through the smaller hole.

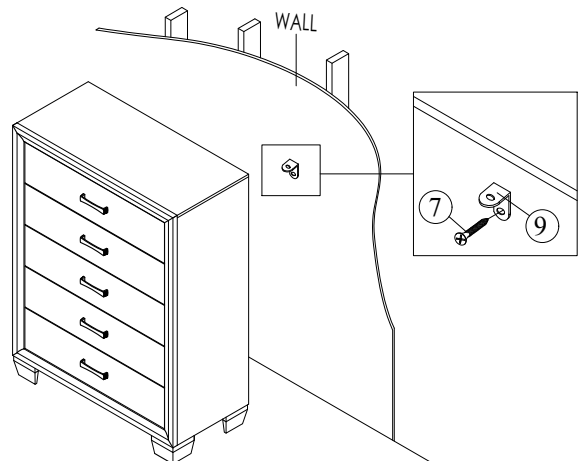

STEP 3

Place the chest into position so both mounting brackets are vertically in line. Lace the end of the restraint strap through the larger hole in each mounting bracket. Bring both ends together and slide the flat end through the locking end and draw it through until all slack is removed. Confirm that the strap is securely laced and locked.

